

(No Model.)

6 Sheets—Sheet 1.

T. CRANEY.
EVAPORATING PAN.

No. 525,486.

Patented Sept. 4, 1894.

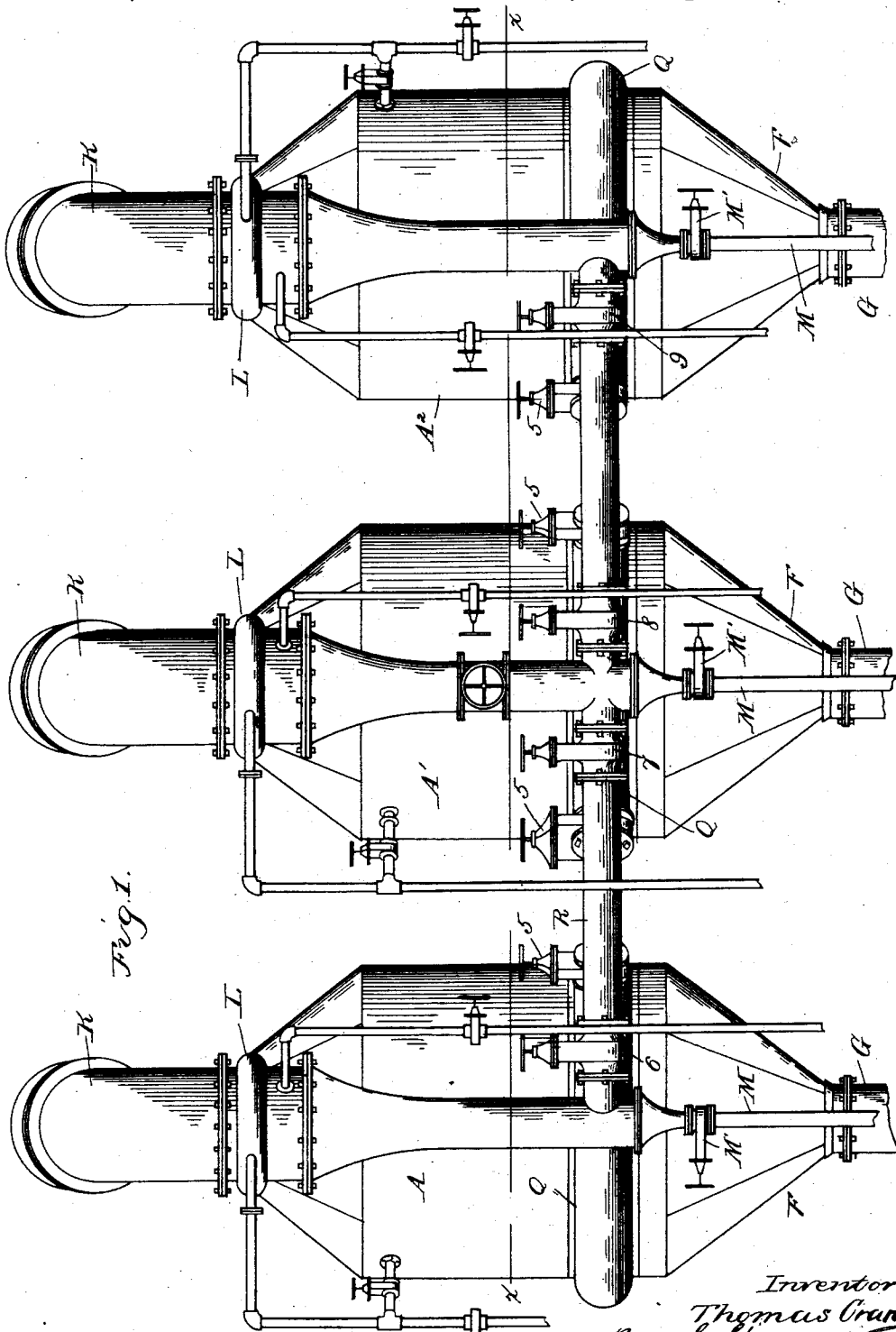

Fig. 1.

Witnesses
A. L. Koby
W. B. Dogherty

Inventor
Thomas Craney
By Tho. S. Spaquet
Attys.

T. CRANEY.
EVAPORATING PAN.

No. 525,486.

Patented Sept. 4, 1894.

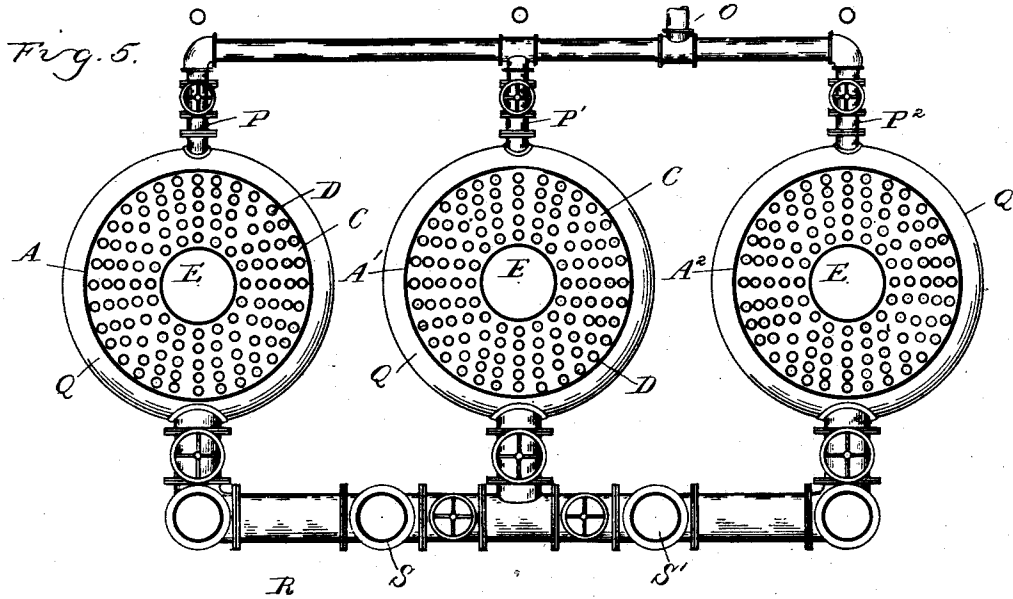
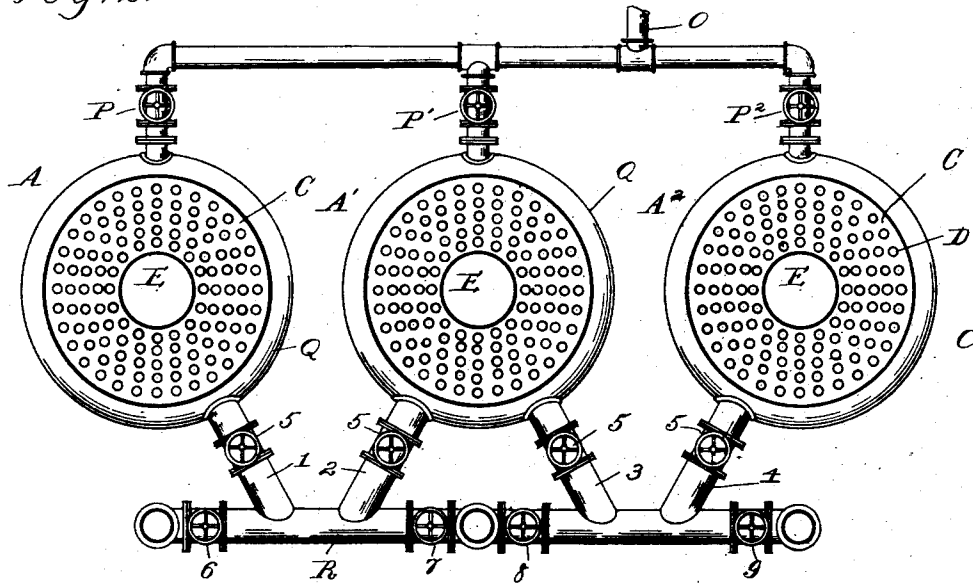

Fig. 2.



Witnesses
C. L. Shabby
M. D. Shabby

Inventor
Thomas Craney
 By *Wm. S. Sprague* Esq.
Atty.

(No Model.)

6 Sheets—Sheet 3.

T. CRANEY.
EVAPORATING PAN.

No. 525,486.

Patented Sept. 4, 1894.

Fig. 3.

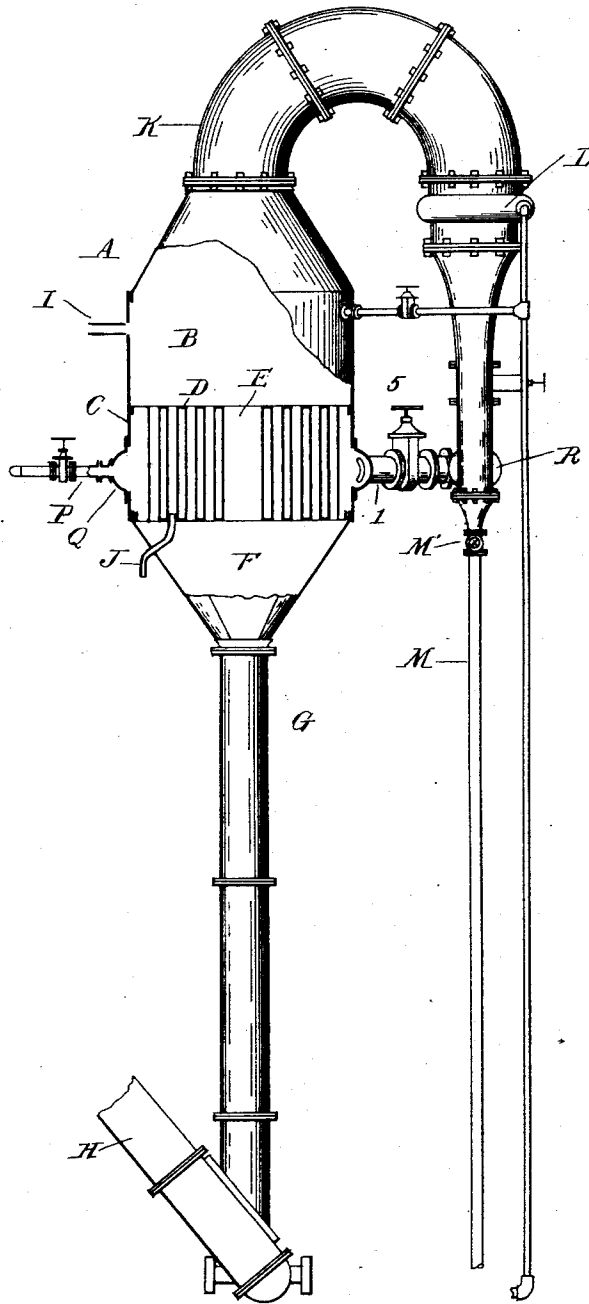

Witnesses
A. L. Stabby
M. D. DeGherty

Inventor
Thomas Craney
By *Wm. S. Sprague & Son*
Attys.

(No Model.)

6 Sheets—Sheet 4.

T. CRANEY.
EVAPORATING PAN.

No. 525,486.

Patented Sept. 4, 1894.

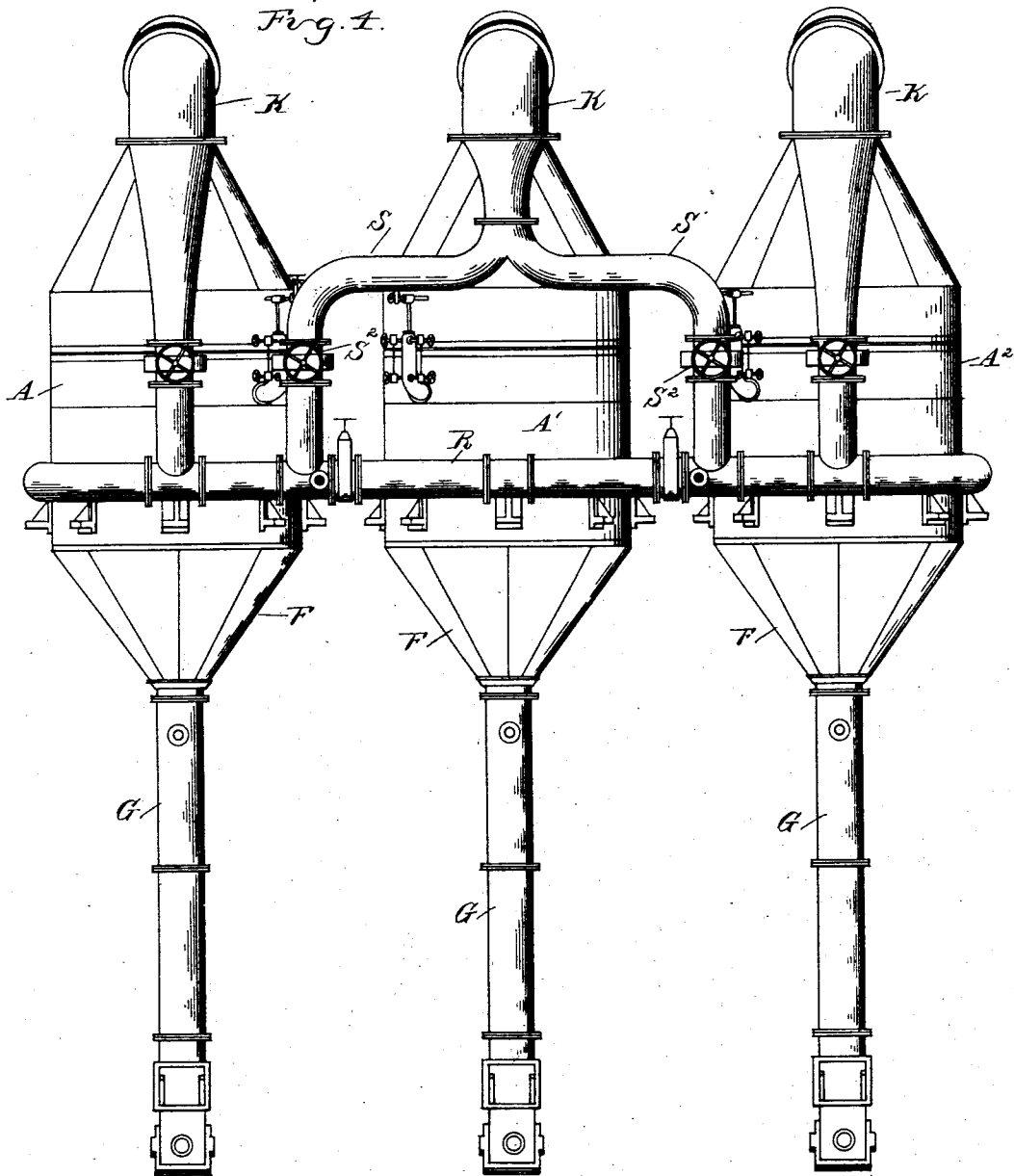

Witnesses
A. L. Hobby
H. B. Bogherty

Inventor
Thomas Craney
By *Thos. S. Spaguel*
Attys.

(No Model.)

6 Sheets—Sheet 5.

T. CRANEY.
EVAPORATING PAN.

No. 525,486.

Patented Sept. 4, 1894.

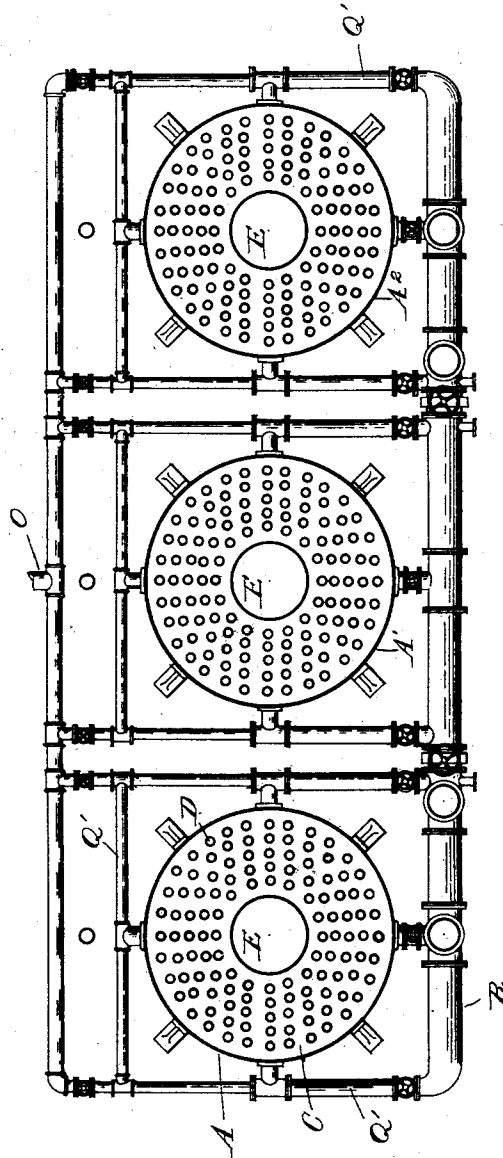

Fig. 6.

Witnesses
A. L. Hobby
Thos. Osogherly.

Inventor
Thomas Craney
By Mr. S. Spragell
Atty.

T. CRANEY.
EVAPORATING PAN.

No. 525,486.

Patented Sept. 4, 1894.

Fig. 7.

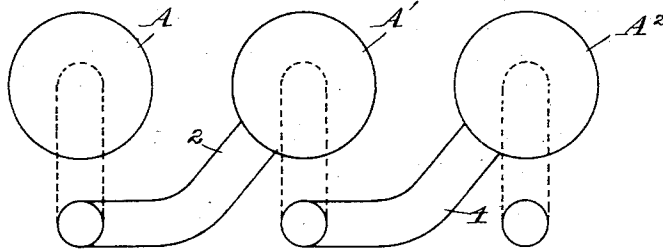

Fig. 8.

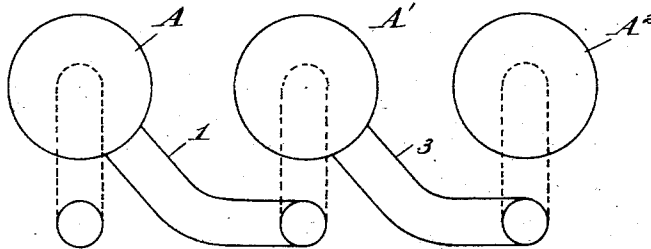

Fig. 9.

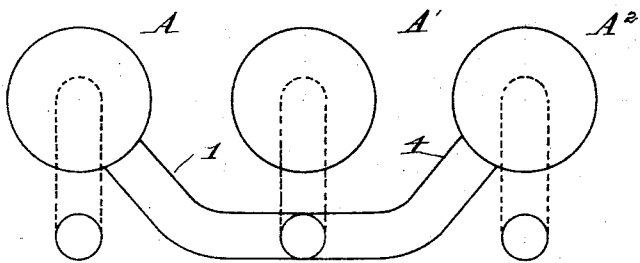
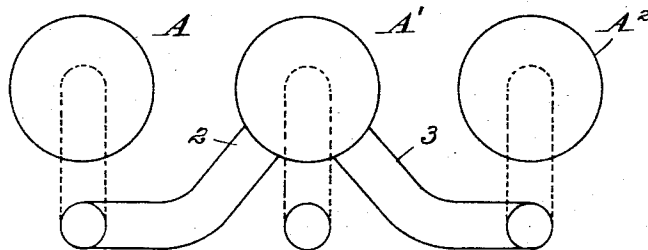

Fig. 10.



Witnesses
A. L. Hobbie
Th. P. O'Connell

Inventor
Thomas Craney
By Mr. S. Spaguet
Attys.

UNITED STATES PATENT OFFICE.

THOMAS CRANEY, OF BAY CITY, MICHIGAN.

EVAPORATING-PAN.

SPECIFICATION forming part of Letters Patent No. 525,486, dated September 4, 1894.

Application filed March 6, 1894. Serial No. 502,535. (No model.)

To all whom it may concern:

Be it known that I, THOMAS CRANEY, a citizen of the United States, residing at Bay City, in the county of Bay and State of Michigan, have invented certain new and useful Improvements in Evaporating Apparatus, of which the following is a specification, reference being had therein to the accompanying drawings.

The invention consists in the peculiar construction, arrangement and combination of a multiple of evaporating chambers or pans adapted for independent operation, with connections between the vapor discharge pipes and the steam heating chambers of the various pans, whereby the pans may be used independently or for a double or triple expansion as desired, all as more fully hereinafter described.

In the drawings, Figure 1 is a front elevation of my improved apparatus. Fig. 2 is a cross section on line *xx*. Fig. 3 is a side elevation partly in section. Fig. 4 is a front elevation of my apparatus showing a modified arrangement of the connections. Fig. 5 is a section similar to Fig. 2 through Fig. 4. Fig. 6 is a section similar to Fig. 5 showing a modification of the connecting pipes specifically referred to. Figs. 7, 8, 9 and 10 are diagram views specifically referred to.

The construction shown in Figs. 1 and 2 is the one I deem preferable and I shall therefore describe that first, the other constructions herein shown and modifications thereof may be employed without departing from the spirit of my invention.

In the manufacture of salt and in the use of evaporating pans in many other industries it frequently happens that it is desirable to change the temperature of the heating agent in some one of the pans of a series. It also frequently happens that one or more of the series may be desired to be cut out for cleaning or repairing without desiring to cut out the others of the series.

My invention contemplates such a connection between a series of evaporating pans or chambers as will enable me to obtain the above results not heretofore obtained with such apparatus.

A A' A² are similar casings, each having formed therein the evaporating chamber B

and the steam heating chamber C. Through the steam heating chamber is formed a series of circulating flues D and preferably a central, circulating pipe E, permitting a circulation of the fluid in the casing, so that the heavy portions and the crystals of salt, (if salt is being obtained) may fall to the bottom, while the hot water and vapor may arise into the evaporating chamber. At the lower end of the casing I form a settling chamber F having a settling leg G, at the lower end of which is a suitable carrier H for taking off the accumulated salt or other material to any desired point.

The evaporating chamber is provided with a suitable inlet pipe I for the brine, and the steam chamber is provided with a suitable exit pipe J for the water of condensation. From the top of each evaporating chamber is the vapor discharge pipe K leading to a suitable condenser L, and terminating in a discharge leg M, which is controlled by means of a valve M'.

O is a steam supply pipe and P P' and P² are valved branches therefrom leading into the steam chambers of the pans A A' A² respectively.

In order to properly distribute the steam at all points in the steam chamber I connect the steam pipe into an annular supply ring Q around the steam chamber, as shown in Fig. 2 and this construction I consider preferable, but I may connect it instead into a surrounding belt of pipes Q', as shown in Fig. 6, having a multiple of connections into the steam chamber, as shown therein, and effect the same satisfactory distribution.

The vapor discharge pipes I connect into a common connecting pipe R which is connected with the steam chamber in the pan A by the pipe 1, with the steam chamber of the pan A' by means of the pipes 2 and 3, and with the steam chamber of the pan A² by the pipe 4, each of these pipes being controlled by a suitable valve 5.

6, 7, 8 and 9 are valves in the connecting pipe R.

The parts being thus constructed their operation is as follows: If it is desired to supply steam from the steam pipe O to the pan A and then use the vapor arising from that pan to effect evaporation in the pan A' and

use the vapor from the pan A' to effect an evaporation in the pan A², the steam entering the ring Q around the pan A will be distributed through the steam chamber C therein, heating the brine and the vapor therefrom will rise and find exit through the discharge pipe K of this pan entering the end of the connecting pipe R. The valve 5 in the pipes 1 and 3 being closed and the valves 7 and 9 in the pipe R being closed, the valves 6 and 8 in the pipe R being open and the valves 5 in the pipes 2 and 4 being open, the vapor will pass from the discharge pipe K of the pan A into the steam chamber of the pan A' heating and vaporizing the fluid therein the vapor from which will pass from its discharge pipe K into the pipe R and from thence through the pipe 4 into the steam chamber of the pan A² from which pan the vapor will pass out through its discharge pipe K, the valve M' in which will be open and the condenser L will be in operation to create a vacuum. This circulation is shown in diagram in Fig. 7. In case it is desired to reverse this order and start with A², the circulation will be as shown in Fig. 8. In case it is desired to supply live steam to the central pan and use both of the end pans as vacuum pans, the circulation will be as shown in Fig. 9, and in case it is desired to supply the two end pans with live steam and use the middle one only for a vacuum pan the circulation will be as shown in Fig. 10. It will be obvious from these diagrams which of the valves shall be opened or closed for a given circuit.

It is evident that if the valves 5 in the pipes 1, 2, 3 and 4 and all of the valves in the pipe R are closed the steam supplied through

the branches P P' P² that all or any one of the pans may be operated separately.

Figs. 4 and 5 show a slightly modified arrangement of these connections. Instead of using the two connecting pipes 2 and 3 from the pipe R I have shown the vapor pipe K from the middle tank forked to form the two branch pipes S S' and supplied with valves S². With this construction I am enabled to effect the same results.

What I claim as my invention is—

1. In an evaporating apparatus, the combination of a series of evaporating pans each having a heating chamber and a valved discharge pipe, a trunk into which the discharge pipes lead, valved steam pipes for the heating chambers, pipes leading from the trunk into the heating chambers, and a series of valves in the respective pipes arranged to permit of the vapor from one pan being passed into the heating chamber of either of the other pans, substantially as described.

2. In an evaporating apparatus, the combination of a series of evaporating pans, each having a vapor heating chamber, a condenser for each, a discharge pipe from each condenser, a common trunk into which said discharge pipes connect, a valved pipe for each discharge pipe below the trunk, valved connections from the trunk to the heating chamber of each pan, valved steam supply pipes to each heating chamber, substantially as described.

In testimony whereof I affix my signature in presence of two witnesses.

THOMAS CRANEY.

Witnesses:

M. B. O'DOGHERTY,
O. F. BARTHEL.