



US 20040187548A1

(19) **United States**

(12) **Patent Application Publication** (10) **Pub. No.: US 2004/0187548 A1**

**Okada et al.** (43) **Pub. Date: Sep. 30, 2004**

(54) **METHOD AND APPARATUS FOR INCREMENTAL FORMING**

(30) **Foreign Application Priority Data**

Mar. 28, 2003 (JP) ..... 2003-089942

(76) Inventors: **Norihisa Okada**, Hikari-shi (JP); **Gen Ro**, Fujinomiya-shi (JP); **Yohji Suzuki**, Shizuoka-shi (JP); **Masatoshi Nara**, Fujinomiya-shi (JP)

**Publication Classification**

(51) **Int. Cl.<sup>7</sup>** ..... **B21D 31/00**

(52) **U.S. Cl.** ..... **72/379.2**

Correspondence Address:

**ANTONELLI, TERRY, STOUT & KRAUS, LLP**

**1300 NORTH SEVENTEENTH STREET SUITE 1800**

**ARLINGTON, VA 22209-9889 (US)**

(57) **ABSTRACT**

In forming a secondary form portion having a three-dimensional shape to a part of a primary form portion having a two-dimensional curved plane, a work **240** having a curved plane corresponding to the shape of the primary form portion is prepared, and only the secondary form portion is created by incremental forming.

(21) Appl. No.: **10/650,808**

(22) Filed: **Aug. 29, 2003**

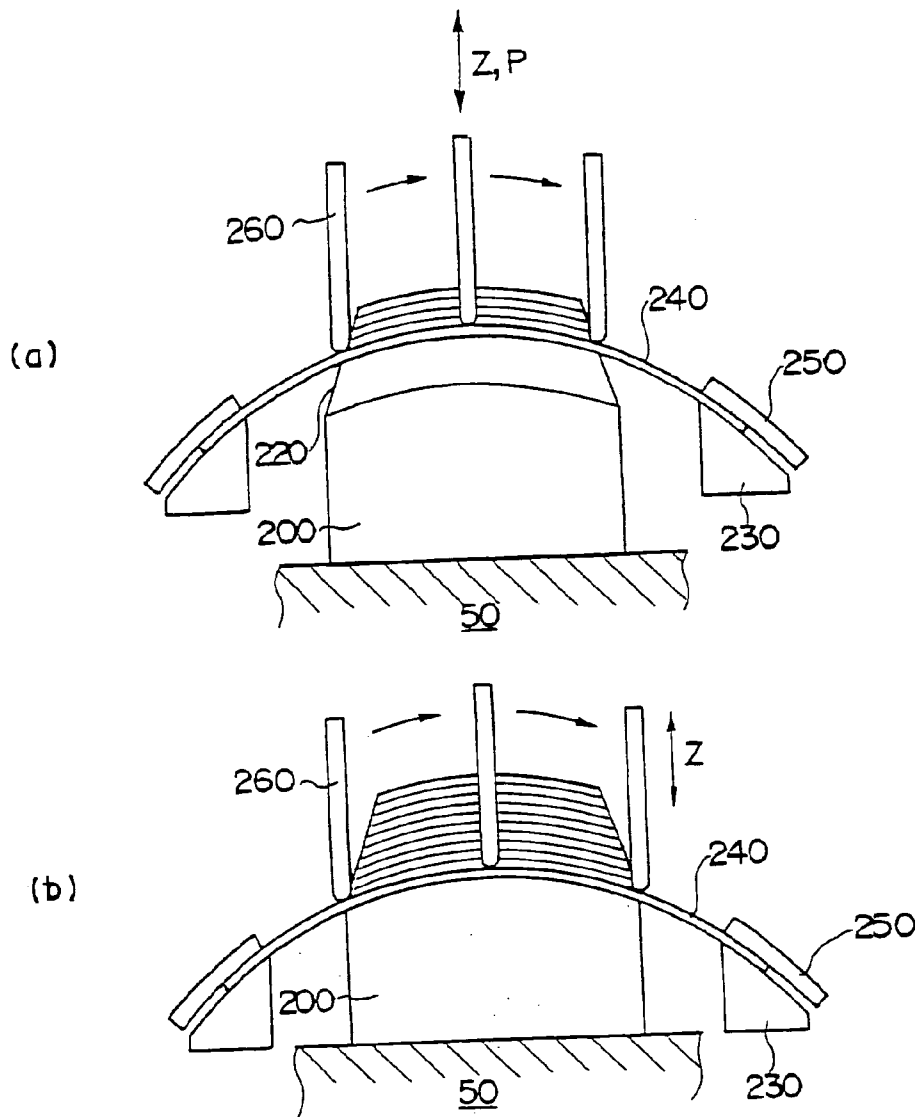

FIG. 1

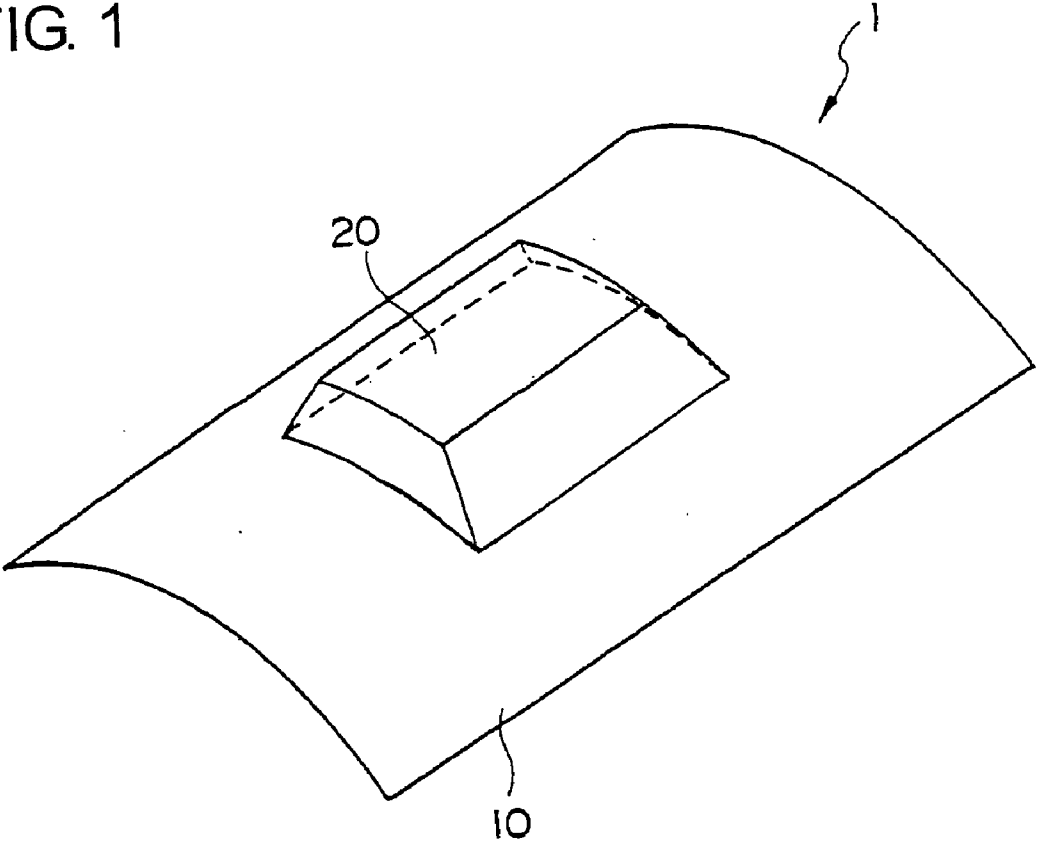

FIG. 2

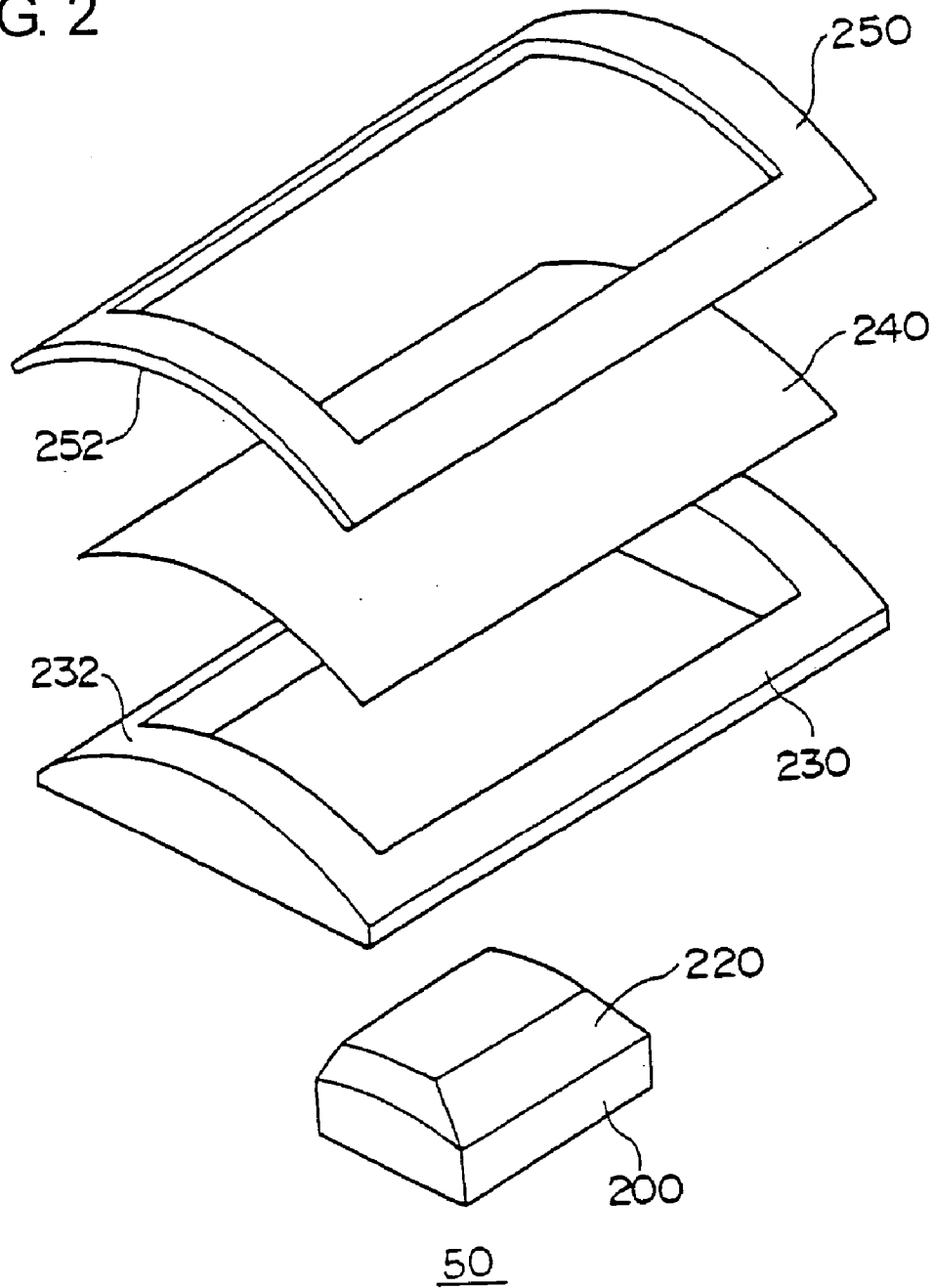

FIG. 3

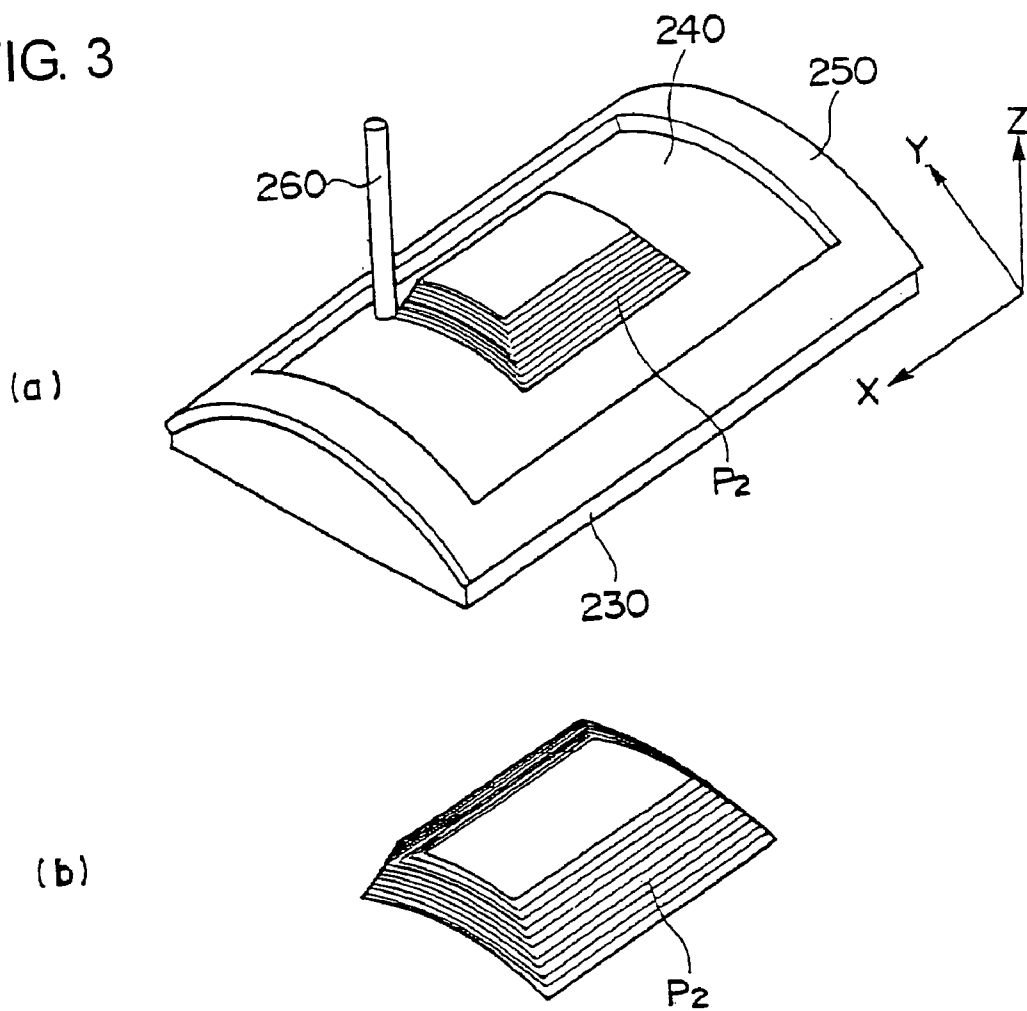



FIG. 5

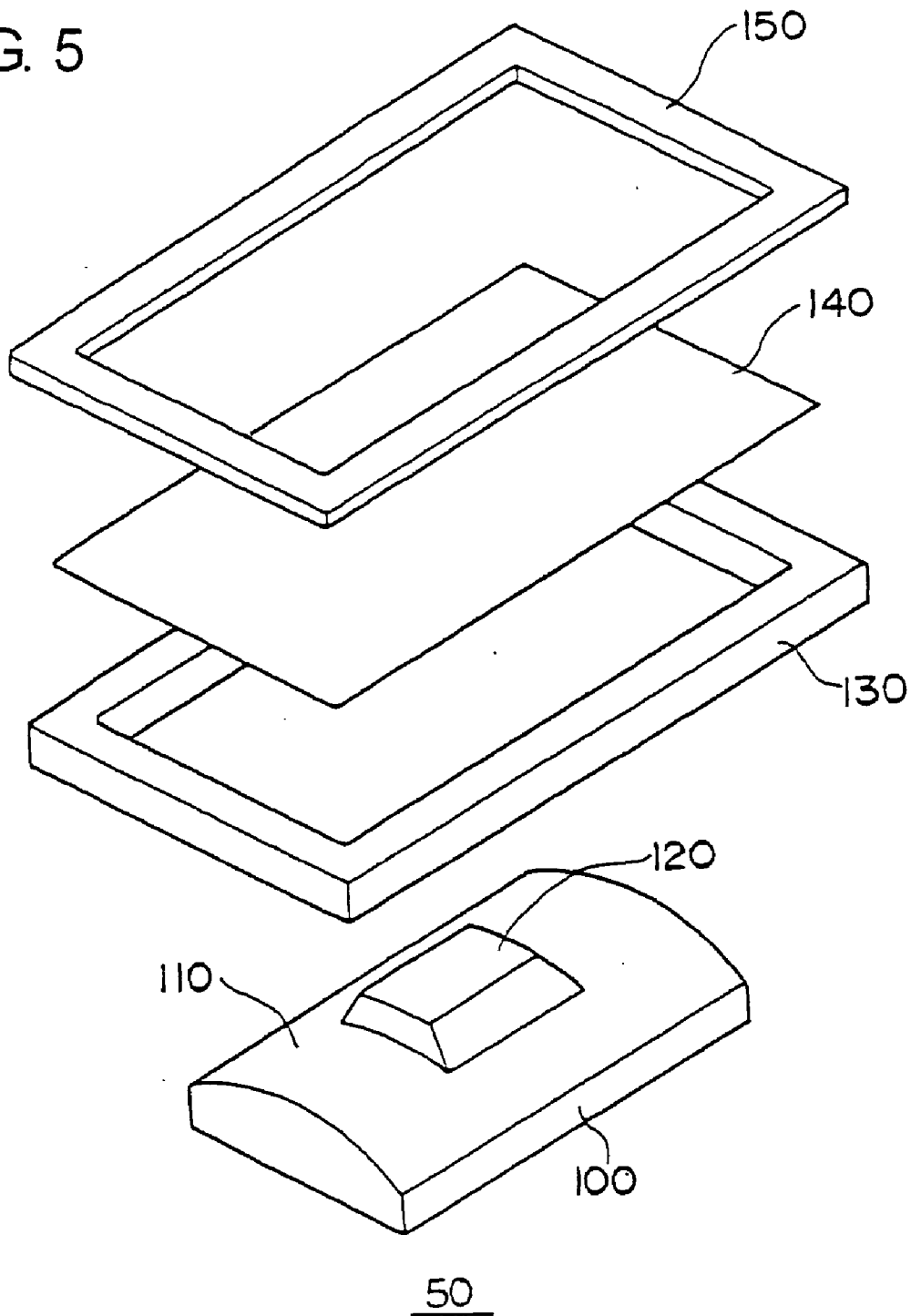

FIG. 6

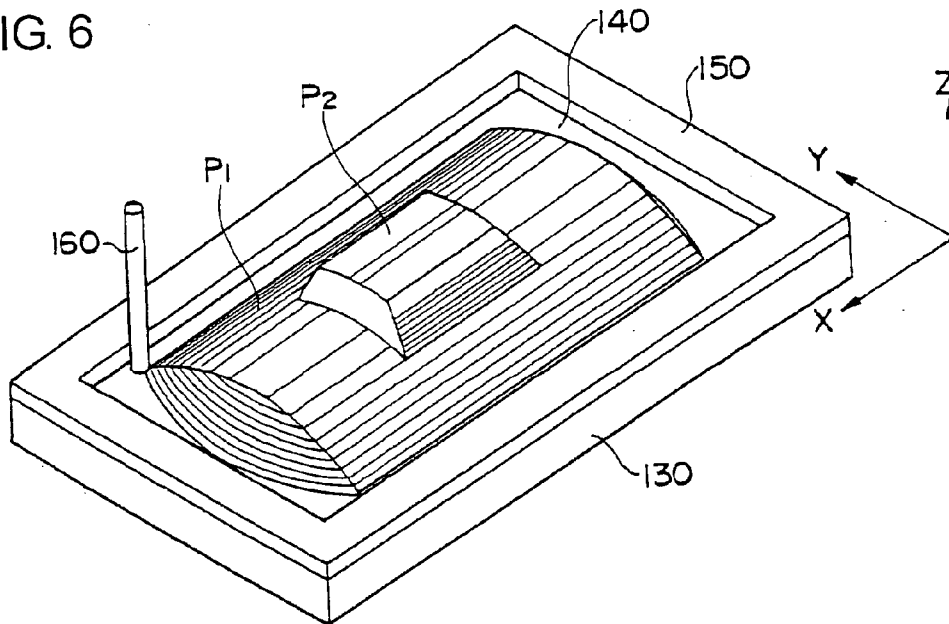

FIG. 7

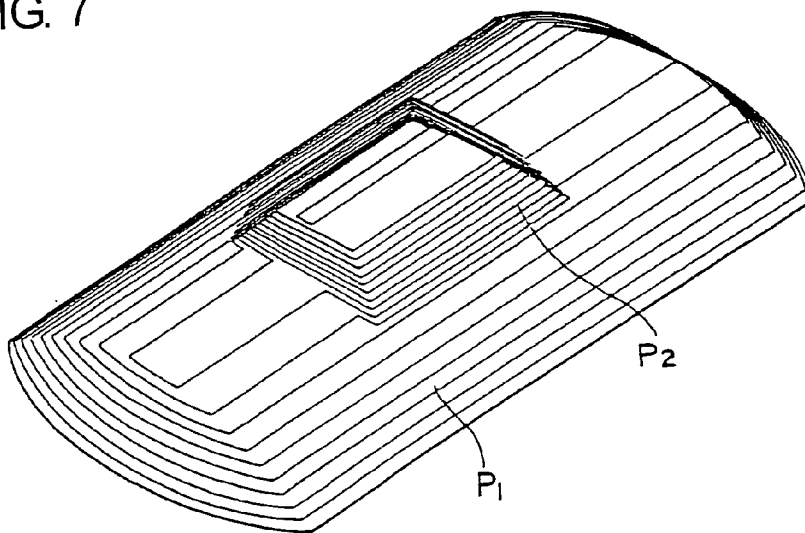

FIG. 8

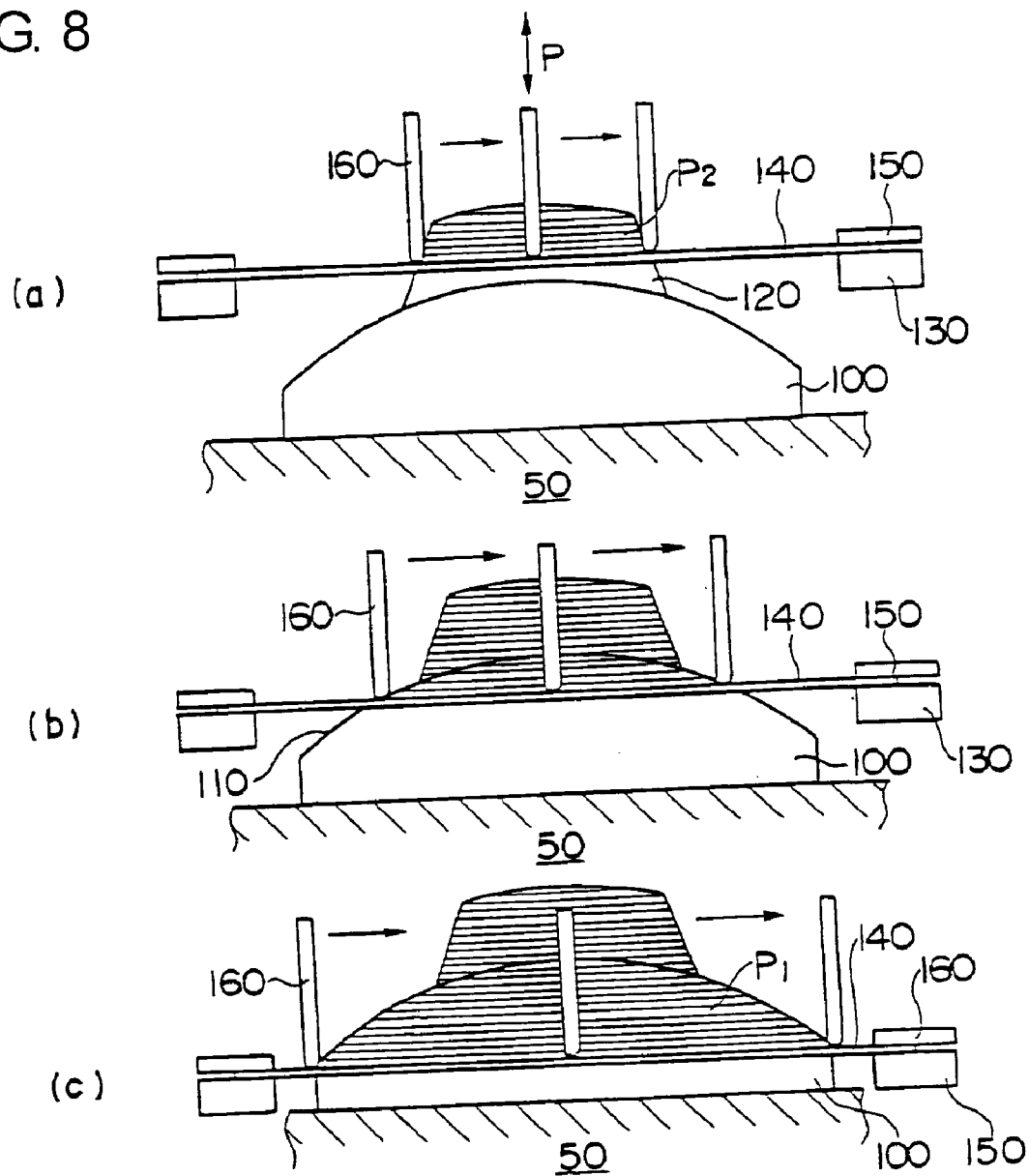
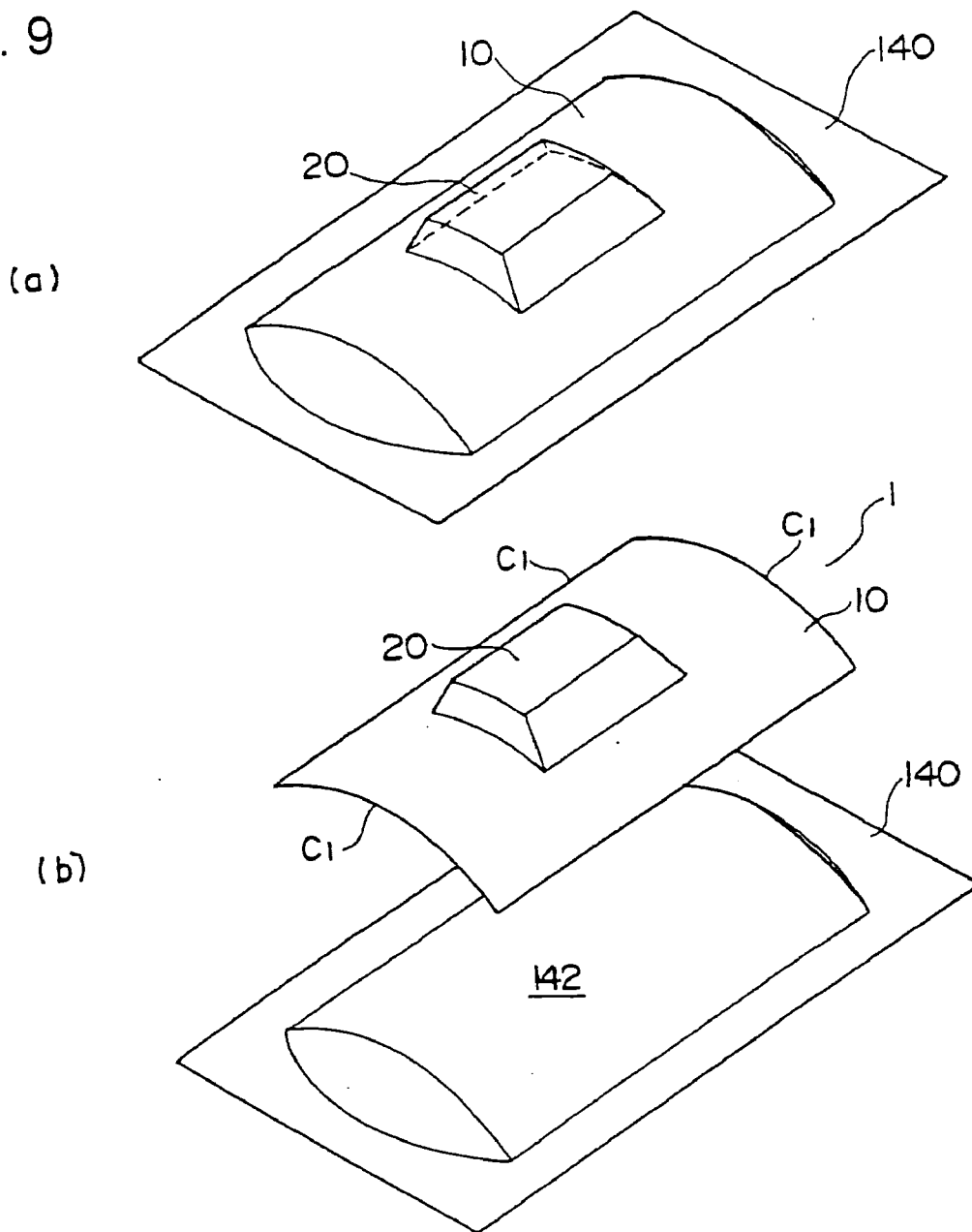

FIG. 9



## METHOD AND APPARATUS FOR INCREMENTAL FORMING

### FIELD OF THE INVENTION

[0001] The present invention relates to an incremental forming method and an incremental forming apparatus.

### DESCRIPTION OF THE RELATED ART

[0002] Patent document 1, Japanese Patent Laid-Open Publication No. 2002-1444 (European Patent Application Publication No. 1147832 A2) discloses an incremental forming method according to which a rod shaped tool is applied to the surface of a metal plate material and incremental forming is performed by shaping the plate member with the tool along a contour line corresponding to the shape of the product to be formed.

[0003] FIG. 1 is a perspective view showing the product manufactured through incremental forming that applies the present invention.

[0004] The product, the whole structure of which being designated by reference number 1, comprises a primary form portion 10 having a two-dimensional curved cross-sectional shape, and a secondary form portion 20 having a three-dimensional shape and protruding from the center of the primary form portion 10.

[0005] FIGS. 5 through 9 illustrate the conventional process for manufacturing the product 1 through conventional incremental forming.

[0006] A forming jig 100 disposed on a table 50 includes a first mold member 110 corresponding to the primary form portion 10 of the product and a second mold member 120 corresponding to the secondary form portion 20 of the product.

[0007] A metal plate 140 being the workpiece (base material) is a flat plate-shaped member, having its periphery supported by a workpiece holder 130 and a workpiece clamp 150. The workpiece holder 130 can be lowered from the peak area of the second mold member. An incremental forming tool 160 has an axis that is disposed along the perpendicular direction Z, and is capable of moving both in the horizontal direction X, Y and perpendicular direction Z.

[0008] FIG. 6 is a schematic view of the conventional incremental forming, and FIG. 7 shows the forming path.

[0009] As illustrated in FIGS. 6 and 7, incremental forming is performed throughout the whole workpiece via a path P<sub>1</sub> for forming the first form portion and a path P<sub>2</sub> for forming the second form portion, thereby shaping the workpiece to create a product.

[0010] As shown in FIG. 8, during incremental forming, the incremental forming tool 160 moves along the X-Y axis parallel to the upper surface of a plate-shaped workpiece 140, while moving in the Z axis direction corresponding to a pitch P at a time. Though there are plural incremental forming tools 160 illustrated in each of the drawings in FIG. 8, actually there is only one incremental forming tool. Three tools 160 are illustrated in each drawing to show that the tool is moved along a contour line.

[0011] When the pitch P for moving the tool in the Z direction is constant, the forming of the workpiece is pro-

gressed along a contour line. If the radius of curvature of the curved plane of the first form portion is large, the distance between the adjacent paths is widened, deteriorating formability.

[0012] However, if the pitch is narrowed to improve formability and to overcome the above problem, another drawback is caused in that the total length of the form path is increased and the total work time lengthened.

[0013] FIG. 9(a) shows a state in which the incremental forming process is completed and a primary form portion 10 and a secondary form portion 20 are created on the workpiece 140.

[0014] Thereafter, the workpiece 140 is subjected to an appropriate trimming process C<sub>1</sub> for trimming the peripheral area of the workpiece to correspond to the product, thereby forming the product 1.

[0015] After the trimming process, the workpiece 140 is left with an end material having a space 142 from which the product is cut out by the trimming, which causes deterioration of the yield factor of the material.

### SUMMARY OF THE INVENTION

[0016] Therefore, the present invention aims at providing a method and apparatus for incremental forming that overcomes the above-mentioned problems of the prior art.

[0017] In order to achieve the above object, the three-dimensional incremental forming method according to the present invention involves preparing a workpiece having a curved plane corresponding to the primary form portion, and forming a three-dimensional secondary form portion to a part of this workpiece via incremental forming.

[0018] The incremental forming apparatus according to the present invention comprises a table mounting a workpiece holder and a workpiece clamp for holding the periphery of a workpiece, and an incremental forming tool disposed to have its axial direction perpendicular to the table, wherein the workpiece holder and the workpiece clamp have curved surfaces that correspond to the curved plane of the workpiece.

### BRIEF DESCRIPTION OF THE DRAWINGS

[0019] FIG. 1 is a perspective view of the product formed according to the present invention;

[0020] FIG. 2 is a perspective view of the device used in the present invention;

[0021] FIG. 3 is an explanatory view illustrating the preferred embodiment of the present invention;

[0022] FIG. 4 is an explanatory view illustrating the preferred embodiment of the present invention;

[0023] FIG. 5 is a perspective view showing the device used according to the prior art;

[0024] FIG. 6 is an explanatory view showing the incremental forming according to the prior art;

[0025] FIG. 7 is an explanatory view showing the incremental forming according to the prior art;

[0026] FIG. 8 is an explanatory view showing the incremental forming according to the prior art; and

[0027] FIG. 9 is an explanatory view showing the incremental forming according to the prior art.

#### DETAILED DESCRIPTION OF THE PREFERRED EMBODIMENT

[0028] FIGS. 2 through 4 are explanatory views illustrating the method for creating a product by the incremental forming according to the present invention.

[0029] According to the present invention, a forming jig 200 positioned on a table 50 comprises only a mold member 220 corresponding to a secondary form portion of the product.

[0030] A metal plate 240 being the workpiece (material) is formed in advance into a curved plate having a two-dimensional curved surface that corresponds to a primary form portion of the product.

[0031] A workpiece holder 230 comprises a holder surface 232 that corresponds to the curved surface of the workpiece 240. Similarly, a workpiece clamp 250 has a clamp surface 252 that corresponds to the curved surface of the workpiece 240.

[0032] During the forming process, an incremental forming tool 260 and the table are relatively moved along the planar shape of the secondary form portion on an X-Y plane, and when the incremental forming tool 260 is relatively moved in the Y axis direction, the tool 260 is controlled so that it moves along the primary form portion, that is, along the curved surface of the workpiece 240.

[0033] Along with the advancement of the forming process, the incremental forming tool 260 is advanced by a predetermined pitch  $P_2$  to create the secondary form portion, in a manner similar to the conventional incremental forming.

[0034] As shown in FIG. 4, since according to the present invention a two-dimensional curve is provided in advance to the workpiece 240 and only the secondary form portion

having a three-dimensional structure is processed by incremental forming, the form path can be shortened greatly and the work time cut down.

What is claimed is:

1. An incremental forming method for forming a product comprising a primary form portion having a cross-section with a two-dimensional curved plane and a secondary form portion having a three-dimensional shape formed to a part of the primary form portion, the incremental forming method comprising:

preparing a workpiece having a curved plane corresponding to the primary form portion; and

forming the secondary form portion having the three-dimensional shape to a part of the workpiece via incremental forming.

2. The incremental forming method according to claim 1, wherein

during the incremental forming process for forming the secondary form portion, an incremental forming tool is moved along a path parallel to the curved plane of the primary form portion.

3. An incremental forming apparatus comprising:

a table mounting a workpiece holder and a workpiece clamp for holding a periphery of a workpiece; and

an incremental forming tool having an axis disposed substantially perpendicular to the table;

wherein the workpiece holder and the workpiece clamp have curved surfaces corresponding to a curved surface of the workpiece.

4. The incremental forming apparatus according to claim 3, further comprising a forming jig having a shape corresponding only to a secondary form portion.

\* \* \* \* \*