

(12) STANDARD PATENT
(19) AUSTRALIAN PATENT OFFICE

(11) Application No. **AU 2010260186 B2**

(54) Title
Method and system for discontinuous reception operation for long term evolution advanced carrier aggregation

(51) International Patent Classification(s)
H04W 76/04 (2009.01)

(21) Application No: **2010260186** (22) Date of Filing: **2010.06.15**

(87) WIPO No: **WO10/147956**

(30) Priority Data

(31) Number	(32) Date	(33) Country
61/220,886	2009.06.26	US
61/187,095	2009.06.15	US

(43) Publication Date: **2010.12.23**

(44) Accepted Journal Date: **2013.11.28**

(71) Applicant(s)
Research In Motion Limited

(72) Inventor(s)
Fong, Mo-Han;McBeath, Sean;Cai, Zhijun;Earnshaw, Mark;Heo, Youn Hyung;Yu, Yi

(74) Agent / Attorney
Spruson & Ferguson, L 35 St Martins Tower 31 Market St, Sydney, NSW, 2000

(56) Related Art
NOKIA CORPORATION et al: "Improvements for LTE-Advanced MAC", R2-092061, 3GPP TSG-RAN WG2 Meeting #65bis, Seoul, Korea, 23-27 March 2009
HUAWEI: "Carrier aggregation in active mode", R2-093104, 3GPP TSG-RAN WG2 Meeting #66, San Francisco, USA, 4-8 May 2009
ERICSSON: "Carrier aggregation in LTE-Advanced", R1-082468, TSG-RAN WG1 #53bis, Warsaw, Poland, 30 June - 4 July 2008
ERICSSON: "DRX with Carrier Aggregation in LTE-Advanced", Tdoc R2-092959, 3GPP TSG-RAN WG2 #66, San Francisco, USA, 4-8 May 2009
CATT: "Consideration on DRX", R2-092992, 3GPP TSG-RAN WG2 Meeting #66, San Francisco, USA, 4-8 May 2009



(51) International Patent Classification:
H04W 76/04 (2009.01)

(21) International Application Number:
PCT/US2010/038628

(22) International Filing Date:
15 June 2010 (15.06.2010)

(25) Filing Language: English

(26) Publication Language: English

(30) Priority Data:
61/187,095 15 June 2009 (15.06.2009) US
61/220,886 26 June 2009 (26.06.2009) US

(71) Applicant (for all designated States except US): **RESEARCH IN MOTION LIMITED** [CA/CA]; 295 Phillips Street, Waterloo, Ontario 2N1 3W8 (CA).

(72) Inventors; and

(75) Inventors/Applicants (for US only): **FONG, Mo-Han** [CA/CA]; 13750-4000 Innovation Drive, Kanta, Ontario 2K2 3K1 (CA). **MCBEATH, Sean** [CA/US]; 63994-5000 Riverside Drive, Brazos East, Building 6, Suite 100, Irving, Texas 75039 (US). **CAI, Zhijun** [CN/US]; 63775-5000 Riverside Drive, Brazos East, Building 5, Irving, Texas 75039 (US). **EARNSHAW, Mark** [CA/CA]; 13208-4000 Innovation Drive, Kanta, Ontario K2K 3K1 (CA). **HEO, Youn Hyung** [KR/CA]; 78357-305 Phillip Street, Waterloo, Ontario N2L 3W8 (CA). **YU, Yi** [CN/US]; 63942-5000 Riverside Drive, Building 6, Suite 100, Irving, Texas 75039 (US).

(74) Agents: **AGARWAL, Brij K.** et al.; Eckert Seamans Cherin & Mellott, LLC, 600 Grant Street, 44th Floor, Pittsburgh, Pennsylvania 15219 (US).

(81) Designated States (unless otherwise indicated, for every kind of national protection available): AE, AG, AL, AM, AO, AT, AU, AZ, BA, BB, BG, BH, BR, BW, BY, BZ, CA, CH, CL, CN, CO, CR, CU, CZ, DE, DK, DM, DO, DZ, EC, EE, EG, ES, FI, GB, GD, GE, GH, GM, GT, HN, HR, HU, ID, IL, IN, IS, JP, KE, KG, KM, KN, KP, KR, KZ, LA, LC, LK, LR, LS, LT, LU, LY, MA, MD, ME, MG, MK, MN, MW, MX, MY, MZ, NA, NG, NI, NO, NZ, OM, PE, PG, PH, PL, PT, RO, RS, RU, SC, SD, SE, SG, SK, SL, SM, ST, SV, SY, TH, TJ, TM, TN, TR, TT, TZ, UA, UG, US, UZ, VC, VN, ZA, ZM, ZW.

(84) Designated States (unless otherwise indicated, for every kind of regional protection available): ARIPO (BW, GH, GM, KE, LR, LS, MW, MZ, NA, SD, SL, SZ, TZ, UG, ZM, ZW), Eurasian (AM, AZ, BY, KG, KZ, MD, RU, TJ, TM), European (AL, AT, BE, BG, CH, CY, CZ, DE, DK, EE, ES, FI, FR, GB, GR, HR, HU, IE, IS, IT, LT, LU, LV, MC, MK, MT, NL, NO, PL, PT, RO, SE, SI, SK, SM, TR), OAPI (BF, BJ, CF, CG, CI, CM, GA, GN, GQ, GW, ML, MR, NE, SN, TD, TG).

Published:

- with international search report (Art. 21(3))
- before the expiration of the time limit for amending the claims and to be republished in the event of receipt of amendments (Rule 48.2(h))

[Continued on next page]

(54) Title: METHOD AND SYSTEM FOR DISCONTINUOUS RECEPTION OPERATION FOR LONG TERM EVOLUTION ADVANCED CARRIER AGGREGATION

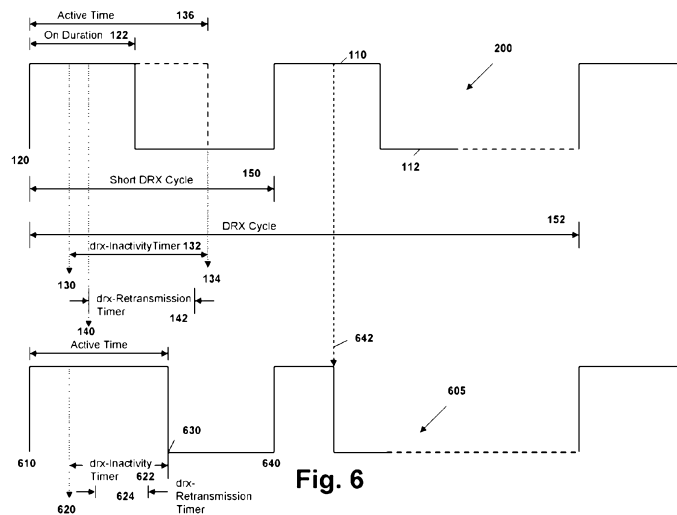

Fig. 6

(57) Abstract: A method for discontinuous reception operation for carrier aggregation comprising: receiving a first set of discontinuous reception parameters for a first carrier and a different set of discontinuous reception parameters for a second carrier; and configuring discontinuous reception parameters on the first carrier and second carrier.

WO 2010/147956 A3

WO 2010/147956 A3



(88) Date of publication of the international search report:

30 June 2011

METHOD AND SYSTEM FOR DISCONTINUOUS RECEPTION OPERATION FOR LONG TERM EVOLUTION ADVANCED CARRIER AGGREGATION

FIELD OF THE DISCLOSURE

[0001] The present disclosure relates to long term evolution-advanced (LTE-A), and in particular to discontinuous reception when carrier aggregation is utilized in LTE-A.

BACKGROUND

[0002] Discontinuous reception allows a user equipment (UE) to turn off its radio transceiver during various periods in order to save battery life on the UE. In the long term evolution (LTE) specifications, the UE is allowed to proceed into discontinuous reception (DRX) even when in a connected mode. DRX operation is defined for single carrier operation in LTE Release 8, in 3GPP TS 36.321, sections 3.1 and 5.7, the contents of which are incorporated herein by reference.

[0003] In LTE Advanced (LTE-A) it is agreed that carrier aggregation may be used in order to support a wider transmission bandwidth for increased potential peak data rates to meet the LTE-A requirements. In carrier aggregation, multiple component carriers are aggregated and they can be allocated in a subframe to a UE. Thus, each component carrier may have a bandwidth of, for example, 20 MHz and a total aggregated system bandwidth of up to 100 MHz. The UE may receive or transmit on multiple component carriers depending on its capabilities. Further, carrier aggregation may occur with carriers located in the same band and/or carriers located in different bands. For example, one carrier may be located at 2 GHz and a second aggregated carrier may be located at 800 MHz.

[0004] An issue arises with the translation of DRX operation from a single carrier LTE Rel-8 system to a multiple carrier LTE-A system. DRX under LTE Rel-8 may be inoperable or inefficient when multiple carriers are used. Two approaches have been proposed at the LTE-A forum.

[0005] In R2-092959, "DRX with Carrier Aggregation in LTE-Advanced", a proposal is described in which different DRX parameters are configured independently for different component carriers and DRX is performed independently for each component carrier.

For example, one component carrier may utilize a short DRX cycle while another component carrier may utilize only long DRX cycles; or the DRX cycles configured for the different component carriers are completely independent of one another. A problem with this approach is the complexity for the UE to maintain different states or timers for different carriers. There may also be little benefit of having completely independent DRX cycles and timers between carriers. Since upper layer traffic is multiplexed across multiple carriers, it is the Evolved Node B (eNB) scheduler's decision to determine on which carrier an encoded packet should be transmitted.

[0006] In a second approach, outlined in R2-092992, "Consideration on DRX", DRX operation is only configured on the anchor carrier. Additional component carriers are allocated on an as needed basis during the "active time" of the anchor carrier.

[0007] However, the above two proposals do not provide details regarding the allocation and de-allocation of additional component carriers. Nor do they explicitly provide details as to the DRX operation of the various carriers.

SUMMARY

A first aspect of the present invention provides a method for enabling or disabling a carrier for a user equipment in a wireless network, the method comprising: receiving, by the user equipment, a carrier enable or disable command medium access control (MAC) control element over a downlink shared channel; and transmitting, by the user equipment, an acknowledgement of the carrier enable or disable command MAC control element; wherein the MAC control element comprises at least one of: a plurality of bit fields corresponding with carrier identifiers, each of said plurality of bit fields designating whether a carrier corresponding with the carrier identifier of the bit field should be enabled or disabled; an action time for when the carrier should be enabled or disabled; and a subframe within the radio frame with a subframe number equal to an action time.

Another aspect of the present invention provides a method for enabling or disabling a carrier for a user equipment in a wireless network including an evolved node B (eNB), the method comprising: transmitting, by the eNB, a carrier enable or disable command medium access control (MAC) control element over a downlink shared

channel; and receiving, by the eNB, an acknowledgement of the carrier enable or disable command MAC control element; wherein the MAC control element includes at least one of: a plurality of bit fields corresponding with carrier identifiers, each of said plurality of bit fields designating whether a carrier corresponding with the carrier identifier of the bit field should be enable or disabled; an action time for when the carrier should be enabled or disabled; and a subframe within the radio frame with a subframe number equal to an action time.

Another aspect of the present invention provides a method for enabling or disabling a carrier for a user equipment in a wireless network including an evolved node B (eNB), the method comprising: transmitting, by the eNB, a carrier enable or disable command medium access control (MAC) control element over a downlink shared channel; and receiving, by the eNB, an acknowledgment of the carrier enable or disable command MAC control element.

BRIEF DESCRIPTION OF THE DRAWINGS

[0008] The present disclosure will be better understood with reference to the drawings in which:

Figure 1 is a timing diagram showing DRX operation of a carrier in LTE Rel. 8;

Figure 2 is a timing diagram showing DRX operation in LTE-A in which a non- designated carrier has a DRX inactivity timer;

Figure 3 is a timing diagram showing DRX operation in LTE-A in which a non- designated carrier has no DRX inactivity timer set;

Figure 4 is a timing diagram showing DRX operation in LTE-A in which a first non-designated carrier includes a DRX inactivity timer and a second non-designated carrier does not have a DRX inactivity timer;

Figure 5 is a timing diagram showing DRX operation in LTE-A in which a non- designated carrier is set to activate upon activation of the associated designated carrier;

Figure 6 is a timing diagram showing DRX operation in LTE-A in which a non- designated carrier is set to activate upon activation of the associated designated carrier and further including a DRX inactivity timer;

Figure 7 is a timing diagram showing DRX operation in LTE-A in which a non- designated carrier has an On Duration timer value set;

Figure 8 is a timing diagram showing DRX operation in LTE-A in which a non-designated carrier has an On Duration timer value set and where the On Duration timer value is longer than an active time on the associated designated carrier;

Figure 9 is a timing diagram showing DRX operation in LTE-A in which a non-designated carrier has an On Duration timer value and a DRX inactivity timer value set;

Figure 10 is a timing diagram showing DRX operation in LTE-A in which a non-designated carrier has a drx-FollowDesignatedTimer timer value set;

Figure 11 is a timing diagram showing a non-designated carrier configured with a short and long DRX cycle;

Figure 12 is a block diagram illustrating a medium access control (MAC) control element (CE) for enabling or disabling carrier reception on a non-designated carrier;

Figure 13 is a block diagram illustrating a MAC CE to acknowledge the MAC CE of **Figure 12**;

Figure 14 is a block diagram illustrating a MAC CE for enabling or disabling carrier reception on multiple non-designated downlink carriers;

Figure 15 is a block diagram illustrating a MAC CE to acknowledge the MAC CE of **Figure 14**;

Figure 16 is a block diagram illustrating a MAC CE configured to enable or disable multiple downlink and uplink carriers;

Figure 17 is a block diagram illustrating a MAC CE to acknowledge the MAC CE of **Figure 16**;

Figure 18 is a block diagram of an exemplary mobile device capable of being used with the embodiments herein;

Figure 19 is a data flow diagram showing configuration of candidate carriers; and

Figure 20 is a data flow diagram showing control information configuration for a carrier and the stopping of transmission from a disabled carrier.

DETAILED DESCRIPTION

[0009] According to one aspect, there is provided a method for discontinuous reception operation for carrier aggregation comprising: receiving a first set of discontinuous reception parameters for a first carrier and a limited or different set of discontinuous reception parameters for a second carrier; and configuring discontinuous reception parameters on the first carrier and second carrier.

[0010] According to another aspect, there is provided a method for enabling or disabling carrier reception through medium access control element signaling comprising: adding a carrier reception enable or disable command control element; and configuring a carrier reception enable or disable acknowledgment control element

[0011] DRX operation may be used for different purposes. For example, a UE that is currently experiencing a low level of traffic activity could be in a DRX state where it wakes up occasionally from DRX in order to receive traffic. An example of this could be that the UE is conducting a voice call. Voice packets have a predictable pattern of occurrence and do not need to be transmitted in every subframe, so a UE could be configured to spend the time between successive voice packet transmissions/receptions in DRX. Another example would be a UE that is currently essentially idle and has no traffic. The UE needs to wake up temporarily to see if the eNB has any traffic for the UE.

[0012] DRX could also be used for resource sharing purposes. It is unlikely that a particular UE would have data transmission and/or receptions in every subframe on a sustained basis. Thus, for signaling efficiency reasons, it may be more desirable to consolidate data into fewer and larger resource allocations if the additional latency can be tolerated. Such latency would in general be minimal.

[0013] For instance, it may be more efficient to send a burst of 1000 bytes in one subframe, every 10 subframes, rather than ten 100 byte transmissions across each of those same 10 subframes. Due to the shared nature of the packet data channels, other UEs could utilize the data channels during the subframes where the UE in question is not receiving or transmitting. The UE could therefore be configured to enter DRX when the eNB knows that it would not transmit to the UE. The eNB would be transmitting to the other UEs in those subframes.

[0014] As will be appreciated by those skilled in the art, different DRX cycle lengths, such as 10 milliseconds for long DRX cycle and as short as 2, 5, 8 and 10 milliseconds for short DRX cycles exist, so the use of DRX functionality for this data channel sharing purpose may be possible. In addition, multiple UEs can be configured with the same DRX cycle length but with different start offsets. This would result in different sets of UEs waking up during different time intervals, thereby facilitating the time division among multiple UEs.

[0015] Reference is now made to **Figure 1**, which shows LTE Rel-8 operation. In **Figure 1**, an Active mode **110** is illustrated at a first level and a DRX mode **112** is illustrated at a second level. During Active mode **110**, the UE monitors the downlink control channel for possible resource allocation on the downlink or uplink traffic channels. At a time, illustrated by reference numeral **120**, a boundary of a DRX cycle is encountered. At this point, the mode changes from DRX mode **112** to Active mode **110**. Further, an OnDuration timer **122** is started. The OnDuration timer **122** signifies the duration that the UE should remain in Active mode, even if there is no traffic transmission to/from the UE during this duration.

[0016] In the example of **Figure 1**, within the Active mode, arrow **130** shows the last physical downlink control channel (PDCCH) message is received indicating a new packet transmission on the physical downlink shared channel (PDSCH) or uplink grant for new packet transmission on the physical uplink shared channel (PUSCH). At this point, a DRX Inactivity timer **132** is started. The DRX inactivity timer **132** specifies a number of consecutive PDCCH subframes after the most recent successful decoding of a PDCCH indicating an initial uplink or downlink user data transmission for the UE. As will be appreciated by those skilled in the art, in the example of **Figure 1**, the UE remains in an Active mode **110** until the expiration of a DRX inactivity timer **132**. The expiration of the DRX inactivity timer **132** is shown by arrow **134**, at which point the UE transitions to the DRX mode **112**.

[0017] The total duration between the time shown by reference numeral **120** and arrow **134** is referred to as the Active time **136**. The Active time **136** is related to DRX operation, as defined in sub clause 5.7 of the LTE Rel-8 DRX specification in 3GPP TS 36.321, and defines the subframes during which the UE monitors the PDCCH.

[0018] The last data packet sent, shown by arrow **130**, may expect a hybrid automatic repeat request (HARQ) retransmission. The first point at which the HARQ retransmission may be expected is shown by arrow **140**. At this point, if an HARQ retransmission is required by the UE, a DRX retransmission timer **142** is started during which period the HARQ retransmission may be received. If the HARQ retransmission is not received, the DRX retransmission timer expires at **143**. When either the DRX inactivity timer is running or the DRX retransmission timer is running, the UE remains in Active time.

[0019] As will be appreciated, based on the above, the Active time **136** can therefore potentially be extended by data activity, which may result in the DRX inactivity timer being reset. Further, if HARQ retransmission is expected for a previously transmitted PDSCH packet, the corresponding DRX retransmission timer is started, causing the Active time **136** to be extended.

[0020] If the UE is configured for a short DRX cycle, a new Active mode **110** is started at the end of the short DRX cycle, as illustrated by arrow **150** in **Figure 1**. Arrow **150** shows the DRX cycle which specifies the periodic repetition of the OnDuration, followed by a period of possible inactivity.

[0021] It is also possible to have a long DRX cycle **152** as shown in **Figure 1**. In general, a long DRX cycle **152** is larger than the short DRX cycle, and both may be configured by the eNB.

[0022] The UE may be configured by Radio Resource Control (RRC) with DRX functionality that controls the UE's PDCCH monitoring activity for the UE's Cell Radio Network Temporary Identifier (C-RNTI), Transmit Power Control Physical Uplink Control Channel RNTI (TPC-PUCCH-RNTI), Transmit Power Control Physical Uplink Shared Channel RNTI (TPC-PUSCH-RNTI) and semi-persistent scheduling C-RNTI (SPS C-RNTI) (if configured). When in RRC_CONNECTED, if DRX is configured, the UE is allowed to monitor the PDCCH discontinuously using the DRX operation specified by sub clause 5.7 of the LTE Rel-8 specification 3GPP TS 36.321. Otherwise the UE monitors the PDCCH continuously. When using DRX operation, the UE also monitors the PDCCH according to requirements found in other sub clauses of the specification. RRC controls DRX operation by configuring the following: OnDuration timer, DRX-InactivityTimer, DRX-RetransmissionTimer (one per DL HARQ process except for the broadcast process), the value of the DRX Start Offset, which is the subframe where the DRX cycle starts, and optionally the DRX Short Cycle Timer and Short DRX-Cycle. An HARQ retransmission timer (RTT) parameter, which specifies the minimum amount of subframes before downlink HARQ retransmission is expected from the UE, is also defined per downlink HARQ process.

[0023] Section 5.7 of the LTE Rel. 8 specification 3GPP TR 36.321 provides for the above as:

When a DRX cycle is configured, the Active Time includes the time while:

- *onDurationTimer* or *drx-InactivityTimer* or *drx-RetransmissionTimer* or *mac-ContentionResolutionTimer* (as described in subclause 5.1.5) is running; or
- a Scheduling Request sent on PUCCH is pending (as described in subclause 5.4.4); or
- an uplink grant for a pending HARQ retransmission can occur and there is data in the corresponding HARQ buffer; or
- a PDCCH indicating a new transmission addressed to the C-RNTI of the UE has not been received after successful reception of a Random Access Response for the explicitly signaled preamble (as described in subclause 5.1.4).

When DRX is configured, the UE shall for each subframe:

- If the Short DRX Cycle is used and $[(SFN * 10) + \text{subframe number}] \bmod (\text{shortDRX-Cycle}) = (\text{drxStartOffset}) \bmod (\text{shortDRX-Cycle})$; or
- if the Long DRX Cycle is used and $[(SFN * 10) + \text{subframe number}] \bmod (\text{LongDRX-Cycle}) = \text{drxStartOffset}$:
 - start *onDurationTimer*.
- if a HARQ RTT Timer expires in this subframe and the data in the soft buffer of the corresponding HARQ process was not successfully decoded:
 - start the *drx-RetransmissionTimer* for the corresponding HARQ process.
- if a DRX Command MAC control element is received:
 - stop *onDurationTimer*;
 - stop *drx-InactivityTimer*.
- if *drx-InactivityTimer* expires or a DRX Command MAC control element is received in this subframe:
 - if the short DRX cycle is configured:
 - start or restart *drxShortCycleTimer*;
 - use the Short DRX Cycle.
 - else:
 - use the Long DRX cycle.
- if *drxShortCycleTimer* expires in this subframe:
 - use the long DRX cycle.
- during the Active Time, for a PDCCH-subframe except if the subframe is required for uplink transmission for half-duplex FDD UE operation and except if the subframe is part of a configured measurement gap:
 - monitor the PDCCH;
 - if the PDCCH indicates a DL transmission or if a DL assignment has been configured for this subframe:
 - start the HARQ RTT Timer for the corresponding HARQ process;

- stop the *drx-RetransmissionTimer* for the corresponding HARQ process.
- if the PDCCH indicates a new transmission (DL or UL):
 - start or restart *drx-InactivityTimer*.
- when not in Active Time, CQI/PMI/RI on PUCCH and SRS shall not be reported.

Regardless of whether the UE is monitoring PDCCH or not the UE receives and transmits HARQ feedback when such is expected.

NOTE: A UE may optionally choose to not send CQI/PMI/RI reports on PUCCH and/or SRS transmissions for up to 4 subframes following a PDCCH indicating a new transmission (UL or DL) received in the last subframe of active time. The choice not to send CQI/PMI/RI reports on PUCCH and/or SRS transmissions is not applicable for subframes where *onDurationTimer* is running.

[0024] DRX IN LTE-A.

[0025] In accordance with the present disclosure, various embodiments for utilizing DRX in LTE-A to support carrier aggregation are provided.

[0026] In one embodiment, the UE should have a minimum number of component carriers for which it needs to turn on signal reception while meeting traffic demand. Having completely independent DRX cycles among component carriers assigned to a UE may cause unnecessary complexity and power consumption at the UE. In one embodiment it is possible to have coordinated DRX cycles among component carriers assigned to a UE.

[0027] Various differences between LTE and LTE-A may affect DRX operation and therefore may need to be addressed by LTE-A DRX solutions.

[0028] A first difference is that LTE has one downlink and one uplink carrier. There is a one-to-one mapping between these two carriers. Conversely, in LTE-A, there may not only be multiple downlink and/or multiple uplink carriers, but the number of downlink and the number of uplink carriers may be different. There may consequently be no direct one-to-one association between downlink and uplink carriers.

[0029] As will be appreciated, in both LTE and LTE-A HARQ feedback must always be received and transmitted as expected while the UE is in DRX operation. In the case of LTE-A with carrier aggregation, this implies that the corresponding component carriers in

the downlink and uplink must be kept Active in order to receive or transmit this information.

[0030] In LTE, resource indications on the PDCCH correspond with either the same downlink carrier or the associated uplink carrier since there is only one carrier in each link direction. In LTE-A, PDCCH signaling on one carrier such as the anchor carrier could be associated with transmissions or receptions on multiple other uplink or downlink carriers. As will be appreciated by those in the art, an “anchor carrier” may also be referred to as a “primary carrier” and a “non-anchor carrier” may also be referred to as a “secondary carrier”.

[0031] A further distinction between the two is that, as a result of having the PDCCH on one carrier associating with receptions on multiple other uplink or downlink carriers, a UE expecting HARQ retransmissions only on one carrier (e.g. non-anchor carrier) may also need to keep receiving a different carrier (e.g. anchor carrier) in order to receive PDCCH information about potential HARQ retransmissions.

[0032] Furthermore, an LTE-A UE with multiple aggregated carriers will have a large number of HARQ processes. If any of the HARQ processes potentially expects an HARQ retransmission, the UE can be in Active time. Due to the large number of HARQ processes, the probability that the UE will be in Active time and consequently the proportion of time spent in Active time may be much higher for LTE-A than for LTE.

[0033] Carrier Configuration

[0034] When the UE is in an RRC_CONNECTED state, it can be assigned N component carriers, where N is greater than or equal to 1. One or more of the N component carriers may be assigned as designated carriers. In one embodiment, a designated carrier is also an “anchor carrier”. The UE enables carrier reception on all the N component carriers. The term “carrier reception” is defined such that when the carrier reception of a component carrier is enabled for a UE, the UE enables the RF reception and/or reception of downlink physical control channels associated with this component carrier and downlink physical data channels on this component carrier. Carrier reception can also be called signal reception or some other term without deviating from the present disclosure. As will be appreciated by those in the art, if carrier reception of a component carrier is disabled for a UE, the UE stops decoding the

PDSCH, the PDCCH and other control channels associated with this component carrier, regardless of whether the PDCCH is transmitted on the same carrier as the PDSCH resource allocation or on a different carrier. The UE may monitor the PDCCH on only one or more of the designated carriers, on a subset of the N component carriers, or on all N component carriers. If the UE detects a PDCCH that assigns a PDSCH resource on a particular component carrier, the UE performs baseband demodulation and decoding of the assigned PDSCH resource on that component carrier.

[0035] The eNB can change the set of N component carriers by adding new component carriers to the set or removing existing component carriers from the set. The eNB can also change one or more of the designated carriers.

[0036] The UE can be configured by RRC signaling with DRX functionality that controls the UE's carrier reception on one or multiple component carriers. As used herein, the DRX parameters have similar definitions to those defined in LTE Rel-8, and include the onDurationTimer, drx-InactivityTimer, drx-RetransmissionTimer (one per downlink HARQ process, except for the broadcast process), the long DRX-Cycle, the value of the drxStartOffset and optionally the drxShortCycleTimer and shortDRX-Cycle. An HARQ retransmission timer per downlink HARQ process, except for the broadcast process, is also defined. The above is not meant to be limiting and other DRX parameters can also be used for various component carriers including the designated carriers.

[0037] The non-designated carriers could also have various DRX timers and parameters. In one embodiment, the non-designated carriers may have timers such as the drx-InactivityTimer, drx-RetransmissionTimer, and HARQ RTT Timer (with the latter two timers existing for each downlink HARQ process). The drx-InactivityTimer may however be omitted in various embodiments and thus the only parameters used consist of the drx-RetransmissionTimer and the HARQ RTT Timer expiry time settings. In other embodiments, there can be a reduced set of DRX parameters for the non-designated carriers. Different non-designated carriers may have different reduced sets of DRX parameters. In yet another embodiment, some non-designated carriers can be configured with a full set of DRX parameters while other non-designated carriers are configured with a reduced set of DRX parameters. In further embodiments, all non-designated carriers may have the same set of DRX parameters, either full or reduced. In a further embodiment, the eNB needs only signal one set of parameters for all non-designated carriers.

[0038] DRX parameters are signaled by the eNB to the UE through RRC signaling. The eNB can configure the DRX parameters on the designated carrier(s) and M other non-designated component carriers, where M is greater than or equal to 0. These designated carriers and M non-designated component carriers are those for which the eNB may potentially instruct the UE to enable carrier reception. In one embodiment, the eNB may instruct the UE to enable carrier reception on a component carrier which is not within the set of designated carrier(s) and M non-designated carriers. In another embodiment, all M non-designated component carriers have the same DRX configurations, and hence only one common signaling is needed instead of M individual settings. In a further embodiment, for a designated carrier or a non-designated carrier on which DRX parameters are configured, the eNB can explicitly signal the UE to enable or disable the DRX operation. When DRX operation is enabled for a carrier, the UE performs DRX operation as specified by the DRX parameters. When DRX operation is disabled, the UE remains in Active mode on that carrier if the carrier reception on that carrier has been previously enabled.

[0039] From the above, the set of N carriers are called the Active carriers, while the set of designated carriers and M non-designated carriers on which DRX parameters are configured can be called the DRX-Configured carriers. The set of DRX-Configured carriers and Active carriers may or may not overlap. The set of Active carriers may also be a subset of the set of the DRX-Configured carriers or vice-versa.

[0040] In addition to the Active carriers and DRX-Configured carriers, a UE may be pre-allocated additional component carriers where a logical carrier index is assigned to map to a specific physical carrier. The set of carriers where a logical carrier index is assigned is called the candidate carriers. The UE is also signaled, through unicast or broadcast signaling from the eNB, the properties of the candidate carriers including carrier frequency, bandwidth, control channels support, etc. DRX operation can be configured for one or more carriers within the set of candidate carriers. UE reception of a carrier within the set of candidate carriers can be enabled through explicit signaling (e.g., RRC signaling or MAC CE) from the eNB, or implicitly through the DRX parameter configuration. This is for example shown in **Figure 19**, where eNB **1910** sends a message **1930** to UE **1920**. Message **1930** provides information for carrier configuration, including a carrier logical index. The carrier can then be configured at UE **1920**, as shown by arrow **1940**.

[0041] In one embodiment, non-designated carriers within the set of M , where M is defined above, are associated with a designated carrier. One or more non-designated carriers can be associated with one of the designated carriers. The association is signaled by the eNB (e.g. through RRC signaling) to the UE. In one embodiment, the eNB signals the DRX parameters and the association information to the UE in the same RRC signaling message. In another embodiment, the association can be implicit through a predefined mapping of the logical/physical carrier index of a non-designated carrier to a designated carrier. In yet another embodiment, the association between a non-designated carrier and a designated carrier can be signaled by the eNB using broadcast or multicast signaling (e.g. broadcast or multicast RRC signaling) to multiple UEs in the cell.

[0042] In one embodiment, for each of the M non-designated carriers, where M is defined above, the carrier reception on that carrier can be enabled at the start of the OnDuration of the associated designated carrier, or it can be enabled during the Active time of the associated designated carrier. Such enabling may be through explicit eNB signaling to the UE (for example, PDCCH enabling signaling), or by some alternative means.

[0043] The two modes can be configured and signaled such as through RRC signaling or MAC CE by the eNB to the UE for each of the M non-designated carriers. In the latter mode, during the Active time on the associated designated carrier, the eNB may instruct the UE to enable carrier reception on another component carrier through control signaling. Such control signaling may include, but is not limited to, RRC signaling, PDCCH signaling, or MAC CE signaling. The signaling may be sent on the associated designated carrier or one of the N component carriers, where N is defined above.

[0044] One example of the above is that the UE enables carrier reception on one of the M non-designated carriers or on a carrier not within the set of M carriers, if the UE receives a grant or carrier enabled signaling with C-RNTI successfully in one of the N component carriers rather than with SPS C-RNTI, SI-RNTI (System Information RNTI), P-RNTI (Paging RNTI) or TPC RNTI. The action time to enable the carrier reception on the non-designated carrier can be implicit, such as x number of subframes after receiving the corresponding signal from the eNB, or may be explicitly indicated in the signaling message. In a specific embodiment, x could be 0.

[0045] At the action time, the UE enters Active time on the non-designated carrier. It is noted that if the carrier reception of a certain carrier is disabled, the UE can stop monitoring the PDCCH for this carrier regardless of whether the PDCCH is transmitted on the same carrier as the PDSCH resource allocation or on a different carrier. In one embodiment, if the carrier reception of a certain carrier is disabled, the UE can stop monitoring the PDCCH associated with this carrier regardless of whether the associated PDCCH is transmitted on this carrier or on a different carrier.

[0046] If the UE is indicated to enable carrier reception on a non-designated carrier, the UE could transmit control information corresponding to this non-designated carrier such as the Channel Quality Indicator (CQI), Precoding Matrix Indicator (PMI), Rank Indicator (RI), and Sounding Reference Symbol (SRS) prior to action time in a designated uplink carrier or an uplink carrier that is associated with the downlink non-designated carrier. This is, for example, shown with reference to **Figure 20**, in which eNB **2010** determines an activation time, as shown by arrow **2030**, and provides control information for carrier configuration, as shown by arrow **2040**, to UE **2020**, prior to activation time.

[0047] Further, when the carrier reception of a certain carrier is disabled, the UE may stop transmitting the uplink control information to the eNB corresponding to that particular carrier. This is, for example, shown in **Figure 20**, where carrier reception is disabled by either signaling, as shown by arrow **2050**, or DRX operation for the carrier, as shown by arrow **2055**. Upon the carrier reception being disabled, transmission on the carrier is also disabled, as shown by arrow **2060**. In one embodiment, the uplink control information corresponding to a non-designated carrier is only transmitted to the eNB during the Active time of the non-designated carrier. In a further embodiment, the control information contains control information for all or a subset of the N carriers, for example as combined control information. This control information is only transmitted during the Active time of any of the designated carrier(s) via the associated uplink carrier such as a "single report for all".

[0048] The above is demonstrated with regard to various embodiments below. These embodiments are not meant to be limiting, and can be used alone, in conjunction with other embodiments or various other alternatives that would be apparent to those skilled in the art having regard to the present disclosure are also contemplated.

[0049] 1. Explicit Start, Individual drx-InactivityTimer

[0050] In a first embodiment, the carrier reception on a non-designated carrier is enabled during the Active time of the associated designated carrier by eNB signaling. A drx-InactivityTimer for the non-designated carrier is started at the action time. The drx-InactivityTimer is restarted whenever a new PDSCH packet is received on the non-designated carrier. A drx-RetransmissionTimer is also maintained during the Active time of the non-designated carrier. The drx-RetransmissionTimer for an HARQ process is started at the earliest time when a retransmission may be expected for a previously transmitted packet on the corresponding HARQ process.

[0051] The drx-RetransmissionTimer for an HARQ process is disabled when a packet is received correctly for the HARQ process or the maximum number of retransmissions has been reached.

[0052] The UE remains in Active time on the non-designated carrier when either the carrier's drx-InactivityTimer or a drx-RetransmissionTimer is running. At any time during the Active time on the non-designated carrier, the eNB can instruct the UE, through signaling, to disable carrier reception on the non-designated carrier.

[0053] Carrier reception on the carrier is disabled when none of the drx-InactivityTimer and the drx-RetransmissionTimers are running.

[0054] Reference is now made to **Figure 2**. In **Figure 2**, a designated carrier **200**, with which the non-designated carrier **205** is associated, is shown to have similar properties to the carrier of **Figure 1**. In this regard, similar reference numerals are utilized.

[0055] Designated carrier **200** has an On Duration **122**, which starts at a time shown as reference numeral **120**. The UE then receives its last PDCCH message corresponding to a new data transmission on the designated carrier at a time shown by arrow **130**, at which point a drx-InactivityTimer **132** is restarted. Further, after the HARQ retransmission timer for a downlink HARQ process expires, the drx-RetransmissionTimer for the same downlink HARQ process **140** is started. This is the timer during which the UE waits to see whether an HARQ retransmission is received.

[0056] As shown in **Figure 1**, the drx-InactivityTimer **132** expires at a time shown by arrow **134**. This is subsequent to the expiration of drx-RetransmissionTimer **142**. At this point, the designated carrier **200** proceeds to a DRX mode. The Active time during which the UE monitors the PDCCH on the designated carrier is shown by arrow **136**.

[0057] If a short DRX cycle is configured, the designated carrier **200** proceeds back to an Active mode **110** after the short DRX cycle **150** expires. Conversely, if a long DRX cycle is configured then the designated carrier **200** proceeds back to an Active mode **110** after the expiration of the long DRX cycle **152**.

[0058] At some point the eNB realizes that there is more data to be sent to the UE and sends a signal to start a second (or subsequent) component carrier. A non-designated carrier **205** is started as a result of a message shown at arrow **210** to enable carrier reception on a component carrier.

[0059] In accordance with the first embodiment, a drx-InactivityTimer is associated with the component carrier. The drx-InactivityTimer may have a preconfigured length or the length of the drx-InactivityTimer may be signaled by the eNB.

[0060] On receipt of the signal (or the corresponding action time) shown by arrow **210**, the non-designated carrier **205** proceeds to an Active mode, i.e. the UE enables carrier reception on the non-designated carrier **205**. During the Active mode, the last new PDSCH packet is received on the non-designated carrier, as shown by arrow **220**. At this point the drx-InactivityTimer **222** is restarted. Also started after the HARQ RTT time is the drx-RetransmissionTimer **224**.

[0061] In the example of **Figure 2**, an HARQ retransmission is received and the drx-RetransmissionTimer **224** is stopped.

[0062] Upon the expiration of the drx-InactivityTimer **222** the non-designated carrier **205** has its reception disabled, as shown by reference numeral **230**. At this point, the eNB can signal through the associated designated carrier **200** to re-enable reception on the non-designated carrier **205** at some future point.

[0063] 2. Explicit Signaling, No drx-InactivityTimer

[0064] In a further embodiment, carrier reception on a non-designated carrier is enabled during the Active time of the associated designated carrier by eNB signaling. A separate drx-InactivityTimer is not maintained for a non-designated carrier. At the action time, the UE enables carrier reception on the non-designated carrier assigned by the eNB. The UE continues to enable carrier reception on the non-designated carrier during the Active time of the designated carrier, unless explicit signaling is received from the eNB to instruct the UE to disable carrier reception on the non-designated carrier. Since the HARQ retransmission process occurs independently between the associated designated carrier and each of the non-designated carriers, each of these carriers maintains its own drx-RetransmissionTimer for each of its downlink HARQ processes. In one embodiment, the designated carrier shall remain in Active time when the drx-InactivityTimer for the designated carrier or at least one of the drx-RetransmissionTimers for the designated carrier or for any non-designated carriers associated with the designated carriers is running. In a further embodiment, the designated carrier can go into DRX even if one or more of the drx-RetransmissionTimers of the non-designated carriers associated with the designated carriers are still running.

[0065] Reference is now made to **Figure 3**. In **Figure 3**, designated carrier **200** with which the non-designated carrier **305** is associated, is similar to designated carrier **200** of **Figure 2**.

[0066] Non-designated carrier **305** associated with the designated carrier **200** has only a drx-RetransmissionTimer configured for each of its downlink HARQ processes.

[0067] As illustrated in **Figure 3**, explicit signaling is sent by the eNB to the UE to indicate to the UE to activate the non-designated carrier **305**. This is shown by arrow **310**. The non-designated carrier then goes into Active time for a period that is determined either by the Active time **136** of the associated designated carrier **200**, or as indicated above, may be determined by a drx-RetransmissionTimer.

[0068] Assuming that no drx-RetransmissionTimers are running, at **134**, designated carrier **200** moves into DRX. At the same time, the UE disables reception on the non-designated carrier **305**.

[0069] In a second Active period, the UE receives eNB signaling for the non-designated carrier **305** to enable reception, as shown by **320**. The reception is subsequently disabled by explicit eNB signaling to the UE, as shown by arrow **322**.

[0070] 3. Mixing of the embodiments **Figure 2** and **Figure 3**

[0071] Reference is now made to **Figure 4**. The DRX operation described in **Figure 2** and **Figure 3** above can occur at different times for the same UE, on the same or different non-designated carriers. When the eNB signals the UE to enable carrier reception for a non-designated carrier, the eNB can indicate to the UE whether to maintain the drx-InactivityTimer for that non-designated carrier. In one embodiment, if the eNB indicates to the UE to maintain the drx-InactivityTimer, the DRX operation described with regard to **Figure 2** above follows. Otherwise, DRX operation described with reference to **Figure 3** above follows. In other embodiments the signaling could be reversed, and the drx-InactivityTimer could be used unless explicit signaling indicates otherwise.

[0072] **Figure 4** shows signaling in which two non-designated carriers are activated. Namely, non-designated carrier **205** is activated with a message shown by arrow **210**. In the message of arrow **210**, the eNB signals that a drx-InactivityTimer should be utilized. Such signaling can, for example, be indicated with a single bit flag. In other embodiments, the signaling may include a value for the drx-InactivityTimer. Other signaling that the drx-InactivityTimer should be used is possible.

[0073] Based on the message of arrow **210**, the non-designated carrier **205** proceeds as indicated above with regard to **Figure 2**. At the expiration of the drx-InactivityTimer **222**, the non-designated carrier **205** proceeds to disable reception as shown at reference numeral **230**.

[0074] Similarly, non-designated carrier **305** is signaled to activate, as shown by reference numeral **310**. The signaling does not provide a drx-InactivityTimer or an indication that a drx-InactivityTimer should be utilized. In this regard, the Active time of non-designated carrier **305** follows the Active time **136** of the associated designated carrier **200**. An exception may occur if the drx-RetransmissionTimer is running.

[0075] Similarly, explicit signaling to enable reception on non-designated carrier **305** may be provided as illustrated by arrow **320** and explicit signaling to disable reception on non-designated carrier **305** may also be provided, as shown by arrow **322**.

[0076] 4. Inherent activation

[0077] In a further embodiment, at the start of the On Duration on the designated carrier, the UE enables carrier reception on a non-designated carrier associated with the designated carrier assigned by the eNB. The UE continues to enable carrier reception on the non-designated carrier during the Active time of the associated designated carrier, unless explicit signaling is received from the eNB to instruct the UE to disable carrier reception on the non-designated carrier.

[0078] Since the HARQ retransmission process occurs independently between the designated carrier and the non-designated carrier, each of the carriers maintains its own drx-RetransmissionTimers for each of its HARQ processes. The designated carrier remains in Active time when the drx-InactivityTimer for the designated carrier or at least one of the DRX retransmission timers for the designated carrier or for any non-designated carrier associated with the designated carrier is running.

[0079] Reference is now made to **Figure 5**. In **Figure 5**, designated carrier **200** with which the non-designated carrier **505** is associated, is similar to designated carrier **200** described above with reference to **Figures 2 to 4**.

[0080] With regard to non-designated carrier **505**, at a time illustrated by **510**, which corresponds with the time illustrated by reference numeral **120**, the active time for non-designated carrier **505** starts. Similarly, when drx-InactivityTimer **132** expires as shown by arrow **134**, the non-designated carrier **505** also proceeds to DRX, as shown by reference numeral **512**.

[0081] Subsequently, at the expiration of the short DRX cycle **150**, both designated carrier **200** and non-designated carrier **505** associated with the designated carrier **200** proceed to Active time, as shown at reference numeral **520**.

[0082] In the example of **Figure 5**, explicit signaling from the eNB to the UE, as provided by arrow **522**, causes the UE to disable reception on the non-designated carrier

505 and proceed to DRX. However, in one embodiment of **Figure 5**, the next Active time cycle on designated carrier **200** also causes the non-designated carrier **505** associated with the designated carrier **200** to proceed to Active time.

[0083] As indicated above, the Active time **136** may be extended based on a drx-RetransmissionTimer running on non-designated carrier **505**.

[0084] 5. Inherent activation, inactivity timer

[0085] In a further embodiment, similar to the embodiment described above with regard to **Figure 5**, at the start of the On Duration of the designated carrier, the UE enables carrier reception on a non-designated carrier associated with the designated carrier assigned by the eNB. In some embodiments carrier reception on multiple non-designated carriers associated with the designated carrier may be enabled.

[0086] In addition, a drx-InactivityTimer is maintained for the non-designated carrier. The drx-InactivityTimer is started when the carrier reception of the non-designated carrier is enabled at the start of the On Duration of the associated designated carrier. The drx-InactivityTimer is restarted whenever a new PDSCH packet is received on the non-designated carrier. A drx-RetransmissionTimer is also maintained during Active time of the non-designated carrier. The drx-RetransmissionTimer for an HARQ process is started at the earliest time when a retransmission may be expected for a previously transmitted packet on the corresponding HARQ process. The drx-RetransmissionTimer for an HARQ process is disabled when a packet is received correctly for the process or the maximum number of retransmissions has been reached.

[0087] The non-designated carrier remains in Active time when either the drx-InactivityTimer or the drx-RetransmissionTimer is running. At any time during the Active time on the non-designated carrier, the eNB can instruct the UE through signaling to disable carrier reception on the non-designated carrier.

[0088] In one embodiment, the designated carrier may delay moving from an Active time to DRX until all the inactivity timers and DRX retransmission timers have expired on the non-designated carrier(s) associated with the designated carrier.

[0089] Referring to **Figure 6**, designated carrier **200** with which the non-designated carrier **605** is associated, is similar to the designated carriers described above.

[0090] A non-designated carrier **605** is activated at the On Duration **122** of the associated designated carrier **200**. Specifically, as shown at reference numeral **610**, the Active time starts at the same time **120** as the associated designated carrier **200**.

[0091] The drx-InactivityTimer **622** for the non-designated carrier is restarted when the last new PDSCH packet is received on that non-designated carrier as shown by arrow **620**.

[0092] At the expiration of the drx-InactivityTimer **622**, the non-designated carrier **605** proceeds to a DRX period, as shown at reference numeral **630**.

[0093] Subsequently, as shown at reference numeral **640**, the non-designated carrier **605** proceeds to an Active time in conjunction with the expiration of the short DRX cycle **150** of the associated designated carrier **200**.

[0094] An explicit message **642** is received from the eNB, causing the non-designated carrier **605** to disable reception. However, in one embodiment, a subsequent On Duration at the associated designated carrier **200** causes the non-designated carrier **605** to proceed to an Active time.

[0095] A drx-RetransmissionTimer **624** may also be utilized to extend the Active time of non-designated carrier **605**.

[0096] 6. Specifying an On Duration timer for non-designated carriers

[0097] In a further embodiment, the eNB may signal an On Duration timer for a non-designated carrier to the UE through RRC signaling or MAC CE or other signaling methods. The OnDurationTimer is in addition to the drx-RetransmissionTimers.

[0098] Similar to the embodiment described with reference to **Figure 5** above, at the start of the On Duration on the associated designated carrier, the UE enables carrier reception on a non-designated carrier assigned by the eNB. The UE also starts the OnDurationTimer at this time.

[0099] drx-RetransmissionTimers are also maintained during the Active time of the non-designated carrier. The drx-RetransmissionTimer for an HARQ process is started at the earliest time when a retransmission may be expected for a previously transmitted packet on the corresponding HARQ process. The drx-RetransmissionTimer for an HARQ process is disabled when a packet is received correctly for this HARQ process or the maximum number of retransmissions has been reached.

[00100] The UE remains in Active time for the non-designated carrier when the OnDurationTimer is running and when the associated designated carrier is in Active time or when a drx-RetransmissionTimer is running for the non-designated carrier. In another embodiment, the UE remains in Active time for the non-designated carrier when the OnDurationTimer is running or when a drx-RetransmissionTimer is running, regardless of whether the associated designated carrier is in Active time or not. Furthermore, in one embodiment, the eNB may instruct the UE through signaling to disable carrier reception on the non-designated carrier anytime during the Active time of the non-designated carrier.

[00101] Referring to **Figure 7**, designated carrier **200** with which the non-designated carrier **705** is associated, is similar to the designated carrier **200** described above.

[00102] A non-designated carrier **705** follows the activation of the Active time of the associated designated carrier. Thus, as shown at reference numeral **710**, the non-designated carrier **705** proceeds to an active mode similar to that shown by reference numeral **120** for associated designated carrier **200**.

[00103] In the embodiment of **Figure 7**, the OnDurationTimer **720** expires at a time shown by reference numeral **722**. At this point, the UE disables reception on the non-designated carrier **705**.

[00104] Reception is enabled on non-designated carrier **705** at a time shown by reference numeral **730** which corresponds with the end of the short DRX cycle **150** when the associated designated carrier **200** proceeds back into an Active mode as shown by reference numeral **110**.

[00105] Subsequently, an explicit signal is received to disable the non-designated carrier **705**. The explicit signal is shown by arrow **732**, causing non-designated carrier **705** to disable reception.

[00106] Reference is made to **Figure 8**. In an alternative embodiment, the OnDurationTimer **820** in **Figure 8** is set to be for a relatively long period.

[00107] In the embodiment of **Figure 8**, the non-designated carrier **705** proceeds into an Active time at a time **710**. This corresponds with the activation of the associated designated carrier **200** to an Active time as shown by reference numeral **120**.

[00108] However, as opposed to the embodiment of **Figure 7**, the OnDurationTimer **820** does not expire in the embodiment of **Figure 8** prior to the associated designated carrier **200** proceeding back into a DRX mode at the end of Active time **136**. In this case, the UE disables reception on the non-designated carrier **705** at a time shown by reference numeral **822** corresponding with the end of the Active time **136** of the associated designated carrier **200**.

[00109] The remaining points of **Figure 8** correspond with those of **Figure 7**.

[00110] Thus, in accordance with the embodiments above, the OnDurationTimer may force the UE to disable reception on the non-designated carrier **705** prior to the Active time **136** of the associated designated carrier **200** expiring. Conversely, if the Active time **136** of the associated designated carrier **200** expires prior to the expiration of OnDurationTimer **820** of non-designated carrier **705**, this may cause the UE to disable reception on the non-designated carrier **705**.

[00111] 7. Signaling an OnDurationTimer and a drx-InactivityTimer

[00112] In a further embodiment, the eNB can signal an OnDurationTimer for the non-designated carrier to the UE through RRC signaling, a MAC CE or other signaling, in addition to the drx-RetransmissionTimer and the drx-InactivityTimer. Similar to **Figure 6** above, at the start of the On Duration on the associated designated carrier, the UE enables carrier reception on a non-designated carrier assigned by the eNB. The UE also starts the OnDurationTimer and the drx-InactivityTimer at this time.

[00113] The drx-InactivityTimer is restarted whenever a new PDSCH packet is received on the non-designated carrier. drx-RetransmissionTimers are also maintained during the Active time of the non-designated carrier. The drx-RetransmissionTimer for an HARQ process is started at the earliest time when retransmission may be expected for a previously transmitted packet on the corresponding HARQ process. The drx-RetransmissionTimer for an HARQ process is disabled when a packet is received correctly for the HARQ process or the maximum number of retransmissions has been reached.

[00114] The UE remains in Active time on the non-designated carrier when the OnDurationTimer is running and the associated designated carrier is in Active time, or the drx-Inactivity timer is running or a drx-RetransmissionTimer is running. In another embodiment, the UE remains in Active time for the non-designated carrier when the OnDurationTimer is running or the drx-Inactivity timer is running or a drx-RetransmissionTimer is running, regardless of whether the associated designated carrier is in Active time or not.

[00115] At any time during the Active time on the non-designated carrier, the eNB can instruct the UE through signaling to disable carrier reception on the non-designated carrier.

[00116] Reference is now made to **Figure 9**. In **Figure 9**, a designated carrier **200** with which the non-designated carrier **905** is associated, is similar to those as described above.

[00117] With regard to non-designated carrier **905**, an OnDurationTimer **912** value is signaled by the eNB to the UE, as well as a drx-InactivityTimer **922**.

[00118] With regard to **Figure 9**, in a similar manner to that described above with regard to **Figure 7**, the Active time **910** of non-designated carrier **905** may be the OnDurationTimer **912** value. In addition, the Active time **910** may be extended based on the drx-InactivityTimer **922**. When the last new PDSCH packet is received as shown by arrow **920** the drx-InactivityTimer restarts and continues running until a time, as shown by reference numeral **930**, the drx-InactivityTimer expires, at which point the non-designated carrier **905** proceeds to disable reception.

[00119] In other embodiments, a drx-RetransmissionTimer **924** may extend the Active time **910**.

[00120] The OnDurationTimer **912** is reset and the non-designated carrier **905** proceeds to an Active time at a time shown by reference numeral **940**, which corresponds with the end of the short DRX cycle **150** for the associated designated carrier **200**. Explicit signaling is provided to the UE to disable non-designated carrier **905**, as depicted by arrow **942**.

[00121] In other embodiments, the Active time **136** of **Figure 9** may be extended if the drx-InactivityTimer **922** or a drx-RetransmissionTimer **924** on non-designated carrier **905** is still running. Alternatively, the non-designated carrier **905** may be forced to disable reception at the end of Active time **136**, regardless of whether drx-InactivityTimer **922** or drx-RetransmissionTimer **924** has expired.

[00122] In a further alternative embodiment, the Active time **910** of non-designated carrier **905** may exceed the Active time **136** of the associated designated carrier **200**.

[00123] 8. drx-FollowDesignatedTimer

[00124] In a further embodiment, the eNB may signal a “drx-FollowDesignatedTimer” for the non-designated carrier to the UE through RRC signaling or a MAC CE, or other methods of communication. In addition, the drx-RetransmissionTimer may be signaled.

[00125] The drx-FollowDesignatedTimer value may be configured ‘statically’ such as through RRC signaling or dynamically through a MAC CE. During the Active time on the designated carrier, the eNB may instruct the UE, through signaling, to enable carrier reception on the non-designated carrier associated with the designated carrier at a specific action time. For the case of dynamic configuration of the drx-FollowDesignatedTimer, the signaling to enable the carrier reception of the non-designated carrier includes the drx-FollowDesignatedTimer value. At the action time, the UE starts the drx-FollowDesignatedTimer.

[00126] drx-RetransmissionTimers are also maintained during the Active time of the non-designated carrier. The drx-RetransmissionTimer for an HARQ process is started at the earliest time when a retransmission may be expected for a previously transmitted

packet on the corresponding HARQ process. The drx-RetransmissionTimer for an HARQ process is disabled when a packet is received correctly for the HARQ process or maximum number of retransmissions has been reached. When the drx-FollowDesignatedTimer is running, the UE only remains in Active time on the non-designated carrier when the associated designated carrier is in Active time or when a drx-Retransmission Timer is running. When the drx-FollowDesignatedTimer is expired, and if the drx-Retransmission Timer has also expired, the UE disables the carrier reception on the non-designated carrier regardless of the Active time of the associated designated carrier.

[00127] In one specific embodiment, the drx-FollowDesignatedTimer is of several Long DRX cycles or Short DRX cycles in duration. This means that the Active time of the non-designated carrier will follow that of the associated designated carrier for several Long DRX cycles or Short DRX cycles and then carrier reception on the non-designated carrier will be disabled.

[00128] Reference is now made to **Figure 10**. In **Figure 10**, the designated carrier **200** with which the non-designated carrier **1005** is associated, is similar to that described above.

[00129] Explicit signaling **1008** provides the start for the non-designated carrier **1005**.

[00130] Non-designated carrier **1005** has a drx-FollowDesignatedTimer **1020** signaled to it. Such signaling may include a pre-configured value or may have a dynamic value as indicated above.

[00131] The non-designated carrier **1005** follows the associated designated carrier **200** during the time when the drx-FollowDesignatedTimer **1020** is Active. Thus, at the time shown by reference numeral **1010** the non-designated carrier **1005** proceeds to an Active mode and at a time shown by reference numeral **1022** the non-designated carrier **1005** proceeds to a DRX mode or where reception is disabled. This time shown by reference numeral **1022** corresponds with the expiration of the drx-InactivityTimer **132** on the associated designated carrier **200**.

[00132] Similarly, at the expiration of short DRX cycle **150** in the example of **Figure 10**, the non-designated carrier **1005** proceeds back to an Active time, as shown at reference numeral **1030**.

[00133] At the expiration of the drx-FollowDesignatedTimer **1020**, the non-designated carrier **1005** disables reception until further explicit signaling is received.

[00134] In some embodiments, the drx-FollowDesignatedTimer **1020** may be used in conjunction with a drx-InactivityTimer.

[00135] The LTE Rel 8 specification, such as 3GPP TS 36.321 may be supplemented to account for the embodiments described above. Examples of such specification additions for the designated carrier may be:

When a DRX cycle is configured on the designated carrier, the Active Time includes the time while:

- *onDurationTimer_{DC}* or *drx-InactivityTimer_{DC}* or *drx-RetransmissionTimer_{DC}* or *mac-ContentionResolutionTimer_{DC}* (as described in subclause 5.1.5) is running; or
- a Scheduling Request sent on PUCCH of any UL carrier assigned to the UE is pending (as described in subclause 5.4.4); or
- an uplink grant / DL ACK/NAK on PHICH for a pending HARQ retransmission on any UL carrier assigned to the UE [or a UL carrier whose grant/DL ACK/NAK on PHICH may appear on the DL designated carrier] can occur and there is data in the corresponding HARQ buffer; or
- a PDCCH indicating a new transmission addressed to the C-RNTI of the UE has not been received after successful reception of a Random Access Response for the explicitly signaled preamble (as described in subclause 5.1.4); or
- *drx-InactivityTimer_i* or *drx-RetransmissionTimer_i* is running on at least one of the DL non-designated carriers associated with the designated carrier; or an uplink grant/DL ACK/NAK on PHICH for a pending HARQ retransmission on a UL carrier, whose grant may appear on any of the DL non-designated carriers associated with the designated carrier, can occur and there is data in the corresponding HARQ buffer.

When DRX is configured on the designated carrier, the UE shall for each subframe:

- If the Short DRX Cycle is used and $[(SFN * 10) + \text{subframe number}] \bmod (shortDRX-Cycle_{DC}) = (drxStartOffset_{DC}) \bmod (shortDRX-Cycle_{DC})$; or
- if the Long DRX Cycle is used and $[(SFN * 10) + \text{subframe number}] \bmod (LongDRX-Cycle_{DC}) = drxStartOffset_{DC}$:
 - start *onDurationTimer_{DC}*.
- if a HARQ RTT Timer expires in this subframe and the data in the soft buffer of the corresponding HARQ process was not successfully decoded:
 - start the *drx-RetransmissionTimer_{DC}* for the corresponding HARQ process.

- if a DRX Command MAC control element is received:
 - stop *onDurationTimer_{DC}*;
 - stop *drx-InactivityTimer_{DC}*.
- if *drx-InactivityTimer_{DC}* expires or a DRX Command MAC control element is received in this subframe:
 - if the short DRX cycle is configured:
 - start or restart *drxShortCycleTimer_{DC}*;
 - use the Short DRX Cycle_{DC}.
 - else:
 - use the Long DRX cycle_{DC}.
- if *drxShortCycleTimer_{DC}* expires in this subframe:
 - use the long DRX cycle_{DC}.
- during the Active Time, for a PDCCH-subframe except if the subframe is required for uplink transmission for half-duplex FDD UE operation and except if the subframe is part of a configured measurement gap:
 - monitor the PDCCH;
 - if the PDCCH indicates a DL transmission or if a DL assignment has been configured for this subframe:
 - start the HARQ RTT Timer for the corresponding HARQ process;
 - stop the *drx-RetransmissionTimer_{DC}* for the corresponding HARQ process.
 - if the PDCCH indicates a new transmission (DL or UL):
 - start or restart *drx-InactivityTimer_{DC}*.
- when not in Active Time, CQI/PMI/RI on PUCCH and SRS shall not be reported.

Regardless of whether the UE is monitoring PDCCH or not the UE receives and transmits HARQ feedback when such is expected.

NOTE: A UE may optionally choose to not send CQI/PMI/RI reports on PUCCH and/or SRS transmissions for up to 4 subframes following a PDCCH indicating a new transmission (UL or DL) received in the last subframe of active time. The choice not to send CQI/PMI/RI reports on PUCCH and/or SRS transmissions is not applicable for subframes where *onDurationTimer* is running.

[00136] For the non-designated carrier, building on the embodiments above, for each of the M non-designated carriers, where M is defined as above, the carrier reception on that carrier can be enabled implicitly at the start of the On Duration of the designated carrier with which the non-designated carrier is associated, i.e. mode 1; or can be enabled explicitly during the Active time of the associated designated carrier,

through explicit eNB signaling to the UE, i.e., mode 2. These two modes can be configured and signaled (e.g. through RRC signaling) by the eNB to the UE for each of the M non-designated carriers. In mode 2, during the Active time on the designated carrier, the eNB may instruct the UE to enable carrier reception on another non-designated component carrier (e.g. carrier i) associated with the designated carrier, through control signaling (e.g. RRC signaling, PDCCH, or MAC control element) sent on the designated carrier or one of the other N component carriers, where N is defined above.

[00137] The action time to enable the carrier reception on the component carrier can be implicit (e.g. x subframes after receiving the corresponding signaling from the eNB) or explicitly indicated in the signaling message. The signaling message may also indicate to the UE whether to maintain the *drx-InactivityTimer_i* during Active time. If *drx-FollowDesignatedTimer_i* is configured for a non-designated carrier, the initial enabling of the non-designated carrier is using mode 2, i.e. through explicit signaling from the eNB during the Active time of the associated designated carrier. The *drx-FollowDesignatedTimer* is started at the action time. During the time when *drx-FollowDesignatedTimer* is running, the non-designated carrier is subsequently enabled using mode 1, i.e. at the start of the On Duration of the associated designated carrier.

[00138] When the carrier reception on carrier i is enabled either at the start of the On Duration of the associated designated carrier for mode 1 or at the action time for mode 2, UE starts the *drx-InactivityTimer_i* if *drx-InactivityTimer_i* is configured and the UE is instructed by the eNB to maintain the *drx-InactivityTimer_i* during Active time on carrier i . Otherwise, the UE initializes the *activeFlag_i* and sets it to 1. For mode 1, the UE also starts the *onDurationTimer_i* if *onDurationTimer_i* is configured by the eNB. For mode 2, the UE starts the *drx-FollowDesignatedTimer_i* at the action time, if *drx-FollowDesignatedTimer_i* is configured by the eNB.

[00139] The specification addition for a non-designated carrier may include:

When a DRX cycle is configured on a non-designated carrier i , the Active Time on carrier i includes the time while:

- *drx-RetransmissionTimer_i* is running; or
 - *drx-InactivityTimer_i* is running; or
 - the *activeFlag_i* is set to 1, and the associated designated carrier is in Active time;
- or

- *onDurationTimer_i* is running and the associated designated carrier is in Active time; or
- *drx-FollowDesignatedTimer_i* is running and the associated designated carrier is in Active time; or
- an uplink grant/DL ACK/NAK on PHICH for a pending HARQ retransmission on a UL carrier, whose grant may appear on carrier *i*, can occur and there is data in the corresponding HARQ buffer

When DRX is configured on a non-designated carrier *i*, the UE shall for each subframe:

- if a HARQ RTT Timer expires in this subframe and the data in the soft buffer of the corresponding HARQ process was not successfully decoded:
 - start the *drx-RetransmissionTimer_i* for the corresponding HARQ process.
- if a signaling from the eNB (e.g. RRC signaling or MAC control element) is received indicating disabling the carrier reception on the component carrier *i*,
 - stop *drx-InactivityTimer_i*; if *drx-InactivityTimer_i* is configured, stop *onDurationTimer_i*; if *onDurationTimer_i* is configured, stop *drx-RetransmissionTimer_i*; set *activeFlag_i* to 0 if *activeFlag_i* is initialized, stop *drx-FollowDesignatedTimer_i*; if *drx-FollowDesignatedTimer_i* is configured, at the action time indicated in the signaling. The action time to disable the carrier reception on the component carrier *i* can be implicit (e.g. *y* subframes after receiving the corresponding signaling from the eNB) or explicitly indicated in the signaling message.
- during the Active Time, except if the subframe is required for uplink transmission for half-duplex FDD UE operation and except if the subframe is part of a configured measurement gap:
 - enable carrier reception on the component carrier *i*;
 - if a DL transmission or if a DL assignment has been configured for this subframe:
 - start the HARQ RTT Timer for the corresponding HARQ process;
 - stop the *drx-RetransmissionTimer_i* for the corresponding HARQ process.
 - if a new transmission is received:
 - start or restart *drx-InactivityTimer_i*.
- if *drx-FollowDesignatedTimer_i* expires, set *activeFlag_i* to 0 if *activeFlag_i* is initialized
- when not in Active Time, CQI/PMI/RI on PUCCH and SRS shall not be reported on carrier *i*.
- when not in Active Time, *onDurationTimer_i* shall be disabled if it has not expired.

[00140] Short And Long DRX Cycles On Both The Designated And Non-Designated Carriers

[00141] In another embodiment, a full set of DRX parameters may be configured for both the designated carrier(s) and the non-designated carrier(s). Intelligent scheduling at the eNB could enable the potential for efficient use of the Short and Long DRX cycles on both the designated and non-designated carriers.

[00142] When the Short DRX cycle is also configured, a UE essentially operates in the Short DRX cycle if it has recently received resource allocations for new data (only new data, not HARQ retransmissions). After a certain period of time with no new data resource allocations having been received, the UE switches to the Long DRX cycle after *drxShortCycleTimer* has expired. The UE continues to use the Long DRX cycle until another new data resource allocation is received on the PDCCH.

[00143] If each non-designated carrier was configured to operate with both the Short and Long DRX cycles, then the UE would be able to adapt to bursty traffic scenarios without the need for any explicit signalling. A UE receiving a large amount of data would have all of its carriers (both designated and non-designated) operating with the Short DRX cycles. If the volume of data decreased, an intelligent eNB would schedule all of the data for the UE only on the designated carrier(s). This would cause the designated carrier(s) to continue to operate with the Short DRX cycle, while the non-designated carriers would automatically switch to using the Long DRX cycle after *drxShortCycleTimer* has expired (since they would not be receiving any new data resource allocations). If the traffic activity for the UE then increased, the non-designated carriers would again start being used by the eNB during the On Duration and these non-designated carriers would automatically switch back to the Short DRX cycle mode. The boundaries of the Short DRX cycle and Long DRX cycle of a non-designated carrier may align with those of the associated designated carrier(s).

[00144] A further extension of the above is that a carrier that had not been used in a certain period of time (e.g. a configured multiple of the Long DRX cycle length) would be automatically (implicitly) deactivated by the UE and would need to be re-enabled by the eNB before being used.

[00145] In a further embodiment, the implicit activation of a carrier at the UE is possible. If a resource assignment for a currently-disabled carrier was received by the UE on the associated PDCCH, then that carrier should be immediately reactivated. As

would be appreciated, the resource assignment that caused the implicit activation could not be processed, but any future resource assignments on the carrier in question would be able to be processed.

[00146] Reference is now made to **Figure 11**. In **Figure 11**, an designated carrier **200** operates as described above.

[00147] A non-designated carrier **1105** is configured independently with a short DRX cycle **1150** and a long DRX cycle **1152**. At the start of data exchange, non-designated carrier **1105** is configured to utilise the short DRX cycle. Thus, as illustrated in **Figure 11** non-designated carrier **1105** follows designated carrier **200** for the active time.

[00148] If no data is received on the non-designated carrier **1105** for the short DRX cycle **1150** duration, the non-designated carrier switches to a long DRX cycle **1152** as illustrated in **Figure 11**. In the example of **Figure 11**, long DRX cycle **1152** is twice as long as short DRX cycle **1150**. However, this is not meant to be limiting since the Long DRX cycle can be any multiple of the Short DRX cycle.

[00149] SIGNALING

[00150] Signaling DRX parameters

[00151] As described above, the eNB may configure DRX parameters for the designated carrier(s) and DRX parameters for a set of M non-designated carriers for a UE. For each of the M non-designated carriers, the set of DRX parameters includes *drx-RetransmissionTimer*, may include *drx-InactivityTimer*, may include *onDurationTimer* and may include *drx-FollowDesignatedTimer*. For each of the M non-designated carriers, the eNB may configure the designated carrier associated with the non-designated carrier. For each of the M non-designated carriers, the eNB may indicate whether the UE should enable carrier reception on that carrier at the start of the On Duration of the associated designated carrier, or enable the carrier reception on that carrier only if explicit activation signaling is received from the eNB.

[00152] In one embodiment, the values of *drx-InactivityTimer* (if included), *onDurationTimer* (if included), *drx-RetransmissionTimer* are the same across all the

component carriers. In this case, the RRC signaling used to configure the DRX functionality does not need to include the *drx-InactivityTimer*, *onDurationTimer* and *drx-RetransmissionTimer* fields for each of the component carriers. The values of the full set of DRX parameters can be included in the RRC signaling for one of the designated carriers, while the values of the DRX parameters of other designated carriers, and the *drx-InactivityTimer* (if included), *onDurationTimer* (if included) and *drx-RetransmissionTimer* of other *M* non-designated component carriers are the same as those of the designated carrier. The RRC signaling also includes the *drx-FollowDesignatedTimer* for those non-designated carriers where the *drx-FollowDesignatedTimer* is configured.

[00153] In another embodiment, the values of the DRX parameters for different designated carriers are different. The values of *drx-InactivityTimer* (if included), *onDurationTimer* (if included), *drx-RetransmissionTimer* of a non-designated component carrier are the same as those of the associated designated carrier. In this case, the RRC signaling includes the full set of DRX parameters for each of the designated carriers. The *drx-InactivityTimer* (if included), *onDurationTimer* (if included) and *drx-RetransmissionTimer* values for each of the *M* non-designated component carriers are the same as those of its associated designated carrier.

[00154] In another embodiment, the values of *drx-InactivityTimer* (if included), *onDurationTimer* (if included), *drx-RetransmissionTimer*, and *drx-FollowDesignatedTimer* (if included for the non-designated carrier) are different for the different component carriers. In this case, the RRC signaling includes a full set of DRX parameters for the designated carrier(s), and a reduced set of DRX parameters, i.e., *drx-InactivityTimer* (if included), *onDurationTimer* (if included), *drx-RetransmissionTimer*, and *drx-FollowDesignatedTimer* (if included for the non-designated carrier) for each of the *M* other component carriers.

[00155] In yet another embodiment, the values of *drx-InactivityTimer* (if included), *onDurationTimer* (if included) and *drx-RetransmissionTimer* of some of the component carriers are the same as those of their associated designated carriers while the values of *drx-InactivityTimer* (if included), *onDurationTimer* (if included) and *drx-RetransmissionTimer* of some other component carriers are different than those of their designated carriers. In this case, the RRC signaling includes a full set of DRX parameters for the designated carriers, a reduced set of DRX parameters, i.e., *drx-*

InactivityTimer (if included), *onDurationTimer* (if included) and *drx-RetransmissionTimer* for some of the *M* component carriers, and *drx-FollowDesignatedTimer* for some of the *M* component carriers where *drx-FollowDesignatedTimer* is configured.

[00156] In yet another embodiment, the DRX parameters of all the non-designated carriers are configured to be the same values. In this case, the RRC signaling includes a full set of DRX parameters for the designated carrier(s) and a reduced set of DRX parameters, i.e., *drx-InactivityTimer* (if included), *onDurationTimer* (if included), *drx-RetransmissionTimer*, and *drx-FollowDesignatedTimer* (if included) for all the *M* other component carriers.

[00157] **Table 1** below shows an example of the fields included in the corresponding RRC signaling that support the different embodiments. The signaling fields and format shown are not meant to be limiting. It should be appreciated by those skilled in the art that other signaling fields and formats are also possible having regard to the present disclosure are also contemplated.

Fields	Definition
Number of DRX-configured designated carrier (D)	Number of designated carriers where DRX parameters are configured
For (i=0; i<D; i++) {	
Designated carrier index	Logical carrier index for the assigned designated carrier
onDurationTimer _{DC}	onDurationTimer of the designated carrier
drx-InactivityTimer _{DC}	drx-InactivityTimer of the designated carrier
drx-RetransmissionTimer _{DC}	drx-RetransmissionTimer of the designated carrier
longDRX-CycleStartOffset _{DC}	longDRX-Cycle and drxStartOffset of the designated carrier
shortDRX-Cycle _{DC}	shortDRX-Cycle of the designated carrier (optional)
drxShortCycleTimer _{DC}	drxShortCycleTimer of the designated carrier (optional)
}	
Number of DRX-configured non-designated carriers (M)	Number of non-designated carriers where DRX parameters are configured
for (i=0; i<M; i++) {	
Associated designated carrier	Logical/physical carrier index of the designated carrier with which this non-designated carrier is associated

Implicit/explicit start of Active time	A flag to indicate whether the start of the Active time on the non-designated carrier <i>i</i> , is aligned to the On Duration of the associated designated carrier (i.e. implicit); or the start of the Active time on the non-designated carrier <i>i</i> is explicitly signalled by the eNB during the Active time of the associated designated carrier.
drx-InactivityTimer _{<i>i</i>} _configured	A flag to indicate whether drx-InactivityTimer for carrier <i>i</i> is configured. Set to 1 to indicate that it is configured. Set to 0 to indicate that it is not configured.
If (drx-InactivityTimer _{<i>i</i>} _configured == 1) {	
drx-InactivityTimer _{<i>i</i>} _value_included	A flag to indicate whether the value of drx-InactivityTimer for carrier <i>i</i> is included. Set to 1 to indicate the value is included. Set to 0 to indicate the value is not included and it is the same as that of the associated designated carrier.
If (drx-InactivityTimer _{<i>i</i>} _value_included == 1) {	
drx-InactivityTimer _{<i>i</i>}	Value of drx-InactivityTimer _{<i>i</i>}
}	
}	
drx-RetransmissionTimer _{<i>i</i>} _value_included	A flag to indicate whether the value of drx-RetransmissionTimer for carrier <i>i</i> is included. Set to 1 to indicate the value is included. Set to 0 to indicate the value is not included since it is the same as that of the associated designated carrier.
If (drx-RetransmissionTimer _{<i>i</i>} _value_included == 1) {	
drx-RetransmissionTimer _{<i>i</i>}	Value of drx-RetransmissionTimer _{<i>i</i>}
}	
onDurationTimer _{<i>i</i>} _configured	A flag to indicate whether onDurationTimer for carrier <i>i</i> is configured. Set to 1 to indicate that it is configured. Set to 0 to indicate that it is not configured.
If (onDurationTimer _{<i>i</i>} _configured == 1) {	
onDurationTimer _{<i>i</i>} _value_included	A flag to indicate whether the value of onDurationTimer for carrier <i>i</i> is included. Set to 1 to indicate the value is included. Set to 0 to indicate the value is not included since it is the same as that of the associated designated carrier.
If (onDurationTimer _{<i>i</i>} _value_included == 1) {	
onDurationTimer _{<i>i</i>}	Value of onDurationTimer _{<i>i</i>}
}	
}	
}	

drx-FollowDesignatedTimer _i _configured	A flag to indicate whether drx-FollowDesignatedTimer for carrier <i>i</i> is configured. Set to 1 to indicate that it is configured. Set to 0 to indicate that it is not configured.
{ If (drx-FollowDesignatedTimer _i _configured == 1)	
drx-FollowDesignatedTimer _i	Value of drx-FollowDesignatedTimer _i
}	
}	

Table1 An example of DRX parameters included in the RRC signalling

[00158] Signaling from the eNB to the UE to enable/disable carrier reception

[00159] The eNB can instruct the UE to enable or disable carrier reception on a component carrier, through RRC signaling or MAC CE or even via certain Downlink Control Information (DCI) formats on PDCCH (i.e., Layer 1 signaling). The RRC signaling or MAC CE or PDDCH can be sent on a designated carrier only or on any of the *N* component carriers, where *N* is defined above. In the signaling message sent in RRC signaling, MAC CE or PDCCH to enable carrier reception on a component carrier, a field may be included to indicate whether the component carrier is a designated carrier or a non-designated carrier.

[00160] Reference is now made to **Figure 12**. **Figure 12** shows an example of the 'carrier reception enable/disable command MAC control element' **1200** sent by the eNB to the UE to enable/disable the carrier reception on a carrier, with explicit action time. The new MAC control element **1200** can use one of the reserved DL LCID (logical channel ID) values for DL-SCH (downlink shared channel) shown in Table 6.2.1-1 of 3GPP TS 36.321. 'DS' **1205** is a one-bit field to indicate if the carrier is a designated or a non-designated carrier. 'E/D' **1210** is a one-bit field to indicate if the command is to enable or disable the carrier reception. 'Carrier Index' **1220** is the physical or logical carrier index of the carrier on which the carrier reception should be enabled/disabled. If the 'E/D' **1210** is set to disable carrier reception, the value of 'DS' **1205** can be set to a pre-defined value and is ignored by the UE. Another embodiment is that only the carrier over which the "carrier reception enable/disable command MAC control element" **1200** is sent will be impacted by this command. For example, if a MAC CE disabling the carrier reception is received on carrier #3, then carrier #3 will disable carrier reception. The action time for when the carrier reception on the carrier should be enabled/disabled is

defined by the next radio frame with the 4 least significant bits (LSB) of system frame number (SFN) equal to 'Action time (LSB of SFN)' **1230**, and the subframe within this radio frame with the subframe number equals to 'Action time (subframe offset)' **1240**.

[00161] Another alternative for the action time is to define a relative time offset. Those skilled in the art will appreciate that in some cases there may be some difficulty determining a fixed reference timing for the relative time offset since the MAC CE transmission may involve HARQ retransmissions. One possible way to establish the fixed reference time is that when the HARQ ACK is received on the UL, the eNB can derive that the UE receives the corresponding MAC CE 4ms earlier, since the HARQ feedback transmission is, in one embodiment, 4ms after the corresponding transport block reception.

[00162] The 4 LSB of SFN allows up to 16 radio frames or 160ms of HARQ retransmission attempts for the MAC CE to be successfully received at the UE and acknowledged back to the eNB. A MAC ACK CE (called 'carrier reception enable/disable ACK MAC control element') is defined in the uplink (UL) for the UE to acknowledge reception of the 'carrier reception enable/disable command MAC control element'. The explicit acknowledgement protocol allows the eNB to confirm that the UE has successfully received the 'carrier reception enable/disable command MAC control element' **1200** before sending PDSCH data to the UE on the assigned carrier.

[00163] In general, control signaling is only acknowledged at the RRC level. However, this particular MAC control signaling has a potentially long-term consequence and is therefore of sufficient importance to have some form of acknowledgement. RRC signaling is possible, but in some embodiments may be too slow for the desired purpose or may incur too much overhead as compared to the MAC level signaling, proposed herein.

[00164] A further alternative solution to acknowledge reception of the 'carrier reception enable/disable command MAC control element' **1200** is to use the HARQ feedback. When the transport block containing the MAC CE is transmitted to the UE, the eNB will monitor the corresponding UL HARQ feedback. When the corresponding HARQ ACK is received in the UL, the eNB considers that the 'carrier reception enable/disable command MAC control element' **1200** has been successfully received by the UE.

[00165] Reference is now made to **Figure 13**, which shows an example of the 'carrier reception enable/disable ACK MAC control element' **1300**. 'Carrier Index' **1310** is the physical or logical carrier index of the carrier on which the carrier reception enabled/disabled command is acknowledged. This new MAC CE **1300** can use one of the reserved UL LCID values for UL-SCH shown in Table 6.2.1-2 of 3GPP TS 36.321.

[00166] Reference is now made to **Figure 14**, which provides another example format for a MAC control element used to enable or disable carrier reception on a carrier. Here, binary flags **1410**, **1412**, **1414** and **1416** are used to selectively enable or disable up to the maximum of four carriers. The fields **1411**, **1413**, **1415**, **1417** are used to indicate whether each of the carriers indicated in **1410**, **1412**, **1414**, **1416** respectively, is a designated carrier or a non-designated carrier. If a CI field is set to disable carrier reception, the corresponding value of DS field can be set to a predefined value and is ignored by the UE.

[00167] As will be appreciated, in one embodiment having a designated carrier and four non-designated carriers, the five carriers may be aggregated with one UE. One carrier is the designated carrier which is currently in Active time, leaving the four non-designated carriers for binary flags **1410**, **1412**, **1414**, and **1416**. Further, in one embodiment, the Carrier Indices for any non-allocated carriers would simply be treated as reserved or padding bits.

[00168] For example, a value for binary flag **1410** of 0 would indicate that the corresponding non-designated carrier shall be disabled, while a value of 1 would indicate that the corresponding non-designated carrier shall be enabled. Similarly, binary flags **1412**, **1414** and **1416** could be set. Any carriers that were to continue in their present state would simply have their corresponding binary flags set to the same value as before. For instance, if carriers 1 and 2, were currently enabled and carriers 3 and 4 were currently disabled, a binary value of 00001010 for the first byte **1420** of the MAC control element would instruct the UE to (a) keep carrier 1 enabled, (b) disable carrier 2, (c) enable carrier 3, and (d) keep carrier 4 disabled. The action time fields are signaled in the same manner as described above.

[00169] **Figure 15** contains the corresponding example format of an acknowledgement MAC CE **1500** that would acknowledge reception by the UE of the carrier enable/disable MAC control element shown in **Figure 14**. The values of binary flags **1510**, **1512**, **1514** and **1516**, corresponding to Cl_1 , Cl_2 , Cl_3 , Cl_4 are set to the same as the corresponding binary flag values **1410**, **1412**, **1414**, and **1416** previously received in 'carrier reception enable/disable command MAC control element' **1400** of **Figure 14**.

[00170] An advantage of the MAC CE format of **Figures 14** and **15** is that multiple carriers can be simultaneously enabled and/or disabled by the same MAC CE, without the need for sending multiple MAC control elements (thereby representing additional signaling overhead) in order to achieve the same goal.

[00171] If the ability to enable and disable uplink carriers selectively is also desired, the MAC CE discussed above could be extended as shown by MAC control element **1600** in **Figure 16** to handle up to the maximum of four downlink carriers and four uplink carriers. The one-bit enable/disable field for each carrier would function in the same manner as previously discussed. In particular downlink carrier flags **1610**, **1612**, **1614** and **1616** control four downlink carriers and uplink carrier flags **1620**, **1622**, **1624** and **1626** control activation/deactivation of four uplink carriers.

[00172] **Figure 17** shows the corresponding MAC CE **1700** format for acknowledging reception by the UE of the carrier enable/disable MAC CE **1600** shown in **Figure 16**. Thus downlink carrier flags **1710**, **1712**, **1714** and **1716** correspond with downlink carrier flags **1610**, **1612**, **1614** and **1616** and uplink carrier flags **1720**, **1722**, **1724** and **1726** correspond with uplink carrier flags **1620**, **1622**, **1624** and **1626**.

[00173] As for the set of MAC CEs proposed in **Figures 14** and **15**, the contents of the acknowledgement control element in **Figure 17** would mirror the first payload byte of the enable/disable control element in **Figure 16**.

[00174] As will be appreciated, the above can be implemented on any UE. One exemplary UE is described below with reference to **Figure 18**. This is not meant to be limiting, but is provided for illustrative purposes.

[00175] **Figure 18** is a block diagram illustrating a UE capable of being used with embodiments of the apparatus and method of the present application. Mobile device

1800 is typically a two-way wireless communication device having voice or data communication capabilities. Depending on the exact functionality provided, the wireless device may be referred to as a data messaging device, a two-way pager, a wireless e-mail device, a cellular telephone with data messaging capabilities, a wireless Internet appliance, a mobile device, or a data communication device, as examples.

[00176] Where UE **1800** is enabled for two-way communication, it incorporates a communication subsystem **1811**, including both a receiver **1812** and a transmitter **1814**, as well as associated components such as one or more, generally embedded or internal, antenna elements **1816** and **1818**, local oscillators (LOs) **1813**, and a processing module such as a digital signal processor (DSP) **1820**. As will be apparent to those skilled in the field of communications, the particular design of the communication subsystem **1811** will be dependent upon the communication network in which the device is intended to operate.

[00177] Network access requirements will also vary depending upon the type of network **1819**. An LTE UE may require a subscriber identity module (SIM) card in order to operate on the LTE or LTE-A network. The SIM interface **1844** is normally similar to a card-slot into which a SIM card can be inserted and ejected like a diskette or PCMCIA card. The SIM card may hold key configuration **1851**, and other information **1853** such as identification, and subscriber related information.

[00178] When required network registration or activation procedures have been completed, UE **1800** may send and receive communication signals over the network **1819**. As illustrated in **Figure 18**, network **1819** can consist of multiple antennas communicating with the UE. These antennas are in turn connected to an eNB **1870**.

[00179] Signals received by antenna **1816** through communication network **1819** are input to receiver **1812**, which may perform such common receiver functions as signal amplification, frequency down conversion, filtering, channel selection and the like, and in the example system shown in **Figure 18**, analog to digital (A/D) conversion. A/D conversion of a received signal allows more complex communication functions such as demodulation and decoding to be performed in the DSP **1820**. In a similar manner, signals to be transmitted are processed, including modulation and encoding for example, by DSP **1820** and input to transmitter **1814** for digital to analog conversion, frequency up conversion, filtering, amplification and transmission over the communication network

1819 via antenna **1818**. DSP **1820** not only processes communication signals, but also provides for receiver and transmitter control. For example, the gains applied to communication signals in receiver **1812** and transmitter **1814** may be adaptively controlled through automatic gain control algorithms implemented in DSP **1820**.

[00180] UE **1800** typically includes a processor **1838** which controls the overall operation of the device. Communication functions, including data and voice communications, are performed through communication subsystem **1811**. Processor **1838** also interacts with further device subsystems such as the display **1822**, flash memory **1824**, random access memory (RAM) **1826**, auxiliary input/output (I/O) subsystems **1828**, serial port **1830**, one or more keyboards or keypads **1832**, speaker **1834**, microphone **1836**, other communication subsystem **1840** such as a short-range communications subsystem and any other device subsystems generally designated as **1842**. Serial port **1830** could include a USB port or other port known to those in the art.

[00181] Some of the subsystems shown in **Figure 18** perform communication-related functions, whereas other subsystems may provide “resident” or on-device functions. Notably, some subsystems, such as keyboard **1832** and display **1822**, for example, may be used for both communication-related functions, such as entering a text message for transmission over a communication network, and device-resident functions such as a calculator or task list.

[00182] Operating system software used by the processor **1838** is generally stored in a persistent store such as flash memory **1824**, which may instead be a read-only memory (ROM) or similar storage element (not shown). Those skilled in the art will appreciate that the operating system, specific device applications, or parts thereof, may be temporarily loaded into a volatile memory such as RAM **1826**. Received communication signals may also be stored in RAM **1826**.

[00183] As shown, flash memory **1824** can be segregated into different areas for both computer programs **1858** and program data storage **1850**, **1852**, **1854** and **1856**. These different storage types indicate that each program can allocate a portion of flash memory **1824** for their own data storage requirements. Processor **1838**, in addition to its operating system functions, may enable execution of software applications on the UE. A predetermined set of applications that control basic operations, including data and voice

communication applications for example, will normally be installed on UE **1800** during manufacturing. Other applications could be installed subsequently or dynamically.

[00184] One software application may be a personal information manager (PIM) application having the ability to organize and manage data items relating to the user of the UE such as, but not limited to, e-mail, calendar events, voice mails, appointments, and task items. Naturally, one or more memory stores would be available on the UE to facilitate storage of PIM data items. Such PIM application would generally have the ability to send and receive data items, via the wireless network **1819**. In one embodiment, the PIM data items are seamlessly integrated, synchronized and updated, via the wireless network **1819**, with the UE user's corresponding data items stored or associated with a host computer system. Further applications may also be loaded onto the UE **1800** through the network **1819**, an auxiliary I/O subsystem **1828**, serial port **1830**, short-range communications subsystem **1840** or any other suitable subsystem **1842**, and installed by a user in the RAM **1826** or a non-volatile store (not shown) for execution by the processor **1838**. Such flexibility in application installation increases the functionality of the device and may provide enhanced on-device functions, communication-related functions, or both. For example, secure communication applications may enable electronic commerce functions and other such financial transactions to be performed using the UE **1800**.

[00185] In a data communication mode, a received signal such as a text message or web page download will be processed by the communication subsystem **1811** and input to the processor **1838**, which may further process the received signal for element attributes for output to the display **1822**, or alternatively to an auxiliary I/O device **1828**.

[00186] A user of UE **1800** may also compose data items such as email messages for example, using the keyboard **1832**, which may be a complete alphanumeric keyboard or telephone-type keypad, as examples, in conjunction with the display **1822** and possibly an auxiliary I/O device **1828**. Such composed items may then be transmitted over a communication network through the communication subsystem **1811**.

[00187] For voice communications, overall operation of UE **1800** is similar, except that received signals would typically be output to a speaker **1834** and signals for transmission would be generated by a microphone **1836**. Alternative voice or audio I/O

subsystems, such as a voice message recording subsystem, may also be implemented on UE **1800**. Although voice or audio signal output may be accomplished primarily through the speaker **1834**, display **1822** may also be used to provide an indication of the identity of a calling party, the duration of a voice call, or other voice call related information for example.

[00188] Serial port **1830** in **Figure 18** would normally be implemented in a personal digital assistant (PDA)-type UE for which synchronization with a user's desktop computer (not shown) may be desirable, but is an optional device component. Such a port **1830** would enable a user to set preferences through an external device or software application and would extend the capabilities of UE **1800** by providing for information or software downloads to UE **1800** other than through a wireless communication network. The alternate download path may for example be used to load an encryption key onto the device through a direct and thus reliable and trusted connection to thereby enable secure device communication. As will be appreciated by those skilled in the art, serial port **1830** can further be used to connect the UE to a computer to act as a modem.

[00189] Other communications subsystems **1840**, such as a short-range communications subsystem, is a further component which may provide for communication between UE **1800** and different systems or devices, which need not necessarily be similar devices. For example, the subsystem **1840** may include an infrared device and associated circuits and components or a Bluetooth™ communication module to provide for communication with similarly enabled systems and devices. Subsystem **1840** may also be used for WiFi or WiMAX communications.

[00190] The processor **1838** and communications subsystem **1811** could be utilized to implement the procedures and features of **Figures 1 to 17**.

[00191] The embodiments described herein are examples of structures, systems or methods having elements corresponding to elements of the techniques of this application. This written description may enable those skilled in the art to make and use embodiments having alternative elements that likewise correspond to the elements of the techniques of this application. The intended scope of the techniques of this application thus includes other structures, systems or methods that do not differ from the techniques of this application as described herein, and further includes other structures,

systems or methods with insubstantial differences from the techniques of this application as described herein.

CLAIMS

1. A method for enabling or disabling a carrier for a user equipment in a wireless network, the method comprising:

receiving, by the user equipment, a carrier enable or disable command medium access control (MAC) control element over a downlink shared channel; and

transmitting, by the user equipment, an acknowledgment of the carrier enable or disable command MAC control element;

wherein the MAC control element comprises at least one of:

a plurality of bit fields corresponding with carrier identifiers, each of said plurality of bit fields designating whether a carrier corresponding with the carrier identifier of the bit field should be enabled or disabled;

an action time for when the carrier should be enabled or disabled; and

a subframe within the radio frame with a subframe number equal to an action time.

2. The method of claim 1, wherein the MAC control element comprises at least one of:

a single bit for designating whether to enable or disable a carrier;

a carrier index field to identify a carrier;

an action time for when the carrier should be enabled or disabled; or

a subframe within the radio frame with a subframe number equal to an action time.

3. The method of claim 1, wherein the acknowledgment comprises a carrier index corresponding with the carrier index field from the MAC control element.
4. The method of claim 1, wherein the acknowledgment comprises a plurality of bit fields corresponding with the plurality of bit fields in the MAC control element.
5. The method of claim 1, wherein the MAC control element comprises at least one of:
 - a plurality of bit fields corresponding with downlink and uplink carrier identifiers, each of said plurality of bit fields designating whether a downlink or an uplink carrier corresponding with the carrier identifier of the bit field should be enabled or disabled;
 - an action time for when the carrier should be enabled or disabled; and
 - a subframe within the radio frame with a subframe number equal to an action time.
6. The method of claim 5, wherein the acknowledgment comprises a plurality of bit fields corresponding with the plurality of bit fields in the MAC control element.
7. A user equipment comprising:
 - a communications subsystem,
 - wherein the communication subsystem is configured to perform the method of claim 1.
8. The method of claim 1, wherein transmitting the acknowledgment comprises using a hybrid automatic repeat request (HARQ) feedback.

9. The method of claim 1, wherein transmitting the acknowledgment comprises using a carrier enable or disable acknowledgment medium access control (MAC) control element (CE).

10. The method of claim 1, wherein receiving the carrier enable or disable command MAC control element comprises using a logical channel ID (LCID) value.

11. A method for enabling or disabling a carrier for a user equipment in a wireless network including an evolved node B (eNB), the method comprising:

transmitting, by the eNB, a carrier enable or disable command medium access control (MAC) control element over a downlink shared channel; and

receiving, by the eNB, an acknowledgment of the carrier enable or disable command MAC control element;

wherein the MAC control element includes at least one of:

a plurality of bit fields corresponding with carrier identifiers, each of said plurality of bit fields designating whether a carrier corresponding with the carrier identifier of the bit field should be enable or disabled;

an action time for when the carrier should be enabled or disabled;

and

a subframe within the radio frame with a subframe number equal to an action time.

12. The method of claim 11, wherein the carrier enable or disable command MAC control element includes a logical channel ID (LCID) value.

13. The method of claim 11, wherein receiving the acknowledgment comprises using a hybrid automatic repeat request (HARQ) feedback.

14. An apparatus for a wireless network, the apparatus comprising:

a communications subsystem,

wherein the communication subsystem is configured to perform the method of claim 11.

Research In Motion Limited

Patent Attorneys for the Applicant/Nominated Person

SPRUSON & FERGUSON

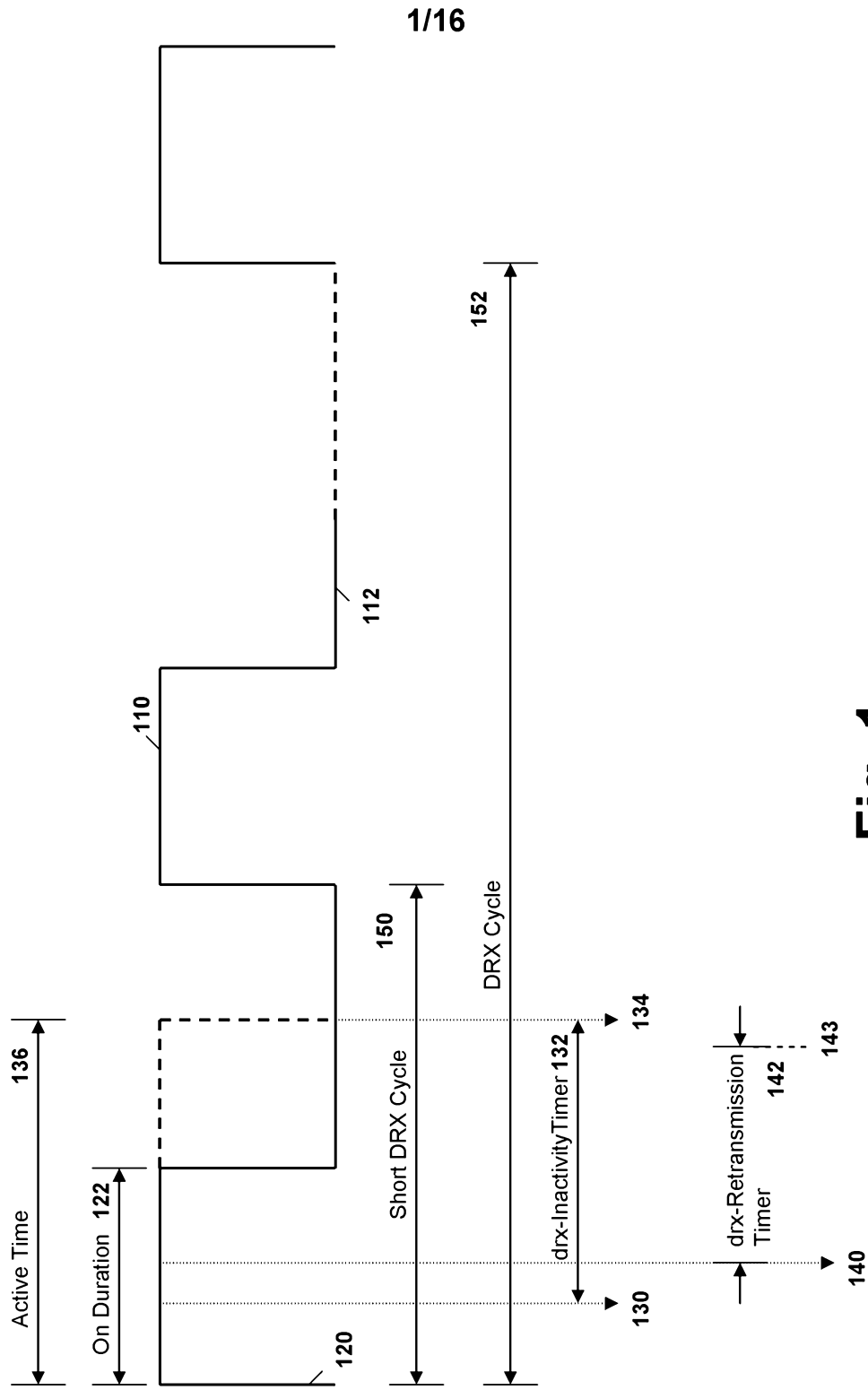

Fig. 1

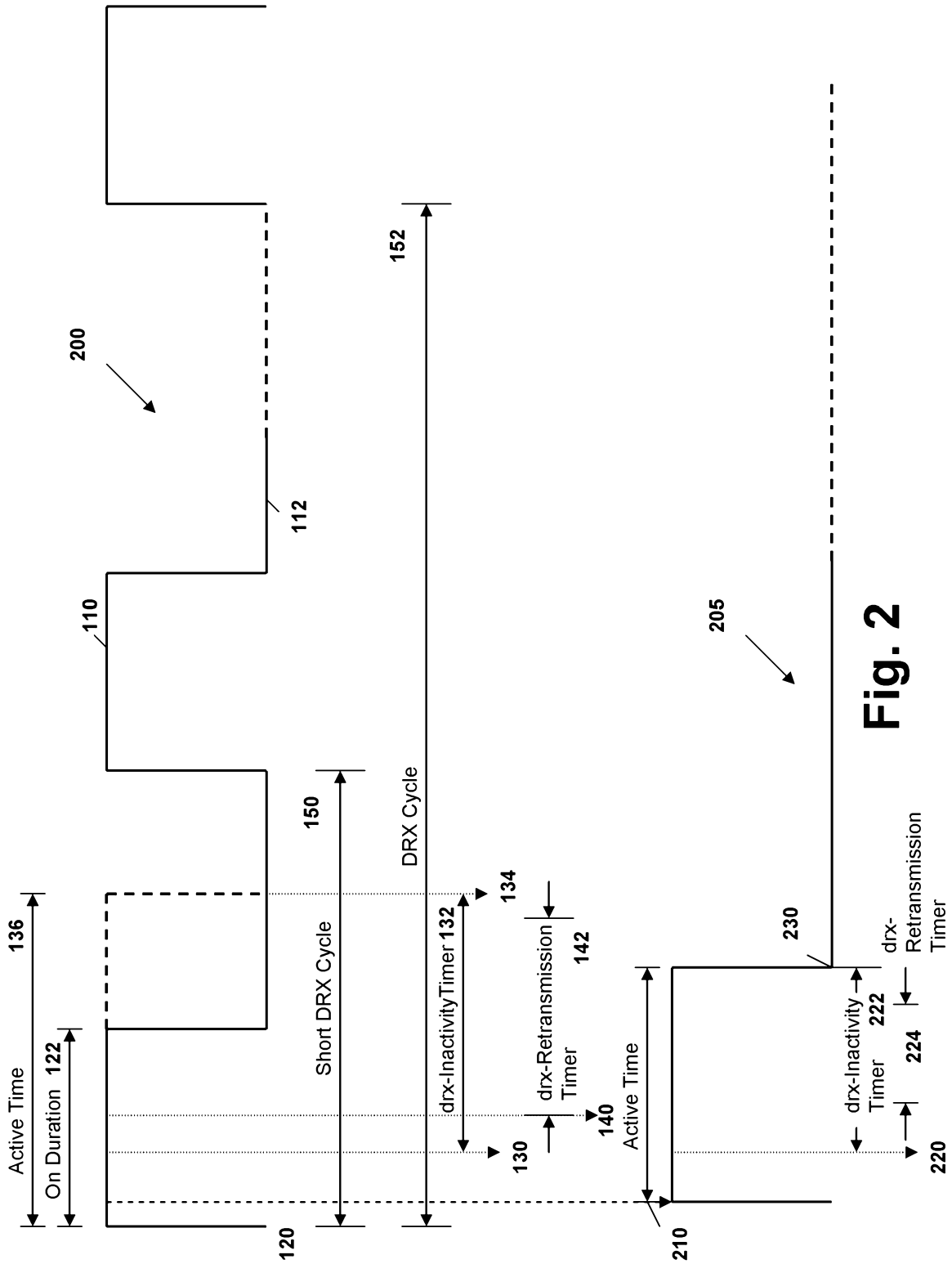

Fig. 2

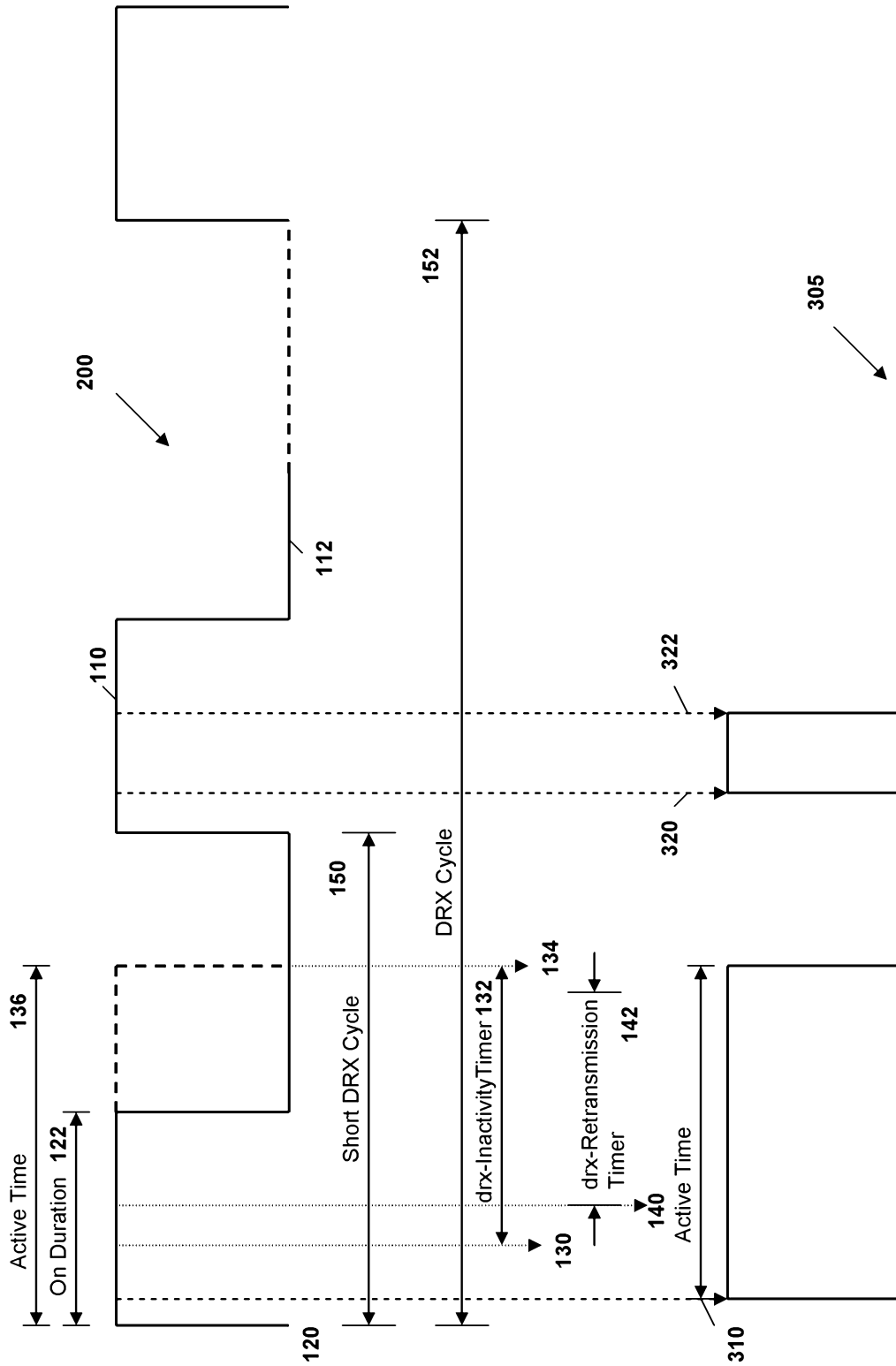

Fig. 3

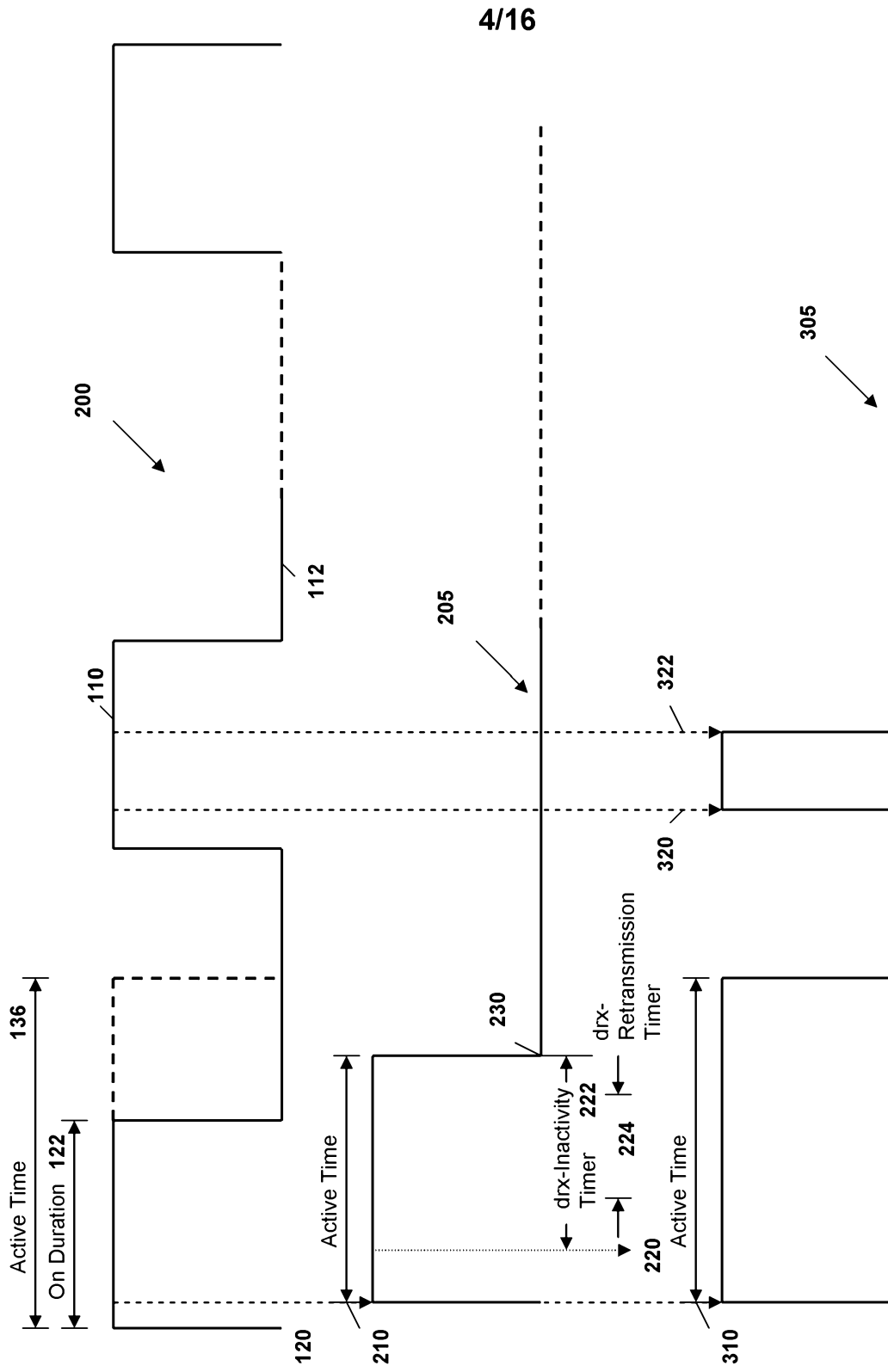

Fig. 4

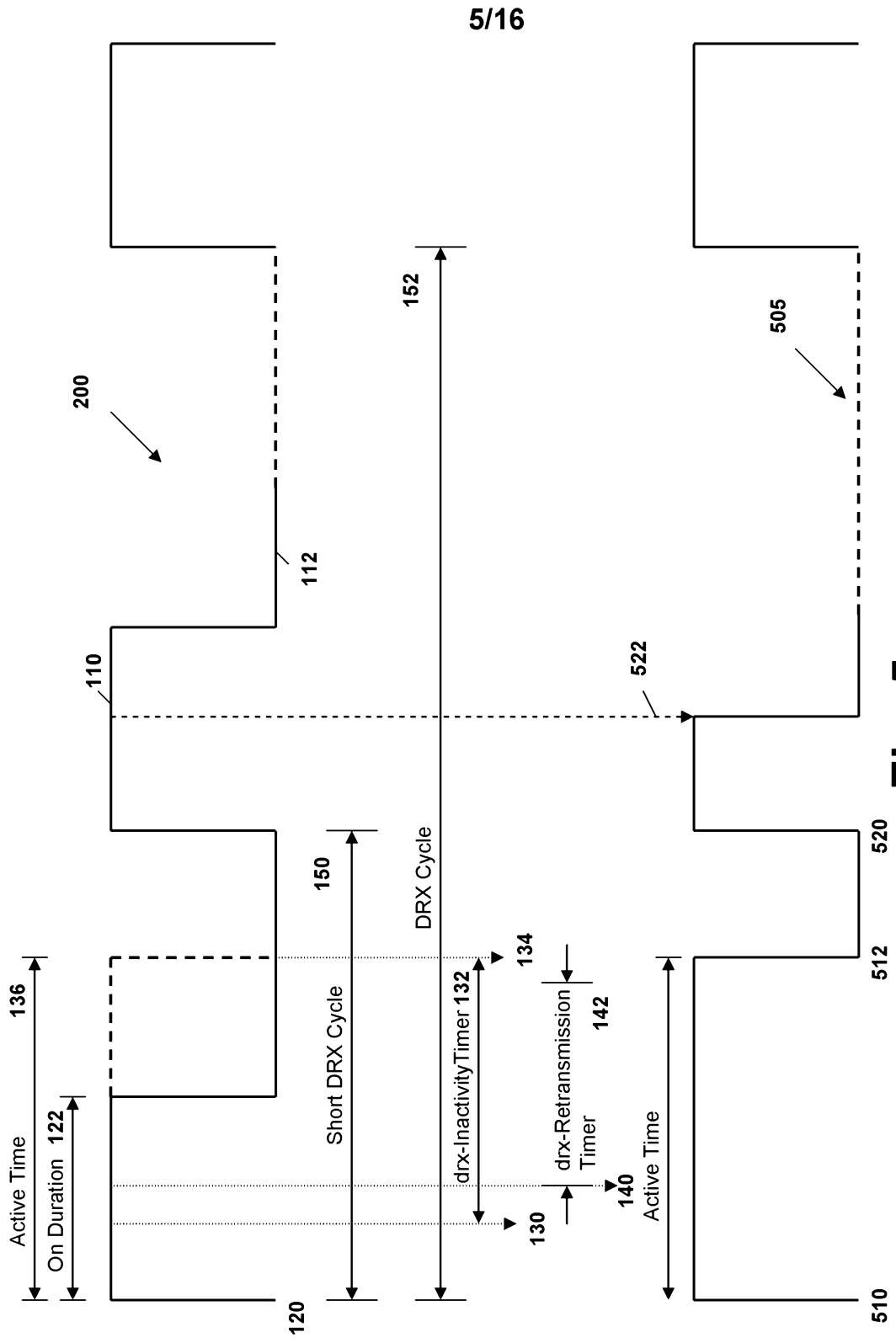
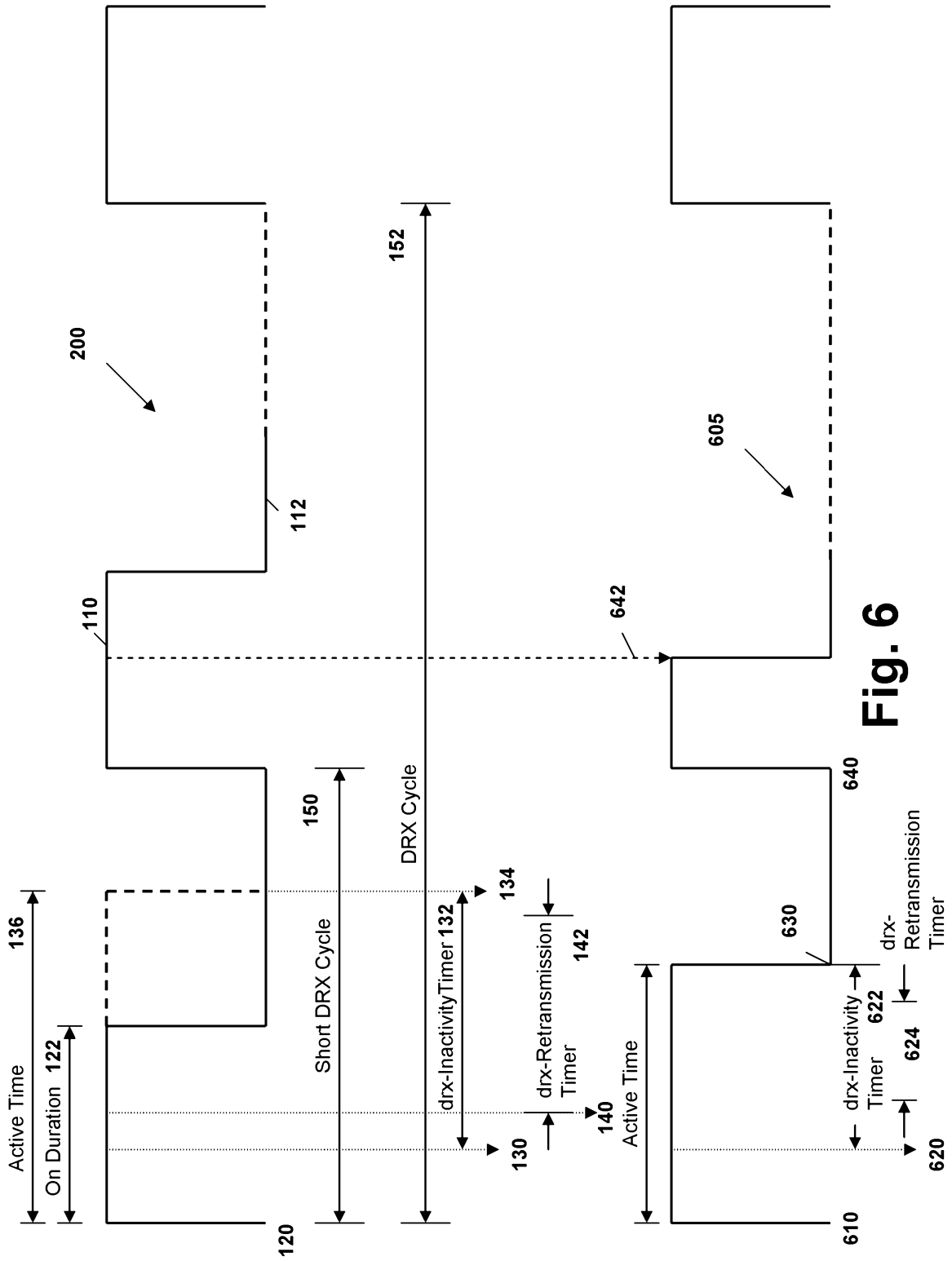

Fig. 5



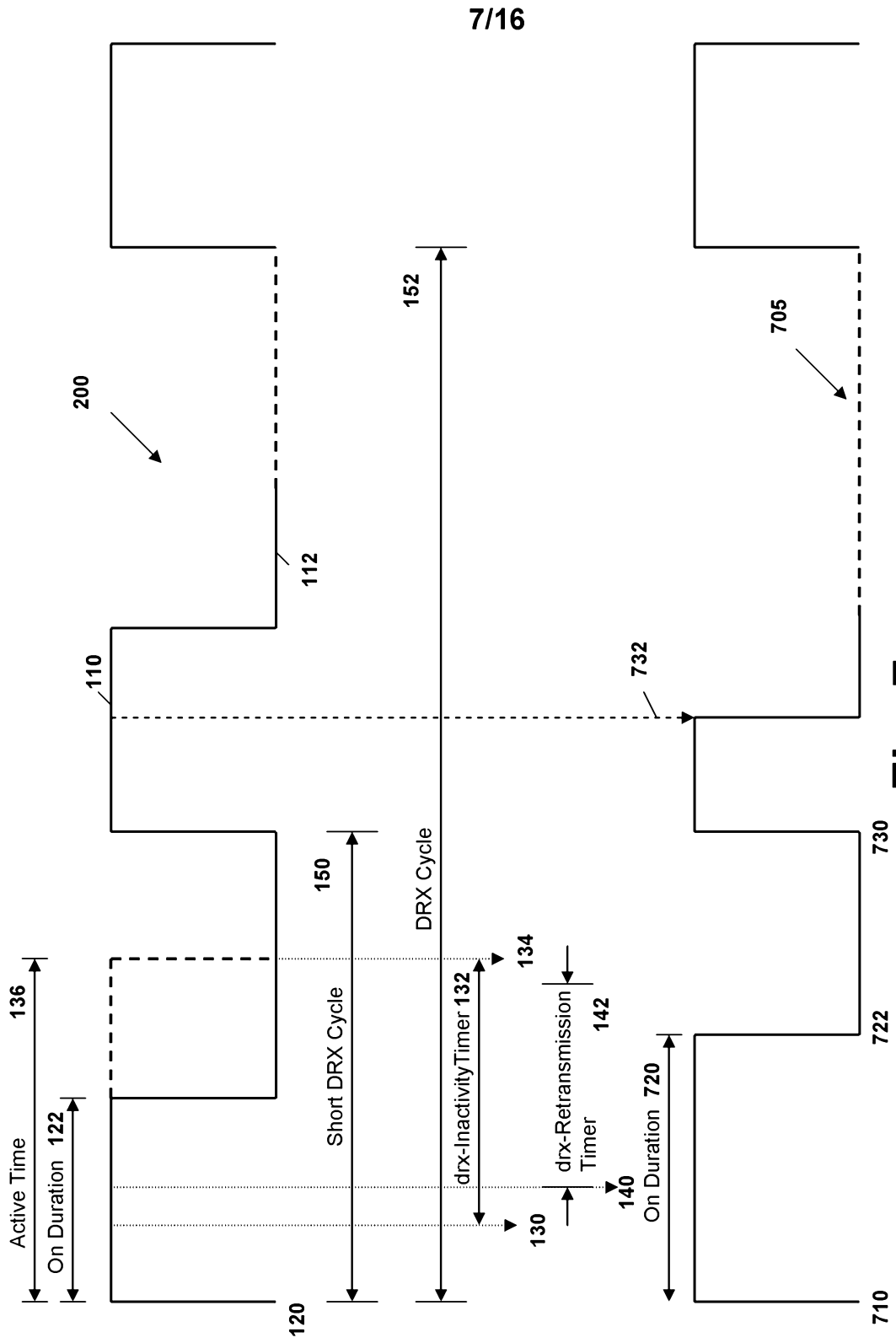

Fig. 7

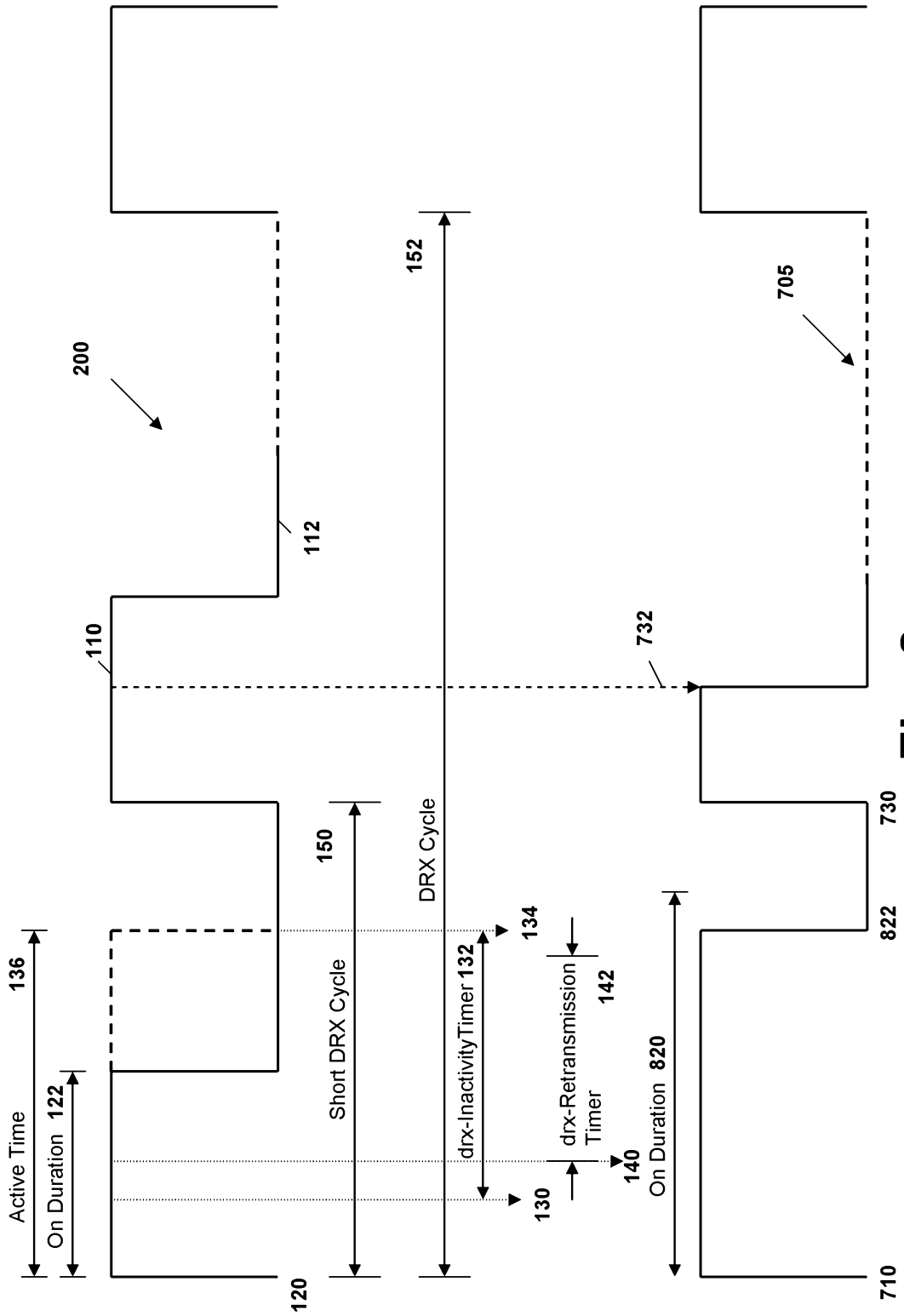

Fig. 8

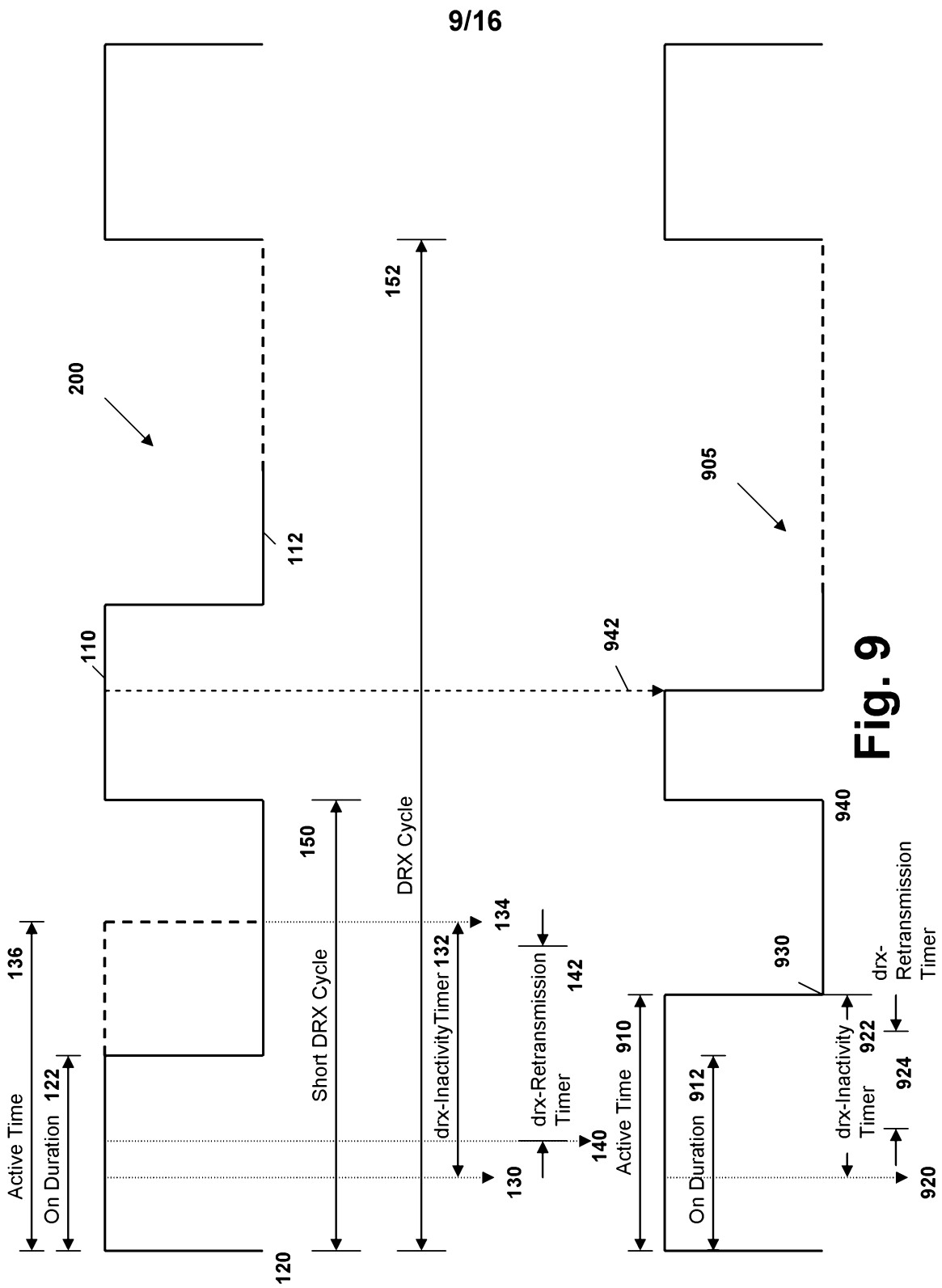

Fig. 9

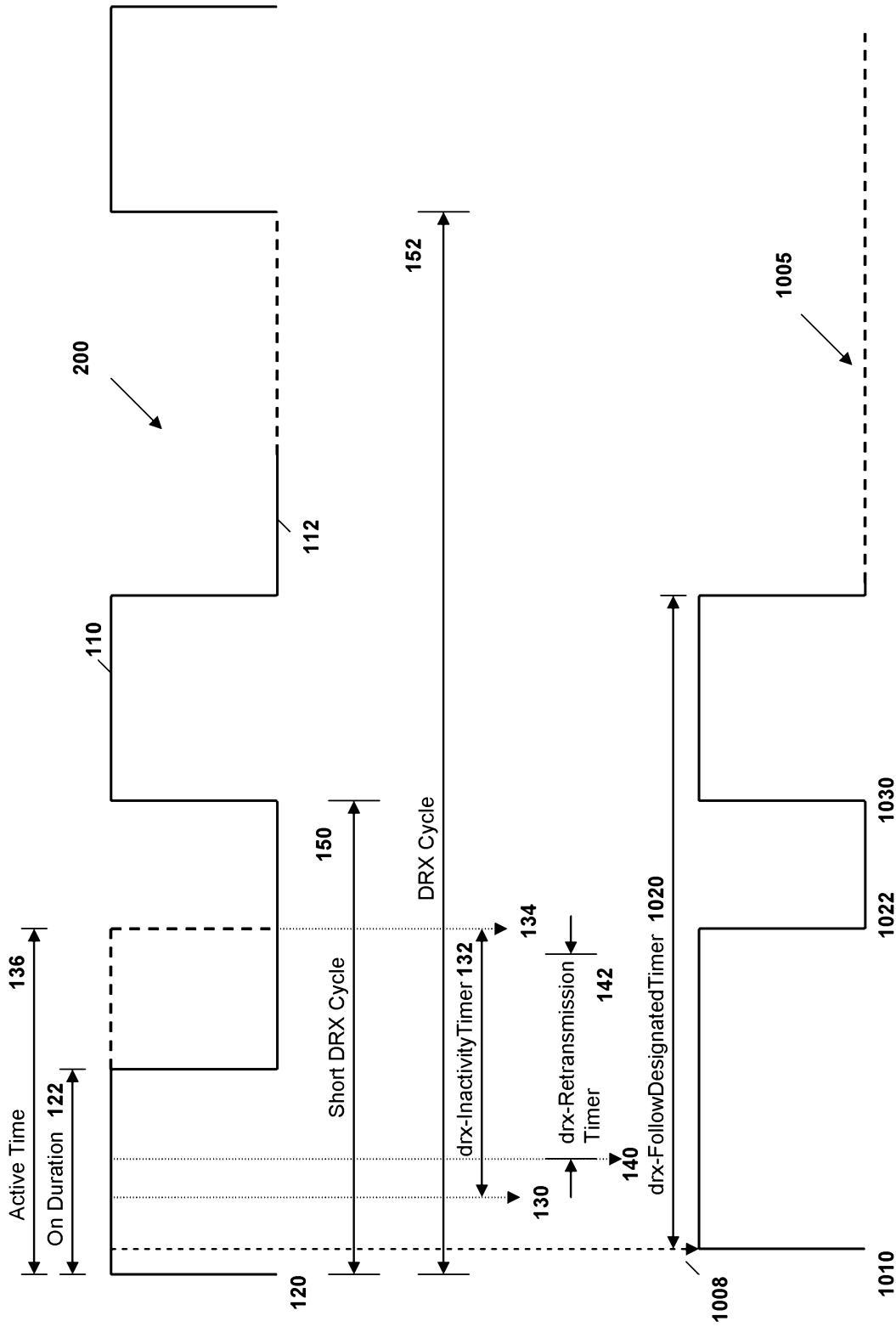

Fig. 10

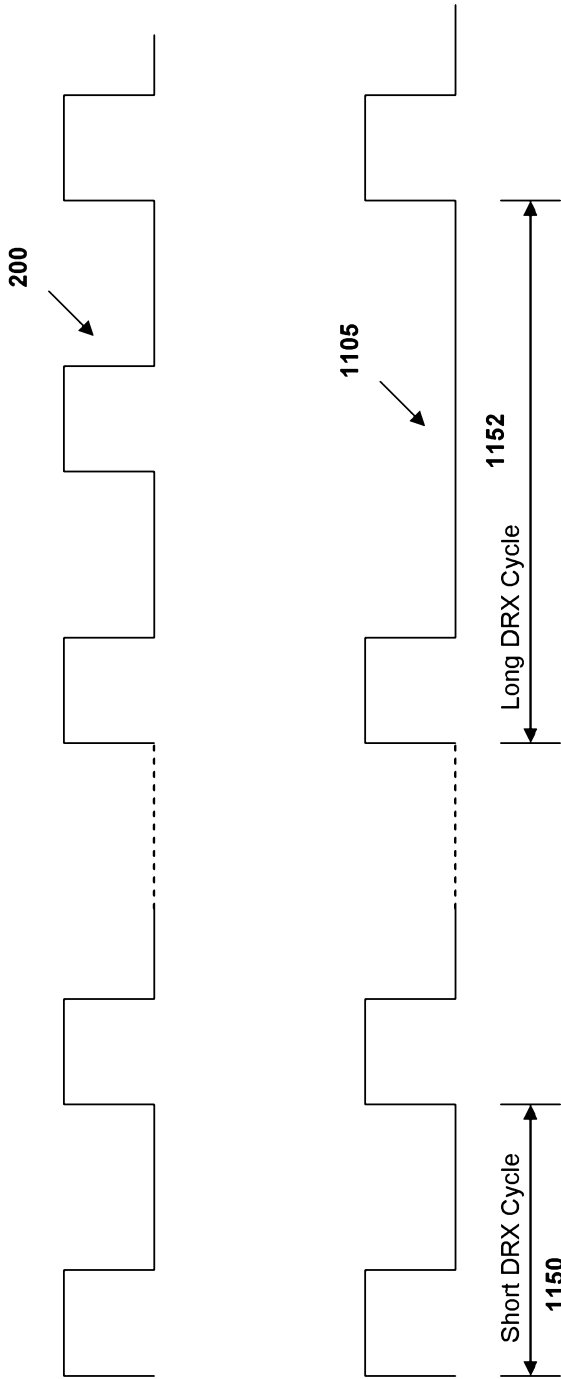

Fig. 11

12/16

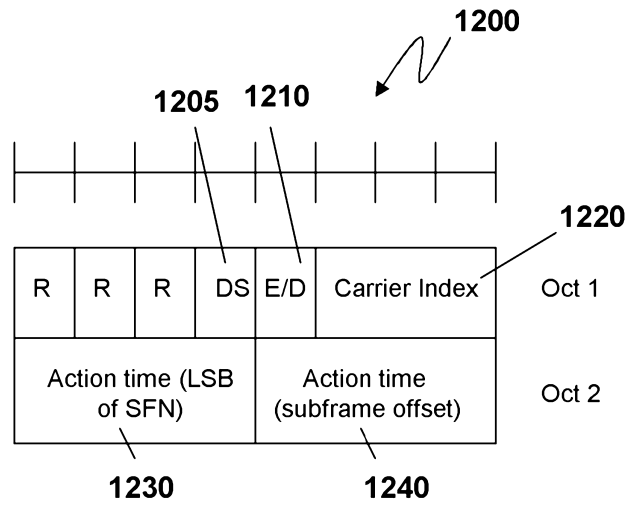

Fig. 12

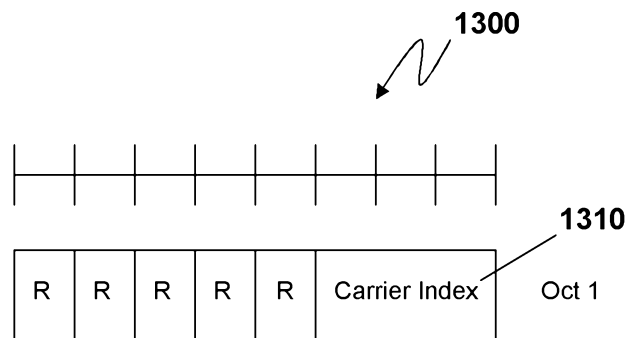

Fig. 13

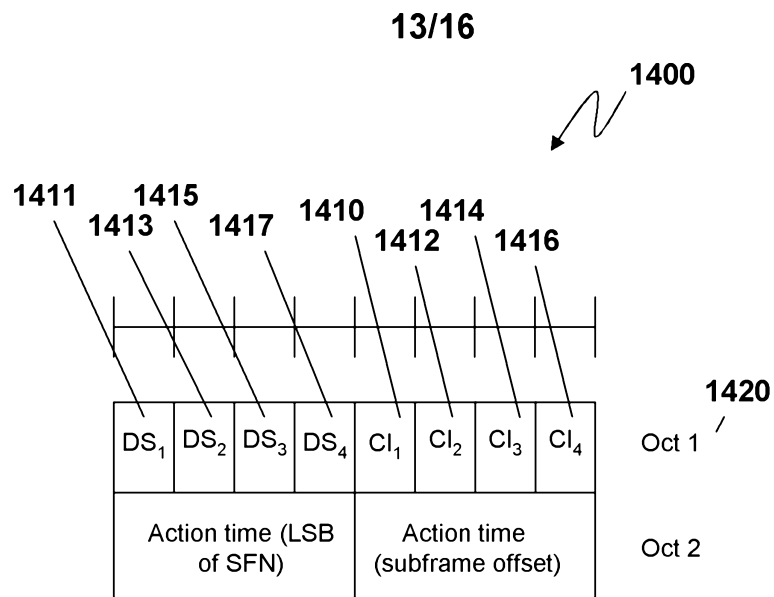

Fig. 14

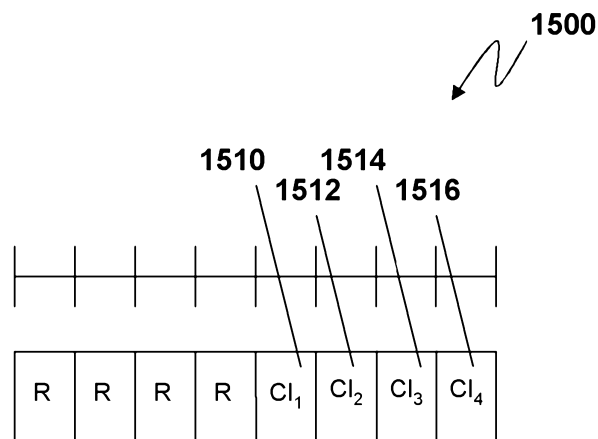

Fig. 15

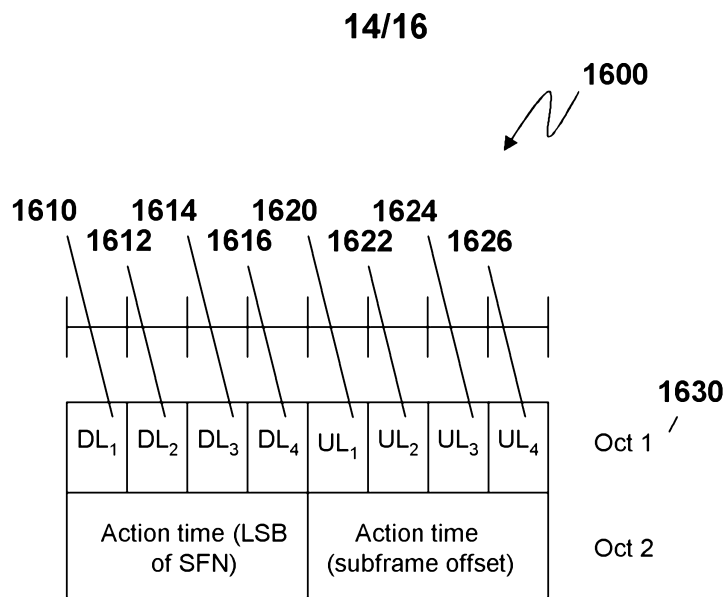

Fig. 16

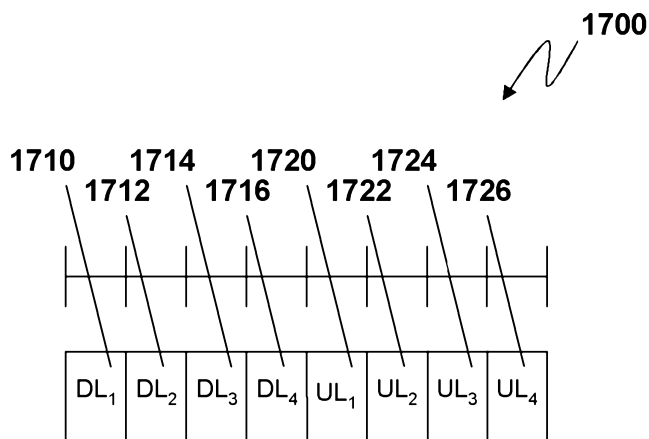

Fig. 17

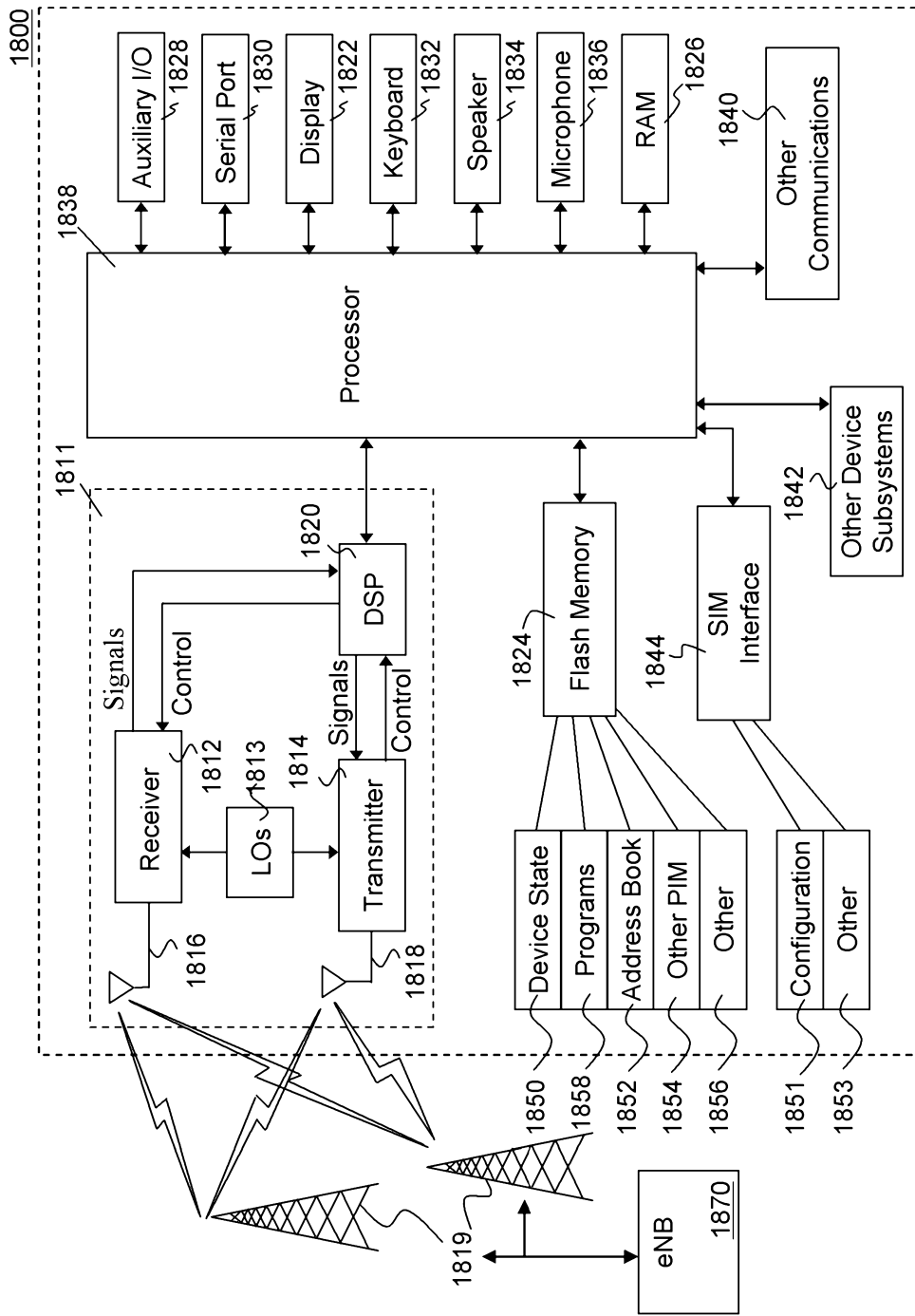

FIG. 18

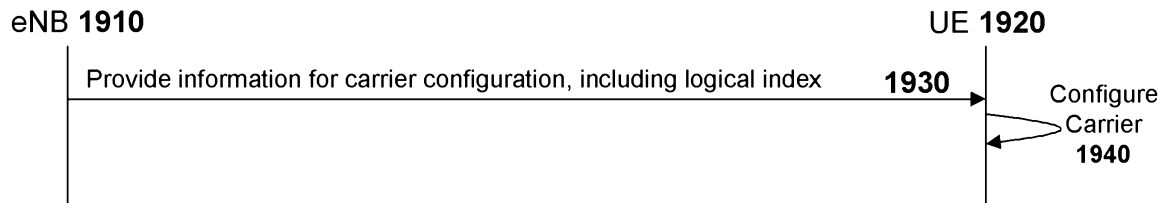

Fig. 19

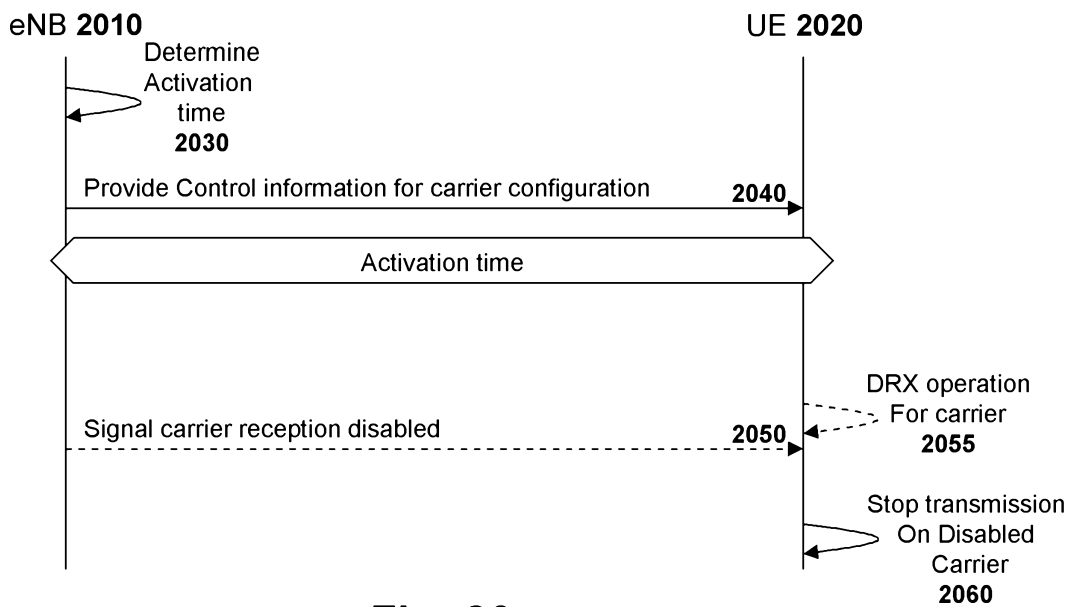

Fig. 20