

May 28, 1935.

H. L. FISCHER

2,003,111

OIL BURNER

Filed Oct. 3, 1932

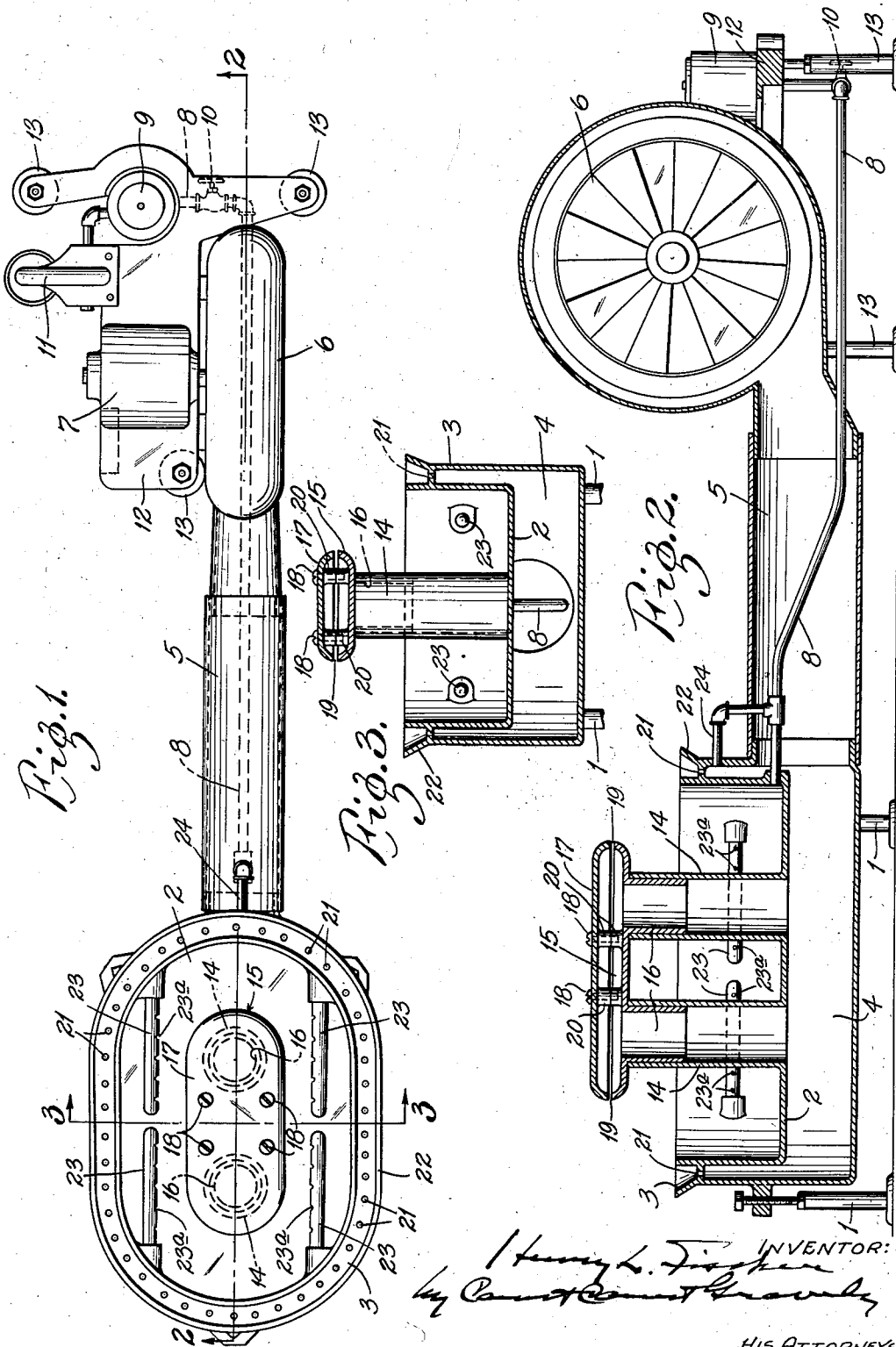

Henry L. Fischer INVENTOR:
by *Conant & Conant*
HIS ATTORNEYS

UNITED STATES PATENT OFFICE

2,003,111

OIL BURNER

Henry L. Fischer, East St. Louis, Ill., assignor to
Eagle Foundry Company, Belleville, Ill., a cor-
poration of Illinois

Application October 3, 1932, Serial No. 635,940

4 Claims. (Cl. 158—92)

This invention relates to oil burners of the type wherein the oil supplied to the fire pot forms a pool in the bottom thereof and is vaporized by incoming streams of air immediately above the oil pool and adjacent to the top of said fire pot or retort. The invention has for its principal objects to secure a more complete and perfect combustion by a more uniform distribution of the air flowing to the fire pot, to provide an oil pilot, to preheat and vaporize the oil passing through the oil supply pipe and to provide for simplicity and cheapness of construction and compactness of design. The invention consists in the oil burner and in the construction, combinations and arrangements of parts hereinafter described and claimed.

In the accompanying drawing, which forms part of this specification and wherein like symbols refer to like parts wherever they occur,

Fig. 1 is a plan view of an oil burner embodying my invention,

Fig. 2 is a vertical longitudinal section on the line 2—2 in Fig. 1; and

Fig. 3 is a vertical transverse section on the line 3—3 in Fig. 1.

My oil burner comprises an oval-shaped casting supported on legs 1 and containing a fire pot 2 that is surrounded by a suitable casing 3, forming a chamber 4 beneath the bottom and around the sides of said fire pot. Air under pressure is supplied to the lower portion of the chamber 4 by means of a duct 5 leading from a fan or blower 6 driven by an electric motor 7. Oil is supplied to the lower portion of the fire pot through a pipe 8 or conduit leading from a suitable source of oil supply through the air duct 5. The electric motor 7 is a two-speed motor that is controlled by a suitable room thermostat (not shown) so as to operate at either high or low speed in accordance with temperature requirements. A suitable magnetic by-pass valve 9 is also located in the oil supply pipe 8 for supplying a full flow of oil to the fire pot when the motor is operating at high speed and for supplying a smaller amount of oil to provide an oil pilot when the motor is operating at low speed and the main oil supply is cut off. The usual regulator valve 10 is also located in the oil line for regulating the flow of oil therethrough; and a suitable constant level valve 11 is located in the oil supply pipe for maintaining the desired depth of oil in the fire pot. The fan, motor, magnetic by-pass valve, regulator valve and constant level valve are all mounted on a suitable stand 12 provided with supporting legs 13.

Extending upwardly from the bottom of the fire pot 2 adjacent to the center thereof are two air conduits 14 which communicate at their lower ends with the portion of the air chamber 4 located beneath said fire pot. The two upstanding air conduits 14 extend above the side walls of the fire pot and have their upper ends capped by a single distributor head 15 having downwardly extending tubular portions 16 that fit within the upper ends of said upstanding air conduits. The distributor head 15 is provided with a cap 17, which is removably secured in position by means of bolts 18 that pass through holes provided therefor in lugs 20 that serve to space said cap far enough above the lower portion of said head to form a horizontal air discharge opening 19 that extends continuously around the same. Additional air is supplied around the upper edge of the fire pot by means of a series of openings 21 which are formed in the top of the casing 3 and lead from the upper portion of the air chamber 4. Excessive outward spreading of the air that is delivered around the upper edge of the fire pot is prevented by an upwardly and outwardly inclined flange 22 at the upper corner of the casing 3. Air from the chamber 4 is supplied to the interior of the fire pot through two horizontally disposed pipes or conduits 23 that extend inwardly from opposite ends of the fire pot on each side of the distributor head 15 and are provided with a series of longitudinally spaced air discharge openings 23a. These air supply pipes 23 are located substantially midway between the top and bottom of the fire pot just above the level of the pool of oil therein. A pipe or conduit 24 communicates at one end with the upper portion of the air chamber 4 and at its other end with the oil supply pipe 8 adjacent to the discharge end thereof. The pipe 24 serves to supply hot air from the air chamber 4 to the discharge end of the oil supply pipe and thus tends to heat and vaporize the oil passing therethrough.

By the arrangement described, it will be seen that air is delivered by the fan 6 to the air chamber and after being heated by the heat from the fire pot, is uniformly distributed inside the fire pot above the fire pot and around the outer edge thereof. Thus, air supplied to the interior of the fire pot mixes with the vapors from the body of oil in the bottom thereof and forms a combustible mixture which is partly burnt therein. The unburned oil vapors are then commingled with the air streams above the pot and around the edges thereof where they are thoroughly vaporized or atomized and a complete and final combustion

occurs. The pipe 24 leading from the air chamber 4 to the discharge end of the oil supply line 8 serves to supply warm air to said pipe, thereby tending to heat and vaporize the oil passing there-
 5 through. This supply of hot air to the oil supply pipe is particularly advantageous when only enough oil is flowing through said pipes to furnish an oil pilot light, such hot air tending to
 10 heat and vaporize such oil and thus insure combustion thereof.

Obviously, the hereinbefore described oil burner admits of considerable modification without departing from my invention. Therefore, I do not wish to be limited to the precise construction
 15 shown and described.

What I claim is:

1. An oil burner comprising a fire pot having an air chamber surrounding the bottom and sides thereof, means for delivering air to said chamber,
 20 an oil supply pipe opening into said fire pot, a conduit leading upwardly from said air chamber through the bottom of said fire pot, an outlet head at the upper end of said conduit, said chamber being provided with outlet openings adjacent to
 25 the upper edge of said fire pot, and a plurality of horizontally disposed pipes located inside said fire pot and communicating therewith and with said chamber.

2. An oil burner comprising a fire pot having
 30 an air chamber surrounding the bottom and sides thereof, means for delivering air to said chamber, an oil supply pipe opening into said fire pot, a conduit leading upwardly from said air chamber

through the bottom of said fire pot, a discharge head for said conduit, horizontally disposed pipes located inside said fire pot and communicating with said chamber, and a pipe located outside of
 5 said chamber and communicating at one end with said chamber adjacent to the top thereof and at the other end with said oil supply pipe adjacent to the discharge end thereof.

3. An oil burner comprising an oval fire pot having a chamber surrounding the bottom and
 10 sides thereof, means for supplying air to said chamber, an oil supply pipe opening into said pot, an air discharge pipe leading upwardly from said chamber through the bottom of said fire pot, and
 15 a plurality of horizontally arranged air discharge pipes disposed inside of said pot on each side of said upwardly extending discharge pipe and communicating with the portion of said chamber which surrounds the sides of said fire pot.

4. An oil burner comprising an oval fire pot
 20 having a chamber surrounding the bottom and sides thereof, means for supplying air to said chamber, an oil supply pipe opening into said pot, an air discharge pipe leading upwardly from
 25 said chamber through the bottom of said fire pot, and a plurality of horizontally arranged air discharge pipes disposed inside of said pot on each side of said upwardly extending discharge pipe and communicating with said chamber, said pipes extending longitudinally of said pot from opposite
 30 ends thereof.

HENRY L. FISCHER.