

(19) World Intellectual Property Organization  
International Bureau



(43) International Publication Date  
7 February 2008 (07.02.2008)

PCT

(10) International Publication Number  
**WO 2008/016486 A2**

(51) International Patent Classification:  
A61M 5/142 (2006.01) A61B 5/00 (2006.01)

(21) International Application Number:  
PCT/US2007/016199

(22) International Filing Date: 17 July 2007 (17.07.2007)

(25) Filing Language: English

(26) Publication Language: English

(30) Priority Data:  
11/496,606 31 July 2006 (31.07.2006) US

(71) Applicant (for all designated States except US):  
**MEDTRONIC MINIMED, INC.** [US/US]; 18000  
Devonshire Street, Northridge, CA 91325-1219 (US).

(72) Inventors: **GOLDSMITH, Joel**; 4515 Babcock Avenue,  
Studio City, CA 91604 (US). **HAYES, Andrew, C.**; 691  
Summer Tree Court, Simi Valley, CA 93065 (US).

(74) Agents: **DAVOUDIAN, Keyvan** et al.; Pillsbury  
Winthrop Shaw Pittman LLP, 725 South Figueroa Street,  
Suite 2800, Los Angeles, CA 90017-5406 (US).

(81) Designated States (unless otherwise indicated, for every kind of national protection available): AE, AG, AL, AM, AT, AU, AZ, BA, BB, BG, BH, BR, BW, BY, BZ, CA, CH, CN, CO, CR, CU, CZ, DE, DK, DM, DO, DZ, EC, EE, EG, ES, FI, GB, GD, GE, GH, GM, GT, HN, HR, HU, ID, IL, IN, IS, JP, KE, KG, KM, KN, KP, KR, KZ, LA, LC, LK, LR, LS, LT, LU, LY, MA, MD, ME, MG, MK, MN, MW, MX, MY, MZ, NA, NG, NI, NO, NZ, OM, PG, PH, PL, PT, RO, RS, RU, SC, SD, SE, SG, SK, SL, SM, SV, SY, TJ, TM, TN, TR, TT, TZ, UA, UG, US, UZ, VC, VN, ZA, ZM, ZW.

(84) Designated States (unless otherwise indicated, for every kind of regional protection available): ARIPO (BW, GH, GM, KE, LS, MW, MZ, NA, SD, SL, SZ, TZ, UG, ZM, ZW), Eurasian (AM, AZ, BY, KG, KZ, MD, RU, TJ, TM), European (AT, BE, BG, CH, CY, CZ, DE, DK, EE, ES, FI, FR, GB, GR, HU, IE, IS, IT, LT, LU, LV, MC, MT, NL, PL, PT, RO, SE, SI, SK, TR), OAPI (BF, BJ, CF, CG, CI, CM, GA, GN, GQ, GW, ML, MR, NE, SN, TD, TG).

**Published:**  
— without international search report and to be republished upon receipt of that report



**WO 2008/016486 A2**

(54) Title: WATCH CONTROLLER FOR A MEDICAL DEVICE

(57) Abstract: An infusion system that includes a watch controller device and a communication system to transmit the communications from the watch controller device to an infusion device pump that controls delivery of fluids to the user's body. More particularly, these apparatuses and methods are for providing convenient monitoring and control of the infusion pump device in determining the appropriate amount of insulin to deliver.

## WATCH CONTROLLER FOR A MEDICAL DEVICE

### RELATED APPLICATIONS

**[0001]** This patent application is a continuation-in-part of U.S. Patent Application No. 11/204,583, filed on August 16, 2005 and a continuation-in-part of U.S. Application No. 11/204,667, filed on August 16, 2005, which are herein incorporated by reference.

### FIELD OF THE INVENTION

**[0002]** Embodiments of this invention relate generally to infusion systems and methods for delivering fluids into an individual's body and monitoring systems and methods for monitoring analyte levels in an individual's body. More particularly, embodiments of this invention relate to apparatuses and methods for providing a convenient way in which to monitor and control the fluids delivered to the individual's body and to monitor the analyte levels in the individual's body.

### DESCRIPTION OF THE RELATED ART

**[0003]** Patients with Type-1 diabetes and some patients with Type 2 diabetes use insulin to control their blood glucose (BG) level. Diabetics must modify their daily lifestyle to keep their body in balance. To do so, diabetics need to keep strict schedules, including ingesting timely nutritious meals, partaking in exercise, monitoring BG levels daily, and adjusting and administering insulin dosages accordingly. Testing of BG levels has been both painful and awkward for the patient. Traditionally, insulin dependent diabetics were required to monitor their BG levels by puncturing a finger tip with a needle. Due to the fact that many patients must conduct such a test multiple times throughout the day to regulate their BG levels, the procedure can be painful and inconvenient.

**[0004]** Typically, patients may employ various calculations to determine the amount of insulin to inject. For example, bolus estimation software is available for calculating an insulin bolus. Patients may use these software programs on an electronic computing device, such as a computer, the Internet, a personal digital assistant (PDA), or an insulin delivery device. Insulin delivery devices include infusion pumps, injection pens, and implantable delivery systems. The better bolus estimation software takes into account the patient's present BG level. Presently, a patient must measure his/her blood glucose using a BG measurement device, such as a test strip meter, a continuous glucose

measurement system, or a hospital hemacue. BG measurement devices use various methods to measure the BG level of a patient, such as a sample of the patient's blood, a sensor in contact with a bodily fluid, an optical sensor, an enzymatic sensor, or a fluorescent sensor. When the BG measurement device has generated a BG measurement, the measurement is displayed on the BG measurement device. Then the patient may visually read the BG measurement and physically enter the BG measurement into an electronic computing device to calculate a bolus estimate. Finally, once the bolus estimate is calculated, the patient must inject the insulin bolus or program an insulin delivery device to deliver the bolus into their body. Unfortunately, this process is also cumbersome and is subject to transcribing errors—for example, the patient may inaccurately enter the BG measurement that is displayed on the BG measurement device into the electronic computing device. Thus, if the BG measurement is not entered correctly, the bolus estimate is not accurate, which may lead to the delivery of an inappropriate insulin dose. In other devices, the measurement is transmitted to the electronic computing device.

**[0005]** In infusion systems where a display is included for convenient viewing of selected information, such as that requested by the user or an instructed act that was undertaken by an infusion device or a sensing device, the display is generally located on the device. This may be inconvenient for the user to view information because infusion devices and sensors are typically secured to or near a site on the user's body. Thus, viewing may require the user to move or manipulate the infusion device or sensor to view the display which may lead to improper reading of the display.

#### BRIEF SUMMARY OF THE INVENTION

**[0006]** In accordance with embodiments of the invention, an infusion system is provided that allows for the control of the delivery of a fluid or medication. An embodiment of the present invention includes a controller device and a therapy/diagnostic device, such as an infusion device. The controller device may be a hand-held device, separate from the infusion device, that allows the user to communicate with the infusion device without actually handling the infusion device.

**[0007]** The controller device includes a housing adapted to be carried by the user and a communication system contained in the housing for transmitting a communication or command from the user to the infusion device. In alternative embodiments, the controller device may receive communications sent from the infusion device or other

components of the infusion system, such as for example, a characteristic determining device. Further, the controller device may include a user input device on the controller device housing, such as keys, buttons, or the like, for the user to input data or commands.

**[0008]** The controller device includes on the housing a display that may mimic the display on the infusion device. In certain embodiments, whatever is shown on the infusion device corresponds to that shown and reflected on the display of the controller device. The controller device display shows information according to communications sent to it from the infusion device. The user may more conveniently view what is being processed or acted upon in the infusion device without removing or adjusting the infusion device to view the display. In further embodiments, the controller device may be configured so that the input devices included allow all, or substantially all, viewing and data entry to be performed on the controller device without moving or referring to the infusion device.

**[0009]** In further embodiments, the controller device may control an analyte sensing device such as a continuous glucose sensor. The controller device display shows information according to communications sent to it from the sensing device. In further embodiments, the controller device may control more than one device, for example, an infusion pump and an analyte sensor.

**[0010]** In further embodiments, the controller device may include time-telling functions. For example, the controller device may be a wrist-worn device, such as a watch. The controller device may also be a watch that can be carried on other parts of the body or clothing, such as the ankle, neck (e.g., on a chain), pocket, or ankle.

**[0011]** Among other advantages, embodiments of the present invention may provide convenience and ease of use. For example, an embodiment with a user interface and display on the controller device may cater to the active lifestyles of many insulin dependent diabetics. A large and simple display minimizes the potential for error in reading and interpreting test data. A small overall size permits discretion during self-monitoring and makes it easy to carry. In another embodiment, the controller device may be integrated with a characteristic determining device into one housing and feature a large target area for strip insertion to make the monitoring procedure fast and accurate. In some embodiments, the controller device display may include a dedicated backlight to facilitate viewing.

**[0012]** The controller device also reflects the other functions that the particular infusion device may show, including a variety of other displays, for example, when the

last bolus was administered, when the last alarm occurred, when the last finger stick was taken, past trends, all alarms that occurred in a time period, calibrations, meals, exercise, bolus schedules, temporary basal delivery, diagnostic information, and the like. Whenever a bolus is being delivered, the infusion device can send a message every time a tenth of a unit, or some specified amount, is delivered, to which the user may monitor via the controller device display.

**[0013]** In certain embodiments, the infusion device is the central hub with peripheral devices being the controller device and a characteristic determining device. The characteristic determining device being adapted to sense and determine the concentration of an analyte of a patient and directs the infusion device fluid delivery according to the measurements. While the term "analyte" is used herein, it is possible to determine and use other characteristics as well using the same type of system. The control is maintained in the central hub and the infusion device sends out most of the commands. The infusion device also sends requests to receive specific data from the controller device and the characteristic determining device, if one is included.

**[0014]** In particular embodiments, where the controller device is integrated with the characteristic determining device into one housing, the controller device may automatically transmit communications including the data indicative of the determined concentration of the analyte in the user to the infusion device. In other particular embodiments, the controller device further includes a user input device for inputting commands, and transmits the communications to the infusion device in response to a command from the user input device. In additional embodiments, the controller device further includes an indicator to indicate a status of the communication including the data indicative of the determined concentration of the analyte in the user being transmitted from the determining device communication system to the infusion device communication system. Data compression may be employed to speed up communications.

**[0015]** In further embodiments, the infusion device may contain all or substantially all of the intelligence. The amount of time that the controller communicates with the infusion device or other components may be limited to save power in the controller device. For example, radio-frequency (RF) communications may be minimized, such that the marriage between the infusion device and controller occurs once until further communication is necessary to exchange data. The information regarding the screens displayed is sent to the controller, and when the infusion device needs to display a screen,

it sends a screen number to the controller. In the case of screen displays, if the data being sent is fixed, then the screen can be simply displayed. If the data is variable, then the variable data is sent with the screen to the infusion device. Exchange IDs, strings to be displayed, and foreign languages are among data that may be sent from the controller. Further commands that may be sent from the infusion device include, among other commands, a command to show a specific screen on the controller device, a command for displaying requested information on the screen, a command for showing the rules for the input devices, a command for showing the intelligence about that screen type (*e.g.*, menus, data entries, etc.), and the like.

**[0016]** The controller device and the infusion device may communicate to one another through wireless or non-wireless methods. Some examples of wireless methods include, by no way in limitation, RF, infrared (IR), Bluetooth, ZigBee, and other 802.15 protocols, 802.11 WiFi, spread spectrum communication, and frequency hopping communication. Further examples include giving the controller device cellular telephone or pager capabilities. In the alternative, the communication may be wired, such as in hospital use. In a wired embodiment, there may be a tether physically connecting the infusion device to the controller device. In yet another alternative, the controlling device and the infusion device could be both wired and wireless—when wired, the two components communicate by wire, and when disconnected, the two components could operate through wireless communication.

**[0017]** In another wireless example, if the user has access to a computer network or phone connection, the user can open communication via the internet to obtain communications from, and send communications to, a nurse, parent, or anyone so desired. A transceiver may be used to facilitate data transfer between the PC and the infusion device. Such a communication may also be used by a party, other than the user, to control, suspend, and/or clear alarms. This embodiment could be very useful for a parent to monitor the infusion system of a child, or for a physician to monitor the infusion system of a patient. As a non-limiting example, further description of a communication station may be found in U.S. Patent. No. 5,376,070, which is herein incorporated by reference. The transceiver may allow patients at home or clinicians in a hospital setting to communicate with the various components of the infusion system via RF telemetry. The transceiver may be used to download device information from the infusion device and sent to the PC when the transceiver is connected in to the serial port of the PC. In embodiments, the

transceiver may derive its power from the PC when the two are connected. In this way, the transceiver conveniently does not require a separate power source. In another embodiment, a cellular phone may be used as a conduit for remote monitoring and programming. In yet other embodiments, the controller device may also act as a transceiver, which would eliminate an extra component.

**[0018]** In yet further embodiments, the infusion system includes an infusion device and/or a sensing device. The sensing device includes a sensor and a transmitter in communication with the infusion device. The transmission may occur via wire or wireless methods. The sensing device includes a sensor and a transmitter in communication with the infusion device. The sensing device may sense an analyte of a bodily fluid of the user and provide continuous monitoring of that analyte. The sensing device may be calibrated using data from the infusion device and/or from a characteristic determining device. In further embodiments, the sensing device senses additional physiological characteristics. In still further embodiments, the system is set up to automatically call for assistance when analytes reach a certain level. The system may be set up to notify others, for example, through a cellular network. In such a manner, the patient's cellular telephone may be used to connect to emergency services. The call may include a global positioning system (GPS) location. GPS functions may be included separately from cellular telephone type functions.

**[0019]** Communications between the system components may be performed in a variety of manners. In an embodiment using RF options, there could be employed a "spread spectrum" where a large range of RFs can be used to relay the communication. In another embodiment, changing frequencies can be used so as to pick up whatever frequency is present. This is known as frequency hopping, where the frequency changes periodically or so to take advantage of all, or substantially all, frequencies available. Another embodiment is one that uses adaptive frequency selection, or Listen Before Talk (LBT), where the devices select the cleanest available channel from those allotted prior to transmitting. In some cases, frequency hopping allows the system to find frequencies that are not being used by other nearby systems and thus avoid interference. In addition, a system may operate in a manner where each component-to-component communication is on a different frequency, or where the delay for each communication is different. Other types of RF, that are not described, may also be used for communication, such as, translation frequency.

### BRIEF DESCRIPTION OF THE DRAWINGS

- [0020] A detailed description of embodiments of the invention will be made with reference to the accompanying drawings, wherein like numerals designate corresponding parts in the figures.
- [0021] Fig. 1 is a front view of a controller device according to an embodiment of the invention.
- [0022] Fig. 2 is a front view of a blood glucose meter integrated into a controller device housing according to an embodiment of the invention.
- [0023] Fig. 3 is a front view of a blood glucose meter integrated into a controller device housing according to another embodiment of the invention.
- [0024] Fig. 4 is a front view of a blood glucose meter integrated into a controller device housing communicating with an infusion device according to an embodiment of the invention.
- [0025] Fig. 5 is a block diagram of an RF communication system in the infusion device according to an embodiment of the invention.
- [0026] Fig. 6A is a block diagram of a controller device according to an embodiment of the invention.
- [0027] Fig. 6B is a block diagram of a controller device according to an embodiment of the invention.
- [0028] Fig. 7 is a block diagram of different communication paths within the infusion system according to an embodiment of the invention.
- [0029] Fig. 8 is a diagram of the electronics architecture of a controller device according to an embodiment of the invention with a custom integrated circuit.
- [0030] Fig. 9A is a front view of a combined watch and controller device according to an embodiment of the invention.
- [0031] Fig. 9B is a rear view of a combined watch and controller device according to an embodiment of the invention.
- [0032] Fig. 10 is a block diagram of a combined watch and controller device according to an embodiment of the invention.

### DETAILED DESCRIPTION OF THE INVENTION

**[0033]** In the following description, reference is made to the accompanying drawings which form a part hereof and which illustrate several embodiments of the present inventions. It is understood that other embodiments may be utilized and structural and operational changes may be made without departing from the scope of the present inventions.

**[0034]** In one embodiment, the controller device is a hand-held device separate from the therapy/diagnostic device, such as an infusion device, that allows the user to communicate with the therapy/diagnostic device without actually handling the device. Other examples of therapy/diagnostic devices include electronic therapy devices and devices that receive diagnostic information from cardiac and other sensors. As illustrated in Fig. 1, the controller device 5 includes a housing 3 adapted to be carried by the user and a communication system (not shown) contained in the housing 3 for transmitting a communication or command from the user to the infusion device. In further embodiments, the controller device 5 may receive communications sent from the infusion device or other components of the infusion system, such as for example, a characteristic determining device. Further, the controller device may include one or more user input devices 2a and 2b on the controller device housing 3, such as keys, buttons, or the like, for the user to input data or commands. The controller device 5 includes a display 4 on the controller device housing 3 which simultaneously displays whatever information and/or graph is being displayed on the infusion device display at that moment. The display 4 allows a user to easily monitor and control what actions are taking place in, or being performed by, the infusion device. In some embodiments, the controller device 5 may further include a backlight 1 in the controller device display 4 for easier viewing. The backlight may be adapted to be in one or more colors, which can be user selectable for personalized use. In further embodiments, the backlight may be adapted to flash and/or turn to a color such as yellow or red when various alerts and alarms take place. In additional embodiments, the controller device 5 may include accessories such as hand straps 6 to provide convenient handling. In particular embodiments, the controller is sized smaller than 6 inches long by 4 inches wide by 1 inch thick.

**[0035]** In certain embodiments, a characteristic determining device that senses and determines the concentration of an analyte of a patient, for example blood glucose ("BG"), and controls the infusion device according to the measurements, may be included in an infusion system with the controller device and the infusion device. The characteristic

determining device includes a housing, a receptacle coupled to the housing for receiving and testing an analyte from the user to determine a concentration of the analyte in the user, a processor contained in the housing and coupled to the receptacle for processing the determined concentration of the analyte from the receptacle, and a communication system contained in the housing and coupled to the processor for transmitting a communication including data indicative of the determined concentration of the analyte in the user. In particular embodiments, the characteristic determining device may also include a lancing device coupled to the receptacle for obtaining the analyte from the user.

**[0036]** In embodiments, the infusion device includes a housing adapted to be carried by the user, a drive mechanism contained in the housing and operatively coupled with a reservoir containing the fluid for infusing the fluid into the body of the user, a communication system contained in the housing for receiving the communication including the data indicative of the determined concentration of an analyte in the user from a characteristic determining device, and a processor contained in the housing and coupled to the communication system for processing the data indicative of the determined concentration of the analyte in the user and controlling the infusion device. In particular embodiments, the infusion device is sized smaller than 6 inches long by 4 inches wide by 1 inch thick.

**[0037]** The infusion device may further include a bolus estimator used in conjunction with the processor for calculating an estimated amount of fluid to be infused into the body of the user based upon the received data indicative of the determined concentration of the analyte in the user and a target concentration of the analyte in the user, and an indicator to indicate when the estimated amount of fluid to be infused has been calculated. The system may determine the concentration of one of any variety of analyte types including, but not limited to, oxygen, blood, temperature, lactase, pH, implantable, and the like. Additionally, the infusion device may include a user input device, such as keys, buttons, or the like, for inputting an estimate of a material to be ingested by the user, and the bolus estimator may include the capability to calculate the estimated amount of fluid to be infused into the body of the user based upon the inputted estimate of the material to be ingested by the user. The infusion device may also include a memory for storing the data indicative of the determined concentration of the analyte in the user received by the infusion device communication system from the determining device communication system.

**[0038]** In still further alternative embodiments, the characteristic determining device is a BG measurement device and may use samples from body fluids other than blood, such as interstitial fluid, spinal fluid, saliva, urine, tears, sweat, or the like. In yet other alternative embodiments, other measurement devices may be utilized to determine the concentrations, levels, or quantities of other characteristics, analytes, or agents in the user, such as hormones, cholesterol, oxygen, pH, lactate, heart rate, respiratory rate, medication concentrations, viral loads (e.g., HIV), or the like. In still other alternative embodiments, other fluids may be delivered to the user, such as medication other than insulin (e.g., HIV drugs, drugs to treat pulmonary hypertension, iron chelation drugs, pain medications, and anti-cancer treatments), chemicals, enzymes, antigens, hormones, vitamins, or the like. Particular embodiments are directed towards the use in humans; however, in alternative embodiments, the infusion devices may be used in animals. For pain management, a bolus function may be set up as a Patient Controlled Analgesic (PCA) function for customized delivery or the user may press a preset bolus button several times.

**[0039]** In other embodiments, the characteristic determining device is a BG meter that determines BG level and the infusion device is an insulin infusion pump. The BG meter communicates the measurement of BG to the infusion pump device to determine the amount of insulin for delivery to the user. In alternative embodiments, the BG measurement device may be a continuous glucose measurement system, a hospital hemacue, an automated intermittent blood glucose measurement system, and the like, and/or the BG measurement device may use other methods for measuring the user's BG level, such as a sensor in contact with a body fluid, an optical sensor, a RF sensor, an enzymatic sensor, a fluorescent sensor, a blood sample placed in a receptacle, or the like. The BG measurement device may generally be of the type and/or include features disclosed in U.S. Patent Applications Serial No. 09/377,472 filed August 19, 1999 and entitled "Telemetered Characteristic Monitor System and Method of Using the Same," Serial No. 09/334,996 filed June 17, 1999 and entitled "Characteristic Monitor with a Characteristic Meter and Method of Using the Same," Serial No. 09/487,423 filed January 20, 2000 and entitled "Handheld Personal Data Assistant (PDA) with a Medical Device and Method of Using the Same," and Serial No. 09/935,827 filed August 23, 2001 and entitled "Handheld Personal Data Assistant (PDA) with a Medical Device and Method of Using the Same," which are herein incorporated by reference. Such BG measurement devices may be adapted to be carried by the user, for example, in the hand, on the body, in

a clothing pocket, attached to clothing (e.g., using a clip, strap, adhesive, or fastener), and the like. In particular embodiments, the BG measurement device is sized smaller than 6 inches long by 4 inches wide by 1 inch thick.

**[0040]** In alternative embodiments of the invention, the BG meter may be integrated into the controller device housing, as shown in Fig. 2, where the controller device housing 15 includes a BG meter receptacle 20. The controller 10 includes a housing 15 adapted to be carried by the user, a BG meter receptacle 20 coupled to the housing 15 for receiving and testing BG level from the user to determine a concentration of the BG in the user. A BG test strip 25 that holds a use blood sample is inserted into the BG meter receptacle 20 for the testing by the controller device 10. In variations, the controller device 10 may have a cartridge-like mechanism which loads and presents the strip for testing and then ejects it. The controller device 10 has a display 30 on the housing 15 to show information requested by the user or an instructed act that was undertaken by the infusion device, such as for example, determined concentration of blood glucose levels, BG trends or graphs, such as described and disclosed in U.S. Patent Application Serial No. 10/624,177, entitled "System for Monitoring Physiological Characteristics," which is herein incorporated by reference. The display 30 may further include a dedicated backlight 35 to facilitate viewing. The backlight 35 may be a user programmable multi-color backlight that additionally performs the function of a visual indicator by flashing colors appropriate to the level of an alert or alarm. The backlight 35 may also have variable intensity (automatic or manual) to preserve the battery power and improved viewing. The controller 10 includes a keypad 40 on which various input devices, such as keys, buttons, or the like, are located. The keypad buttons 45a, 45b, 45c, and 45d are used by the user to select options and/or input information.

**[0041]** The power of the controller device and of the other various devices discussed herein may be provided from a battery. The battery may be a single use or a rechargeable battery. Where the battery is rechargeable, there may be a connector or other interface on a device to attach the device to an electrical outlet, docking station, portable recharger, or so forth to recharge the battery while in the device. It is also possible that a rechargeable battery may be removable from the device for recharging outside of the device, however, in some cases, the rechargeable battery may be sealed into the housing of the device to create a more water resistant or waterproof housing. The devices may be adapted to accommodate various battery types and shapes. In further embodiments, the

devices may be adapted to accommodate more than one type of battery. For example, a device may be adapted to accommodate a rechargeable battery and, in the event of battery failure or other need, also adapted to accommodate a readily available battery, such as a AA battery, AAA battery, or coin cell battery.

**[0042]** In Fig. 3, another embodiment of a controller device is shown. Again, the controller device 110 includes a housing 115 adapted to be carried by the user, and a BG meter receptacle 120 coupled to the housing 115 for receiving and testing BG level from the user to determine a concentration of the BG in the user. A BG test strip 125 that holds a user's blood sample is inserted into the BG meter receptacle 120 for the testing by the controller device 110. The controller device 110 has a display 130 on the housing 115 to show information requested by the user or an instructed act that was undertaken by the infusion device, such as for example, determined concentration of blood glucose levels, graphs of blood glucose level trends or fluid delivery information. The display 130 may include a dedicated backlight 135 to facilitate viewing. The controller device 110 includes a few input devices, such as keys, buttons, or the like, on the housing 115. The housing buttons 145a, 145b, and 145c are used by the user to select options and/or input information.

**[0043]** Fig. 4 illustrates an embodiment of an infusion system that includes an infusion device 50, and further includes a controller device integrated with a BG meter 10, where both share one housing. The controller device 10 communicates to the infusion pump device 50 through a wireless method, for example RF signals. The controller device 10 senses and determines the concentration of BG level of a patient and controls the infusion device 50 according to the measurements. This substantially reduces, if not eliminates, calculations on the part of the patient. In particular embodiments, the infusion device 50 includes a housing 55 adapted to be carried by the user. On the housing 55 there is included a display 60 that, like the BG meter display 30, shows information requested by the user or an instructed act that was undertaken by the infusion device 50. The infusion device 50 may not include a display, but in that case there should be a suspend/resume input and an action input for safety reasons. The BG meter display 30 shows information according to communications sent to the controller device 10 from the infusion device 50. At any moment, the display 60 of the infusion device 50 may show substantially the same information as shown on the controller device display 30. The two displays may mimic one another so that the user may choose to conveniently view the

selected information from the controller device 10 rather than the infusion device 50, which is usually attached to the user's body through the infusion set 75. The infusion device 50 delivers fluid from within the housing 55, through tubing 80 and into the infusion set 75 into the user's body at an infusion site. Further included on the infusion device 50 is a keypad 65 with various input devices, such as the keypad buttons 70a, 70b, and 70c illustrated in the figure.

**[0044]** Fig. 5 provides a block diagram of the infusion device 150. The infusion device 150 includes a drive mechanism 152 contained in the housing 172 and operatively coupled with a reservoir 154 containing the fluid for infusing the fluid into the body of the user, a communication system 156 contained in the housing 172 for receiving the communication from the controller device including data indicative of the determined concentration of the BG in the user from the BG meter, and a processor 158 contained in the housing 172 and coupled to the communication system 156 for processing the received communications and controlling the infusion device 150. The fluid is delivered from the reservoir 154 through an outlet 168 in the housing 172 and into the user's body via the tubing 180 and infusion set 175. The infusion device 150 may further include an indicator displayed on the display 160 to indicate when the estimated amount of fluid to be infused has been calculated. Additionally, the infusion device 150 may include one or more user input device(s), such as keys, buttons, and the like, for inputting an estimate of a material to be ingested by the user, and the estimated amount of fluid to be infused into the body of the user may be based upon this inputted estimate of material to be ingested. A bolus estimator may be used in conjunction with the infusion device processor for estimating the appropriate amount of fluid to be infused into the body of the user. There may be included a keypad 165 on which the one or more input device(s) are located. The infusion device 150 may also include a memory 166 for storing the data received by the infusion device communication system 156 from the controller device communication system.

**[0045]** In further embodiments, a speaker 164 is included to provide an alternative mode of communication. In an embodiment, the infusion device 150 may display a message that states "move nearer to pump" when the BG meter or controller device senses that the communication with the infusion device 150 is weak or interrupted. A similar message may be displayed if the BG meter or controller device senses some type of problem or malfunction. Alternatively, an alarm 162 may alert the user of any problem or malfunction by vibrating, emitting warning sounds, flashing light, and the like. In further

embodiments, the infusion device 150 may provide other functions that show a variety of other displays, for example, when the last bolus was administered, when the last alarm occurred, when the last finger stick was taken, past trends, all alarms that occurred in a time period, calibrations, meals, exercise, bolus schedules, temporary basal delivery, and the like. Whenever a bolus is being delivered, the infusion device 150 can send a message every time a tenth of a unit, or some specified amount, is delivered.

**[0046]** As seen in Fig. 6A, the controller device 210, includes a housing 215 adapted to be carried by the user. A processor 212 contained in the housing 215 is adapted to process data and commands inputted by the user, and a transmitter 218 (or a transceiver 318 (as shown in Fig. 6B)) contained in the housing 215 and coupled to the processor 212 transmits such communications, including data indicative of the determined concentration of the BG in the user, to the infusion device 250. In further embodiments, the controller device 210 may be integrated with a BG meter in one housing, which has a lancing device and receptacle for BG test strips, for obtaining a BG sample from the user.

**[0047]** The controller device 210 may communicate with a remote station, such as a computer 224, through a data transfer system, using a type of communication connector 222, that couples the controller device 210 to the computer 224 and allows the data downloading. Alternatively, communication may be by wireless methods, such as RF, IR, Bluetooth or other wireless methods. Data may be downloaded via the RF telemetry in the same manner as data is transferred from the controller device 210 to the infusion pump device 250. The transmitter 218 (or a transceiver 318 (as shown in Fig. 6B)) converts RF signals into compatible electrical pulses that may be subsequently sent through a serial port to a specified destination. Data, including software upgrades and diagnostic tools, may also be downloaded via RF telemetry, or any other wireless or wired method, from a remote station, such as the computer 224, to the infusion device 250. Other remote stations include, but are not limited to, a hospital database, a cellular telephone, a PDA, a smart phone or internet. For example, a cellular phone may be used as a conduit for remote monitoring and programming. In one embodiment, the controller device may be configured so as to have cellular telephone capabilities. In further embodiments, the controller device and/or the other devices with display may be capable of providing PDA functions as well, removing the need for patients to carry separate PDA devices.

**[0048]** The controller device 210 includes on the housing a display 230 that may mimic the display on the infusion pump device 250. The controller device display 230

shows information according to communications sent to the controller device 210 from the infusion device 250. At any moment, the display of the infusion device 250 may show substantially the same information as shown on the controller device display 230. In some embodiments, whatever is shown on the infusion device 250 corresponds to that shown and reflected on the display 230 of the controller device 210. In this manner, the user may more conveniently view what is being processed or acted upon in the infusion pump device 250 without removing or adjusting the infusion pump device 250 to view the display. In embodiments, the controller device 210 may include one or more input device(s) 245, such as keys, buttons, and the like, on a keypad 265 so that all, or substantially all, viewing and data entry may be performed on the same device without moving the infusion pump device 250.

**[0049]** The infusion pump device 250 and the controller device 210 need to have substantially the same resolution or else the screen may not be presented correctly on the display. Another difficulty may be in properly displaying the scaling of graphs. This issue may be addressed by having the infusion pump device talk in an “ideal” screen, and not necessarily in its actual screen format. As shown in Fig. 7, the potential communication paths within embodiments of the infusion system are illustrated. The controller device 410 may serve as a translator between the infusion device 450 and the other components of the infusion system 400, such as a BG meter 482. For example, the controller device 410 may have the ability to determine how best to translate the infusion device’s 450 description to the screen of the two displays. As can be seen, the infusion device 450 may communicate directly with the BG meter 482. In alternative embodiments, the resolution need not be the same, and the infusion device and/or controller can compensate for the resolution difference so that one or the other may utilize enhanced displays or a simple display depending on the devices and the needs of the user.

**[0050]** In some embodiments, the infusion system 400 may include multiple controllers that can communicate with one infusion device 450. In other embodiments, there is one controller 410 communicating to one infusion device 450. The controller may also be integrated into the infusion device in some embodiments. In yet another embodiment, the BG meter 482 may be integrated into the controller 410, sharing one housing, to both communicate with the infusion pump device 450. In this embodiment, the controller is separate from the infusion pump device. In this embodiment, the infusion device 450 serves as the central hub with most of the intelligence of the system 400. In

yet another embodiment, the controller device 410 may be a key fob, in which case, the controller device 410 would serve simply as a virtual keyboard to input data and commands to the infusion device 450. Optional peripheral devices may include a physiological characteristic sensor device, such as a telemetered glucose monitoring system (TGMS) sensor. Alternatively, the sensor may be directly wired to a monitor/user interface. The TGMS sensor or physiological characteristic sensor 486 may provide for continuous BG monitoring. The physiological characteristic sensor 486 may also be linked to a bedside monitor 492 so that monitoring and programming of medication delivery may be performed remotely. In some embodiments, the infusion pump device does not include, nor need, a display. In this embodiment, a key fob may serve as a remote display. Other options for a remote display include, but are not limited to, cellular telephones, computer monitors, PDA's, smart phones, watch remotes, and the like. The infusion device 450 may further communicate with, and download data such as software upgrades and diagnostic tools from, a remote station like a computer 424 from a connector 422. Optionally, the infusion device 450 may also communicate with the controller device 410 through a station such as a cellular station 488 that includes GPS. In further embodiments, the connector 422 may have memory capability to transport data.

**[0051]** In the above embodiment, the control is maintained in the central hub and the infusion pump device 450 sends out most of the commands. The infusion device 450 also sends requests to receive specific data from the controller device 410. The controller device 410 and the infusion pump device 450 may communicate to one another by a connector 422, other wired methods or by wireless methods, such as RF, IR, Bluetooth, or other wireless methods. In other embodiments, the infusion pump device 450 may contain all or substantially all of the intelligence. The controller device 410 may be limited in the amount of time that they communicate with one another to save power in the controller device 410. For example, RF communications may be minimized, such that the marriage between the infusion pump device 450 and controller device 410 occurs once. The information regarding the screens displayed is sent to the controller device 410, and when the infusion pump device 450 needs to display a screen, it sends a screen number to the controller device 410. In the case of screen displays, if the data being sent is fixed, then the screen can be simply displayed. If the data is variable, then the variable data is sent with the screen to the infusion pump device 450. The screen is then displayed based on a combination of the fixed screen information and the variable data. Exchange IDs, strings

to be displayed, and foreign languages are among data that may be sent from the controller device 410. Further commands that may be sent from the infusion pump device 450 include, among other commands, a command to show a specific screen on the controller device 410, a command for displaying requested information on the screen, a command for showing the rules for the input devices, a command for showing the intelligence about that screen type (*e.g.*, menus, data entries, etc.), and the like. The devices may all send diagnostic information to each other, and particularly to the controller device, so that the user may see if anything is going wrong with any of the devices.

**[0052]** Fig. 8 shows an electronics architecture according to an embodiment of the invention with a custom integrated circuit (“custom IC”) 558 as the processor. This architecture can support many of the devices discussed herein, for example the controller device, the infusion device, the characteristic determining device, a BG meter, or any combination of the above. The custom IC 558 is in communication with a memory 566, keypad 565, audio devices 564 (such as speakers or audio electronic circuitry such as voice recognition, synthesis or other audio reproduction), and a display 560. Where there is a drive mechanism in a device that includes infusion functions, the custom IC 558 is in communication with a motor 552 or motor drive circuitry or other means of delivering fluids or therapy via an electro-mechanical means. Where there are one more sensors included in the device, or in communication with the device (such as a characteristic determining device or a device which includes a characteristic determining function), the custom IC 558 is in communication with the sensors 580. The electronics architecture further may include a communications block 595 in communication with the custom IC 558. The communications block 595 may be adapted to provide communication via one or more communications methods, such as RF 596, a USB 597, and IR 598. In further embodiments, the custom IC 558 may be replaced by electronic circuitry, discrete or other circuitry, with similar functions.

**[0053]** The electronics architecture may include a main battery 590 and a power control 592. The power control 592 may be adapted to give an end of battery warning to the user, which can be predicted based on the type of battery used or can be calculated from the power degradation of the battery being used. However, in certain embodiments it is not necessary to know the type of battery used to create an end of battery warning. Various battery types, such as rechargeable, lithium, alkaline, etc., can be accommodated by this design. In certain embodiments, the electronics architecture includes a removable

battery and an internal backup battery. Whenever a new removable batter is inserted, the internal backup battery will be charged to full capacity and then disconnected. After the removable battery has been drained of most of its energy, it will be switched out of the circuit and the internal backup battery will be used to supply power to the device. A low battery warning may then be issued. The internal backup battery may be rechargeable. In further embodiments, a supercap, for example, is used to handle the peak loads that the rechargeable internal battery could not handle directly, because it has sufficient energy storage. This method also allows the use of any type of removable battery (alkaline, lithium, rechargeable, etc.) and partially drained batteries. Depending on use, the backup battery may allow the device to operate for at least one day after the removable battery has been drained or removed. In further embodiments, a microprocessor measures the charge states and control switches for removable and internal backup batteries.

**[0054]** In certain embodiments, the controller device has no user settings and very little memory, because all, or substantially all, needed data and instructions will be sent to the controller device by the infusion pump device. Thus, the functions are all, or substantially all, contained on the infusion pump device in such embodiments.

**[0055]** In alternative embodiments, the infusion pump device may include expanded capabilities, such as color on the display screens, and more graph options that can present more detailed graphs. For example, there may be included a graph called "mobile day" where the BG levels of the user for the past five days may be shown as overlapping graphs. The mobile day graph allows the user to see the trend in BG level changes during those days, and aids the user in better controlling the insulin delivery according to the trends that appear for specific times of each day.

**[0056]** The BG meter may also include expanded capabilities, such as for example, voice synthesis, voice activation, polyphonic speakers for the vision impaired, and plugs on the BG meter for headphones. Likewise, the controller device may also be configured to provide these expanded capabilities.

**[0057]** As described above, the controller device may be integrated with the BG meter in some embodiments. In those embodiments, the input keys and the display will all, or substantially all, be included on the controller device. The BG meter may also be separate from the controller device and may talk directly to a sensing device, such as a TGMS sensor. The TGMS sensor is inserted into the subcutaneous tissue of the user to read body fluids, and allows for continuous blood glucose monitoring. The readings are

used in conjunction with the BG level determined by the BG meter to continuously monitor BG levels through extrapolating the BG measurements. This embodiment would be compatible with users that do not have an infusion pump device, in which case, there is a need for the ability to talk directly to the TGMS sensor without talking to the infusion pump device.

**[0058]** If the BG meter talks to the TGMS sensor then the TGMS sensor may broadcast the data received from the BG meter to the infusion pump device and the controller device. In some embodiments, the infusion pump device will always send the data to the controller device. In the case that the controller device does not receive the information from the infusion pump device, it will assume that the infusion pump device has not received the data and will communicate the value to infusion pump device. In other embodiments, the infusion pump device, controller device and TGMS sensor maintain a three-way communication with one another, and have the ability to check the contacts between one another. In still further embodiments, the system is set up to automatically call for assistance when analytes reach a certain level. The call may include a GPS location.

**[0059]** In an embodiment of the present invention, the graph displayed on the controller device may display information regarding boluses, finger sticks, exercise, meals and the like. In one embodiment, the graph displayed has eight segments, representing different limits and an actual BG line. In other embodiments, the graphs may include additional time spans for which to show the varying BG levels. For example, the embodiments may include a 3 hour, 6, 12, and 24 hour graphs. Additional features of the graphs may include the ability to zoom in or out of the graph. There may be included an ESC key that will allow the user to return to the last scale. Other options may allow the user to focus on specific positions on a graph. In yet another feature, the user can select the resolution in which to view the graph.

**[0060]** In a situation where the infusion pump device and the controller device are out of sync, *e.g.*, the graph on the pump and the graph on the controller device do not look substantially the same, there needs to be a way to resynchronize the two components if something goes wrong. For example, if finger stick values do not both have current finger stick values, then the graphs for the controller device and the infusion pump device would be different.

**[0061]** There also may be some type of positive mechanism for the controller device if the communication between the controller device and the pump are interrupted. For example, the mechanism may have the controller device stop displaying its graph in a "time-out" phase for the time the infusion pump device screen is absent or no more data is entered by the user for a period of time. In this case, the infusion pump device operates on the last data that the infusion pump device sent to the controller device to display. In an embodiment, the controller device will display an idle screen during the time-out phase and while the communication between the infusion pump device and the controller device is re-established. The idle screen may remain until the next action is selected by the user. After the time-out phase, the user may press a key to start up the communication again. Once a key is pressed, the controller device will process the key data and the screen will be displayed. The controller device may periodically send signals to the pump to see if it is still active on the screen.

**[0062]** In alternative embodiments, there will be a positive confirmation requested prior to displaying graphs. For example, the graphs may be shown in bitmap packets (*e.g.*, bit-by-bit), and if the user will be getting a large number of packets of data, for example 15 packets of data, to show the graph, the user may opt not to confirm. The data is passed from the controller device, which is programmed to display the data, to the infusion pump device. The controller device can operate in graphics description language where data is recognized by the controller device as instructing it on which position to put each line or color and the graphics display would handle determining the resolution that the graph would be displayed in. In some embodiments, the graph may be displayed in three-dimensional format.

**[0063]** The specific screens to be displayed may include fixed menus, partially variable menus, and variable menus. In fixed menus, the menus do not change depending on data. Therefore, they will always look substantially the same on the screen, and the controller device may be programmed to display them when requested. The fixed menus may be described as screen numbers. In this way, the controller device can easily request "screen 1" or "screen 2." In fixed menus, the text is defined once. There may also be menus where menu items appear and disappear depending on the current settings of the infusion pump device. These menus are considered partially variable menus because some data appear and disappear, and are not all fixed. For example, a program for bolus setup allows a user to change current bolus settings. Bolus set up menus involve variable

information as well as fixed information. The values may be variable, but the main menu items (title of variables, etc.) will stay the same. Variable menus contain information that is completely variable, *e.g.*, bolus history screen. Variable data is sent at the time of the screen display, and there is generally no fixed text. What is displayed in variable menus depend on what bolus action the user selects. The history screens resemble the menu screens in that the user cannot select and input any information with the history screen. Data entry screens, on the other hand, include multiple fields on a screen and can accept data selection and input by the user.

**[0064]** Different units may need to be switched dynamically in depending on how the type of entry is communicated. The screens may also need to be able to display minimum and maximum values as well as time increments, to ensure precision of the display. The rules for this translation will be defined in the infusion pump device. Likewise, for a dual-wave bolus, there must be defined how the values interlock. Sensor high and low BG values also need to be interlocked (in some embodiments, these two values will be displayed in the same screen).

**[0065]** In one embodiment, communication between the infusion system components takes place when the user presses one or more keys to send data to the infusion pump device and, in response, the infusion pump device can relay to the controller device to instruct on what to display. Alternatively, the user may input data through scrolling down menus and selecting options. When the user prompts, the controller device, for example by pressing an "ACT" button, the controller device will then tell the infusion pump what to do, *e.g.*, deliver fluid to the user.

**[0066]** In its most simplest form, the controller device is a display only, used to show a BG value and/or graph. In another simple form, the controller device embodies only a virtual keypad that may mimic exactly the buttons on the infusion device. When the user presses a key on the controller device, the controller device tells the infusion device what button was pressed – and the infusion device acts as if the button was pressed on the infusion device itself. Each component of the infusion system may be of different degrees of sophistication. For example, the controller device can range from a simple key fob with limited capabilities and with, for example, one or two keys to a complex device with memory, many keys and advanced graphing options. In a complex form, the controller device may embody all or substantially all of the intelligence that is present in the infusion device. In this form, the controller device could do all calculations, graphing

functions, and other data input, output, and manipulation at the controller device. The controller device would then send data to the infusion device indicating what the controller device had done so that the infusion device could be put into the same state as the controller. It is possible for the controller device to have many different degrees of computing intelligence, so that few, none, many, or all computing may be done at the controller device. How much intelligence will be in the controller device may depend on battery life, size requirements, and so forth.

**[0067]** In further embodiments, the processor of the controller device has unique identification information, and the communication transmitted from the controller device to the infusion device further includes the unique identification information of the controller device processor such that the infusion device is capable of discerning whether the communication is intended for receipt by the infusion device. In yet further embodiments, the processor of the infusion device has unique identification information, and the communication transmitted from the controller device to the infusion device further includes the unique identification information of the infusion device processor such that the infusion device is capable of discerning whether the communication is intended for receipt by the infusion device.

**[0068]** Additionally, both the controller device and the BG meter may communicate over wireless networks. Some examples include RF, IR, Bluetooth, spread spectrum communication, and frequency hopping communication. In further embodiments, there may be a "Listen Before Talk" scheme where the system selects the cleanest of allotted channels through which to communicate. Further examples include giving the controller device cellular telephone or pager capabilities. In the alternative, the communication may be wired, such as in hospital use. In a wired embodiment, there may be a tether physically connecting the infusion pump device to the controller device and/or BG meter. In yet another alternative, the controller device and the infusion pump device could be both wired and wireless—when wired, the two components communicate by wire, and when disconnected, the two components could operate through wireless communication.

**[0069]** In another wireless example, if the user has access to a computer network or phone connection, the user can open communication via the internet to obtain communications from, and send communications to, a nurse, parent, or anyone so desired. As discussed above, a transceiver may be used to facilitate data transfer between the PC

and the infusion pump device. Such a communication may also be used by a party, other than the user, to control, suspend, and/or clear alarms. This embodiment could be very useful for a parent to monitor the infusion system of a child, or for a physician to monitor the infusion system of a patient. The transceiver may allow patients at home or clinicians in a hospital setting to communicate with the various components of the infusion system via RF telemetry. The transceiver may be used to download device information from the pump and sent to the PC when the transceiver is connected in to the serial port of the PC. In embodiments, the transceiver may derive its power from the PC when the two are connected. In this way, the transceiver conveniently does not require a separate power source. In another embodiment, a cellular phone may be used as a conduit for remote monitoring and programming. In yet other embodiments, the controller device with a BG meter may also act as a transceiver, which would eliminate an extra component.

**[0070]** In further embodiments, the controller device communication system is capable of being deactivated and reactivated. The controller device may include input devices, such as keys, buttons, and the like, for inputting commands, and the communication system of the controller device is capable of being deactivated in response to a first command from the user input device and being reactivated in response to a second command from the user input device. Alternatively, the communication system of the controller device may be automatically reactivated after a predetermined amount of time has elapsed or at a predetermined time of day.

**[0071]** In an embodiment of the present invention, the processor of the infusion device uses power cycling such that power is periodically supplied to the communication system of the infusion device until a communication is received from the controller device. When a communication is received from the controller device, the processor of the infusion device discontinues using power cycling so that the power is continuously supplied to the infusion device communication system. The infusion device processor may then resume using power cycling upon completing the receipt of the communication including the data indicative of the determined concentration of the analyte in the user from a BG meter communication system.

**[0072]** In yet another embodiment, the infusion system may include a bedside monitor. The monitor could communicate through the same avenues as the BG meter, the controller device, and the infusion pump device. The monitor could be used, as described above, to remotely alarm people other than the user, such as for example, parents,

physicians, nurses, and the like. This would provide an extra layer of monitoring for the user, especially when the user is alone. In further embodiments, the system may be set up so that multiple devices are placed around the house. This would provide easy access to monitor the diabetic. Additionally, the parent will be able to obtain data to monitor a child user at home and when the parent is away. Such home monitors could be set to any mode preferred, for example, flashing lights, warning sounds like beeping, vibration, and the like. Other features may include a function that allows the remote user (parent, physician, nurse, etc.) to change and/or deliver a bolus from remote sites.

**[0073]** In an alternative, the controller device may be configured so as to have cellular telephone capabilities. The cellular network could provide a conduit for remote monitoring and programming. Additionally, the cellular network could be used to notify parents, physicians, or emergency services of alarms or alert states. A button may be included on the controller device and/or the infusion device to automatically alert a parent, physician, or emergency services when pressed. For example, a monitoring device may be built directly into a patient's cellular telephone so that in the case of a hypoglycemic event, an alarm or connection may be made to emergency services via the cellular telephone. In a further embodiment, GPS technology may also be built into the cellular telephone to allow easy location of the patient. Alternatively, GPS technology may be included in the controller device without cellular telephone technology. In other embodiments, the GPS technology may also be built into the infusion pump, BG meter or controller device.

**[0074]** The infusion system may be part of a closed-loop system, such as an implantable infusion system with a sensor system or an external infusion device with a sensor system. In such a system, there may be included safety nets, such as alarms and automatic shut-offs.

**[0075]** The alarms may be customized to specific user needs. The alarm may be set to flashing lights for the hearing impaired, or warning sounds and/or vibration for the vision impaired. There could further be included headphones that can plug into the controller device for vision impaired to instruct the user on what to do in the case that an alarm goes off. The headphones could also be plugged into a MPEG player or the like. To avoid having the pump broadcast information, the alarms may be handled in a way where the user presses a button on the controller device. Alarms could also be included on the pump. There may further be included a turn-off option where, if there is a need to

communicate with the controller, the user can choose a selection to turn off the controller. In further embodiments, there may be included a feature in any of the devices including an alarm where when the device has sounded an alarm for a period of time and the user has not responded, the alarm will switch to a vibrate mode and/or will attempt to signal companion devices in the system to alarm the user.

**[0076]** It is noted that some users can be expected to have somewhat diminished visual and tactile abilities due to the complications from diabetes or other conditions. Thus, the display and buttons or other input devices may be configured and adapted to the needs of a user with diminished visual and tactile abilities. In alternative embodiments, the high level module (and/or the low level module) may communicate to the user by audio signals, such as beeps, speech or the like.

**[0077]** Other display settings may be customizable, including, but not limited to, the background, sounds, fonts, and wallpaper. There may be a children's mode, with limited features available so that a child cannot dispense too much medication at once. Different display features may be included in the module and/or may be downloaded from a computer. The high level module may have a memory with which to store customized settings or pump control. The memory may be of any type that is known in the art, such as a volatile or non-volatile memory. Both a volatile and non-volatile memory may be used, which can speed up operation of the pump. As an example, non-volatile memories that could be used in the invention include flash memories, thumb drives and/or memory sticks such as USB thumb drives, removable hard drives, and optical drives.

**[0078]** In some embodiments, the language that the controller device operates in may comprise several different languages, ranging from 1 language to about 40 languages and potentially more. To set language, data must be first initialized to modify the phrases and detail font that may be significantly different in one language as compared to another language. For example, some languages, such as Chinese, are read in vertical columns, from the right to the left, and thus, needs to be displayed in such manner. One way to overcome this complication in using different languages is to have fonts built into the infusion pump device. Because fonts are now described in pen strokes (true-type fonts), rather than in pixels (bit-by-bit) this allows the infusion pump device to determine out how to display the different fonts. Another option could involve uploading the fonts in strings from various sources, such as the internet.

**[0079]** If so desired, a food library may be downloaded from a PC, or from the internet via a PC. In the food library, each food item will have some information associated with it, for example, carbohydrate count, fat count, proteins, serving size, and the like. The food library may be built directly into the infusion pump device, or it may be downloaded from remote sources, as discussed above. For one example, the food library may be downloaded through a transceiver embodied by the user's cellular telephone. Other options may include eliminating the need to bypass the transceiver every time a food item is selected, such as, downloading the food items from the PC and storing it until use. The food library may also be input directly into the controller device rather than the infusion pump device. If the food library is contained in the infusion pump device, an associated food library menu could be dynamic. The user could select from different layers of the food library the items consumer or about to be consumed and the infusion pump device could calculate the appropriate amount of insulin to be delivered. Variable data could be included for a small food library with less than 50 food items. For example, there could be variable data for a food library dedicated to breakfast foods only. There could be a "breakfast" key or icon on the controller device that the user can select. There may also be "lunch" and "dinner" and "snack" icons.

**[0080]** Communications between the system components may be performed in a variety of manners. In an embodiment using RF options, there could be employed a single frequency or a "spread spectrum" where a large range of RFs can be used to relay the communication. In another embodiment, changing frequencies can be used so as to pick up whatever frequency is present. This is known as "frequency hopping," where the frequency changes every millisecond or so to take advantage of all, or substantially all, frequencies available. In some cases, frequency hopping allows the system to find frequencies that are not being used by other nearby systems and thus avoid interference. In addition, a system may operate in a manner where each component-to-component communication is on a different frequency, or where the delay for each communication is different. Other types of RF, that are not described, may also be used for communication, such as, translation frequency.

**[0081]** According to yet another embodiment of the present invention, an infusion system includes a controller device, with a controller device display, and an infusion device, with an infusion device display, and a method for infusing a fluid into a body of a user is provided. The method includes the steps of: receiving data communication from a

user, transmitting with the controller device the communication including data to an infusion device, receiving with the infusion device the communication, and displaying with the controller device display information regarding the fluid delivery, where the display on the controller device display shows information according to instructions or communications sent to the controller device from the infusion device. At any moment, the display of the infusion device may correspond with what is displayed on the infusion device display. The method may further include the step of displaying a trends and graphs. Additionally, the method may include the step of inputting an estimate of a material to be ingested by the user, and the estimated amount of fluid to be infused into the body of the user is calculated further based upon the inputted estimate of the material to be ingested by the user.

**[0082]** Although the above description has been focused on use of a controller device with an infusion device, it is appreciated that a controller device as described herein could be used with any number of therapy/diagnostic devices. For example, in any case where a therapy/diagnostic device is tethered to the body, at least partially implanted in the body, or otherwise inconvenient for the user to manipulate while therapy or diagnosis is being performed, a controller device may be used that can send commands to the therapy/diagnosis device and/or mimic the display on the therapy/diagnosis device. Therapies other than infusion of fluids could include electrical therapy, such as electrical therapy for the brain and for conditions such as epilepsy. Diagnostics could include any number of diagnostics, such as information from cardiac and other sensors.

**[0083]** Electrical therapy devices include neurostimulation devices for epilepsy, similar devices for pain management, etc. In addition, there are electro-acupuncture devices, where a needle is inserted into the body much like acupuncture, but additional therapy is delivered by electrical impulses. In certain embodiments, the structure of an electrical therapy device may include a needle that is inserted into appropriate areas of the body. The architecture would be similar to that of the devices described above. The patient/user would use the controller device to deliver “dosages” of electrical impulses to alleviate pain and manage neurological symptoms on demand such as twitching, uncontrolled movement of limbs, spasms, and so forth.

**[0084]** In further embodiments, devices such as those used in physical therapy clinics could be adapted for individual use. For example, a patch or other device placed on the body could be activated by the controller device to delivery said therapy, be it

ultrasound, heat or some other media. The architecture for these devices could be similar to the architecture of the devices already described, where a physiological characteristic sensor or infusion device is replaced by a therapy delivering device/mechanism.

**[0085]** In further embodiments, the controller device is part of a time-telling device, for example, a watch. A watch may be considered a more socially acceptable embodiment of a controller device, because it is common for people to wear watches, making it less noticeable that a user is using an infusion pump and/or analyte monitor. Because watches beep or otherwise alarm, it is less noticeable when a watch alarms to indicate high or low glucose, infusion pump occlusion, or other alarm occurrences. The watch controller device may have the same functionality as the embodiments discussed above. As discussed above, the watch controller device may interact with one or more devices, such as infusion pumps and analyte monitors. Figs. 9A and 9B show an alternative embodiment of a combined watch and controller device 900 according to an embodiment of the present invention. Fig. 9A shows a front view of a watch controller device and Fig. 9B shows a rear view of a watch controller device. The watch controller device 900 includes a housing 905 adapted to be worn or carried by the user and a communication system (not shown) contained in the housing 905 for transmitting a communication or command from the user to the infusion device or analyte monitor. The housing 905 may include a transparent member 950 on the front side over a display 910. The transparent member 950 may be made of any material, such as glass or plastic, that allows for viewing the display beneath the transparent member 950. The housing may also include a cover 960 on the rear side that will allow for removal of a battery or other maintenance on the device. The watch controller device may include one or more input devices 925a, 925b, 925c, 930 on the controller device housing, such as keys, buttons or the like, for the user to input data or commands. In the embodiment shown, there are keys/buttons 925a, 925b, and 925c and scroll wheel 930. The scroll wheel 930 may also be the type of wheel that may be depressed or moved outward to input different types of commands. The watch controller device 900 may include a wrist band 940 so that a user may wear the watch controller device 900 on his/her wrist.

**[0086]** The watch controller device 900 further includes a display 910 on the controller device housing 905 that is adapted to display a time 920. The display of the time 920 may be digital or analog. For example, the time may be shown by an analog display using traditional watch hands. In further embodiments, the date may also be

shown. The time may be changed by the user using the keys/buttons 925a, 925b, 925c or scroll wheel 930, depending on the setup of the watch controller device. The display 910 also may display at least a portion of whatever information and/or graph is being displayed on the infusion device display or on the analyte monitor display. This display may also be digital or analog. For example, a traditional watch hand may be used to indicate levels of glucose. In a simplified version, the hand merely goes from low blood glucose values, through target blood glucose values, to high blood glucose values. The target range could be set by the user. There may be numbers to indicate the actual level of blood glucose and/or the hand could move through a red-yellow-green-yellow-red type color arc, where red indicates that the user has exceeded a blood glucose threshold (high or low), yellow indicates that the user is coming up on a blood glucose threshold, and green indicates that the user's blood glucose is within the target range. Other colors and numbers of colors could be used as well. If the watch controller device 900 is interacting with a glucose sensor or an infusion pump that stores glucose values, the display may show just glucose values and optionally trending of glucose values. In the embodiment shown in Figure 9, the display 910 displays digital glucose values 915 and trending arrows 918. Trending may be shown by arrows, for example, if glucose values have been rising for a certain amount of time or measurements, an up arrow may be displayed. In further embodiments, the display is a touchscreen display that may be activated by a user's hand, stylus, or other implement. In still further embodiments, the user may input commands by voice.

**[0087]** The display of the watch controller device may display data directly from a pump, with or without sensor augmentation, and/or analyte sensor monitors.

Alternatively, data may be received directly from a sensor transmitter on the patient's skin. The display may show any number of representations of data from the infusion device and/or analyte sensor monitor, such as basal rate, whether or not a user is currently receiving a bolus, amount of the bolus, time left for the bolus, type of bolus (e.g., square wave), last alarm or last few alarms, time until the next bolus. The display may display alerts to the user, such as "do you want to take a bolus?" The display may display what the user is inputting to transmit to the infusion device or analyte sensor monitor. For example, if the user is changing the basal rate, the display may show the basal rate numbers being manipulated by the user. As discussed above, the display may also mimic the display on the infusion device.

**[0088]** As seen in Fig. 10, the watch controller device 1010, includes a housing 1015 adapted to be carried by the user. A processor 1012 contained in the housing 1015 is adapted to process data and commands inputted by the user, and a transmitter/transceiver 1018 contained in the housing 1015 and coupled to the processor 1012 transmits such communications, including data indicative of the determined concentration of the BG in the user, to the infusion device 1050. The processor 1012 is also in communication with a timer 1016, which is adapted to tell time so that the watch controller device 1010 may act as a watch. In further embodiments, the controller device 1010 may be integrated with a BG meter in one housing, which has a lancing device and receptacle for BG test strips, for obtaining a BG sample from the user. In still further embodiments, the transceiver 1018 receives information from an analyte sensing device 1060. The analyte sensing device 1060 may be adapted to receive data from a sensor, such as a transcutaneous sensor.

**[0089]** In general, the electronics of the watch controller device 1010 are the same as the electronics described above with respect to the generic controller device. For example, the watch controller device 1010 may communicate with a remote station, such as a computer 1024, through a data transfer system, using a type of communication connector 1022, that couples the watch controller device 1010 to the computer 1024 and allows the data downloading. Alternatively, communication may be by wireless methods, such as RF, IR, Bluetooth or other wireless methods. Data may be downloaded via the RF telemetry in the same manner as data is transferred from the watch controller device 1010 to the infusion pump device 1050. Data, including software upgrades and diagnostic tools, may also be downloaded via RF telemetry, or any other wireless or wired method, from a remote station, such as the computer 1024, to the infusion device 1050. Other remote stations include, but are not limited to, a hospital database, a cellular telephone, a PDA, a smart phone or internet. For example, a cellular phone may be used as a conduit for remote monitoring and programming.

**[0090]** The watch controller device 1010 includes on the housing a display 1030 that may mimic the display on the infusion pump device 1050. The controller device display 1030 shows information according to communications sent to the watch controller device 1010 from the infusion device 1050. The display 1030 of the watch controller device also shows the current time, as a watch would show. The display of the current time may be in digital format or analog format. The display 1030 of the watch controller device may also display a timer, such as a stopwatch would display. In embodiments, the

controller device 1010 may include one or more input device(s) 1045, such as keys, buttons, and the like, on a keypad 1065 so that all, or substantially all, viewing and data entry may be performed on the same device without moving the infusion pump device 1050.

**[0091]** The watch controller device 1010 may include a memory 1014 to store data. The memory 1014 may also store controller programs that may be processed by the processor to control the infusion pump 1050 and/or analyte sensing device 1060. The memory may be of any type that is known in the art, such as a volatile or non-volatile memory. For example, the memory may be a semiconductor memory. Both a volatile and non-volatile memory may be used, which can speed up operation of the pump. As an example, non-volatile memories that could be used in the invention include flash memories, thumb drives and/or memory sticks such as USB thumb drives, removable hard drives, and optical drives.

**[0092]** As discussed above, alarms may be provided for a number of desired conditions. For example, alarms or other alerts may be provided when a user's glucose level is approaching a predefined threshold, or has exceeded a predefined threshold, which may indicate that a user is approaching hypo- or hyper-glycemia. An alarm may be triggered by change in trends of analyte levels or by the current value of an analyte level. The alarm may indicate that an occlusion has occurred in a pump or that the syringe portion of a syringe-type infusion pump is not seated properly. The alarm may be an audio, visual, and/or tactile alarm. For an audible alarm, such as beeping, the alarm may get increasingly louder. For a tactile alarm, such as a vibration, the alarm may get increasingly stronger and/or faster. For a visual alarm, such as flashing or changing of color or indication of an alarm by an icon, the alarm may get increasingly brighter, faster, and/or larger. In further embodiments, the alarm is a personalized voice alarm, in which a parent, physician, caretaker, or other person may record a warning that plays upon activation (e.g. "your blood glucose is low," "you need to take a bolus," etc.).

**[0093]** Like the embodiments of the controller device discussed above, the watch controller device may be a display, an interface through which commands can be sent to an infusion device, sensing device, or other device, or both. For example, if the controller device is acting as an interface, the user may administer a bolus or may adjust other settings in the infusion pump or other device. The controller device may be a conventional watch design, with one or more inputs, such as buttons, on the side and/or on the face of

the watch. The inputs could also be scroll wheels, multi-directional navigation inputs, such as 5-way inputs, and touch screens.

**[0094]** In further embodiments, as discussed above, a BG meter may be integrated into the controller device housing, where the watch controller further includes a BG meter receptacle. The watch controller device thus may receive and test the BG level from a blood sample of a user.

**[0095]** In further embodiments, the controller device is adapted to receive additional information about a patient. For example, the controller device may monitor heart rate or and/or metabolic rate, as in an exercise monitor. In further embodiments, the heart rate or metabolic rate may be correlated to a level of exercise, such as low, medium or high, to store in the controller device memory, infusion pump memory, analyte monitor memory, and/or other device memory. A controller device, especially one that is worn on the skin, like a watch, may further be adapted to monitor the patient's temperature, salinity (from sweat), ketones, or other characteristic. The controller device may be adapted to measure further characteristics, such as alcohol content of blood, as in a breathalyzer, ketones, and/or lactose. Further example characteristics that may be monitored by the controller device are discussed above.

**[0096]** The watch controller device may monitor analytes such as blood glucose levels. A sensor needle may be adapted to couple to the watch controller device to sense blood glucose levels. The current detected in the sensor would be read by the watch controller device and could be converted to glucose measurements at the watch controller device or at another device.

**[0097]** The watch controller device may further be adapted to include cellular phone, PDA and/or smart phone capabilities. The watch controller device may be adapted to store audio and visual files, such as mp3 files. The watch controller device may include an earphone jack or other sound interface, such as a speaker, to allow sound output of alarms and/or for any media files that might be stored in embodiments allowing storage of media files. The watch controller device may have internet capability, so that a user could browse the internet directly from the watch controller device.

**[0098]** While the embodiment shown in Figs. 9A and 9B shows a wrist-worn device as the watch-type controller device, a watch-type controller device may be adapted to be worn on another part of the body or clothing of a user. For example, the watch may be worn on a watch fob, key chain, necklace, belt, ankle, or in a pocket of a user. In

certain embodiments, the watch controller device is adapted to work as a traditional watch and tell time. However, it is not necessary that the watch controller device tell time. The watch controller device may be configured to be a stopwatch as well.

**[0099]** In embodiments in which the watch controller device tells time, the controller device may be synched to the global atomic clock to ensure that the time is accurate. It may be useful to have the controller device synched to the device(s) it is controlling and/or monitoring, for example an infusion pump or an analyte monitor. The controller device may have the master clock, by which all other devices are synched. Alternatively, one of the other devices could have the master clock that synchs the controller device. The synchronization could be transmitted by the same method that the one or more devices is connected to the controller device. It may also be by a pager network. By synching all devices, it is possible to reduce confusion on data reporting from potentially mismatched events in a database that contains information from the devices. For example, if an insulin infusion pump thinks the time is 12PM and glucose sensor thinks it is 1PM, any glucose measurement will be an hour later than the corresponding infusion rates, which would make analysis of data inaccurate. In further embodiments the controller device is adapted to alarm when times of devices are not in synch.

**[00100]** As discussed above, the battery in the watch controller device may be a single use or rechargeable battery. There may a connector or other interface on the controller device to attach the device to an electrical outlet, docking station, portable recharger, or so forth to recharge the battery while in the device. It is also possible that the rechargeable battery may be removable for recharging outside the housing. The battery may be a kinetically charged battery or a solar or quasi-solar cell battery. It may be a readily available battery, such as a coin cell battery. In addition, there may be a rechargeable battery and an additional battery in case of battery failure or other need.

**[00101]** As discussed above, transmission between the controller device and the infusion device, sensor, or other device may be wired or wireless, such as RF, infrared (IR), Bluetooth, ZigBee, and other 802.15 protocols, 802.11 WiFi, spread spectrum communication, and frequency hopping communication.

**[00102]** The display of the watch controller device may be configured in any of the configurations discussed above. It may have a digital format, showing time and/or readings from the controlled/monitored devices in digital form. It may have graphical

representations of time, etc. The display may be color or black and white. The display may have backgrounds that can be customized by the user (e.g., a number of displays are stored, among which the user may choose) and/or downloaded by the user. The display may be icon-based so that it may be easily used by different language speakers. The display may also be set up to use a variety of languages, which may be stored in the controller device, e.g. 3, 5, 10, 15, 17, 22 or any other number of languages to about 40 languages and potentially more. Other display settings may be customizable, including, but not limited to, the background, sounds, fonts, and wallpaper. There may be a children's mode, with limited features available so that a child cannot dispense too much medication at once.

**[00103]** The sounds of the controller device may also be customizable, including, but not limited to sounds for alarms, key input, and alerts. Different audible features may be included in the module and/or may be downloaded from a computer.

**[00104]** In a watch controller device, there may be different aesthetic appearance options. For example, a watch controller device worn on a wrist, with a wrist band, may have different bands or different colors and/or materials, such as cloth or metal and plain or patterned colors. The watch itself may have a backlight or different colored lighting and/or displays. The different colors may be used to indicate different alerts or alarms. Configurable graphics may be included for the display, such as selectable font size (e.g., a larger font size for vision impaired users).

**[00105]** While the input for the watch controller device, such as buttons, have been described as included on the watch housing, in further embodiments, a watch band may have inputs, such as buttons, to expand the interface. The watch controller device may also include an antenna, for example on a watch band.

**[00106]** In further embodiments the controller device may include a medical alert display on the display or a medical alert on another part of the housing, to indicate a condition, such as an allergy or disease, that should be alerted to medical professionals and others who may have to care for the user.

**[00107]** While the description above refers to particular embodiments of the present invention, it will be understood that many modifications may be made without departing from the spirit thereof. The accompanying claims are intended to cover such modifications as would fall within the true scope and spirit of the present invention.

**[00108]** The presently disclosed embodiments are, therefore, to be considered in all respects as illustrative and not restrictive, the scope of the invention being indicated by the appended claims rather than the foregoing description. All changes that come within the meaning of and range of equivalency of the claims are intended to be embraced therein.

**WHAT IS CLAIMED IS:**

1. A watch for controlling an infusion pump, comprising:
  - a housing including a transparent member on the front side and a cover on the rear side;
  - a display under the transparent member to display an indication of a time of day;
  - a controller device within the housing, the controller device including:
    - a transmitter adapted to transmit information to an infusion device; and
    - a receiver adapted to receive information from the infusion device.
2. The watch of claim 1, wherein the display is constructed to display a digital representation of the time of day.
3. The watch of claim 1, wherein the display is constructed to display an analog representation of the time of day.
4. The watch of claim 1, further comprising one or more input elements on the housing.
5. The watch of claim 4, wherein the one or more input elements are each independently selected from the group consisting of buttons, scroll wheels, touch screens, and voice input devices.
6. The watch of claim 1, further comprising a wrist band attached to the housing and adapted to be worn on the wrist of a user.
7. The watch of claim 6, further comprising one or more input elements on the wrist band for providing inputs to the watch.
8. The watch of claim 1, wherein the housing is adapted to be worn by the user in a configuration selected from the group consisting of on the clothing of the user and in the pocket of the user.
9. The watch of claim 1, wherein the controller device further includes a processor within the housing adapted to process the information from the infusion device.
10. The watch of claim 1, wherein the receiver and transmitter are integrated in a transceiver.
11. The watch of claim 1, wherein the information transmitted to the infusion device includes instructions for acts to be performed by the infusion device.

12. The watch of claim 1, wherein the controller device includes a processor adapted to cause the display to display a representation of at least a portion of the information received from the infusion device.
13. The watch of claim 1, wherein the controller device includes a processor adapted to cause the display to display a screen corresponding to a screen displayed by the infusion device.
14. The watch of claim 1, wherein the receiver is further adapted to receive information from an analyte sensing device.
15. The watch of claim 14, wherein the analyte sensing device is a blood glucose meter.
16. The watch of claim 14, wherein the analyte sensing device is a continuous glucose sensor.
17. The watch of claim 14, wherein the information received from the analyte sensing device includes data representing an analyte level of the user.
18. The watch of claim 17, wherein the display is adapted to display a representation of the analyte level of the user.
19. The watch of claim 17, wherein the display is adapted to display a representation of a trend of the analyte level of the user.
20. The watch of claim 17, including an alarm adapted to activate when the analyte level of the user meets a predetermined threshold.
21. The watch of claim 20, wherein the alarm is at least one of a visual alarm, an audible alarm, and a tactile alarm.
22. The watch of claim 21, wherein the alarm is a personalized voice alarm.
23. The watch of claim 17, adapted to automatically contact an emergency response system if the determined concentration of the first analyte meets a predetermined threshold.
24. The watch of claim 23, further adapted to transmit a global positioning signal to the emergency response system.
25. The watch of claim 1, wherein the receiver is adapted to receive information from a heart rate monitor.
26. The watch of claim 1, wherein the processor is adapted to correlate the information from the heart rate monitor to a level of exercise.

27. The watch of claim 1, further comprising a characteristic sensor connected to the housing to measure one or more characteristics of the user.
28. The watch of claim 27, wherein the one or more characteristics are selected from the group consisting of blood alcohol level, ketone level, hormone level, cholesterol level, oxygen level, pH level, and lactate level.
29. The watch of claim 1, wherein the display includes a backlight.
30. The watch of claim 1, wherein the display is constructed to display graphics configurable by the user.
31. The watch of claim 1, wherein the display is constructed to display words in one or more languages, selected from a number of languages stored in the combined watch and controller device.
32. The watch of claim 1, wherein a receptacle is formed in the housing and adapted to receive a fluid from a user, wherein the controller device includes a processor adapted to test the fluid to determine a concentration of a first analyte in the user.
33. The watch of claim 32, wherein the display is adapted to display a representation of the determined concentration of the first analyte.
34. The watch of claim 33, wherein the first analyte is blood glucose.
35. The watch of claim 1, wherein the infusion device is an insulin infusion pump.
36. The watch of claim 1, wherein the display switches to an idle screen when no communication is received from the infusion device for a period of time.
37. The watch of claim 1, wherein at least one of the transmissions from the transmitter and to the receiver is a wireless transmission.
38. The watch of claim 37, wherein the wireless transmission is sent by a wireless method selected from the group consisting of radio frequency, infrared, ZigBee and Bluetooth.
39. The watch of claim 37, wherein the wireless transmission is sent by a wireless method selected from the group consisting of single frequency communication, spread spectrum communication, and frequency hopping communication.
40. The watch of claim 1, wherein the receiver is further adapted to receive information downloaded from a remote station.
41. The watch of claim 40, wherein the remote station is selected from the group consisting of a computer, a hospital database, a cellular telephone, a personal digital assistant, remote location over the Internet, and a smart phone.

42. The watch of claim 1, wherein the housing is water resistant.
43. The watch of claim 1, further including a memory for storing data.
44. The watch of claim 43, wherein the memory is a semiconductor memory.
45. The watch of claim 1, further including a memory for storing control programs and a processor for processing the stored control programs.
46. A method of controlling an infusion device comprising:  
transmitting information to an infusion device from a watch, wherein the watch includes:  
a housing including a transparent member on the front side and a cover on the rear side;  
a display under the transparent member to display an indication of a time of day; and  
a controller device within the housing, the controller device including:  
a transmitter adapted to transmit information to the infusion device,  
and  
a receiver adapted to receive information from the infusion device receiving information from the infusion device at the watch.
47. The method of claim 46, further comprising displaying a representation of at least a portion of the information received from the infusion device on the display.
48. The method of claim 46, wherein the information transmitted to the infusion device includes instructions for acts to be performed by the infusion device, whereby the infusion device acts in response to the instructions.
49. The method of claim 46, further comprising displaying a screen on the display in response to receiving the information from the infusion device, wherein the screen is substantially the same as a screen being displayed by the infusion device.
50. The method of claim 46, comprising displaying a digital representation of the time of day on the display.
51. The method of claim 46, comprising displaying an analog representation of the time of day on the display.
52. The method of claim 46, wherein the watch further includes one or more input elements on the housing.

53. The method of claim 52, wherein the one or more input elements are each independently selected from the group consisting of buttons, scroll wheels, touch screens, and voice input devices.
54. The method of claim 52, further comprising receiving instructions from the input elements.
55. The method of claim 54, further comprising transmitting the instructions received from the input elements to the infusion device.
56. The method of claim 46, wherein the watch further includes a wrist band attached to the housing and adapted to be worn on the wrist of a user.
57. The method of claim 46, wherein the watch further comprising one or more input elements on the wrist band for providing inputs to the watch.
58. The method of claim 46, wherein the housing of the watch is adapted to be worn on the clothing of a user.

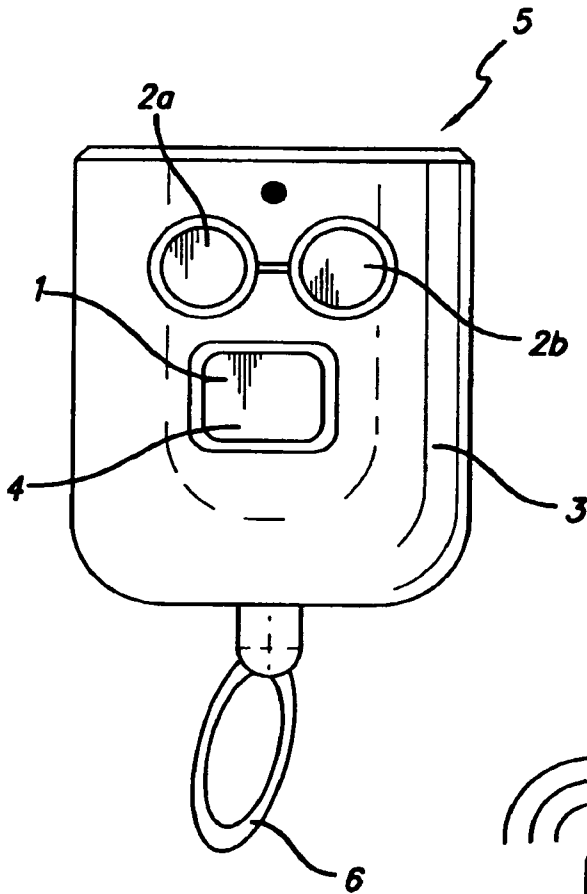

FIG. 1

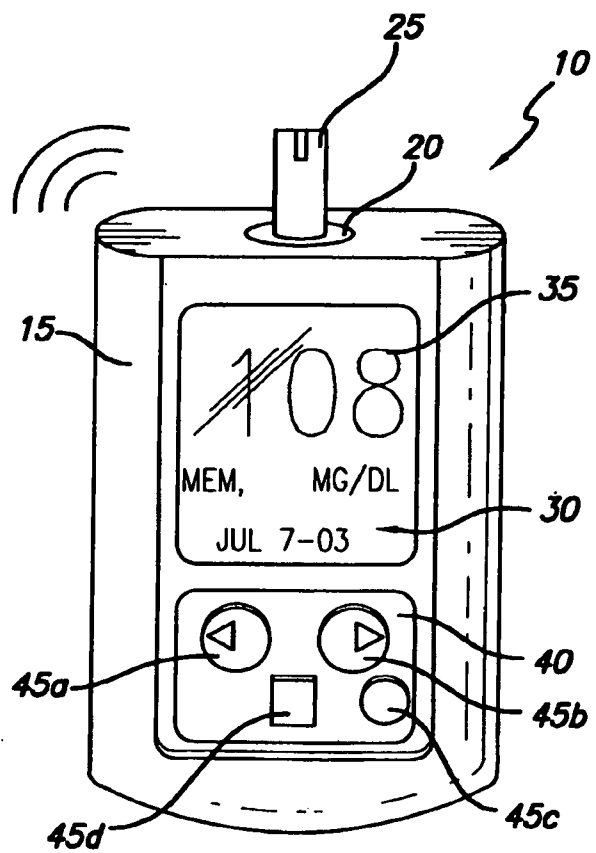

FIG. 2

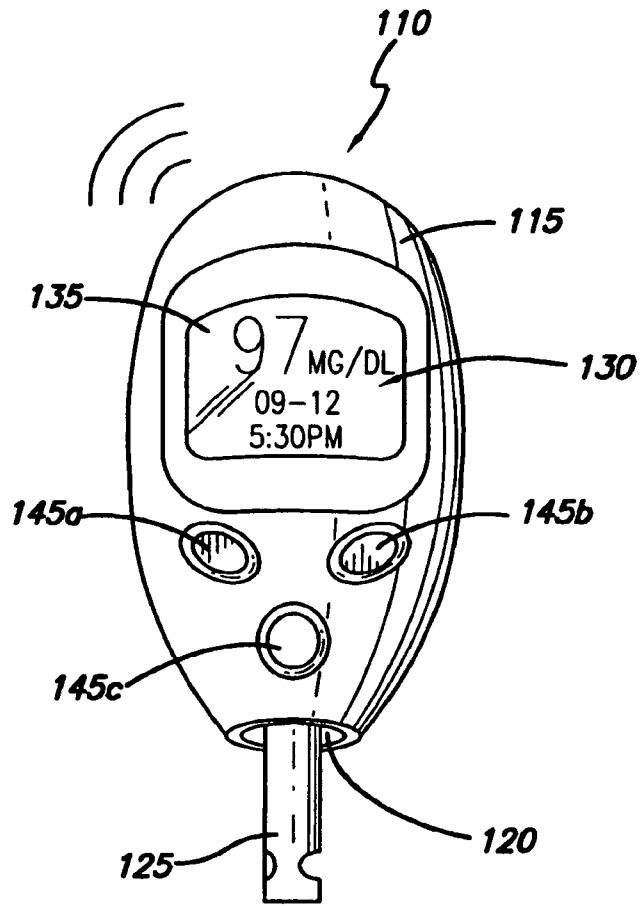

FIG. 3

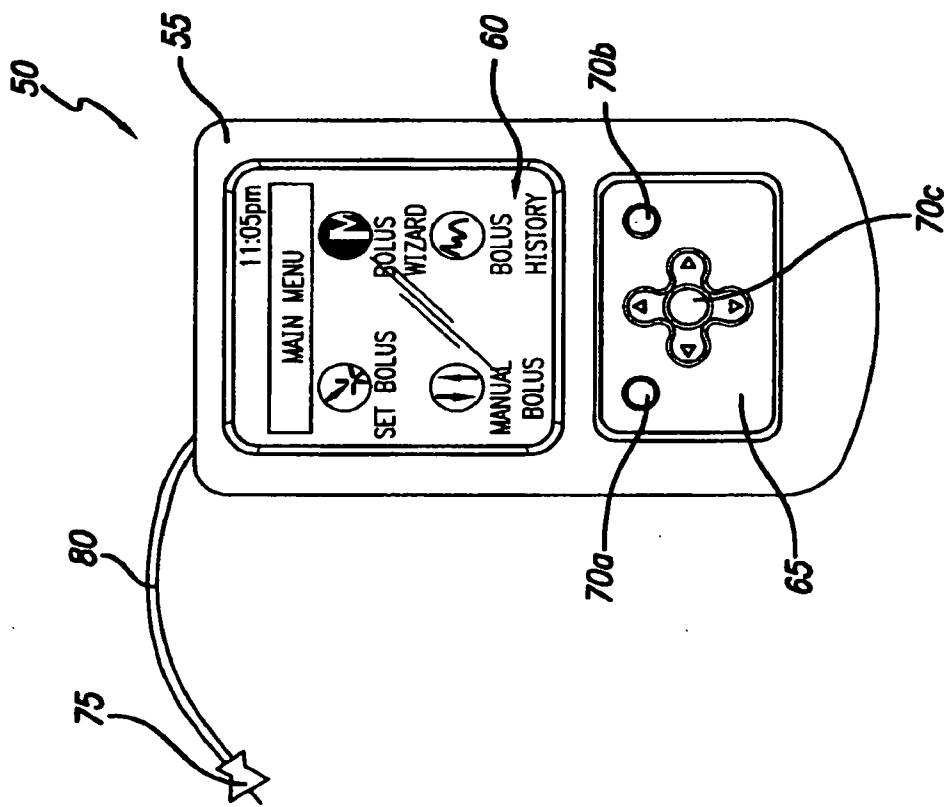
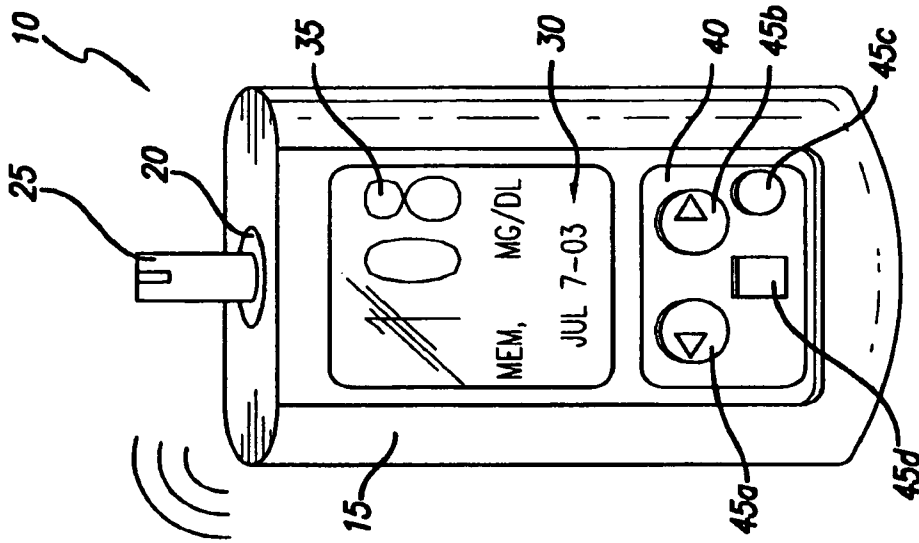

FIG. 4

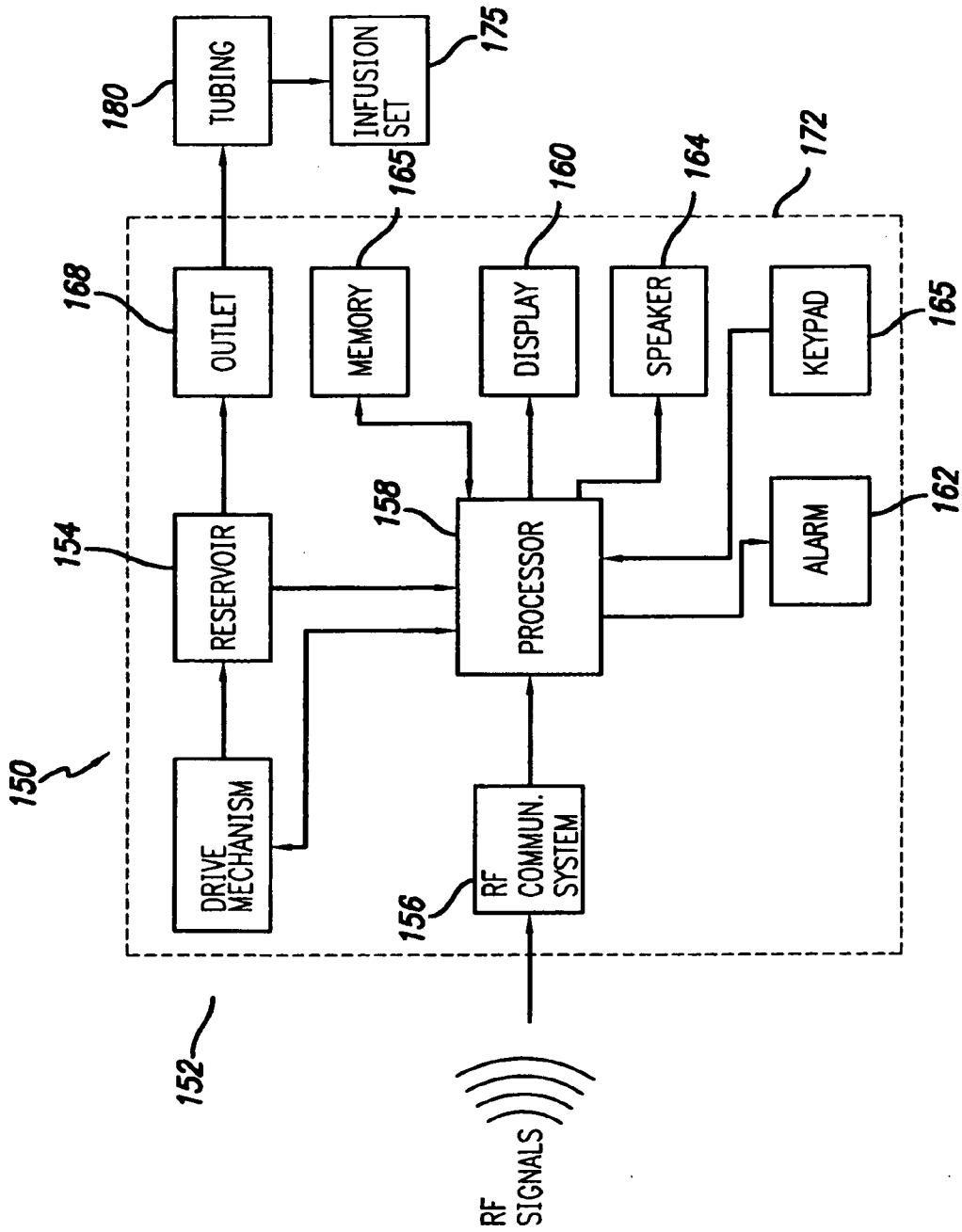

FIG. 5

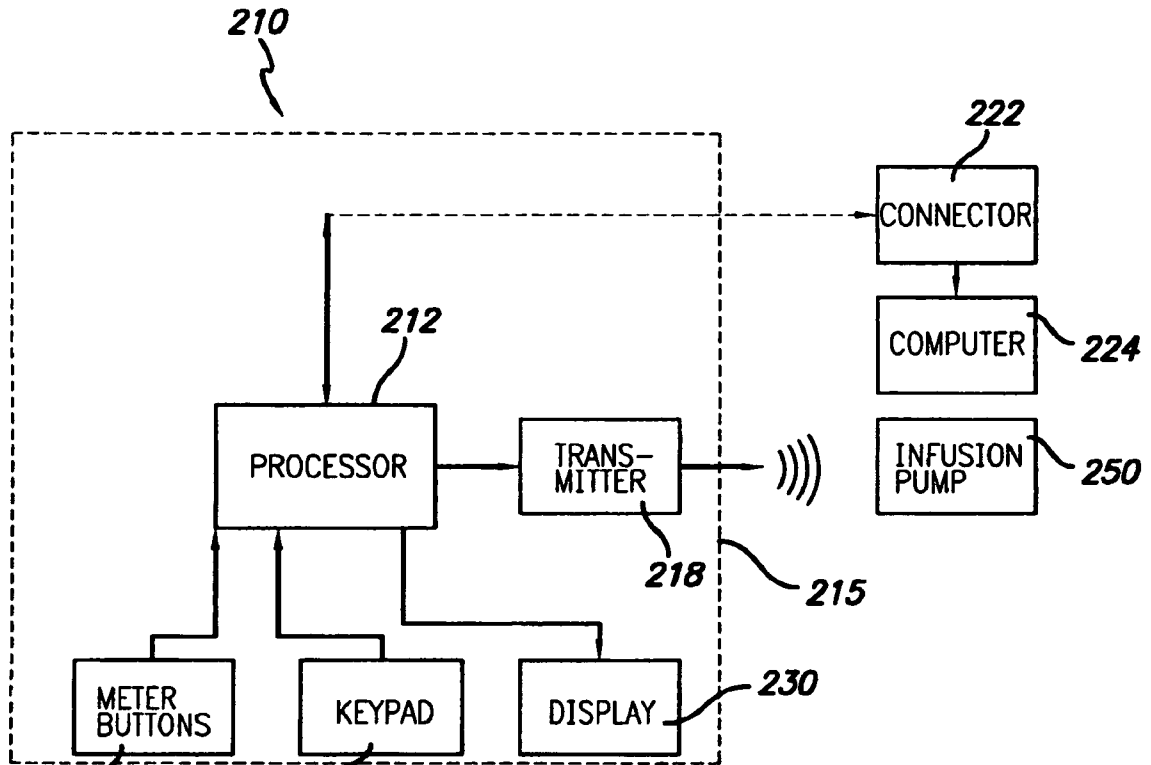

FIG. 6a

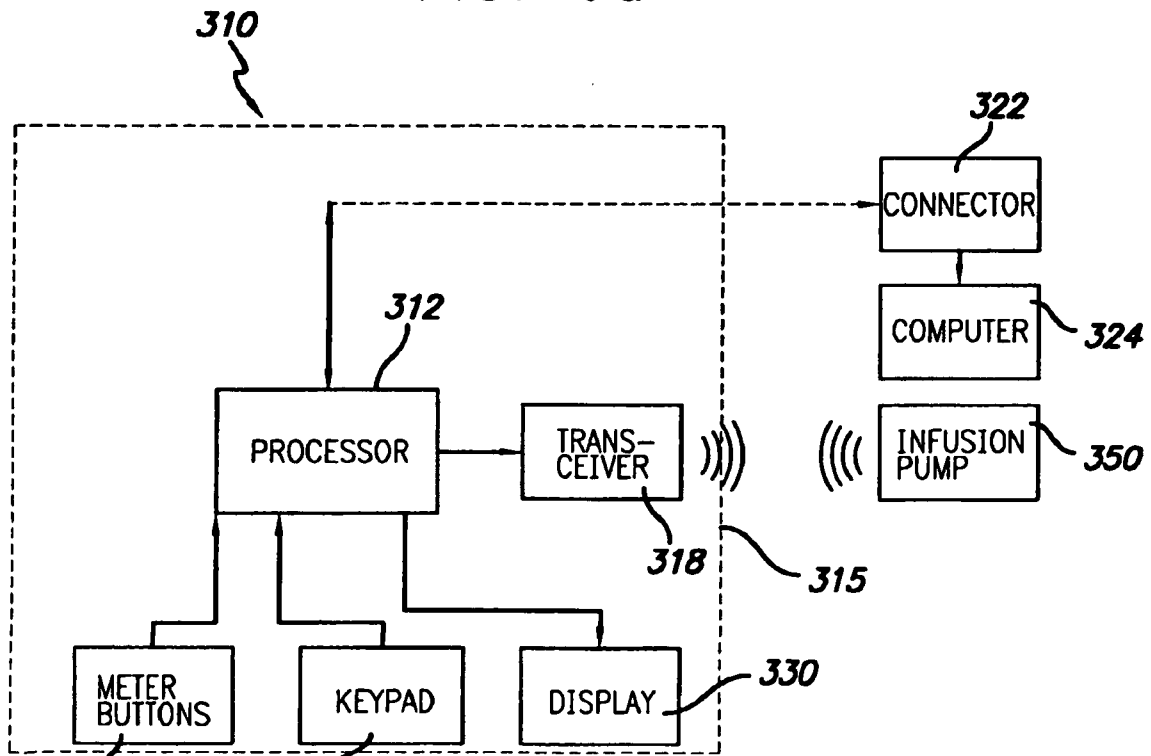

FIG. 6b

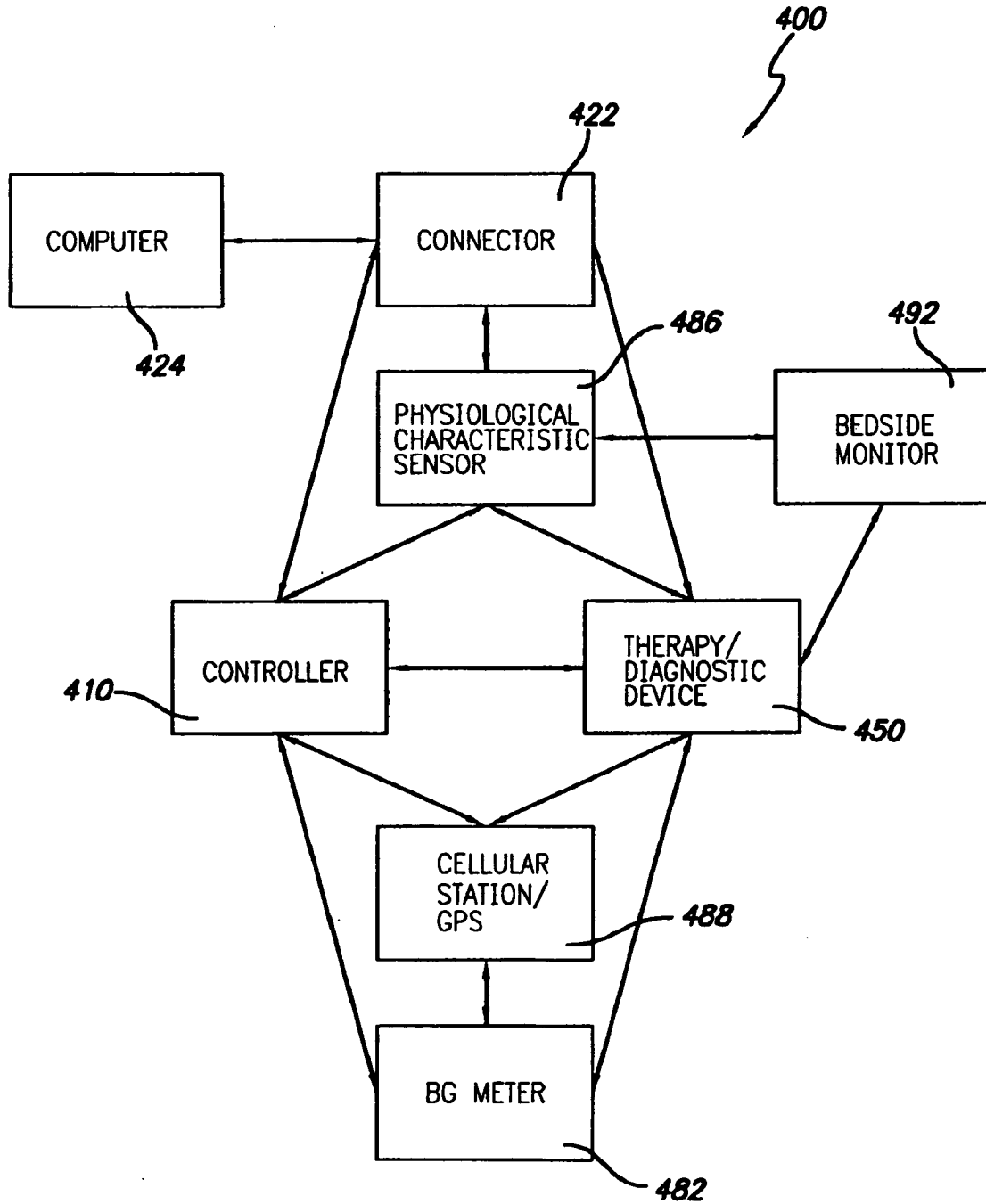

FIG. 7

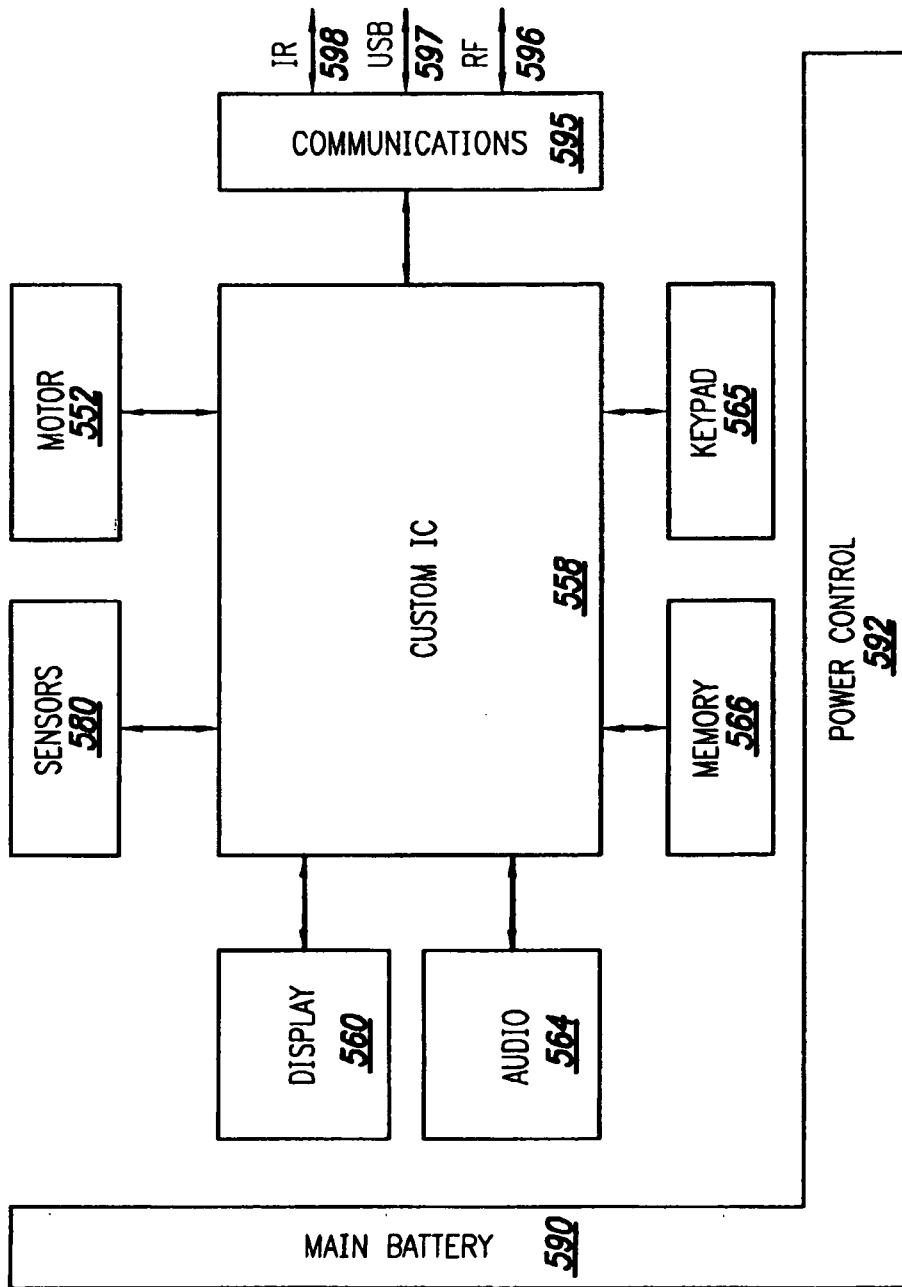

FIG. 8

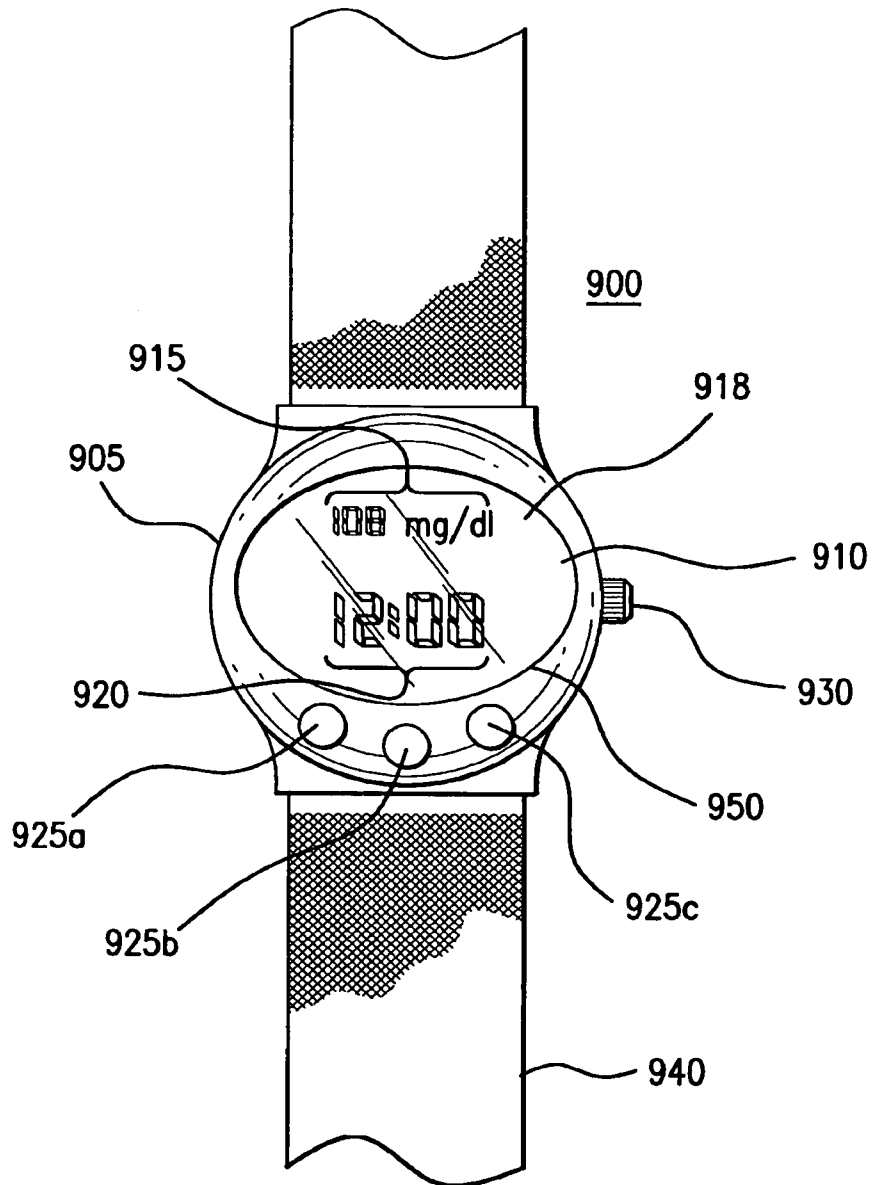

FIG. 9A

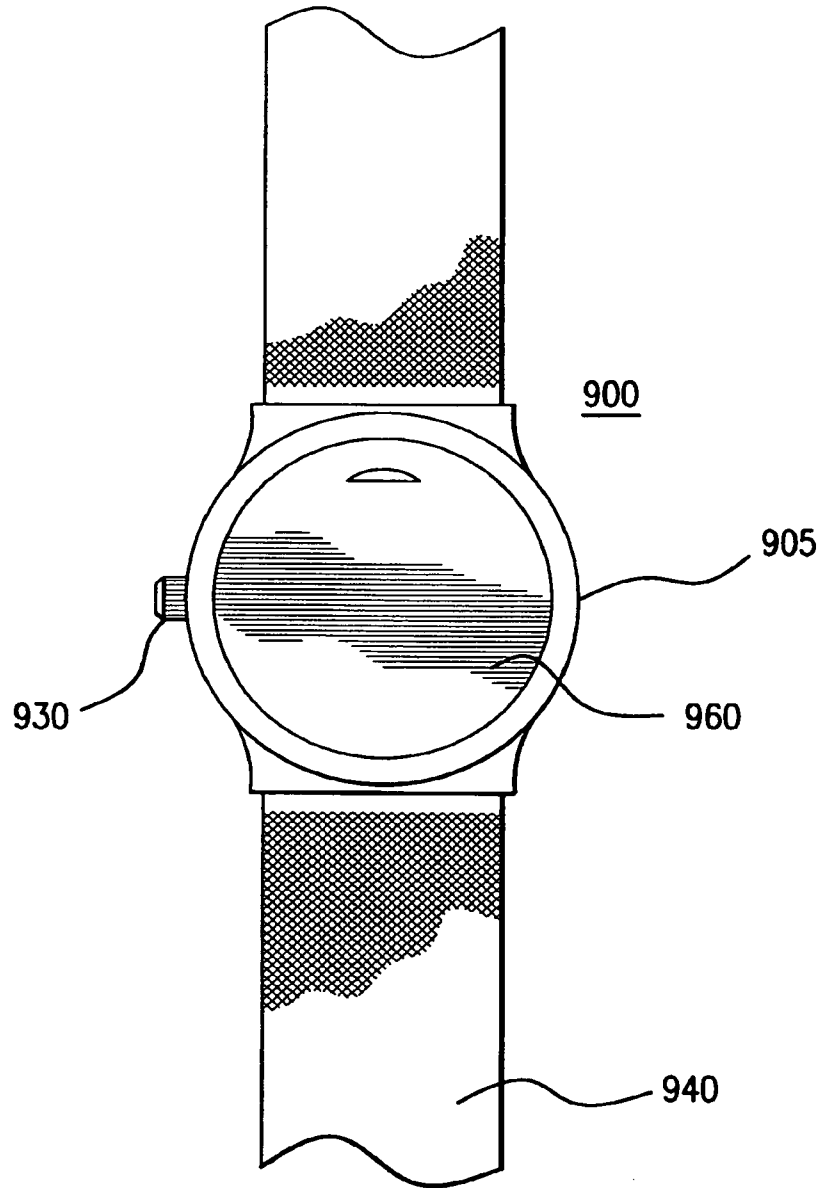

FIG. 9B

FIG. 10

