

Feb. 10, 1925.

1,525,544

J. HORRIDGE

MACHINE FOR COMBING COTTON WOOL AND THE LIKE

Filed Feb. 12, 1924

FIG 1

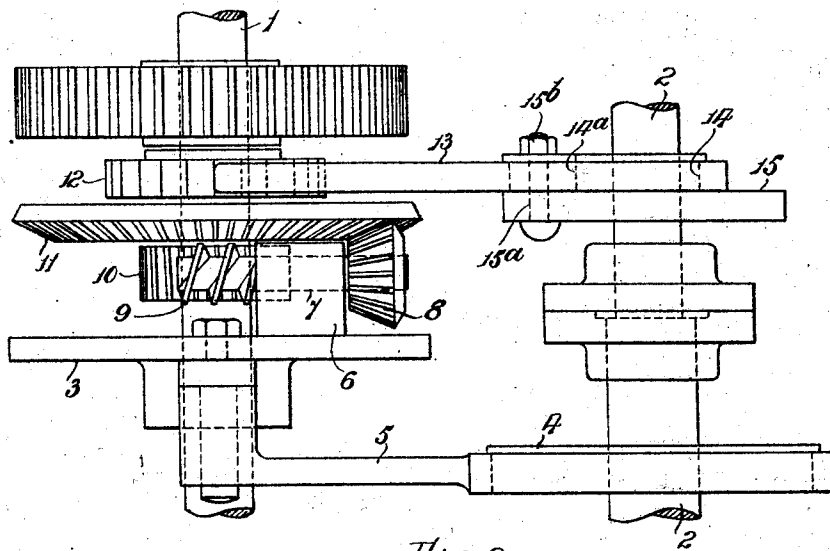
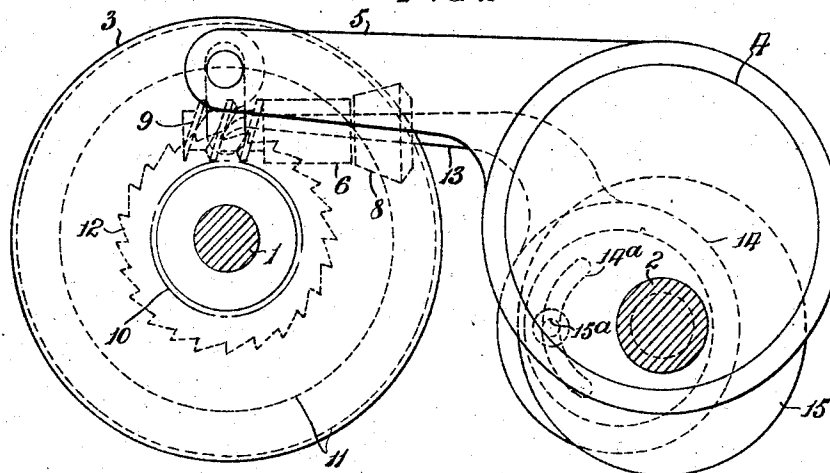

FIG 2



INVENTOR.  
JAMES HORRIDGE  
BY Francis E. Boyce  
ATTORNEY

# UNITED STATES PATENT OFFICE.

JAMES HORRIDGE, OF BOLTON, ENGLAND, ASSIGNOR TO JOHN HETHERINGTON AND SONS LIMITED, OF MANCHESTER, LANCASTER, ENGLAND.

MACHINE FOR COMBING COTTON WOOL, AND THE LIKE.

Application filed February 12, 1924. Serial No. 692,446.

*To all whom it may concern:*

Be it known that I, JAMES HORRIDGE, a subject of the King of Great Britain, residing at Bolton, in the county of Lancaster, England, have invented new and useful Improvements in or Relating to Machines for Combing Cotton Wool, and the like, of which the following is a specification.

The invention relates to improvements in or relating to machines for combing cotton, wool and the like and is an improvement upon the invention described in the specification of my application for Letters Patent No. 636,817 filed the 5th day of May 1923.

In that specification was described gear for imparting a partial reverse and forward motion to the front detaching rollers in which a ratchet wheel and catch were employed to stop the rotation of a gear wheel at certain times and the catch was mounted upon the cylinder shaft.

Now the object of the present improvement is to modify the mechanism above referred to and to provide the same with means of adjustment in such manner that the machine may be readily adapted for combing cotton tufts of various lengths.

For this purpose said pawl or catch is mounted upon an eccentric carried upon the cylinder shaft with capability of angular or radial adjustment thereon, the pawl or catch being furnished with a strap adapted to embrace said eccentric and upon the cylinder shaft is fixed a disc and means are provided for adjustably fixing the eccentric with said disc.

The invention will now be described with reference to the accompanying drawings in which—

Figure 1 is a plan of mechanism constructed according to the present improvement and

Figure 2 is a side elevation thereof.

Referring to the drawings—1 represents the shaft carrying the gear for imparting motion to the front detaching rollers of a combing machine, 2 represents the cylinder shaft 3 represents a plate wheel or disc loosely mounted upon the shaft 1, 4 represents an eccentric mounted upon the shaft 2 and 5 represents an eccentric rod or arm having a strap embracing the eccentric 4 and is connected with the disc or plate wheel 3 as shown whereby an oscillating or to and

fro rotary motion is imparted to said disc or plate wheel.

Carried by the wheel 3 is a tangentially arranged bearing 6 in which is mounted a short shaft 7 upon one end of which is mounted a bevel spur pinion 8 and upon the other end of which is a worm 9 which gears with a worm wheel 10 fixed upon the shaft 1.

The bevel pinion 8 gears with a bevel wheel 11 which is loose upon the shaft and said wheel 11 carries a ratchet wheel 12 which is acted upon by a catch or pawl 13 mounted upon an eccentric 14 loosely mounted upon the cylinder shaft 2.

The eccentric 14 is mounted upon the shaft 2 with capability of angular adjustment and is arranged adjacent a disc or plate wheel 15 fixed upon the shaft 2. In the eccentric 14 is provided a slot 14<sup>a</sup> and the disc or plate wheel 15 which is rotated by the shaft 2 carries a bolt 15<sup>a</sup> which passes through the slot 14<sup>a</sup> of the eccentric 14 and is provided with a nut 15<sup>b</sup> which when tightened up against the face of the eccentric 14 fixes the latter with the disc or plate wheel 15.

In operation the eccentric 4 imparts an oscillating motion to the plate wheel 3 which gives a to and fro motion to the short shaft 7. The bevel wheel 11 is loose on the shaft 1 and the worm 9 is in constant engagement with the worm wheel 10 which is fast on said shaft 1.

In one direction of motion the ratchet wheel 12 and therefore the bevel wheel 11 are free to rotate and the whole gear oscillates without any motion being imparted to the bevel pinion 8 but in the other direction of motion the pawl or catch 13 holds the ratchet wheel and therefore the bevel wheel 11 stationary while the disc or plate wheel carrying the short shaft 7 oscillates so that the bevel wheel 11 rotates the bevel pinion 8 and therefore the worm 9 which drives the worm wheel 10.

By these means the total movement imparted to the front detaching rollers of a combing machine is approximately one revolution forward and one half revolution backward the back detaching rollers being continuously driven by the usual gearing.

The eccentric 14 imparts to the pawl or catch 13 a reciprocating or to and fro motion the time of which may be altered by al-

tering the angular position of the eccentric 14 for which purpose the nut 15<sup>b</sup> is loosened and said eccentric 14 turned by hand into the desired position after which the nut 15<sup>b</sup> is again tightened up fixing the eccentric 5 with the disc or plate wheel 6.

The ratchet wheel 12 receives from the gear above referred to a to and fro motion and the reciprocating motion of the pawl or catch 4 may be so timed that the number of teeth engaged by said pawl may be varied according to the lengths of the tufts. In some cases eccentric 5 may be so adjusted that the pawl 4 will approximately follow the movements of the ratchet wheel 12.

What I claim as my invention and desire to secure by Letters Patent is:—

1. In a combing machine having gear for imparting a partial forward and reverse movement to the detaching rollers a pawl adjustably mounted upon the cylinder shaft, and means for adjusting said pawl in such manner that the movements of the gear and detaching rollers may be varied to accommodate tufts of different lengths substantially as herein set forth.

2. In a combing machine having differen-

tial gear for imparting a partial forward and reverse movement to the detaching rollers, a ratchet wheel carried by said differential gear, a pawl adapted to limit the motion of said ratchet wheel at the time desired, adjustable means upon a suitable mounting for varying the point at which said pawl stops the ratchet wheel so that the rotation of the detaching rollers when backing off may be varied to any desired extent without altering the forward rotation of the rollers substantially as herein set forth.

3. In a combing machine having differential gear for imparting a partial forward and reverse motion to the detaching rollers, a ratchet wheel carried by the differential motion, a disc wheel fixed upon the cylinder shaft, an eccentric loose upon the cylinder shaft, means for fixing said eccentric with said disc wheel, and a pawl having an eccentric strap mounted upon said eccentric and adapted to limit the motion of said ratchet wheel when required substantially as herein set forth.

In testimony whereof I have signed my name to this specification.

JAMES HORRIDGE.