

A. P. AYERS.

4 Sheets—Sheet 1.

Harvester.

No. 104,407.

Patented June 21, 1870.

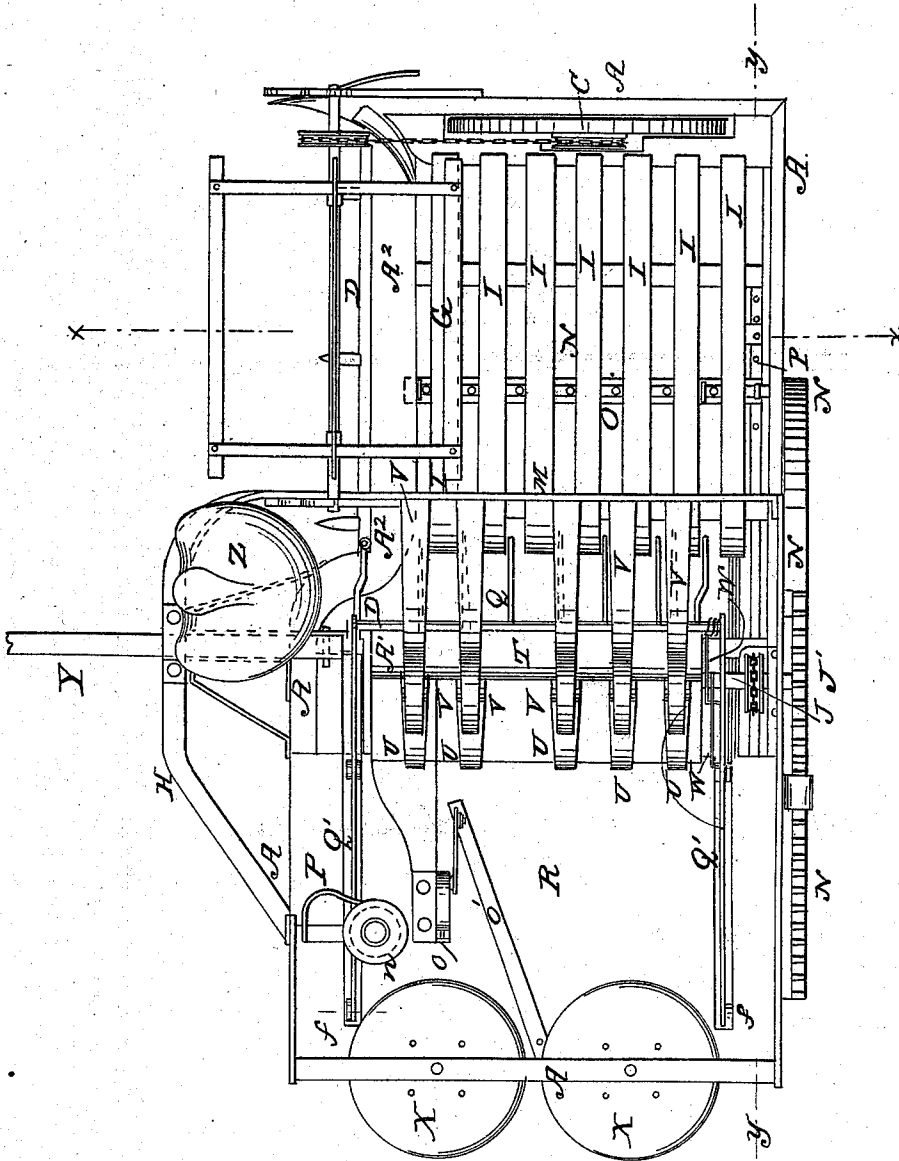

WITNESSES

H. B. Roberts,
Saml. P. Jones

INVENTOR

Almon P. Ayers
Per Attorney
Chas. Sprague

A. P. AYERS.

4 Sheets—Sheet 2.

Harvester.

No. 104,407.

Patented June 21, 1870.

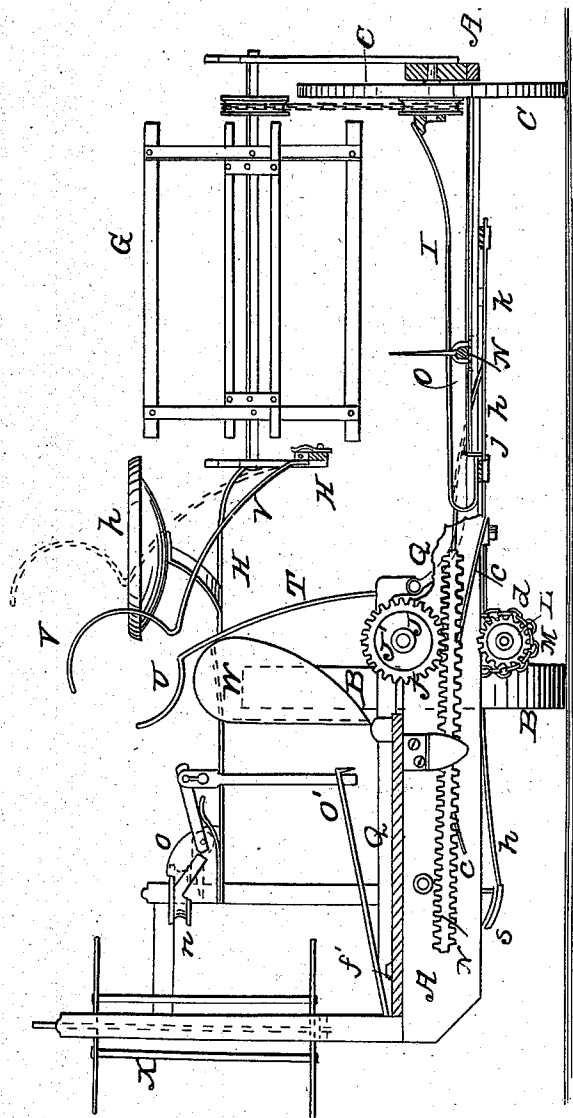

WITNESSES

Chas. E. Roberts
Saml. Jones

INVENTOR

Almon P. Ayers
Per attorney
Chas. S. Sprague

A. P. AYERS.
Harvester.

4 Sheets—Sheet 3.

No. 104,407.

Patented June 21, 1870.

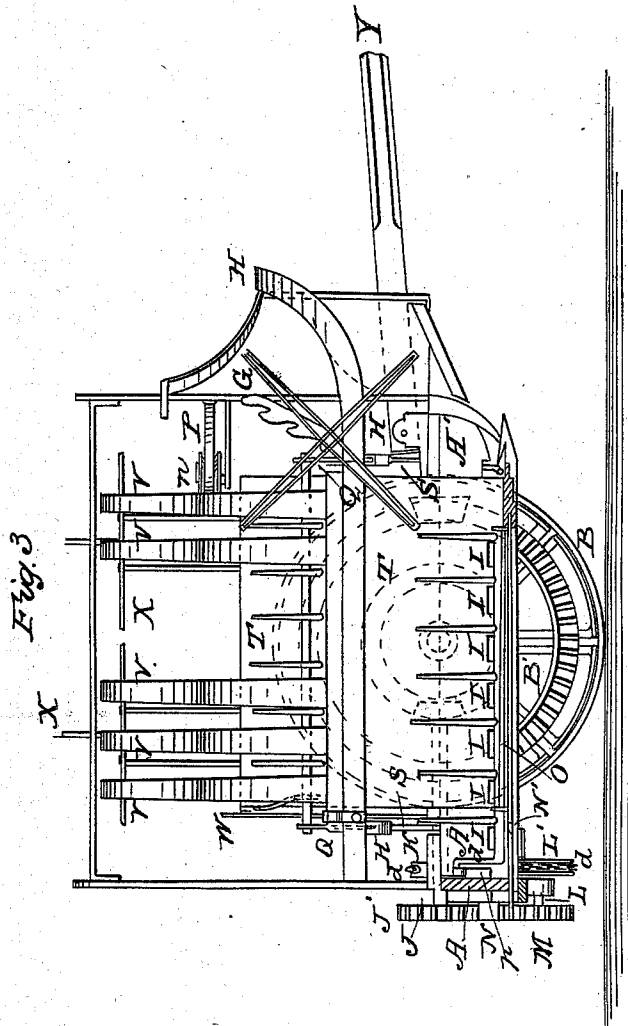

WITNESSES

*H. S. Clark,
Saml. E. Jones*

INVENTOR

*Almon P. Ayers
Per Attorney
Thos. Sprague*

A. P. AYERS.

Harvester.

No. 104,407.

Patented June 21, 1870.

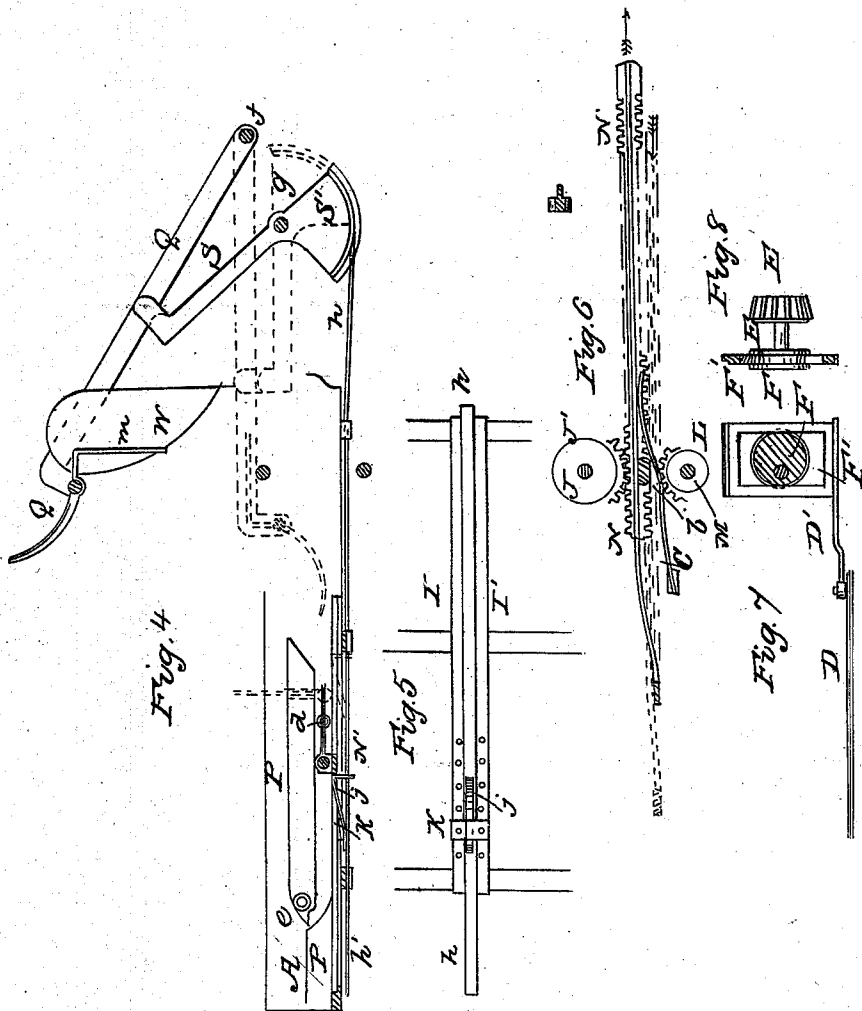

WITNESSES

H. H. Roberts
Saml. Jones

INVENTOR

Almon P. Ayers
Per attorney
Chas. Sprague

UNITED STATES PATENT OFFICE.

ALMON P. AYERS, OF CHICAGO, ILLINOIS.

IMPROVEMENT IN HARVESTERS.

Specification forming part of Letters Patent No. 104,407, dated June 21, 1870.

To all whom it may concern:

Be it known that I, ALMON P. AYERS, of Chicago, in the county of Cook and State of Illinois, have invented a new and useful Improvement in Harvesters; and do declare that the following is a true and accurate description thereof, reference being had to the accompanying drawing, and to the letters of reference marked thereon, and being a part of this specification.

The nature of this invention relates to an improved construction of harvesting-machines.

It consists in the combination of the devices for giving a reciprocating motion to the rake-head; the arrangement of the rake-head upon the platform; the combination of the devices for raising the grain when cut, and for binding it; the arrangement upon the platform of the devices for holding the binding-rope, and for cutting it off as needed; also, in the general arrangement of its various parts, as more fully hereinafter set forth.

Figure 1, Plate 1, is a plan view of my improved harvester. Fig. 2, Plate 2, is a rear elevation of the same. Fig. 3, Plate 3, is a cross-section on the line *x x* in Fig. 1. Fig. 4, Plate 4, is a section on the line *y y* in Fig. 1, looking from the front, to show the operation of the elevator. Fig. 5 is a bottom plan of the loop in which the elevating-strap travels, and which releases its catch, allowing the elevator to drop. Fig. 6 is a detached elevation of the reciprocating rack which operates the rake, looking at it from the front. Fig. 7 is an elevation of the cam which reciprocates the sickle-bar. Fig. 8 is a cross-section of the same.

Like letters indicate like parts in each figure.

In the drawing, A represents the main frame of the carriage, in which is mortised or otherwise secured, at one side of the center, a pair of sills, A¹, extending from front to rear. Between these sills the traction-wheel B is placed, its shaft rotating in suitable bearings in the sills. At the grain side or end of the frame a carrying-wheel, C, is so placed as to support that side of the machine, although the principal weight is supported by the traction-wheel.

A² is the finger-bar, which is attached at either end to the frame A. On the finger-bar the sickle-bar D is placed, being reciprocated by the traction-wheel through its bevel-gear B', which rotates a short shaft, E, through its pinion E'. At the other end of the shaft E is a

cam, F, which reciprocates a cam-frame, F', connected with the sickle-bar by a pitman, D'.

G is a reel, one end of whose shaft is journaled in a standard at the right side of the frame, and the other in a similar standard rising from a metallic frame, H, extending from the front around to the rear of the machine over the inner end of the platform or apron I, which is composed of strips of wood or metal running parallel with the sickle-bar, and secured at their ends to the frame and finger-bar. The reel is rotated in the usual manner by a chain passing over its pulley and one on the shaft of the carrying-wheel C. It is also adjustable vertically, as shown.

J is a shaft, whose rear end overhangs the rear part of the frame of the machine, carrying a spur-wheel, J'. This shaft is rotated by the traction-wheel through bevel-gears on each, as shown in dotted lines in Fig. 3. Within the frame a chain-wheel, K, is secured to the shaft J, which communicates motion to a counter-shaft, L, below, provided with a chain-wheel, L', by means of an endless chain, *a*, passing around both. On the rear end of the counter-shaft a spur-wheel, M, is rigidly secured.

N is a bar, provided with rack-teeth on its upper and under sides at the rear edges thereof, which rack-teeth are alternately caused to engage with the spur-wheels J' and M, and thus reciprocate the rack-bar, the alternating engagement of the racks with the pinions being effected in the following manner: The inner or plain part of the rack-bar is provided with an opening near each end of the racks; a stud, *b*, projects from the rear part of the frame between the gears J' and M; a spring, *c*, secured to the frame under the rack-bar, presses the latter upward as it passes along, the stud underneath keeping the rack on its upper side in gear with the wheel J' until the opening at its grain end is over the stud *b*, when it drops down into gear with the wheel M, which reverses the motion, causing the rack to move toward the standing grain, the stud preventing it from rising until the opening at the other end reaches the stud, when the spring *c* throws it up again into gear with the wheel J', and the motion of the rack-bar is again reversed.

N' is a bar, secured at its rear end to the grain end of the rack-bar extending across and underneath the platform I, reciprocating in

proper slides in the frame and finger-bar. O is a rake-head hinged in the bar N', and provided with rake-teeth adjusted thereto, so that when erect they will travel between the strips I of the platform. The rake-head is provided with a crank-arm, d, which, when the rake is traveling away from the inner end of the platform, passes under the guide P on the inner face of the frame A at the rear of the platform, the rake-teeth lying horizontal until reaching the inclined plane P', up which it ascends until it passes the cam-latch e at the end of the guide P, which drops under it. At this time the travel of the rake is reversed, as hereinbefore described, when it is compelled to move forward on the top of the guide, which causes it to bring the rake-teeth to a vertical position. As it moves toward the inner end of the platform it carries the grain lying there along with it, pushing it off the platform onto an elevator, Q, consisting of a series of hook-shaped rods attached to a shaft journaled in the outer ends of the rods Q', whose inner ends are pivoted at f to the main frame.

g is a rock-shaft journaled in the frame under the binding-platform R. At either end of the shaft is secured a lifting-lever, S, under the elevating rods Q'. The lever, at the rear end of the shaft, is extended beyond the shaft in the form of a sector, S', to the upper corner of which a flexible metallic or other strap, h, is secured. This strap is attached to the end of a bar, h', sliding in ways or guides i on the under side of the platform I. On the upper side of this bar h' is a spring-latch, j, so arranged that when the bar passes with it through a loop, k, the latch is depressed. Now, it will be noticed that as the rake is moving toward the elevator the elevator is lying down, without motion, until the rake throws on it the gavel of grain. As the rake recedes the rake-head comes in contact with the spring-latch on the bar h', and draws it along, and, through the strap and sector, lifts the levers S, which, in turn, raise the elevator-rods Q'. The elevator, with its gavel, is carried up the face of the apron T to an open binding-rack, U, behind which an attendant stands. In its passage up it comes in contact with a series of holders, V, of the form shown in Fig. 2, projecting from the transverse frame H.

In passing up, the gavel is somewhat compressed, and after passing through the contracted part of the binding-rack and holders the latter close under it and hold it while being bound. In the meantime the rake-head has carried the bar h' along until the spring-latch approaches the loop k, passing under which it is depressed, and withdrawn from contact with the rake-head, when the elevator and its attachments fall to a horizontal position of their own gravity, drawing back the strap and bar h'. The rake completes its movement, and in returning with another gavel the rake-head depresses the spring-latch in passing over it, and does not en-

gage with it until it again recedes from the elevator.

The shaft of the elevator is provided with a crank-arm, m, whose wrist-pin, as the elevator rises, passing under a cam, W, causes the shaft to partially rotate, and to discharge the gavel into the binding-rack.

X are spools loosely journaled in the frame at the rear of the binder's platform. On these spools straw rope is wound for binding the gavels with. The rope is led around a pulley, n, through an incased cutting-shears, o, operated by a treadle, o', near which the attendant stands.

Y is the draft-pole, and Z is the driver's seat.

The operation of cutting the grain, raking it in gavels to the elevator, and their delivery to the binding-rack having been already explained, the binding of the gavels is effected in the following manner: The binder, as each gavel is discharged into the binding-rack, draws enough of the hay or straw rope through the jaw of the shear-case to bind it, and cuts it off by depressing the treadle o', which forces the cutter through it.

The free end of the rope is held in place against the pulley by a spring, p. The band is then passed around the gavel held between the rack and holders, and tied, and as the succeeding gavel rises and forces the holders away from the rack, he discharges the bundle at the rear of the machine, when the process is repeated, as described.

What I claim as my invention, and desire to secure by Letters Patent, is—

1. The combination of the shaft J, the gears J' and M, shaft L, chain-wheels K and L', chain a, double-racked bar N, and transverse bar N', for reciprocating the rake-head O, substantially as described and set forth.

2. In combination with the transverse bar N', the rake-head O, provided with crank-arm d, the inclined plane P', guide P, cam-latch e, and open platform I, arranged and operating in relation to each other, substantially as and for the purpose set forth.

3. The combination of the elevator Q, crank m, elevator-rod Q', cam W, apron I, binding-rack U, and gavel-holders V, as and for the purpose set forth.

4. The combination of the elevator-rods Q', the transverse bar N', the lifting-levers S, sector S', strap h, bar h', spring-latch j, loop k, and guides z, arranged and operating in the manner and for the purpose set forth.

5. The arrangement upon the binding-platform of a harvester of the binding-rope, the spools X, the pulley n, the spring p, with the shears o, operated by the treadle o', when the several parts are constructed as described, as and for the purpose set forth.

A. P. AYERS

Witnesses:

H. F. EBERTS,
SAML. E. JONES.