



Europäisches Patentamt  
European Patent Office  
Office européen des brevets



(11) **EP 1 035 998 B1**

(12) **EUROPEAN PATENT SPECIFICATION**

(45) Date of publication and mention  
of the grant of the patent:

**06.03.2002 Bulletin 2002/10**

(21) Application number: **98958826.4**

(22) Date of filing: **02.12.1998**

(51) Int Cl.7: **B63B 25/00**

(86) International application number:  
**PCT/DK98/00527**

(87) International publication number:  
**WO 99/28182 (10.06.1999 Gazette 1999/23)**

(54) **A TRANSPORT SHIP**  
TRANSPORTSCHIFF  
NAVIRE DE TRANSPORT

(84) Designated Contracting States:  
**AT BE CH CY DE DK ES FI FR GB GR IE IT LI LU  
MC NL PT SE**  
Designated Extension States:  
**RO**

(30) Priority: **03.12.1997 DK 139597**  
**22.01.1998 DK 7898**

(43) Date of publication of application:  
**20.09.2000 Bulletin 2000/38**

(73) Proprietor: **IMA international Maritime Advisers**  
**2650 Hvidovre (DK)**

(72) Inventor: **NIELSEN, Jens, M.**  
**DK-2791 Dragor (DK)**

(74) Representative: **Sundien, Thomas et al**  
**Hofman-Bang Zacco A/S, Hans Bekkevolds Allé**  
**7**  
**2900 Hellerup (DK)**

(56) References cited:  
**DE-A1- 4 225 790** **RU-C1- 2 081 023**

**EP 1 035 998 B1**

Note: Within nine months from the publication of the mention of the grant of the European patent, any person may give notice to the European Patent Office of opposition to the European patent granted. Notice of opposition shall be filed in a written reasoned statement. It shall not be deemed to have been filed until the opposition fee has been paid. (Art. 99(1) European Patent Convention).

**Description**

**[0001]** The present invention seeks to solve the problem of providing a transport ship allowing for a high load capacity and flexibility through a unique arrangement of a hold for refrigerated products or a hold for liquid products.

**[0002]** In a first fundamental embodiment the present invention relates to a transport ship having a hull comprising a sheathing and a weather deck and having a front part, a rear part and a central part.

**[0003]** Usually, the rear part of such ships comprises a deck superstructure with the navigating bridge of the ship and the means necessary for the propulsion of the ship, including machinery and fuel tanks, while the front part of the ship comprises the stem and store rooms, if any. The central part of the ship comprises the hold, which is constructed in accordance with the specific type of goods to be transported. The hold may thus be constructed specifically for the transport of one specific type of goods, including e.g. cooled goods, liquid gas, dry cargo, oil or containers. Particularly in former times, the possibilities of utilizing transport ships for carrying combinations of the above-mentioned types of goods were very limited.

**[0004]** To achieve an increased flexibility of goods transport ships to a certain degree, the so-called Ro-Ro ships have been developed in the past twenty years, with a weather deck for the transport of particularly containers and with a plurality of tween decks that may be used for the transport of trailers or e.g. cars which may be loaded using stern ramps.

**[0005]** However, as far as the so-called refrigerator ships are concerned, specifically adapted to transport refrigerated goods, it has not been possible to achieve optimum flexibility and capacity in the past. In particular, the conventional structure of the refrigerator ships and stability deliberations have set a limit to the amounts of additional types of goods that can be carried and to the conditions under which such goods may be carried. Refrigerator ships are typically provided with an internal refrigerated hold over the greater part of the length of the hull, see e.g. European Patent Application No. 0 601 233, said refrigerated hold accommodating a relatively large number of tween decks with a small free height. The reason is that the goods are usually stored on pallets and do not stand stacking in the height. The goods may e.g. be bananas, lemons or vegetables which are to be kept refrigerated during the transport. The goods are typically cargoes which are to be transported over great distances, e.g. from South America to Europe.

**[0006]** In view of the above, it has been attempted to construct the refrigerator ships so as to enable them to carry standard containers which are stacked on the weather deck of the ship. This results in some increased flexibility, as the ship can then be utilized for the transport of refrigerated goods as well as a surface cargo, which may produce increased earnings per voyage. These refrigerator ships, however, are inexpedient, because certain loading situations give rise to stability problems during the voyage of the ship. These problems may occur when the ship, when bound for return, is to sail without refrigerated goods, but with a surface cargo, such as containers. Since the typical surface cargoes are formed by containers of a much greater weight than a corresponding volume of the refrigerated goods, stability deliberations set a limit to how high the containers may be stacked on the weather deck, also when sailing with refrigerated goods.

**[0007]** In "Motor Ship", Jan. 1997, p. 28, a ship as defined in the introductory part of claim 1 and 5 is disclosed. The design of this known ship is based on existing ship designs.

**[0008]** It is an object of the present invention to provide an improved transport ship by means of which, with fewer stability problems, different combinations of goods may be transported, at least one type of which should preferably be capable of being transported in refrigerated form, while allowing greater amounts of the other goods to be transported at the same time. In this connection, different combinations of goods are taken to mean sailing with or without the refrigerated goods, and it must also be possible optionally to transport at least one other type of goods, particularly in the form of standard containers. This provides a high degree of flexibility, so that the owner of the ship can obtain greater earnings per voyage in relation to the known refrigerator ships.

**[0009]** Through the invention it may be possible to achieve approximately the same loading volume for refrigerated goods as in a traditional refrigerator ship of approximately the same length, and the refrigerated hold section is easy to insulate thermally. Moreover, the sunlit surface of the refrigerated hold section will be reduced compared with a traditional refrigerator ship when sailing without surface cargo. In the traditional refrigerator ships, the energy of the sun impinges on the entire weather deck which defines the upper boundary of the refrigerated hold approximately in the entire length of the ship. This will also allow the necessary cooling energy to be reduced. If necessary, the width of the ship may also be slightly greater than that of the traditional refrigerator ship.

**[0010]** This object is achieved according to the invention as defined in the characterising clause of claims 1 and 5.

**[0011]** When the ship is constructed in this manner, it will also be possible to sail without goods in the refrigerated hold, as the rest of the goods may be stowed relatively low against the keel on each side of the refrigerated hold section in the longitudinal direction of the ship. A favourable metacentre height may hereby be maintained, as only the draught of the ship will change. Since, in many conventional refrigerator ships, the rest of the goods must necessarily be carried on the weather deck to avoid damage to the insulated walls, the metacentre height in these ships is very unfavourable when sailing without refrigerated goods in the hold.

**[0012]** According to a particularly preferred embodiment, the upper refrigerated hold deck is arranged at a height above the weather deck of between 50% and 150%, of the moulded depth of the ship measured to the weather deck. The moulded depth is measured from the base line of the ship.

5 **[0013]** It is moreover preferred that the insulated walls extending in the transverse direction directly adjoin the hold section in the front and/or rear part of the ship, and that, optionally, the thermally insulated walls extending in the longitudinal direction also adjoin the sheathing of the hull. This results in optimum utilization of the ship, as the natural walls are utilized for defining the various holds.

10 **[0014]** It is particularly preferred that the upper refrigerated hold deck is adapted to support a cargo, and that the navigating bridge of the ship and the premises of the crew are provided on the upper refrigerated hold deck. All horizontal faces may hereby be utilized for supporting the other type of goods, particularly containers. When the navigating bridge is simultaneously arranged amidships, it is possible to arrange an even very high stack of containers on the weather deck, as the current maritime rules on the mate's line of sight to the horizon are still observed.

15 **[0015]** It is also preferred that the refrigerated hold section is provided with tween decks, and that the distance between the decks is about 2 m - 3 m, preferably about 2.25 m - about 2.5 m. This allows transporting of palleted goods with an optimum utilization of the load volume, as waste of space between the upper side of the pallets and the under side of the tween decks is greatly reduced. Furthermore, like in conventional refrigerator ships, the tween decks may advantageously be constructed as a grating, so that cooling takes place by means of circulating air.

20 **[0016]** When, according to a particularly expedient embodiment, the access to the refrigerated hold section is provided in the thermally insulated walls, preferably in the longitudinal walls, it is possible to load and unload the refrigerated goods and the surface cargo at the same time.

**[0017]** Further, the length of the refrigerated hold section may advantageously constitute between about 20% and 50%, preferably between about 25% and 45%, of the total length of the ship. Hereby, the longitudinal walls of the refrigerated hold section will, to a great extent, be disposed solely within the area of the hull where the sheathing is almost plane, which simplifies the construction of the insulation of the walls.

25 **[0018]** To obtain relatively symmetrical loading conditions to ensure a favourable stability as regards the trim moment of the ship, it is preferred that the thermally insulating walls defining the refrigerated hold section extend symmetrically about the midship section and the middle-line plane of the ship.

30 **[0019]** Finally, it is preferred that access hatches to the hold sections are provided substantially in the entire width of the hold sections. The hold sections in the front and rear parts of the ship may thus be filled and emptied basically in the same manner as in the conventional container ships.

35 **[0020]** In a second fundamental embodiment the present invention relates to a transport ship adapted for simultaneous transport of a cargo consisting of i) a liquid, particularly oil, and ii) a plurality of containers as well as iii) optionally at least one additional type of goods, said transport ship having a hull comprising a sheathing, a bottom, a weather deck and a tank for storing and transporting said liquid, as well as a front part, a rear part and a central part. In this connection, containers are taken to mean standard containers of the type which is generally used for the transport of goods on board container ships.

40 **[0021]** The prior art (see e.g. DE-A-2 462 202) includes a few examples of tankers having an oil tank intended for carrying crude oil and allowing simultaneous transport of an additional type of goods during one and the same voyage. The rear part of these ships usually comprises a deck superstructure with the navigating bridge of the ship and the means necessary for the propulsion of the ship, including machinery and fuel tanks, while the front part of the ship comprises the stem. The central part of the known ship comprises the oil tank whose boundary walls may be formed by the sheathing of the ship. The central part of the ship additionally comprises a plurality of holds intended to accommodate the additional type of goods. Upwardly, the oil tank is defined by the weather deck of the ship, and this is also the case with the said holds.

45 **[0022]** However, it has previously not been possible to achieve optimum flexibility and capacity with these ships. Thus, the ships are inexpedient, because the volume capacity, i.e. the volume of goods that can be carried, for the additional type of goods is merely achieved at the expense of the crude oil volume capacity. When the ship sails without crude oil, it is only possible to transport an amount of the additional type of goods corresponding to the volume capacity of the holds provided for this type of goods. Neither when sailing with the additional cargo and with oil, nor when sailing with the additional cargo alone, is the ship thus utilized optimally.

50 **[0023]** An object of the present invention is to provide an improved transport ship which, with a high load capacity, allows transport of various combinations of goods, at least one type of which is liquid, while allowing simultaneous transport of a considerable number of standard containers and optionally an additional type of goods, such as e.g. general cargo. It must be possible also to transport containers and e.g. general cargo in relatively large amounts, without this causing any considerable reduction in the volume capacity for the liquid, i.e. the liquid volume that can be carried, relatively to a conventional tanker with corresponding dimensions and a corresponding cost of construction. Hereby, when carrying e.g. oil, the owner of the ship can obtain considerably higher earnings per voyage than per voyage with the known tankers.

5 [0024] The above object is achieved according to the invention in that the ship comprises a plurality of hold sections defined by the bottom and the weather deck, said hold sections being adapted to store containers and/or the optional additional type of goods, that the weather deck is adapted to support containers, that the weather deck comprises access hatches giving access to said hold sections, and that the tank for storing the liquid extends from the area at the bottom of the ship upwards to a height above the weather deck. It is preferred to provide the total volume capacity of the tank essentially corresponding to the volume capacity of the tank on a conventional tanker having a hull of corresponding dimensions.

10 [0025] When the ship is constructed in this manner, it will also be possible to sail without a cargo of liquid, as the rest of the goods may be stowed relatively low against the keel on one or both sides of the liquid tank in the longitudinal direction of the ship. It is noted that it is hereby possible to maintain a favourable metacentre height for the normally occurring combinations of cargo, as only the draught of the ship will change considerably by changed load conditions. As only a small part of the hull itself surrounds the liquid tank, the risk of leakage of liquid in case of collision is reduced relatively to conventional tankers.

15 [0026] According to a preferred embodiment of the invention, the tank has a total volume capacity of between about 5,000 and 100,000 m<sup>3</sup>, preferably about 40,000 m<sup>3</sup>, while the hold sections are adapted to accommodate a total of at least 200, preferably at least about 450 standard containers. A ship with such specifications will typically have dimensions which make it possible to sail through the Panama Canal.

20 [0027] Particularly when the front part of the transport ship comprises one of said hold sections, the rear part of the transport ship comprises one of said hold sections, and the central part of the transport ship comprises said tank, it is possible to ensure a symmetrical load impact on the ship under all load conditions.

[0028] It is moreover preferred that the hold sections have transverse walls which are substantially vertical, and which directly adjoin the tank, optionally with intermediate coffer dams, and that the walls of the hold sections extending in the longitudinal direction of the ship are formed by the sheathing of the hull. This provides optimum utilization of the ship, as the natural walls are utilized for defining the various holds.

25 [0029] It is particularly preferred that the tank consists of a plurality of independent compartments which may optionally be cylindrical, box-shaped or spherical, thereby providing the same advantages as in conventional tankers. The cylindrical compartments may be arranged with a vertically or horizontally extending longitudinal axis.

30 [0030] According to a particularly preferred embodiment, the tank extends upwards to a height above the weather deck of between 10% and 200%, preferably between 50% and 150%, of the moulded depth of the ship measured to the weather deck. In this case, the moulded depth is measured from the base line of the ship. In particular, the tank may extend upwards to a height above the weather deck of at least 10 metres, preferably at least 15 metres, and/or be constructed so that its volume above the weather deck constitutes at least 20%, preferably between about 40% and 60%, of the total volume of the tank. This results in a suitable volume capacity ratio for the respective parts of the cargo.

35 [0031] To achieve relatively symmetrical load conditions and thereby ensure a favourable stability as regards the trim moment of the ship, it is preferred that the tank extends symmetrically about the midship section and the middle-line plane.

40 [0032] Finally, it is preferred that access hatches are provided to the hold sections substantially in the entire width of the hold sections. The hold sections may hereby be filled and emptied in the same manner as in conventional container ships.

[0033] As will be realized, the invention as defined in the first and second fundamental embodiments seeks to optimize the load capacity and flexibility of transport ships by using the same general concept of providing an optimal positioning of the hold for refrigerated products or the tank for liquid goods.

45 [0034] The invention will be explained more fully below with reference to the preferred embodiment shown in the drawing. In the drawing:

fig. 1 shows an example of a known type of a refrigerator ship, seen in partial vertical longitudinal section, and

50 fig. 2 shows a preferred embodiment of a refrigerator ship according to the first fundamental embodiment of the invention, seen in partial vertical longitudinal section, and

fig. 3 shows an example of a known type of tanker, seen schematically in a partially vertical longitudinal section, and

55 fig. 4 shows a preferred embodiment of a transport ship according to the second fundamental embodiment of the invention, seen schematically in a partially vertical longitudinal section, and

fig. 5 shows the embodiment of fig. 4 in more detail, seen from the side and provided with a tank comprising vertical, cylindrical compartments.

First fundamental embodiment of the invention

**[0035]** Fig. 1 shows an example of a known refrigerator ship 1 having a hull comprising a sheathing 2, a weather deck 3 and a hold 10. The refrigerator ship 1 has a rear part 5 comprising the machinery necessary for the propulsion of the ship and a deck superstructure comprising premises 6 for the crew and a navigating bridge 7. In addition, the ship 1 comprises a front part 15 with the stem and bulb of the ship, and a central part 9 with a refrigerated hold 10. The refrigerated hold 10 is defined by thermally insulated walls and a thermally insulated bottom, and also the super-jacent weather deck 3 is thermally insulated above the refrigerated hold 10.

**[0036]** The refrigerated hold 10 additionally comprises a plurality of tween decks 11, which are indicated in dashed line, and which may be constructed as a grating, the free height between the tween decks being typically about 2.25 m. This free height is selected in accordance with the height of a standard pallet of refrigerated goods, e.g. bananas, and the tween decks 11 are usually also constructed to allow driving with a fork-lift truck. In the example shown, the ship 1 comprises four tween decks 11, and the height of the ship 1 from the base line to the weather deck is selected so that the desired number of tween decks may be provided. Loading and unloading of the refrigerated hold 10 may take place using elevators or cranes, by means of which the refrigerated goods, indicated in hatched line, may be carried from each tween deck 11 to an access door provided in the side of the ship at a level above the waterline CWL, or optionally to hatches on the weather deck.

**[0037]** The weather deck 3, which forms the closure of the hull upwardly, also serves to support a surface cargo 12, which is indicated in dotted line in the drawing, and which will normally consist of containers stacked on top of each other and lashed to the weather deck 3. The stacking height of the containers 12 will usually be limited partly with a view to the stability of the ship against heeling and partly by international maritime rules, according to which the line of sight 4 from the navigating bridge must reach the surface of the sea at a distance from the stem corresponding to the length of the ship.

**[0038]** The shown conventional refrigerated ship may thus be used for carrying refrigerated goods as well as containers. However, it is clear that the stability of the ship will be affected considerably if the refrigerated hold 10 is empty and only containers on the weather deck 3 are to be carried. This will typically be the case for a return voyage. To compensate for this load situation, ballast tanks, into which sea water is pumped, will normally be incorporated, in many cases up to 30% of the loading capacity of the ship. These tanks, however, take up space at the bottom of the hull that might be used for goods.

**[0039]** The possible stacking height of the containers on the weather deck 3, however, is limited also in the situation where refrigerated goods are transported in the refrigerated hold. The reason is that, in practice, the weight per volume unit of the refrigerated goods, which will typically be bananas, is considerably smaller than the weight per volume unit of the cargo on the weather deck. It is therefore just possible to carry a relatively small number of containers, which must be stacked very low on the weather deck 3.

**[0040]** Seen from an economic point of view, this situation is undesirable of course, as it reduces the earnings of the shipowner unnecessarily.

**[0041]** Fig. 2 shows a vertical longitudinal section through a transport ship 20 according to the first fundamental embodiment of the invention. The shown transport ship 20, like the conventional transport ship, comprises a hull having a sheathing 22, a weather deck 23, 23' and a hold. The hold is divided into three hold sections, and the rear part 25 of the ship comprises the machinery of the ship and a rear hold section 28. The front part 35 of the ship 20 comprises the stem of the ship and a front hold section 28'. Both the front and rear hold sections 28, 28' are defined upwardly by a respective part 23, 23' of the weather deck, which is formed with access hatches giving access to the hold sections for vertical lowering of goods, in particular containers. To permit lowering of the containers, the hatches are preferably provided in the entire width of the hold sections like in conventional container ships, and the hatch covers are constructed to support the surface cargo. Moreover, the front part 23' and the rear part 23 of the weather deck are preferably at the same level above the base line as the weather deck 3 in the conventional refrigerator ship 1.

**[0042]** The ship 20 additionally comprises a central part 29 having a refrigerated hold section 30 indicated by hatched lines, and the extent of the refrigerated hold section 30 in the fore-and-aft direction of the ship preferably constitutes about 25% - 40% of the total length of the ship. The width of the refrigerated hold 30 may preferably correspond to the width of the ship. The refrigerated hold section 30 is intended to transport refrigerated goods, such as bananas or similar food products, or alternatively to transport cooled, liquid gas, and is defined upwardly by a thermally insulated refrigerated hold deck 130. The refrigerated hold section 30 additionally has a thermally insulated bottom which may be arranged close to the ship's bottom, and thermally insulated longitudinal and transverse walls 132, 133, and the front part 23' and the rear part 23 of the weather deck adjoin the transverse walls 132, 133, as shown. The transverse walls 132, 133 moreover preferably form a transverse boundary of the front and rear hold sections 28, 28'. The refrigerated hold deck 130 is preferably adapted to support a deck superstructure with the navigating bridge 27 of the ship 20 and optionally a surface cargo in the form of a minor stack of containers lashed to the refrigerated hold deck 130.

**[0043]** Like the conventional refrigerated holds, the refrigerated hold section 30 is provided with a plurality of fixed

tween decks 31, e.g. in the form of a grating, to which access may be had via an access door (not shown) in the side of the ship and using elevators, and, if necessary, partitions may be provided, dividing the refrigerated hold section 30 into smaller sections in which different temperatures, e.g. above the freezing point and below the freezing point, may be maintained. The distance between the tween decks 31 is determined by the height of a standard pallet and is therefore typically about 2.25 m, like in the conventional refrigerator ships.

**[0044]** In the embodiment shown in fig. 2, the refrigerated hold deck 130 is arranged at a height above the weather deck 23' of about 100% of the moulded depth of the ship measured to the main deck 23' from the base line, which means that the refrigerated hold section 30 comprises a total of eight tween decks, four of which are below the level of the weather deck 23, 23'. It will thus be possible to stack refrigerated goods at a greater height than in the conventional refrigerator ships. When comparing with the conventional refrigerator ship 1 of a corresponding length shown in fig. 1, it will be clear that selection of a suitable height of the refrigerated hold deck 130 will provide the same loading capacity for refrigerated goods.

**[0045]** Fig. 2 moreover shows a situation in which the ship 20 is fully loaded with refrigerated goods (indicated in hatched line) in the refrigerated hold section 30 and with a plurality of containers 32, 32' (indicated in dotted line) stacked on top of each other in the hold sections 28, 28' and on the weather deck 23, 23'. As the weight per volume unit of the refrigerated goods is typically smaller than for the containers, as mentioned before, the possibility of stacking containers near the keel will mean that the total centre of gravity of the cargo is relatively low in relation to a conventional refrigerator ship of a corresponding length and loaded with the same number of containers. It is hereby possible to stack a larger number of containers on top of each other with approximately the same stability conditions as in the conventional refrigerator ship. In the situation of sailing without refrigerated goods, it may moreover be possible to reduce the size of the water ballast in some embodiments.

**[0046]** Table 1 below serves to illustrate some of the advantages of the invention. In the table, the capacity of a ship according to the invention constructed with a length of 150 metres and with a refrigerated hold with a length of about 50 metres, a width corresponding approximately to the width of the ship (about 25 m) and with eight tween decks (fig. 2) is compared with a conventional refrigerator ship with the same length as shown in fig. 1. The building costs for both ships will typically amount to DKK 220 million (1997). For both vessels, the distance between the base line and the weather deck will be about 13.3 m and the width will approximately be the same.

TABLE 1

(First fundamental embodiment of the invention)		
CARGO	THE INVENTION	CONVENTIONAL SHIP
A Bananas	5000 tons	5000 tons
B Bananas	5000 tons	5000 tons
Other cargo	max. 600 containers	max. 150 containers
C Bananas	0	0
Other cargo	max. 600 containers	max. 150 containers

**[0047]** It should be added that the rear weather deck 23 may very well be arranged at a lower level than the front weather deck 23', and then the first-mentioned part of the vessel does not have to be shielded against the waves to the same high extent. In this situation, the position of the refrigerated hold deck 130 relative to the weather deck may then be determined on the basis of the level of the front weather deck 23'.

Second fundamental embodiment of the invention

**[0048]** Fig. 3 shows an example of a conventional tanker 201 having a hull comprising a sheathing 202 and a weather deck 203 which constitutes the upward closure of the hull. The tanker 201 has a rear part 205 comprising the necessary machinery for the propulsion of the ship, fuel tanks and a deck superstructure comprising premises 206 for the crew and a navigating bridge 207. In addition, the ship 201 comprises a front part 215 with the stem and bulb of the ship, and a central part 209 with a hold 210. The hold 210 is formed by a tank which is shown in hatched line, and which comprises a plurality of independent compartments whose walls may be formed by the sheathing 202. The tank is defined upwardly by the weather deck 203 of the ship and downwardly by the bottom 208 of the ship. Ships of this type are typically constructed solely with a view to carrying an amount of liquid, primarily oil, as large as possible, and the ships will have no cargo in the tank when returning to the oil store. The tank is arranged to extend over about 80% of the total length of the tanker in the fore-and-aft direction of the ship.

**[0049]** Because of the current safety rules it is not allowed to carry a surface cargo in the form of e.g. containers above the tank on the weather deck 203 on board conventional tankers, which unduly limits the owner's earnings. If

the safety rules allowed such surface cargoes, the possible stacking height of e.g. containers on the weather deck 203 would be limited in any event when sailing without liquid in the tank, because the metacentre height in this load situation would be very high. Compensation of such stability conditions will generally require mounting of ballast tanks, the result of which is merely that the ship has to sail with a partial, unprofitable load in the form of pumped water. Tankers are thus generally inexpedient, because, if so allowed by the rules, only a relatively limited number of containers can be carried on the weather deck.

**[0050]** Fig. 4 shows a vertical longitudinal section through a transport ship 220 according to the second fundamental embodiment of the invention. The shown transport ship 220, like the conventional tanker, comprises a hull with a sheathing 222, a weather deck 223, 223', a bottom 218 and a hold. The hold is divided into three sections, and the rear part 225 of the ship comprises the machinery of the ship as well as a rear hold section 228. The front part 235 of the ship 220 comprises the stem of the ship and a front hold section 228'. Both the front and rear hold sections 228, 228' are defined upwardly by a respective part 223, 223' of the weather deck, which is formed with access hatches giving access to the hold sections 228, 228' with a view to vertical lowering of goods, in particular containers. To allow lowering of containers or other goods toward the bottom 218, the hatches are preferably arranged in the entire width of the hold sections 228, 228' like in conventional container ships, and the hatch covers are constructed to support a surface cargo in the form of containers 232, 232' placed on the weather deck 223, 223'. The front part 223' and the rear part 223 of the weather deck are moreover preferably at the same level above the base line of the ship as the weather deck 203 in the conventional tanker 201 (fig. 3).

**[0051]** In addition, the transport ship 220 comprises a central part 229 comprising a tank 230, and the extent of the tank 230 in the fore-and-aft direction of the ship preferably constitutes about 25% - 40% of the total length of the ship. The width of the tank 230 may preferably correspond to the width of the ship. The tank 230 is intended to transport liquid goods, such as wine, oil, chemicals or the like, and is defined upwardly by a horizontal tank wall 330, which may optionally comprise the conventional pipe stubs necessary for the filling and emptying. As shown, the front part 223' and the rear part 223 of the weather deck adjoin the tank 230. The transverse walls of the hold sections 228, 228' closest to the tank 230 are preferably substantially vertical and directly adjoin the tank 230, optionally via intermediate coffer dams.

**[0052]** In the embodiment shown in fig. 4, the upper, horizontal tank wall 330 is arranged at a height above the weather deck 223' of about 100% of the moulded depth of the ship measured to the weather deck 223' from the base line. Furthermore, the volume of the part of the tank 230 extending above the weather deck 223' corresponds to about 50% of the total volume of the tank 230. A comparison with the volume capacity of the conventional tanker 201 of a corresponding length shown in fig. 3 will show that selection of a suitable height of the tank wall 330 will generally provide the same volume capacity for liquid in the tank as in the conventional tanker.

**[0053]** Fig. 4 shows a situation where the ship 220 is fully loaded with liquid (indicated in hatched line) in the tank 230 and with a plurality of containers 232, 232' (indicated in dot-hatched line) stacked above each other in the hold sections 228, 228' and on the weather deck 223, 223'. The stacking height of the containers 232, 232' will usually be limited partly owing to the stability of the ship against heeling and partly by international maritime rules, according to which the line of sight 204 from the navigating bridge must reach the surface of the sea at a distance from the stem corresponding to the length of the ship. As the containers may be stowed relatively low against the bottom 218 of the ship, a considerable number of containers can be carried without any danger to the stability of the ship, both without and with a cargo of oil in the tank 230.

**[0054]** Fig. 5 is a lateral more detailed view of the transport ship shown in fig. 4. The figure shows an example of an expedient stacking of the containers 232, 232' and a concrete construction of the tank 230. As will be seen, the tank 230 may consist of a plurality of independent cylindrical compartments, which have a vertically extending longitudinal axis, and which extend from the bottom 218 of the ship to the line of sight 204. The compartments may be arranged at a certain mutual distance and may optionally be adapted for the transport of various types of liquid.

**[0055]** Although fig. 5 shows containers 232, 232' arranged in all hold sections, it is clear that some or all of these hold sections 228, 228' may be filled with another type of goods, e.g. general cargo or particulate goods. Owing to the stability of the ship 220, particularly when sailing without liquid in the tank 230, it will be important to place a cargo, be it general cargo or containers, in the hold sections.

**[0056]** Table 2 below serves to illustrate some of the advantages of the invention. The table compares the capacity of e.g. a ship (see fig. 5) according to the invention constructed with a length of 180 metres and a width of about 30 metres, and with a tank 30 having a volume of 20,000 m<sup>3</sup> and a height from the weather deck 23' to the upper horizontal tank wall 130 of about 30 metres, with a conventional tanker as shown in fig. 3 with the same length/width and the same tank capacity. The cost of construction for both ships will typically amount to DKK 220 million (1997). For both vessels, the distance between the base line and the weather deck will be about 14 m.

TABLE 2

(Second fundamental embodiment of the invention)		
CARGO COMBINATION	THE INVENTION	CONVENTIONAL SHIP
A Oil	16,000 tons	16,000 tons
Containers	0	0
B Oil	16,000 tons	16,000 tons
Containers		
- on deck	about 1000	0
- in hold	about 500	
C Oil	0	0
Containers		
- on deck	about 1000	0
- in hold	about 500	0

[0057] It should be added that the rear weather deck 223 may very well be arranged at a lower level than the front weather deck 223', as the first-mentioned part of the vessel does not have to be shielded against the waves to the same high extent. In this situation, the position of the upper wall 330 or the tank 230 relative to the weather deck may be determined on the basis of the level of the front weather deck 223'.

## Claims

1. A transport ship (20) having a hull comprising a sheathing (22), a weather deck (23, 23') and a hold (28, 28', 30), and having a front part (35), a rear part (25) and a central part (29),

- the front part (35) of the ship comprising a hold section (28') defined by the hull and the weather deck (23'), and access hatches provided in the weather deck (23') to give access to said hold section (28'),
- the rear part (25) of the ship comprising a hold section (28) defined by the hull and the weather deck (23), and access hatches provided in the weather deck (23) to give access to said hold section (28), and
- the central part (29) of the ship comprising a refrigerated hold section (30) defined by an upper thermally insulated refrigerated hold deck (130), a thermally insulated bottom arranged below the weather deck (23, 23') and by thermally insulated walls (132, 133...) extending in the transverse direction and longitudinal direction of the ship,
- said weather deck (23, 23') being adapted to support a cargo, **characterized in**
- a) that the refrigerated hold section (30) is adapted for storing goods above and below the weather deck (23, 23'),
- b) said upper thermally insulated refrigerated hold deck (130) being provided at a height above the weather deck (23, 23') of between 20% and 200% of the moulded depth of the ship (20) measured to the weather deck (23, 23').

2. A transport ship according to claim 1, **characterized in that** tween decks for supporting said goods are arranged at levels above and below said weather deck (23, 23').

3. A transport ship according to any one of the preceding claims, **characterized in**

- **that** the navigating bridge (27) of the ship and the premises (26) of the crew are provided on the upper refrigerated hold deck (130).

4. A transport ship according to any of the preceding claims, **characterized in**

- **that** the upper refrigerated hold deck (130) is provided at a height above the weather deck (23, 23') of between 50% and 150%, of the moulded depth of the ship (20) measured to the weather deck (23, 23').



## EP 1 035 998 B1

5. A transport ship (20) having a hull comprising a sheathing (22), a weather deck (23, 23') and a hold (28, 28', 30), and having a front part (35), a rear part (25) and a central part (29),
- the front part (35) of the ship comprising a hold section (28') defined by the hull and the weather deck (23'), and access hatches provided in the weather deck (23') to give access to said hold section (28'),
  - the rear part (25) of the ship comprising a hold ; section (28) defined by the hull and the weather deck (23), and access hatches provided in the weather deck (23) to give access to said hold section (28), and
  - the central part (29) of the ship comprising a refrigerated hold section (30) defined by an upper thermally insulated refrigerated hold deck (130), a thermally insulated bottom arranged below the weather deck (23, 23'), and by thermally insulated walls (132, 133...) extending in the transverse direction and longitudinal direction of the ship,
  - said weather deck (23, 23') being adapted to support a cargo, **characterized in**
  - i) that the upper thermally insulated refrigerated hold deck (130) is provided at a height above the weather deck (23, 23'),
  - ii) that the refrigerated hold section (30) comprises tween decks for storing palletised goods above and below the level of the weather deck (23, 23'), and
  - iii) that the navigating bridge (27) of the ship and the premises (26) of the crew are provided on the upper refrigerated hold deck (130).
6. A transport ship (20) according to the preceding claim, **characterised in that** the thermally insulated bottom is arranged close to the ships bottom.
7. A transport ship according to any of the preceding claims 5 or 6, **characterized in**
- **that** the upper refrigerated hold deck (130) is provided at a height above the weather deck (23, 23') of between 20% and 200%, preferably between 50% and 150%, of the moulded depth of the ship (20) measured to the weather deck (23, 23').
8. A transport ship according to any of the preceding claims, **characterized in**
- **that** the insulated walls (132, 133) extending in the transverse direction directly adjoin the hold section. (28, 28') in the front and/or rear part (25, 35) of the ship.
9. A transport ship according to any one of the preceding claims, **characterized in**
- **that** the thermally insulated walls extending in the longitudinal direction adjoin the sheathing (22) of the hull.
10. A transport ship according to any one of the preceding claims, **characterized in**
- **that** the upper refrigerated hold deck (130) is adapted to support a cargo.
11. A transport ship according to any one of the preceding claims 2-10, **characterized in**
- **that** the distance between the tween decks is about 2m - 3 m, preferably about 2.25 m - about 2.5 m.
12. A transport ship according to any of the preceding claims 2-11, **characterized in**
- **that** the tween decks (31) are constructed as a grating, and that the cooling takes place by means of circulating air.
13. A transport ship according to any one of the preceding claims, **characterized in**
- **that** the access to the refrigerated hold section (30) is provided in the thermally insulated walls.
14. A transport ship according to any one of the preceding claims, **characterized in**
- **that** the propulsion means of the ship are provided abaft the hold section (28) in the rear part (25).

15. A transport ship according to any one of the preceding claims, **characterized in**

- **that** the length of the refrigerated hold section (30) constitutes between about 20% and 50%, preferably between about 25% and 45%, of the total length of the ship.

16. A transport ship according to any one of the preceding claims, **characterized in**

- **that** the thermally insulated walls (132, 133...) of the refrigerated hold section (30) are arranged symmetrically about the midship section and the middle-line plane.

17. A transport ship according to any one of the preceding claims, **characterized in**

- **that** access hatches to the hold sections (28, 28') are provided substantially in the entire width of the hold sections (28, 28').

18. A transport ship (220) adapted for simultaneous transport of a cargo consisting of i) a liquid, particularly oil, and ii) a plurality of containers (232, 232') as well as iii) optionally at least one additional type of goods, said transport ship having:

- a hull comprising a sheathing (222), a weather deck (223, 223'), a bottom (218) and a tank (230) for storing and transporting said liquid, and
- a front part (235), a rear part (225) and a central part (229),

**characterized in**

- **that** the ship comprises a plurality of hold sections (228, 228') defined by the bottom (218) and the weather deck (223, 223'), said hold sections (228, 228') being adapted to store containers (232, 232') and/or the optional additional type of goods,
- **that** the weather deck (223, 223') is adapted to support containers (232, 232'),
- **that** the weather deck (223, 223') comprises access hatches giving access to said hold sections (228, 228'), and
- **that** the tank (230) for storing the liquid extends from the area at the bottom (218) of the ship upwards to a height above the weather deck (223, 223').

19. A transport ship according to claim 18, **characterized in**

- **that** the total volume capacity of the tank (230) essentially corresponds to the volume capacity of the tank in a conventional tanker (201) having a hull of corresponding dimensions.

20. A transport ship according to claim 18 or 19, **characterized in**

- **that** the tank (230) has a total volume capacity of between about 5,000 and 100,000 m<sup>3</sup>, preferably about 40,000 m<sup>3</sup>, and
- **that** the hold sections (228, 228') are adapted to accommodate a total of at least about 200, preferably at least about 450 standard containers.

21. A transport ship according to any one of the preceding claims 18-20, **characterized in**

- **that** the hold sections (228, 228') have transverse walls which are substantially vertical and which directly adjoin the tank (230), optionally with intermediate coffer dams, and
- **that** the walls of the hold sections (228, 228') extending in the longitudinal direction of the ship are formed by the sheathing (222) of the hull.

22. A transport ship according to any one of the preceding claims 18-21, **characterized in**

- **that** the front part (235) of the transport ship comprises one of said hold sections (228'),
- **that** the rear part (225) of the transport ship comprises one of said hold sections (228), and

- **that** the central part (229) of the transport ship comprises said tank (230).

23. A transport ship according to any one of the preceding claims 18-22, **characterized in**

- **that** the tank (230) is divided into a plurality of independent compartments.

24. A transport ship according to the preceding claim, **characterized in**

- **that** the independent compartments are cylindrical or spherical.

25. A transport ship according to any one of the preceding claims 18-24, **characterised in**

- **that** the tank (230) extends upwards to a height above the weather deck (223, 223') of between 10% and 200%, preferably between 50% and 150%, of the moulded depth of the ship (220) measured to the weather deck (223, 223').

26. A transport ship according to any one of the preceding claims 18-25, **characterized in**

- **that** the tank (230) extends upwards to a height above the weather deck (223, 223') of at least about 10 metres, preferably at least 15 metres.

27. A transport ship according to any one of the preceding claims 18-26, **characterized in**

- **that** the volume of the tank above the weather deck (223, 223') constitutes at least 20%, preferably between about 40% and 60%, of the total volume of the tank.

28. A transport ship according to any one of the preceding claims 18-27, **characterized in**

- **that** access hatches to the hold sections (228, 228') are provided substantially in the entire width of the hold sections (228, 228').

### Patentansprüche

1. Transportschiff (20) mit einem Rumpf, der eine Verschalung (22), ein Wetterdeck (23, 23') und einen Frachtraum (28, 28', 30) aufweist und einen vorderen Abschnitt (35), einen hinteren Abschnitt (25) und einen mittleren Abschnitt (29) hat, wobei

der vordere Abschnitt (35) des Schiffes einen Frachtraumabschnitt (28'), der durch den Rumpf und das Wetterdeck (23') definiert ist, und Zugangsluken aufweist, die in dem Wetterdeck (23') vorgesehen sind, um einen Zugang zu dem Frachtraumabschnitt (28') zu gestatten,

der hintere Abschnitt (25) des Schiffes einen Frachtraumabschnitt (28), der durch den Rumpf und das Wetterdeck (23) definiert ist, und Zugangsluken aufweist, die in dem Wetterdeck (23) vorgesehen sind, um einen Zugang zu dem Frachtraumabschnitt (28) zu gestatten, und

- der mittlere Abschnitt (29) des Schiffes einen Kühlfrachtraumabschnitt (30) aufweist, der durch ein oberes thermisch isoliertes Kühlfrachtraumdeck (130), einen thermisch isolierten Boden, der unterhalb des Wetterdecks (23, 23') angeordnet ist, und durch thermisch isolierte oder thermisch isolierende Wände (132, 133, ...) definiert ist, die sich in der Querrichtung und in der Längsrichtung des Schiffes erstrecken, wobei

das Wetterdeck (23, 23') an ein Stützen einer Ladung angepasst ist,

**dadurch gekennzeichnet, dass**

- a) der Kühlfrachtraumabschnitt (30) an ein Lagern von Gütern oberhalb und unterhalb des Wetterdecks (23, 23') angepasst ist,
- b) das obere thermisch isolierte Kühlfrachtraumdeck (130) in einer Höhe oberhalb des Wetterdecks (23, 23')

von zwischen 20 % und 200 % der Seitenhöhe des Schiffes (20) gemessen bis zu dem Wetterdeck (23, 23') vorgesehen ist.

- 5 2. Transportschiff gemäß Anspruch 1,  
**dadurch gekennzeichnet, dass**

Zwischendecks zum Stützen der Güter bei Höhen oberhalb und unterhalb des Wetterdecks (23, 23') angeordnet sind.

- 10 3. Transportschiff gemäß einem der vorherigen Ansprüche,  
**dadurch gekennzeichnet, dass**

die Navigationsbrücke (27) des Schiffes und die Mannschaftsräume (26) auf dem oberen Kühlfrachtraumdeck (130) vorgesehen sind.

- 15 4. Transportschiff gemäß einem der vorherigen Ansprüche,  
**dadurch gekennzeichnet, dass**

das obere Kühlfrachtraumdeck (130) in einer Höhe oberhalb des Wetterdecks (23, 23') von zwischen 50 % und 150 % der Seitenhöhe des Schiffes (20) gemessen bis zu dem Wetterdeck (23, 23') vorgesehen ist.

- 20 5. Transportschiff (20) mit einem Rumpf, der eine Verschalung (22), ein Wetterdeck (23, 23') und einen Frachtraum (28, 28', 30) aufweist und einen vorderen Abschnitt (35), einen hinteren Abschnitt (25) und einen mittleren Abschnitt (29) hat, wobei

25 der vordere Abschnitt (35) des Schiffes einen Frachtraumabschnitt (28'), der durch den Rumpf und das Wetterdeck (23') definiert ist, und Zugangsluken aufweist, die in dem Wetterdeck (23') vorgesehen sind, um einen Zugang zu dem Frachtraumabschnitt (28') zu gestatten,

der hintere Abschnitt (25) des Schiffes einen Frachtraumabschnitt (28), der durch den Rumpf und das Wetterdeck (23) definiert ist, und Zugangsluken aufweist, die in dem Wetterdeck (23) vorgesehen sind, um einen Zugang zu dem Frachtraumabschnitt (28) zu gestatten, und

30 - der mittlere Abschnitt (29) des Schiffes einen Kühlfrachtraumabschnitt (30) aufweist, der durch ein oberes thermisch isoliertes Kühlfrachtraumdeck (130), einen thermisch isolierten Boden, der unterhalb des Wetterdecks (23, 23') angeordnet ist, und durch thermisch isolierte oder thermisch isolierende Wände (132, 133, ...) definiert ist, die sich in der Querrichtung und in der Längsrichtung des Schiffes erstrecken, wobei

35 das Wetterdeck (23, 23') an ein Stützen einer Ladung angepasst ist,

**dadurch gekennzeichnet, dass**

40 i) das obere thermisch isolierte Kühlfrachtraumdeck (130) bei einer Höhe oberhalb des Wetterdecks (23, 23') vorgesehen ist,

ii) der Kühlfrachtraumabschnitt (30) Zwischendecks zum Lagern von auf Paletten gelagerten Gütern oberhalb und unterhalb der Höhe des Wetterdecks (23, 23') aufweist, und

45 iii) die Navigationsbrücke (27) des Schiffes und die Mannschaftsräume (26) auf dem oberen Kühlfrachtraumdeck (130) vorgesehen sind.

6. Transportschiff (20) gemäß dem vorhergehenden Anspruch,  
**dadurch gekennzeichnet, dass**

der thermisch isolierte Boden in der Nähe des Schiffbodens angeordnet ist.

- 50 7. Transportschiff gemäß einem der vorherigen Ansprüche 5 oder 6,  
**dadurch gekennzeichnet, dass**

das obere Kühlfrachtraumdeck (130) in einer Höhe oberhalb des Wetterdecks (23, 23') von zwischen 20 % und 200 % und vorzugsweise zwischen 50 % und 150 % der Seitenhöhe des Schiffes (20) gemessen bis zu dem Wetterdeck (23, 23') vorgesehen ist.

- 55 8. Transportschiff gemäß einem der vorherigen Ansprüche,  
**dadurch gekennzeichnet, dass**

die isolierten Wände (132, 133), die sich in der Querrichtung erstrecken, direkt an den Frachtraumabschnitt

(28, 28') in dem vorderem und / oder hinterem Abschnitt (25, 35) des Schiffes angrenzen.

9. Transportschiff gemäß einem der vorherigen Ansprüche,  
**dadurch gekennzeichnet, dass**  
5 die thermisch isolierten Wände, die sich in der Längsrichtung erstrecken, an die Verschalung (22) des Rumpfes angrenzen.
10. Transportschiff gemäß einem der vorherigen Ansprüche,  
**dadurch gekennzeichnet, dass**  
10 das obere Kühlfrachtraumdeck (130) an ein Stützen einer Ladung angepasst ist.
11. Transportschiff gemäß einem der vorherigen Ansprüche 2 - 10,  
**dadurch gekennzeichnet, dass**  
15 der Abstand zwischen den Zwischendecks ungefähr 2 m bis 3 m und vorzugsweise ungefähr 2,25 m bis ungefähr 2,5 m beträgt.
12. Transportschiff gemäß einem der vorherigen Ansprüche 2 - 11,  
**dadurch gekennzeichnet, dass**  
20 die Zwischendecks (31) als ein Grating aufgebaut sind und das Kühlen mittels umlaufender Luft stattfindet.
13. Transportschiff gemäß einem der vorherigen Ansprüche,  
**dadurch gekennzeichnet, dass**  
der Zugang zu dem Kühlfrachtraumabschnitt (30) in den thermisch isolierten Wänden vorgesehen ist.
- 25 14. Transportschiff gemäß einem der vorherigen Ansprüche,  
**dadurch gekennzeichnet, dass**  
die Antriebseinrichtung des Schiffes achtern von dem Frachtraumabschnitt (28) in dem hinteren Abschnitt (25) vorgesehen sind.
- 30 15. Transportschiff gemäß einem der vorherigen Ansprüche,  
**dadurch gekennzeichnet, dass**  
die Länge des Kühlfrachtraumabschnittes (30) zwischen ungefähr 20 % und 50 % und vorzugsweise zwischen ungefähr 25 % und 45 % der Gesamtlänge des Schiffes beträgt.
- 35 16. Transportschiff gemäß einem der vorherigen Ansprüche,  
**dadurch gekennzeichnet, dass**  
die thermisch isolierten Wände (132, 133, ...) zu des Kühlfrachtraumabschnittes (30) symmetrisch um den Mittelschiffabschnitt und die Mittellinieebene angeordnet sind.
- 40 17. Transportschiff gemäß einem der vorherigen Ansprüche,  
**dadurch gekennzeichnet, dass**  
die Zugangsluken zu den Frachtraumabschnitten (28, 28') im wesentlichen in der gesamten Breite der Frachtraumabschnitte (28, 28') vorgesehen sind.
- 45 18. Transportschiff (220), das an einen gleichzeitigen Transport einer Ladung angepasst ist, die aus i) einer Flüssigkeit insbesondere Öl und ii) einer Vielzahl an Containern (232, 232') und auch iii) wahlweise zumindest einer zusätzlichen Art an Gütern besteht, wobei das Transportschiff folgendes aufweist:
- 50 einen Rumpf mit einer Verschalung (222), einem Wetterdeck (223, 223'), einem Boden (218) und einem Tank (230) für ein Speichern und Transportieren der Flüssigkeit und einen vorderen Abschnitt (235), einen hinteren Abschnitt (225) und einen mittleren Abschnitt (229),  
**dadurch gekennzeichnet, dass**  
55 das Schiff eine Vielzahl an Frachtraumabschnitten (228, 228') aufweist, die durch den Boden (218) und das Wetterdeck (223, 223') definiert sind, wobei die Frachtraumabschnitte (228, 228') an ein Lagern von Containern (232, 232') und / oder der wahlweisen anderen Art an Gütern angepasst sind, das Wetterdeck (223, 223') an ein Stützen der Container (232, 232') angepasst ist,

das Wetterdeck (223, 223') Zugangsluken aufweist, die einen Zugang zu den Frachtraumabschnitten (228, 228') gestatten, und  
der Tank (230) für ein Speichern der Flüssigkeit sich von der Fläche an dem Boden (218) des Schiffes in der nach obenweisenden Richtung bis zu einer Höhe oberhalb des Wetterdecks (223, 223') erstreckt.

- 5
19. Transportschiff gemäß Anspruch 18,  
**dadurch gekennzeichnet, dass**  
die Gesamtvolumenkapazität des Tanks (230) im wesentlichen der Volumenkapazität des Tanks bei einem herkömmlichen Tanker (201) mit einem Rumpf mit entsprechenden Abmessungen entspricht.
- 10
20. Transportschiff gemäß Anspruch 18 oder 19,  
**dadurch gekennzeichnet, dass**  
der Tank (230) eine Gesamtvolumenkapazität von zwischen ungefähr 5.000 und 100.000 m<sup>3</sup> und vorzugsweise ungefähr 40.000 m<sup>3</sup> aufweist und  
die Frachtraumabschnitte (228, 228') an ein Unterbringen von insgesamt zumindest ungefähr 200 und vorzugsweise zumindest ungefähr 450 Normcontainern angepasst sind.
- 15
21. Transportschiff gemäß einem der vorherigen Ansprüche 18 bis 20,  
**dadurch gekennzeichnet, dass**  
die Frachtraumabschnitte (228, 228') quer verlaufende Wände haben, die im wesentlichen vertikal sind und die direkt an den Tank (230) wahlweise mit Zwischenkofferdämmen angrenzen, und  
die Wände der Frachtraumabschnitte (228, 228') die sich in der Längsrichtung des Schiffes erstrecken, durch die Verschalung (222) des Rumpfes ausgebildet sind.
- 20
22. Transportschiff gemäß einem der vorherigen Ansprüche 18 bis 21,  
**dadurch gekennzeichnet, dass**  
der vordere Abschnitt (235) des Transportschiffes einen der Frachtraumabschnitte (228') aufweist,  
der hintere Abschnitt (225) des Transportschiffes einen der Frachtraumabschnitte (228) aufweist und  
der mittlere Abschnitt (229) des Transportschiffes den Tank (230) aufweist.
- 25
23. Transportschiff gemäß einem der vorherigen Ansprüche 18 bis 22,  
**dadurch gekennzeichnet, dass**  
der Tank (230) in eine Vielzahl an unabhängigen Räumen unterteilt ist.
- 30
24. Transportschiff gemäß dem vorherigen Anspruch,  
**dadurch gekennzeichnet, dass**  
die unabhängigen Räume zylindrisch oder kugelartig sind.
- 35
25. Transportschiff gemäß einem der vorherigen Ansprüche 18 bis 24,  
**dadurch gekennzeichnet, dass**  
der Tank (230) sich in der nach obenweisenden Richtung bis zu einer Höhe oberhalb des Wetterdecks (223, 223') von zwischen 10 % und 200 % und vorzugsweise zwischen 50 % und 150 % der Seitenhöhe des Schiffes (220) gemessen bis zu dem Wetterdeck (223, 223') erstreckt.
- 40
26. Transportschiff gemäß einem der vorherigen Ansprüche 18 bis 25,  
**dadurch gekennzeichnet, dass**  
der Tank (230) sich in der nach obenweisenden Richtung bis zu einer Höhe oberhalb des Wetterdecks (223, 223') von zumindest ungefähr 10 m und vorzugsweise zumindest 15 m erstreckt.
- 45
27. Transportschiff gemäß einem der vorherigen Ansprüche 18 bis 26,  
**dadurch gekennzeichnet, dass**  
das Volumen des Tanks oberhalb des Wetterdecks (223, 223') zumindest 20 % und vorzugsweise zwischen ungefähr 40 % und 60 % des Gesamtvolumens des Tanks beträgt.
- 50
28. Transportschiff gemäß einem der vorherigen Ansprüche 18 bis 27,
- 55

**dadurch gekennzeichnet, dass**

Zugangsluken zu den Frachtraumabschnitten (228, 228') im wesentlichen in der gesamten Breite der Frachtraumabschnitte (228, 228') vorgesehen sind.

5

**Revendications**

1. Bateau de transport (20) ayant une coque comportant un revêtement (22), un pont supérieur (23, 23') et une cale (28, 28', 30) et ayant une partie avant (35), une partie arrière (25) et une partie centrale (29),

10

- la partie avant (35) du bateau comportant une section de cale (28') définie par la coque et le pont supérieur (23'), et des écoutilles d'accès prévues dans le pont supérieur (23') afin de permettre l'accès à ladite section de cale (28'),
- la partie arrière (25) du bateau comportant une section de cale (28) définie par la coque et le pont supérieur (23), et des écoutilles d'accès prévues dans le pont supérieur (23) afin de permettre l'accès à ladite section de cale (28), et
- la partie centrale (29) du bateau comportant une section de cale réfrigérée (30) définie par un pont de cale réfrigérée thermiquement isolé supérieur (130), un fond isolé thermiquement disposé sous le pont supérieur (23, 23') et par des parois isolées thermiquement (132, 133...) s'étendant dans la direction transversale et la direction longitudinale du bateau,
- ledit pont supérieur (23, 23') étant prévu pour supporter un chargement,

15

20

**caractérisé en ce que**

25

- a) la section de cale réfrigérée (30) est prévue pour stocker des marchandises au-dessus et en dessous du pont supérieur (23, 23'),
- b) ledit pont de cale réfrigérée thermiquement isolé supérieur (130) étant prévu à une hauteur au-dessus du pont supérieur (23, 23') entre 20 % et 200 % du creux sur quille du bateau (20) mesuré jusqu'au pont supérieur (23, 23').

30

2. Bateau de transport selon la revendication 1, **caractérisé** en de que des entreponts destinés à supporter lesdites marchandises sont disposés à des niveaux au-dessus et en dessous dudit pont supérieur (23, 23').

35

3. Bateau de transport selon l'une quelconque des revendications précédentes, **caractérisé en ce que** la passerelle de navigation (27) du bateau et les quartiers (26) de l'équipage sont prévus sur le pont de cale réfrigérée supérieur (130).

40

4. Bateau de transport selon l'une quelconque des revendications précédentes, **caractérisé en ce que** le pont de cale réfrigérée supérieur (130) est prévu à une hauteur au-dessus du pont supérieur (23, 23') entre 50 % et 150 % du creux sur quille du bateau (20) mesuré jusqu'au pont supérieur (23, 23').

45

5. Bateau de transport (20) ayant une coque comportant un revêtement (22), un pont supérieur (23, 23') et une cale (28, 28', 30) et ayant une partie avant (35), une partie arrière (25) et une partie centrale (29),

50

- la partie avant (35) du bateau comportant une section de cale (28') définie par la coque et le pont supérieur (23'), et des écoutilles d'accès prévues dans le pont supérieur (23') afin de permettre l'accès à ladite section de cale (28'),
- la partie arrière (25) du bateau comportant une section de cale (28) définie par la coque et le pont supérieur (23), et des écoutilles d'accès prévues dans le pont supérieur (23) afin de permettre l'accès à ladite section de cale (28), et
- la partie centrale (29) du bateau comportant une section de cale réfrigérée (30) définie par un pont de cale réfrigérée thermiquement isolé supérieur (130), un fond isolé thermiquement disposé sous le pont supérieur (23, 23') et par des parois isolées thermiquement (132, 133...) s'étendant dans la direction transversale et la direction longitudinale du bateau,

55

- ledit pont supérieur (23, 23') étant prévu pour supporter un chargement,

**caractérisé en ce que**

- i) le pont de cale réfrigérée thermiquement isolé supérieur (130) est prévu à une hauteur au-dessus du

## EP 1 035 998 B1

- 5 pont supérieur (23, 23'),
- ii) la section de cale réfrigérée (30) comprend des entreponts pour stocker des marchandises sur palette au-dessus et en dessous du niveau du pont supérieur (23, 23'), et
  - iii) la passerelle de navigation (27) du bateau et les quartiers (26) de l'équipage sont prévus sur le pont de cale réfrigérée supérieur (130).
- 10 6. Bateau de transport (20) selon la revendication précédente, **caractérisé en ce que** le fond thermiquement isolé est disposé près du fond du bateau.
- 15 7. Bateau de transport selon l'une quelconque des revendications 5 ou 6, **caractérisé en ce que** le pont de cale réfrigérée supérieur (130) est prévu à une hauteur au-dessus du pont supérieur (23, 23') entre 20 % et 200 %, de préférence entre 50 % et 150 %, du creux sur quille du bateau (20) mesuré jusqu'au pont supérieur (23, 23').
- 20 8. Bateau de transport selon l'une quelconque des revendications précédentes, **caractérisé en ce que** les parois isolées (132, 133...) s'étendant dans la direction transversale rejoignent directement la section de cale (28, 28') dans la partie avant et/ou arrière (25, 35) du bateau.
- 25 9. Bateau de transport selon l'une quelconque des revendications précédentes, **caractérisé en ce que** les parois thermiquement isolées s'étendant dans la direction longitudinale rejoignent le revêtement (22) de la coque.
- 30 10. Bateau de transport selon l'une quelconque des revendications précédentes, **caractérisé en ce que** le pont de cale réfrigérée supérieur (130) est prévu pour supporter un chargement.
- 35 11. Bateau de transport selon l'une quelconque des revendications précédentes 2 à 10, **caractérisé en ce que** la distance entre les entreponts est d'environ 2 m à 3 m, de préférence environ 2,25 m à environ 2,5 m.
- 40 12. Bateau de transport selon l'une quelconque des revendications 2 à 11 précédentes, **caractérisé en ce que** les entreponts (31) sont construits sous forme d'un caillebotis, et **en ce que** le refroidissement se fait au moyen d'une circulation d'air.
- 45 13. Bateau de transport selon l'une quelconque des revendications précédentes, **caractérisé en ce que** l'accès à la section de cale réfrigérée (30) est prévu dans les parois thermiquement isolées.
- 50 14. Bateau de transport selon l'une quelconque des revendications précédentes, **caractérisé en ce que** les moyens de propulsion du bateau sont prévus sur l'arrière de la section de cale (28) dans la partie arrière (25).
- 55 15. Bateau de transport selon l'une quelconque des revendications précédentes, **caractérisé en ce que** la longueur de la section de cale réfrigérée (30) constitue entre environ 20 % et 50 %, de préférence entre environ 25 % et 45 %, de la longueur totale du bateau.
16. Bateau de transport selon l'une quelconque des revendications précédentes, **caractérisé en ce que** les parois isolées thermiquement (132, 133 ...) de la section de cale réfrigérée (30) sont disposées de manière symétrique autour de la section médiane et du plan médian du bateau.
17. Bateau de transport selon l'une quelconque des revendications précédentes, **caractérisé en ce que** des écoutilles d'accès vers les sections de cale (28, 28') sont prévues sensiblement sur toute la largeur des sections de cale (28, 28').
18. Bateau de transport (220) prévu pour le transport simultané d'un chargement se composant de i) un liquide, en particulier du pétrole, et ii) plusieurs conteneurs (232, 232') ainsi que iii) éventuellement au moins un genre supplémentaire de marchandises, ledit bateau de transport ayant :
- une coque comportant un revêtement (222), un pont supérieur (223, 223'), un fond (218) et un réservoir (230) pour le stockage et le transport dudit liquide, et
  - une partie avant (235), une partie arrière (225) et une partie centrale (229),

**caractérisé en ce que**



## EP 1 035 998 B1

- le bateau comporte plusieurs sections de cale (228, 228') définies par le fond (218) et le pont supérieur (223, 223'), lesdites sections de cale (228, 228') étant prévues pour stocker des conteneurs (232, 232') et/ou le genre supplémentaire optionnel de marchandises,
  - le pont supérieur (223, 223') est prévu pour supporter des conteneurs (232, 232'),
  - le pont supérieur (223, 223') comprend des écoutilles d'accès donnant accès aux dites sections de cale (228, 228'), et
  - le réservoir (230) pour le stockage du liquide s'étend depuis la zone au niveau du fond (218) du bateau vers le haut, jusqu'à une hauteur au-dessus du pont supérieur (223, 223').
- 10 **19.** Bateau de transport selon la revendication 18, **caractérisé en ce que** la capacité en volume total du réservoir (230) correspond essentiellement à la capacité en volume du réservoir dans un pétrolier (201) conventionnel ayant une coque de dimensions correspondantes.
- 15 **20.** Bateau de transport selon la revendication 18 ou 19, **caractérisé en ce que**
- le réservoir (230) a une capacité volumique totale d'environ 5000 à 100000 m<sup>3</sup>, de préférence d'environ 40000 m<sup>3</sup>, et
  - les sections de cale (228, 228') sont prévues pour recevoir un total d'au moins environ 200, de préférence d'au moins environ 450 conteneurs standards.
- 20 **21.** Bateau de transport selon l'une quelconque des revendications 18 à 20 précédentes, **caractérisé en ce que**
- les sections de cale (228, 228') ont des parois transversales qui sont sensiblement verticales et qui rejoignent directement le réservoir (230), éventuellement avec des caissons hydrauliques intermédiaires, et
  - les parois des sections de cale (228, 228') s'étendant dans la direction longitudinale du bateau sont formées par le revêtement (222) de la coque.
- 25 **22.** Bateau de transport selon l'une quelconque des revendications 18 à 21 précédentes, **caractérisé en ce que**
- la partie avant (235) du bateau de transport comprend une desdites sections de cale (228'),
  - la partie arrière (225) du bateau de transport comporte une desdites sections de cale (228), et
  - la partie centrale (229) du bateau de transport comporte ledit réservoir (230).
- 30 **23.** Bateau de transport selon l'une quelconque des revendications 18 à 22 précédentes, **caractérisé en ce que** le réservoir (230) est divisé en plusieurs compartiments indépendants.
- 35 **24.** Bateau de transport selon la revendication précédente, **caractérisé en ce que** les compartiments indépendants sont cylindriques ou sphériques.
- 40 **25.** Bateau de transport selon l'une quelconque des revendications 18 à 24 précédentes, **caractérisé en ce que** le réservoir (230) s'étend vers le haut jusqu'à une hauteur au-dessus du pont supérieur (223, 223') entre 10 % et 200 %, de préférence entre 50 % et 150 %, du creux sur quille du bateau (220) mesuré jusqu'au pont supérieur (223, 223').
- 45 **26.** Bateau de transport selon l'une quelconque des revendications 18 à 25 précédentes, **caractérisé en ce que** le réservoir (230) s'étend vers le haut jusqu'à une hauteur au-dessus du pont supérieur (223, 223') d'au moins environ 10 mètres, de préférence au moins 15 mètres.
- 50 **27.** Bateau de transport selon l'une quelconque des revendications 18 à 26 précédentes, **caractérisé en ce que** le volume du réservoir au-dessus du pont supérieur (223, 223') constitue au moins 20 %, de préférence entre environ 40 % et 60 %, du volume total du réservoir.
- 55 **28.** Bateau de transport selon l'une quelconque des revendications 18 à 27 précédentes, **caractérisé en ce que** des écoutilles d'accès vers les sections de cale (228, 228') sont prévues sensiblement sur toute la largeur des sections de cale (228, 228').

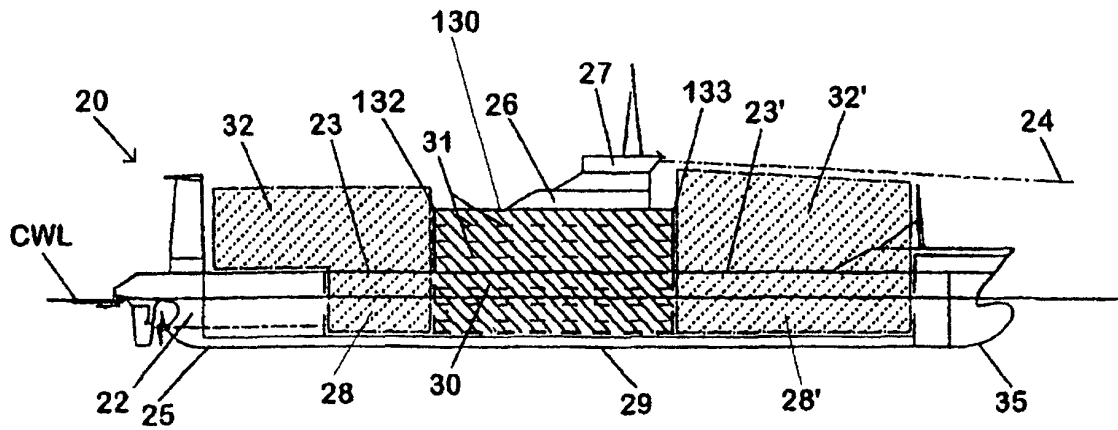

FIG. 2

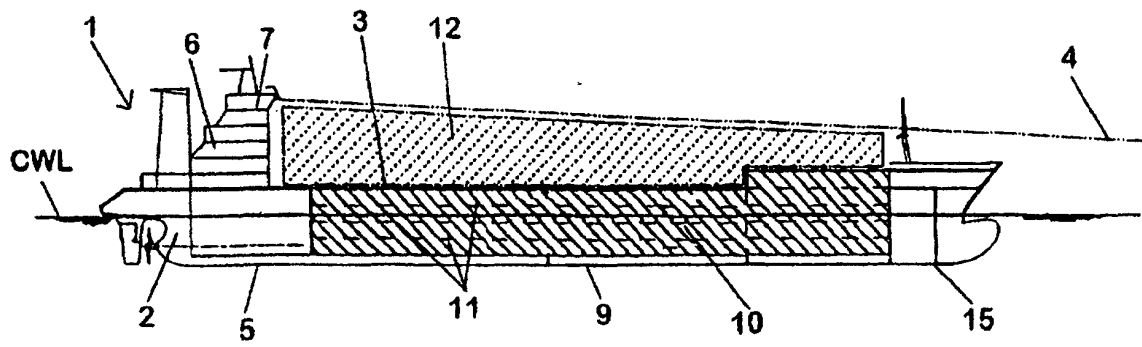

FIG. 1

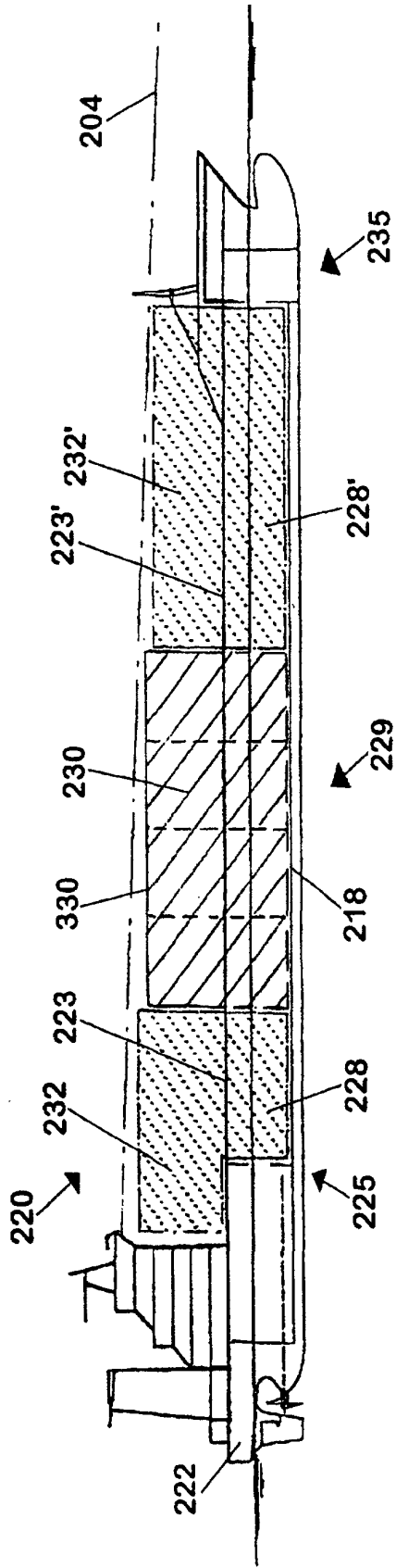

FIG. 4

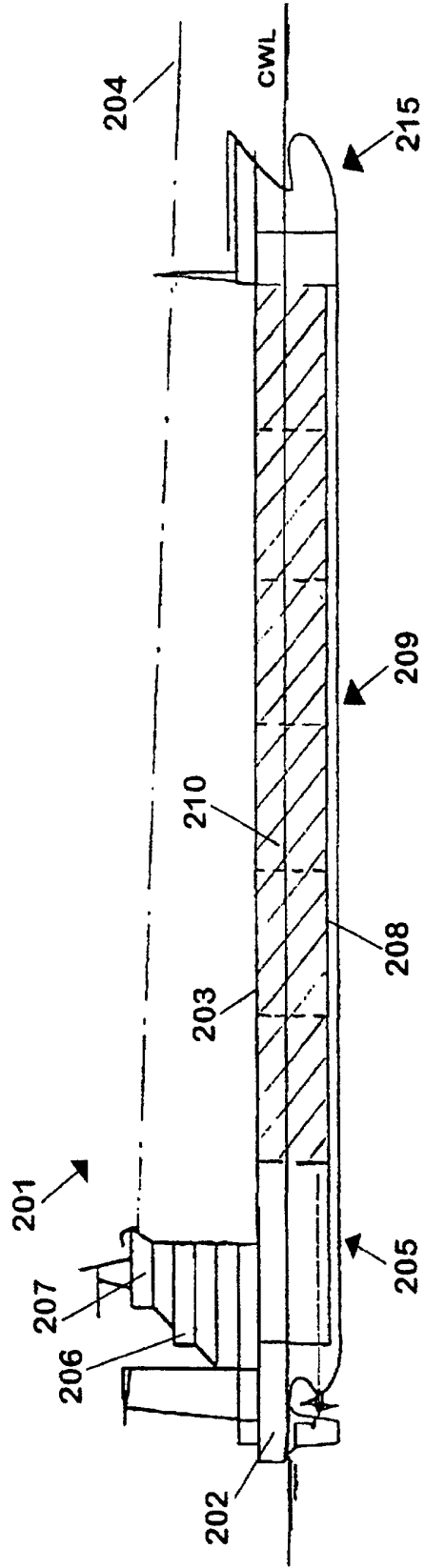

FIG. 3

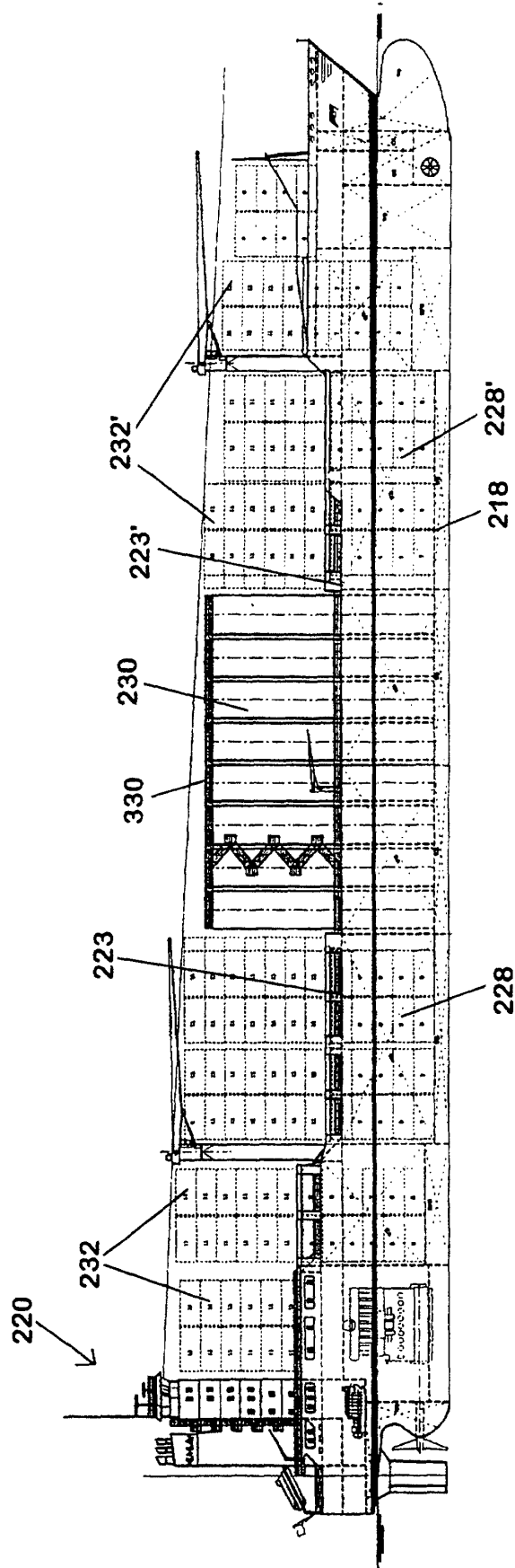

FIG. 5