

J. A. BOWDEN.
FILTER.

No. 559,096.

Patented Apr. 28, 1896.

Fig-1.

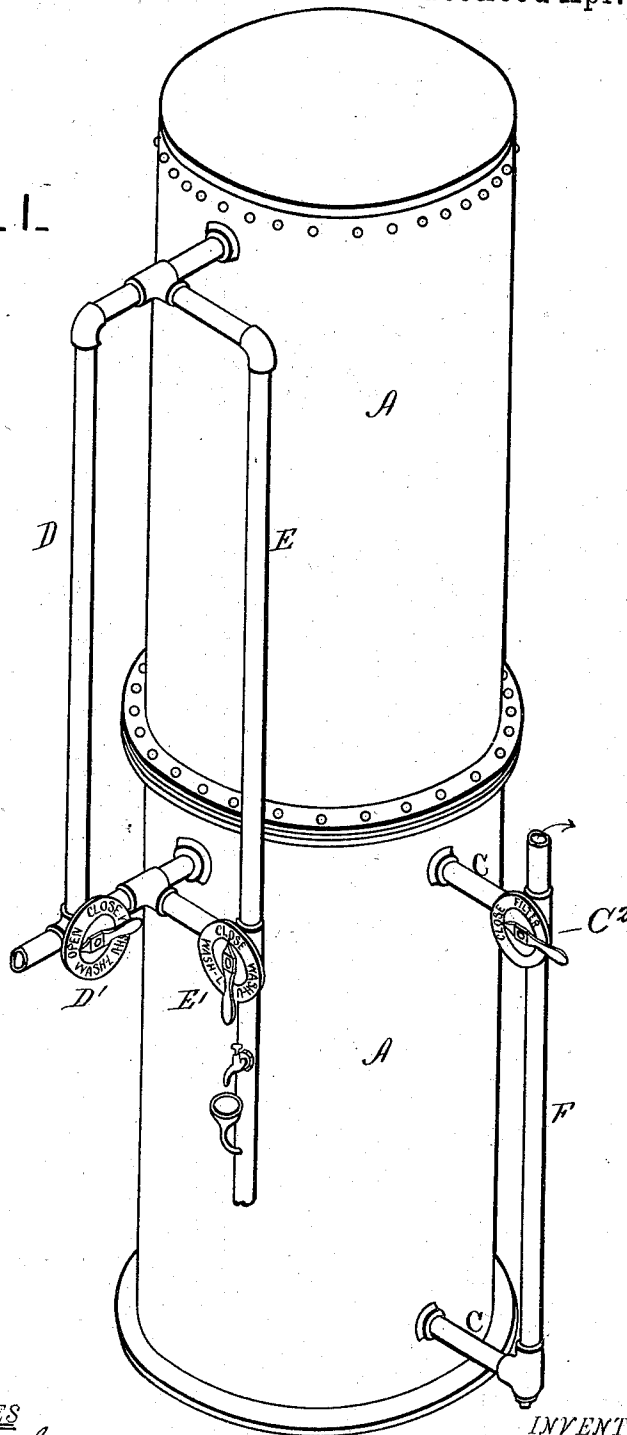

WITNESSES
F. Clough.
D. W. Bradford

INVENTOR
Junius A. Bowden
By W. C. Leggett.
 Attorneys.

J. A. BOWDEN.
FILTER.

No. 559,096.

Patented Apr. 28, 1896.

FIG. 2.

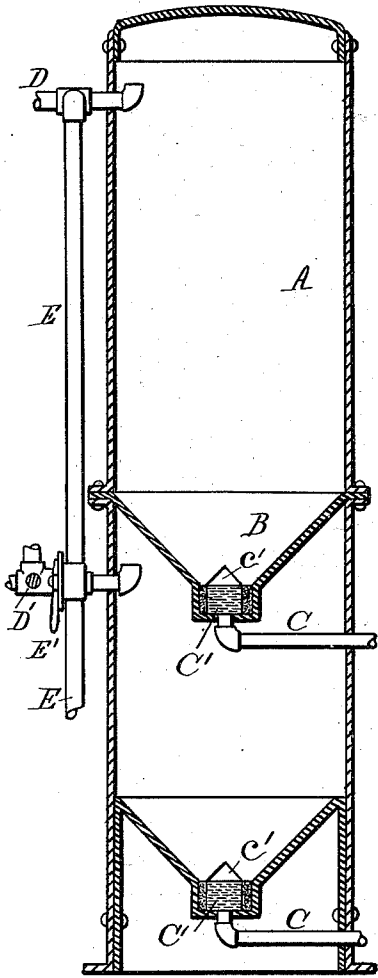
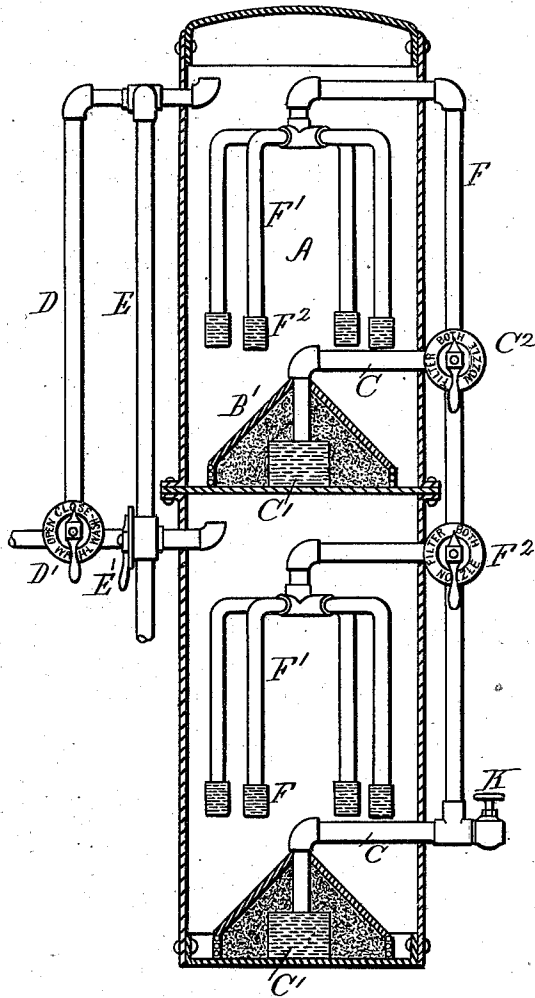

FIG. 3.



WITNESSES
F. Clough.
D. W. Bradford

INVENTOR
Junius A. Bowden
By W. W. Feggett,
 Attorneys.

J. A. BOWDEN.
FILTER.

No. 559,096.

Patented Apr. 28, 1896.

Fig. 3. A

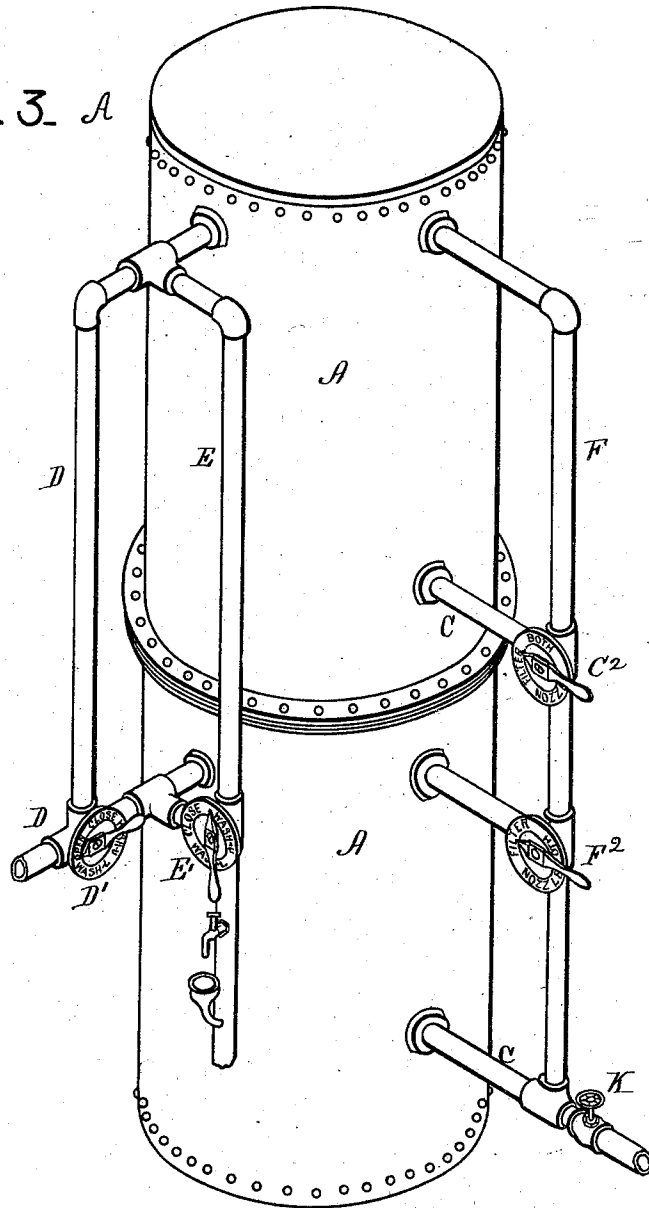

WITNESSES

F. Cloughie
D. W. Bradford

INVENTOR

J. A. Bowden
By W. W. Jaggard
Attorneys.

J. A. BOWDEN.
FILTER.

No. 559,096.

Patented Apr. 28, 1896.

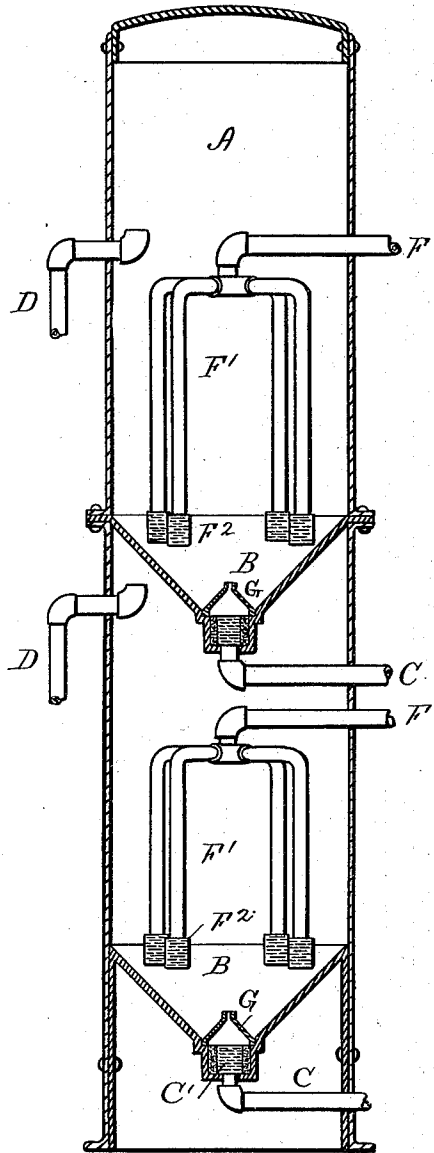

Fig. 4.

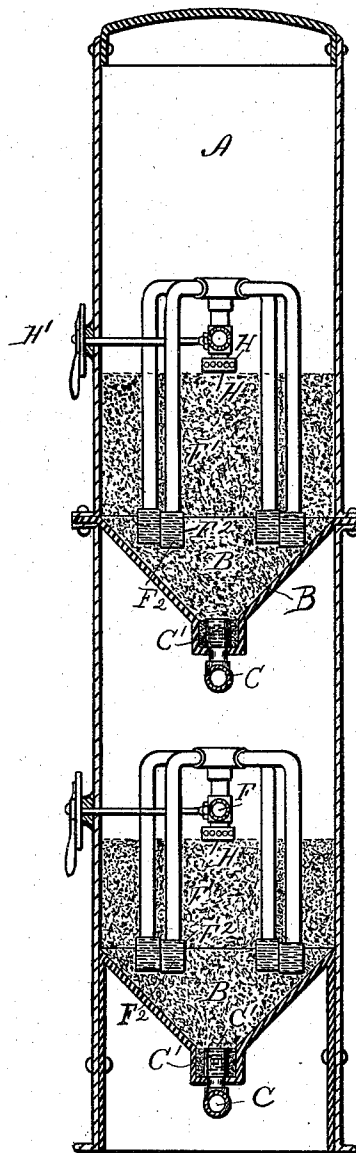

Fig. 5.

WITNESSES

F. Blough,
D. W. Bradford

INVENTOR

Junius A. Bowden
B. W. W. Leggett,
Attorneys.

UNITED STATES PATENT OFFICE.

JUNIUS A. BOWDEN, OF DETROIT, MICHIGAN.

FILTER.

SPECIFICATION forming part of Letters Patent No. 559,096, dated April 28, 1896.

Application filed March 9, 1891. Serial No. 384,280. (No model.)

To all whom it may concern:

Be it known that I, JUNIUS A. BOWDEN, a citizen of the United States, residing at Detroit, county of Wayne, State of Michigan, have invented a certain new and useful Improvement in Filters; and I declare the following to be a full, clear, and exact description of the invention, such as will enable others skilled in the art to which it pertains to make and use the same, reference being had to the accompanying drawings, which form a part of this specification.

In the drawings, Figure 1 is a perspective view of a filter embodying my invention adapted to be operated by three valves. Fig. 2 is a sectional view of the same. Fig. 3 is a sectional view of a variation in which cleansing-strainers are employed. Fig. 3^A is a perspective view of the same. Fig. 4 is a sectional view of a variation in which the device substantially as shown in Fig. 2 is provided with washing-strainers. Fig. 5 is a view similar to Fig. 4, showing slight variations in the structure and illustrating a surface-wash with means for controlling the same.

It is the purpose of my invention to produce an improved construction of filter, the said improvements consisting, essentially, in the following features: first, the provision of an inverted conical bottom with a filtered-water outlet leading into the same at the lower extremity or apex of the said inverted cone, whereby perfect circulation from the water-inlet to the water-outlet is maintained through all parts of the filter, and whereby, when the said filtered-water conduit is utilized for passing a current of filtered water in the reverse direction through the filter-bed for washing the same, it will lift and agitate the material of the filter-bed along those courses of least resistance, and the adjacent material will settle down and be directed by said inverted conical bottom to the apex of the cone, where it will pass up through the body of and will be caught up and washed, and so on until the filter-bed is thoroughly cleansed; secondly, the provision in a filter, for assisting in washing the same, of a series of depending pipes extending from above the filter-bed down vertically below the surface of the same and terminated at their lower ends with hori-

zontally-slitted nozzles, whereby the wash-water may be discharged therefrom in horizontal strata and assist in loosening the bed. 55

In carrying out my invention, A is the shell or case. B is its inverted conical base.

C is the filtered-water outlet.

D is the water-inlet conduit.

E is the drain-pipe when the current is reversed through the filter for washing the same. 60

F is a filtered-water-inlet pipe connected with the depending pipes F' for use in washing the filter-bed.

C' is a horizontal slitted strainer at the inner extremity of the filtered-water-outlet conduit. 65

F² represents similar strainers at the lower extremities of the pipes F'.

D', E', F², C², and H' are three-way valves. 70

In Fig. 2 the inverted conical base B and filtered-water outlet C are employed in connection with the water-inlet D and drain E.

It is apparent that in the use of this filter the water passing down through the filter-bed will be directed to the apex of the cone from every part of the filter-bed, so that no part of the filter-bed will be subjected to a free current through it while other parts are not so active. The result of this construction is to cause all parts of the filter-bed to act with substantial uniformity. On the other hand, when it is desired to cleanse the filter-bed, 75

filtered water may be reversed through the conduit C. This produces a strong upward flow through the filter-bed, lifting and agitating the mass so that the water will take naturally the course of least resistance; but the filter-bed bearing down upon the inverted conical surface B will be constantly shifted to this apex or lower end of the cone and come under influence of the stream of wash-water. 80

So, also, water entering in this way at the bottom or apex of the cone will at one moment find a path of least resistance in one direction, while by the shifting of the material of the filter-bed this path may be quite different at the next moment, and so by shifting its course, due to this constant shifting of the filter-bed, the stream is caused to work up through and wash all portions of the filter-bed and drive its impurities to the top of the bed. 85
When thus used to wash either filter-bed, the inlet-water would be turned off from that bed 90
100

by the three-way valve D' (shown in Fig. 1) and the drain-pipe E opened by the three-way valve E', the wash-water being permitted to escape through this passage.

5 This filter may be made single or it may be made double. If made double, the lower part is constructed in all particulars substantially the same as the upper part, and it is manifest that either part may be used as a filter, or that
10 either part may be washed independently of the other, or both may be used as a filter by the proper manipulation of the three-way valves.

A filter provided with an inverted conical
15 bottom may rely wholly for washing upon the reverse current through the filtered-water-outlet pipe, or it may have in aid thereof an additional washing device consisting of depending pipes F', provided with the strainers, and preferably horizontally-slitted strainers
20 F² at the base of each said upright pipe. These depend well down toward the bottom of the filter-bed, and by the three-way valve C² filtered water from the lower filter may be caused
25 to pass down through said depending pipes and out through said strainers, thus thoroughly agitating the adjacent portions of the filter-bed and washing out its accumulation, and so they will greatly assist the filtered
30 water which may be passed through the conduit C in washing the filter-bed. I would not be limited in the use of these depending pipes to a filter with an inverted conical base, for they may be used with advantage in any kind
35 of a filter. Thus, as shown in Fig. 3, the base of the filter-bed may be a right cone instead of an inverted cone. This construction, however, is not so desirable, because filtered water when reversed through the conduit C is caused
40 to separate and expend its energy before escaping beneath the base of the cone into the body of the filter-bed and does not, therefore, act so thoroughly to lift and agitate the filter-bed, and the flow of water is apt to be at the sides alone, without reaching and cleansing
45 the middle of the bed.

I do not limit myself to any particular construction at the inner end of the conduit C. There may be simply a plain open end, or, as
50 shown in Fig. 2, there may be a strainer free upon its inside and with gravel or granular filtering material about its immediate exterior, and be provided with a small deflecting-cone c' at its top, or, as shown in Fig. 5, there may be
55 simply a slitted or perforated strainer without the said conical top, or, as shown in Fig. 4, this conical top may be in the form of an ordinary nozzle G and permit filtered water to pass down only through the said nozzle, thus
60 shielding the strainer beneath from the direct pressure of the filter-bed, and this form might be used to good advantage without the strainer beneath it, since but little of the material of the filter-bed would be apt to
65 drift down through the said small nozzle-opening. All these constructions are mere varia-

tions in the method of arrangement at the inner end of the filtered-water outlet, and any of them might be employed without departing from the spirit of my invention.

The three-way valves may, as shown in the different figures, be provided with indicating-disks, indicating the effect produced when the valve is turned into any particular position.

In the contrivance shown in Fig. 3 four
75 three-way valves are employed. The valves D' and K being both in their open condition and E' closed, water would flow up through D into the upper filter and simultaneously
80 into the lower filter, and with the valves C² and K in proper position filtered water would be drawn off from both and the depending wash-water pipes would be closed, or the
85 valve D' may be turned to close the inflow of water. Then by suitably adjusting the valve C², so as to close off F and to open the passage from the pipe C of the upper filter, and opening the valve E' to make a free
90 passage to the drain, and also arranging the valve F² to leave a free up-and-down passage while the depending pipes F' are closed off, by admitting the filtered water through the
95 valve K from any external supply both the lower and upper filters are cleansed and the wash-water will flow off through E to the drain. So, also, the valves C² and F² may be
100 turned to simultaneously admit water down through the depending pipes F' and strainers F² in both the lower and upper filter; or by arranging the valve D' so as to close off the
105 flow into the upper filter, still maintaining the flow into the lower filter, and closing the valve K, water would enter the lower filter, pass down through the same, thence out and
110 up through the pipe F, and in a reverse direction through the upper filter, and thence out through the drain E, so that water being filtered through the lower section might serve
115 to simultaneously wash the upper section, or by a manifest adjustment of the valves the upper section might be filtering and the water therefrom be made to simultaneously wash
the lower section and pass thence to the drain. The arrangement of these valves and conduits
3^A in connection with Fig. 3.

In the device shown in Figs. 1 and 2 only
120 three of the three-way valves are employed. In this contrivance water entering the upper and lower filters passes out through the filtered-water conduits C from both filters.
125 Then by adjusting the valve D' so as to admit water into the upper filter and cut the flow-off into the lower filter and adjusting the valve C², Fig. 1, to cut off the outflow through the filtered-water-outlet pipe and leaving the communication free through both the pipes
130 C, it is manifest that water entering the upper filter will pass down through its filter-bed and the filtered water therefrom will pass down and enter at the base of the lower filter,

wash its filter-bed, and escape through the drain-pipe E; or, leaving the valve C² and E' in their present position and adjusting the valve D' so as to cut off the inflow into the upper filter and maintain a flow into the lower filter, the water entering the lower filter will pass downward through its filter-bed, and this filtered water will rise and be discharged into the base of the upper filter, will wash its filter-bed, and escape through the drain-pipe E.

What I claim is—

1. A filter provided with an inverted conical base, with a filtered-water conduit leading from its apex, said conduit provided with a strainer and a supporting-surface immediately above said strainer, said surface provided with an ordinary nozzle through which the filtered water may pass when filtering, and through which the wash-water may enter in a solid stream when washing the filter-bed, substantially as described.

2. In a filter, the combination of an inclined base, a wash-water inlet arranged to permit the inflow of wash-water in a jet extending upward from the bottom of said inclined base, one or more wash-water pipes extending from above the surface of said filter-bed to, or nearly to, the top of said incline, and arranged to discharge across the said stream of water,

rising upward from said wash-water inlet at the base, substantially as and for the purpose described.

3. In a filter, the combination with a casing divided into compartments, one above the other, each compartment having conical-shaped bottoms, conduits leading into the apex of the cones, nozzles on the ends of the conduits, a filter-bed surrounding the nozzles, inlets for both compartments, and valves for the inlet and conduits, substantially as described.

4. In a filter, the combination with a casing divided into compartments, one above the other, each compartment having inverted conical-shaped bottoms, conduits leading into the apex of the cones, nozzles on the ends of the conduits, a filter-bed surrounding the nozzles, inlets for both compartments, valves for the inlet-conduits, and a surface-wash for the filter-bed in each compartment consisting of pipes having lateral discharge-openings, substantially as described.

In testimony whereof I sign this specification in the presence of two witnesses.

JUNIUS A. BOWDEN.

Witnesses:

MARION A. REEVE,
WELLS W. LEGGETT.