

No. 821,967.

PATENTED MAY 29, 1906.

J. STRAUSS.
CARRYING HANDLE.
APPLICATION FILED OCT. 4, 1905.

Fig. 1.

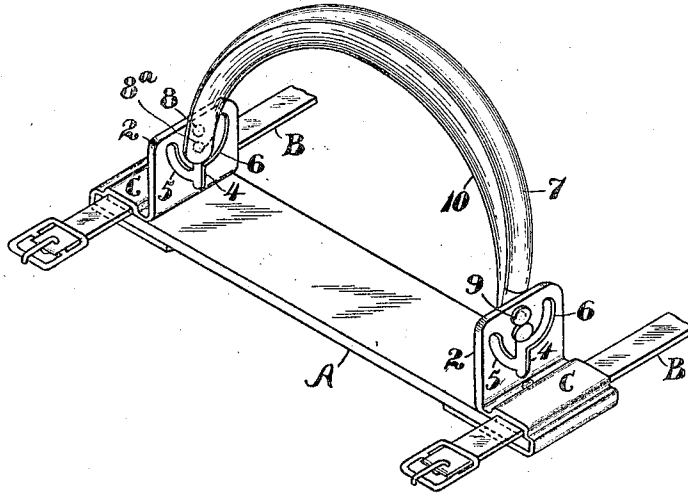
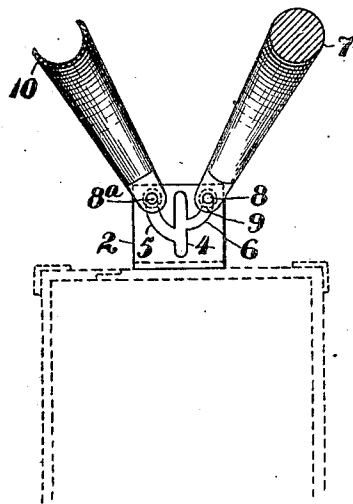

Fig. 2.



Witnesses:-
F. C. Griedner
J. A. Morse

Inventor
Julius Strauss
By Geo. H. Strong

UNITED STATES PATENT OFFICE.

JULIUS STRAUSS, OF ASTORIA, OREGON.

CARRYING-HANDLE.

No. 821,967.

Specification of Letters Patent.

Patented May 29, 1906.

Application filed October 4, 1905. Serial No. 281,261.

To all whom it may concern:

Be it known that I, JULIUS STRAUSS, a citizen of the United States, residing at Astoria, in the county of Clatsop and State of Oregon, have invented new and useful Improvements in Carrying-Handles, of which the following is a specification.

My invention relates to a handle which is designed for the carrying of suit-cases, telescope-baskets, or like articles or as an attachment to what are known as "shawl-straps."

It consists of the combination of parts whereby the handle may be separated into two parts capable of being gripped by individuals upon opposite sides, or it may be united to form a unitary structure in the form of a single handle.

It also consists in details of construction, which will be more fully explained by reference to the accompanying drawings, in which—

Figure 1 is a perspective view of my handles assembled. Fig. 2 is a sectional view of same, showing handles separated.

It is the object of my invention to provide a handle which may be either used as a single handle or in case where the package is heavy and it is desirable to divide the weight between two individuals it may be separated, so as to provide two grips projecting on either side, so that two individuals may take hold of the grips and the weight can be comfortably balanced and carried between them. It will be understood that such a handle may be permanently attached to a suit-case, or it may be made a part of a device, it having straps which pass around the package and a bar to which these straps and the handle are attached.

In this construction, A is a bar which may be made of wood or other desired material and which is usually covered with leather to make it more ornamental. The straps B pass through suitable keepers C upon the bar and may pass thence around the bag or other package to be carried. 2 represents plates projecting upwardly from this bar, or in case the device is a permanent attachment for a case or other package these plates are secured to the part to be carried. In the present illustration these plates are bent outwardly, thence upwardly to form the keepers C, thence over the ends of the arms A, thence returned beneath the bar to a point just below the plates 2, and a single rivet passing through the top and bottom portion and through the part A will hold

each of these plates in position. These plates are slotted as follows: 4 is a vertical slot substantially central of the plate and has an outwardly-curved slot intersecting the lower part of the slot 4, and 6 is another outwardly-curved slot intersecting the slot 4 at a point slightly above the slot 5, the plates at each end having the same character of slots made in them.

7 is the main handle, which is of the usual style and may be leather-covered, and at its ends it has projecting pins 8, adapted to enter and slide within the slots 4 and 6. Heads 9 upon the outer ends of these pins retain them in place and prevent their being pulled out of the slots.

10 is a segmental handle having a curvature longitudinally and transversely corresponding with the inner side of the handle 7, and when the two are fitted together the segmental handle 10 incloses and fits closely around the lower part of the handle 7, extending far enough up on its sides so as to practically coincide with it. This portion 10 may be made of metal and of sufficient rigidity to be used separately when required. The ends of this handle have also pins extending from them into the slots 4 and 5, as previously described, and heads upon the ends of the pins to prevent their being withdrawn.

The operation of the device will then be as follows: When the handle is to be used as a single handle, the pins 8 of the upper portion 7 of the handle are drawn up into the upper part of the slot 4. The pins 8^a of the segmental portion of the handle are then likewise drawn up into the slot beneath the pins 8, and in so doing the segmental handle 10 will be snugly fitted and will coincide with the handle 7, thus making a handle which can be used by a single individual upon a package which is not too heavy. When it is desired to distribute the load between two individuals, the lower handle 10 is pushed down, and its pins 8^a slide down to the bottom of the slot 4, thence may be drawn up into the slots 5, divergent to one side of the slot 4. The handle 7 may then be pushed down in the slot 4, and when it arrives opposite the divergent slots 6 the pins 8 may likewise be drawn into these slots, the handle 7 thus diverging to one side of a vertical plane and the handle 10 to the opposite side of such a plane. The handles will thus be sufficiently separated, so that each of them may be grasped by the hand from opposite sides

and the load evenly suspended between the carriers.

It will be noted that the lower ends of the slots 5 intersect the vertical slot 4 at a point sufficiently below the intersection of the slots 6 with 4 so that there will be a tongue projecting down between the slots 4 and 5 of sufficient length to prevent any opening so large that the heads 9 might be withdrawn through it. Such an opening would be produced if all the slots intersected at the same point.

Having thus described my invention, what I claim, and desire to secure by Letters Patent, is—

1. A package-carrying handle comprising two separable parts, shiftable pivotal connections for each of said parts, and means for attaching said parts to the package to be carried.

2. A package-carrying handle comprising two separable parts, independent pivots for each of said parts, means whereby the position of said pivots may be varied to allow the pivots to stand vertically in line and to be separated transversely, and means for attaching said parts to the package to be carried.

3. In a carrying-handle two independently-pivoted parts one of said parts having a convex gripping-surface and the other part having a concaved gripping-surface to receive said convex surface whereby the two parts of the handle unite to form a single handle.

4. In a carrying-handle, two parts, one part being substantially circular in cross-section, the other part segmental and adapted to fit the lower part of the first-named section, pins projecting outwardly from the ends of each of the handle members, and slotted plates through which said pins pass and within which they are movable to separate

the handle members divergently from each other.

5. In a carrying-handle, two parts, one substantially circular in cross-section, and the other segmental and adapted to fit the lower part of the first-named portion, pins projecting from the ends of each of said handle parts, a plate at each end of the handle parts said plate having a vertical slot in which said pins lie one above the other when the handle is united to form a single structure, and having slots divergent from the vertical slot into which the handles of each of the sections may be transferred to separate the handle-sections divergently from each other to form separate grips.

6. A handle composed of two curved independent sections, the lowermost of said sections being segmental in transverse section, and the uppermost part being circular and adapted to fit within the segmental portion, pins projecting from the ends of each of the handle-sections and having retaining-heads upon the outer ends, plates having vertical slots within which the pins of both handle-sections may lie one above the other when said sections are united into one, said plates having, also, slots divergent upon opposite sides of the vertical slots and opening thereinto, the slots on one side intersecting the vertical slots above those upon the opposite side, and each capable of receiving the pins of one portion of the handle which is thereby separated into two distinct parts.

In testimony whereof I have hereunto set my hand in presence of two subscribing witnesses.

JULIUS STRAUSS.

Witnesses:

S. H. NOURSE,
HENRY P. TRICOU.