

(19) World Intellectual Property Organization
International Bureau



(43) International Publication Date
9 November 2006 (09.11.2006)

PCT

(10) International Publication Number
WO 2006/116850 A1

- (51) International Patent Classification:
A61F 2/44 (2006.01)
- (21) International Application Number:
PCT/CA2006/000675
- (22) International Filing Date: 2 May 2006 (02.05.2006)
- (25) Filing Language: English
- (26) Publication Language: English
- (30) Priority Data:
60/594,727 2 May 2005 (02.05.2005) US
- (71) Applicant (for all designated States except US): **KINETIC SPINE TECHNOLOGIES INC.** [CA/CA];
Foothills Hospital, 1403 - 29th Street N.w., Calgary,
Alberta T2N 2T9 (CA).
- (72) Inventors; and
- (75) Inventors/Applicants (for US only): **HURLBERT, R. John** [CA/CA]; 36 Church Ranches Close, Calgary,
Alberta T3R 1C1 (CA). **SEKHON, Lali** [US/US]; 4140
Sedge Street, Fremont, California 94555 (US). **DUP-
LESSIS, Stephan J.** [CA/CA]; 303 Church Ranches Rise,
Calgary, Alberta T3R 1B1 (CA).
- (74) Agents: **CHARI, Santosh K.** et al.; Blake, Cassels &
Graydon LLP., Suite 2800, Box 25, Commerce Court West,
199 Bay Street, Toronto, Ontario M5L 1A9 (CA).

- (81) Designated States (unless otherwise indicated, for every kind of national protection available): AE, AG, AL, AM, AT, AU, AZ, BA, BB, BG, BR, BW, BY, BZ, CA, CH, CN, CO, CR, CU, CZ, DE, DK, DM, DZ, EC, EE, EG, ES, FI, GB, GD, GE, GH, GM, HR, HU, ID, IL, IN, IS, JP, KE, KG, KM, KN, KP, KR, KZ, LC, LK, LR, LS, LT, LU, LV, LY, MA, MD, MG, MK, MN, MW, MX, MZ, NA, NG, NI, NO, NZ, OM, PG, PH, PL, PT, RO, RU, SC, SD, SE, SG, SK, SL, SM, SY, TJ, TM, TN, TR, TT, TZ, UA, UG, US, UZ, VC, VN, YU, ZA, ZM, ZW.
- (84) Designated States (unless otherwise indicated, for every kind of regional protection available): ARIPO (BW, GH, GM, KE, LS, MW, MZ, NA, SD, SL, SZ, TZ, UG, ZM, ZW), Eurasian (AM, AZ, BY, KG, KZ, MD, RU, TJ, TM), European (AT, BE, BG, CH, CY, CZ, DE, DK, EE, ES, FI, FR, GB, GR, HU, IE, IS, IT, LT, LU, LV, MC, NL, PL, PT, RO, SE, SI, SK, TR), OAPI (BF, BJ, CF, CG, CI, CM, GA, GN, GQ, GW, ML, MR, NE, SN, TD, TG).

Published:

- with international search report
- before the expiration of the time limit for amending the claims and to be republished in the event of receipt of amendments

For two-letter codes and other abbreviations, refer to the "Guidance Notes on Codes and Abbreviations" appearing at the beginning of each regular issue of the PCT Gazette.

(54) Title: ARTIFICIAL VETEBRAL BODY

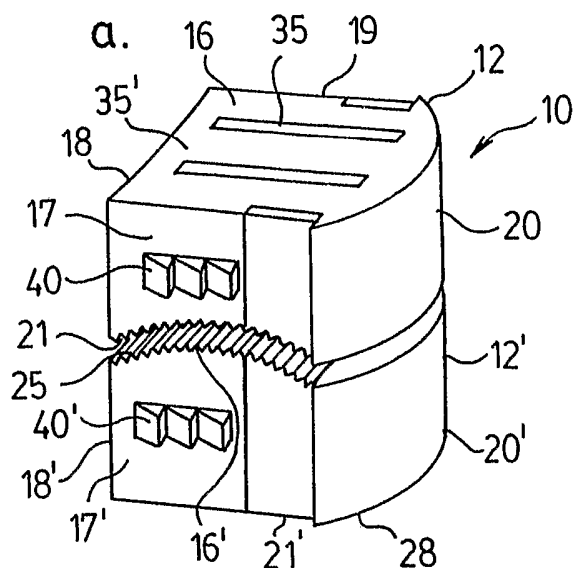

(57) Abstract: An artificial vertebral body includes superior and inferior portions wherein said portions are positively engageable. The relative positions of the superior and inferior portions are variable about the sagittal plane. The artificial vertebral body also includes one or more means for engaging adjacent spinal structures to establish placement of the body in the spine.

WO 2006/116850 A1

ARTIFICIAL VERTEBRAL BODY**FIELD OF THE INVENTION**

[0001] The present invention generally relates to devices and surgical methods for the treatment of various types of spinal pathologies. More specifically, the present invention is directed to vertebral body replacements and procedures for performing such replacements.

BACKGROUND OF THE INVENTION

[0002] The spine has four natural curves; two are lordotic and two are kyphotic. The cervical and lumbar curves are lordotic, while the thoracic and sacral curves are kyphotic. While these curves of the spine help to distribute mechanical stress as the body moves, conditions may develop where there are extreme curvatures. For example, while the upper or thoracic region of the spine is normally curved forward, if the curve exceeds 50°, it is considered abnormal or “kyphotic”. Lordosis is an abnormal increase in the normal lordotic curvature of the lumbar spine; excessive lordosis may cause an extreme inward curve in the lower back.

[0003] The techniques, instrumentation and implants for treating conditions or abnormalities of the spine have adapted to address many forms of spinal injury and deformities that can occur due to trauma, disease or congenital effects. One type of spinal deformity, a kyphosis, involves a prolapse of the vertebral column towards the front of the body, often caused by the destruction of the vertebral body itself.

[0004] Several events can distort the spine leading to conditions like accentuated kyphosis or hyper-lordosis. Because the natural tendency of the spine is to curve, a weakness in any component thereof or the supporting structures may lead to such conditions. For example, a diseased thoracic vertebra will ordinarily crumble its forward edge first, increasing the kyphotic curve. Conditions that can do this include cancer, tuberculosis, Scheuermann's disease, and certain kinds of arthritis. Healthy vertebra can fracture forward with rapid deceleration injuries, such as in car crashes. Osteoporosis may also contribute to such conditions. As result of any of these conditions and their underlying etiology, it may be necessary to consider vertebral body replacement.

1 [0005] Where it is necessary to replace at least a portion of a vertebral body for the
2 reasons noted above, previous techniques have involved reconstruction of that portion of the
3 vertebral body with a polymerizable paste or a bone graft which is frequently modelled to
4 give it the shape of intact vertebral body. Frequently, autologous bone, such as that extracted
5 from the ilium, is used to bridge the space. The polymerizable paste can include a PMMA
6 bone cement. Various artificial apparatus have also been developed to address structural
7 failure of various parts of the spinal column.

8 [0006] While there is a need for the replacement of injured and/or diseased vertebral
9 bodies, which cause, or are a result of, various spinal diseases, previous apparatuses and
10 techniques have, however, several drawbacks. They have been fashioned to provide support
11 between adjacent vertebral bodies by creating a fusion across the diseased segment thereby
12 eliminating movement in the spinal column. In addition to reducing range of movement in
13 the spine this can also cause premature degeneration of spinal joints above and below the
14 fusion site. They also require additional instrumentation at the front or back of the spine to
15 secure them in place.

16 [0007] The present invention, in one aspect, provides an artificial vertebral body that
17 obviates or mitigates at least some of the deficiencies of previous apparatuses and techniques.

18 SUMMARY OF THE INVENTION

19 [0008] In one aspect, the invention provides an vertebral body for replacing a naturally
20 occurring a vertebral body in a spine.

21 [0009] Thus, in one aspect, the invention provides an artificial vertebral body comprising:

22 - a superior portion and an inferior portion, each of the superior and inferior portions
23 having superior and inferior surfaces and lateral sides;

24 - the superior surface of the inferior portion being in contact and in positive
25 engagement with the inferior surface of the superior portion;

26 - the superior surface of the superior portion and the inferior surface of the inferior
27 portion having one or more engagement means to engage adjacent spinal structures.

1 BRIEF DESCRIPTION OF THE DRAWINGS

2 [0010] Various objects, features and attendant advantages of the present invention will
3 become more fully appreciated and better understood when considered in conjunction with
4 the accompanying drawings, in which like reference characters designate the same or similar
5 parts throughout the several views.

6 [0011] Figures 1(a) to (g) show various views of embodiments of the present invention.

7 [0012] Figure 2 shows a side view of an embodiment of the present invention.

8 [0013] Figure 3 shows a perspective view of an embodiment of the present invention.

9 [0014] Figures 4(a) to (d) show various views of embodiments of the present invention.

10 [0015] Figures 5(a) to (c) show various views of embodiments of the present invention..

11 [0016] Figures 6(a) to (c) show various views of embodiments of the present invention.

12 [0017] Figure 7 shows side views of an embodiment of the present invention.

13 [0018] Figure 8 shows side views of an embodiment of the present invention.

14 [0019] Figure 9 shows side view of an embodiment of the present invention.

15 DETAILED DESCRIPTION OF THE INVENTION

16 [0020] In order that the invention may be more fully understood, it will now be described,
17 by way of example, with reference to the accompanying drawings in which Figures 1 through
18 9 illustrate embodiments of the present invention.

19 [0021] In the description and drawings herein, and unless noted otherwise, when
20 discussing anatomical plans of view, it will be understood that the terms "front" and "back"
21 shall be used to refer to the front and back in the coronal or frontal plane. The terms "left"
22 and "right" shall be used to refer to left and right in the sagittal or lateral plane. The terms
23 "up" and "down" shall be used to refer to up and down in the axial transverse. It will be
24 understood that a reference to "medial" shall refer towards the midline of a body. It will be
25 understood that a reference to "lateral" shall refer to away from the midline of a body. It will
26 be understood that a reference to "inferior" shall refer to lower, below or down and

1 “superior” shall refer to upper, above or up. It will be further understood that a reference to
2 “anterior” shall refer to front and “posterior” shall refer to the rear or back.

3 **[0022]** The present invention provides an artificial vertebral body that can be used to
4 replace at least a portion of vertebral bodies in different regions of the spinal column or,
5 alternatively, the entire vertebral body or corpus (e.g. the drum shaped structure at the
6 anterior end of the vertebrae) can be replaced. Specifically, different embodiments of the
7 vertebral body according to the present invention may be used in the lumbar, thoracic, and
8 cervical spine regions.

9 **[0023]** Figure 1(a) illustrates an artificial vertebral body 10 in accordance with an
10 embodiment of the present invention. Vertebral body 10 has a superior portion 12 and an
11 inferior portion 12'. As shown in Figure 1(e), portions 12 and 12' have a generally wedged,
12 trapezoid shape to approximate configuration of a normal vertebral body in a lordotic spine.
13 As shown in Figure 1(a), the superior element 12 includes an upper or superior surface 16, a
14 lower inferior surface 21, anterior and posterior surfaces 20 and 18, respectively and left and
15 right lateral side surfaces 19 and 17, respectively. Similar surfaces are provided on portion
16 12' except identified as 16', 17', 18', 19', 20' and 21', as shown in Figures 1 and 3. Anterior
17 surface 20 of portion 12 may extend beyond the anterior surface 20' of portion 12', the
18 function of which will be described below.

19 **[0024]** Portions 12 and 12' are affixed together by at least one fastener. As shown in
20 Figure 1(b) and (e), there are three fasteners in the form of screws 22, 24 and 26.

21 **[0025]** Anterior surface 20 is generally convex, while inferior surface 21 is generally
22 concave. Posterior surface 18 is also concave. The anterior surface or side 20, after insertion
23 into the spinal column, is generally facing anteriorly, namely facing towards the front of the
24 body, while the posterior side 18 is positioned towards the spinal cord contained within the
25 spinal column (towards the back of the body). The superior surface 16 of the vertebral body
26 may be of smaller dimensions than the inferior surface 21. Similarly the superior surface 16'
27 may be of smaller dimensions than the inferior surface 21', causing asymmetry between upper
28 and lower surfaces, more closely approximating normal anatomical relationships in the
29 cervical spine. This asymmetry may be less pronounced or reversed in cases where the
30 invention is for use in the thoracic or lumbar spine regions.

1 [0026] Portion 12 is provided with overhang 28 of the convex surface 20 with respect to
2 the sides of vertebral body. Overhang on the sides of the anterior (or front) curved surface of
3 the vertebral body produces an edge of approximately 90 degrees to the true lateral wall of
4 the vertebral body. Portion 12' is similarly shaped. Over hang 28 prevents posterior
5 migration of portion 12 into the spinal cord upon insertion thereof into a surgical
6 vertebrectomy defect. A smooth anterior surface may also reduce postoperative dysphagia by
7 reducing adhesions between the implant and the posterior pharyngeal wall.

8 [0027] Portions 12 and 12' are joined by way of a toothed or textured curved locking
9 mechanism. Such mechanism is formed with the inferior surface of portion 12 and the
10 superior surface of portion 12' having complementary toothed surfaces. In this manner,
11 when the portions 12 and 12' are positioned together, the toothed surfaces engage to prevent
12 further movement between such surfaces. This locking mechanism is tightened by at least
13 one of the fasteners affixing portions 12 and 12' together. In one embodiment of the present
14 invention, there is provided, as shown in Figures 1(b) and (e), screws 22, 24 and 26 recessed
15 into the midline of the superior surface of portion 12. Loosening of the locking mechanism
16 allows adjustment of the angular relationship of upper portion 12 to the lower portion 12' of
17 vertebral body 10. In such a manner, upper surface 16 of vertebral body 10 can be made
18 parallel to lower surface 21' or the two surfaces can be angled or off-set with respect to each
19 other. Figure 1(f) shows how surfaces can be offset. In addition, Figures 7 to 9 show how
20 the portions can be off set. This accommodates angular variations of lordosis and kyphosis
21 amongst different areas of the spine and variations in the spines of different people.

22 [0028] In one embodiment, the locking mechanism consists of adjustment fasteners 22,
23 24 and 26 provided generally in the midline of portion 12 and recessed into superior surface
24 16 of portion 12. As seen in Figure 1(e), a locking plate 25 is provided between portions 12
25 and 12' and is positioned adjacent to the convex curve of the inferior portion 12' of the
26 vertebral body. The ends of screws 22, 24, and 26 engage locking plate 25. Locking plate 25
27 receives the screws 22, 24 and 26 and acts like a "blind nut", which receives a screw that can
28 be subsequently tightened without the nut spinning. Tightening screws 22, 24 and/or 26 into
29 locking plate 25 cinches it up against the inside of 12' which in turn then engages against the
30 teeth 27 of toothed or textured curved surface 21 of portion 12. Teeth 27 are shown in
31 greater detail in Figure 4(a). Pressure between the screw heads 22, 24, and 25 against portion
32 12, and pressure from the locking plate against portion 12' keep the teeth engaged between

1 12 and 12' preventing the vertebral body from changing shape. Locking plate 25 may be
2 sufficiently wide or as sufficiently long so as to fit within portion 12'. Locking plate 25 is
3 provided against toothed or textured curved surface 21 so as to allow angular motion of
4 portion 12 between angled posterior and anterior positions which allows for the adjustment of
5 the angular relationship of upper portion 12 to the lower portion 12' of vertebral body 10. As
6 will be understood, such adjustment is made by loosening screws 22, 24 and 26, disengaging
7 the toothed surfaces of the portions 12 and 12' and moving such portions relative to one
8 another to achieve the desired placement.

9 **[0029]** As shown in Figure 1(e), superior surface 16' of lower portion 12' is adapted to
10 mate with the curved inferior surface 21 of upper portion 12. The mating of surface 16 and
11 surface 21 provided for an interface that separates the upper portion 12 of vertebral body 10
12 from lower portion 12'. Changes in angle necessitate a degree of translation of the upper half
13 with respect to the lower half of the artificial vertebral body.

14 **[0030]** In a further embodiment of the present invention, as shown in Figure 1(f), the
15 artificial vertebral body of the invention may include a third portion 30 provided between the
16 portions 12 and 12' in order to produce pure translational adjustments of portion 12 of the
17 vertebral body 10'. As shown in Figure 1(f), the third portion 30 provides an additional
18 interface between the portions 12 and 12'. As shown in Figure 1(f) and Figure 7, it will be
19 appreciated that the addition of portion 30 allows the creation of a more kyphotic angle in the
20 vertebral implant without the large degree of offset required in the "two component" version.
21 As shown in Figure 1(f), the radius of the curvature is less with the embodiment
22 encompassing three portions 12, 12' and 30, making the curve sharper than in the two piece
23 design. It will be understood, however, that the radius can be varied depending on the
24 application. Similarly the dimensions of the three components shown in 10' (Figure 1(f)),
25 namely portions 12, 12' and 30 may also be varied in length, width, and height.

26 **[0031]** Third portion 30 has an upper or superior surface 30' and a lower or inferior
27 surface 30'', which engage with surfaces 21 and 16' respectively. Upper surface 30' is
28 generally flat, while lower surface 30'' is generally curved to mate with superior surface 16'
29 of portion 12'. It will be understood in such an embodiment that inferior surface 21 of
30 portion 12 would be need to be configured to mate with surface 30'. This allows the artificial
31 vertebral body to take on a more skewed and kyphotic shape to treat conditions of more

1 severe malalignment. In this embodiment, vertebral body 10' consists of three elements or
2 portions 12, 12' and 30. These elements are affixed by two sets of locking mechanisms
3 similar to those described above through toothed or textured surfaces that interact to form two
4 interfaces. One portion of body 10 translates backwards or forwards on a middle portion. As
5 provided in Figure 1(e), portion 12 can move anteriorly or posteriorly as shown by arrows A.
6 Another portion of body 10 angles backwards and forwards on the middle section as well. As
7 provided in Figure 1(e), portion 30 can move as provided by arrows B. Adjustment screws
8 are recessed from the exposed upper and lower surfaces of the body lock the pieces together
9 in their desired configuration.

10 **[0032]** As shown in Figures 1(e) and 2, the artificial vertebral body of the present
11 invention can integrate or co-operate with an artificial intervertebral disc such as a disc that is
12 described in applicants' co-pending application number 60/594,732 (the entire contents of
13 which is incorporated herein by reference). As described in such application, an artificial
14 disc is provided with one or more "stabilising keels" on at least one of its outer surfaces. As
15 shown in Figures 1(a), (b), and (d) there are provided openings 35 and 36 on surface 16 as
16 well as opening 35' and 36' on lower surface 16'. Openings 25, 36 as well as 35' and 36'
17 contain fastener openings through which screws extending from endplates of an artificial disc
18 or the like can be secured, fastening the disc endplate tightly to the vertebral body. The keels
19 of the artificial disc endplate fit into the openings so as to align the screw conduits.

20 **[0033]** Figure 1(c) and 1(d) demonstrate adjacent or integrating surfaces of disc endplate
21 (see Figure 1(c)) with artificial vertebral body (see Figure 1(d)). Keels 70 provided on the
22 artificial disc endplate insert into slots 35 and 36 (or 35' and 36') of the vertebral body.
23 Screw holes allow screws to be inserted, attaching the endplates 22a and 22b to the artificial
24 vertebral body in multilevel disc and body reconstruction. Screw receptacles 23 are shown in
25 the artificial vertebral body diagrams as well as on the keels 70 of the artificial disc. Figure
26 1(c) is a diagram of the surface of the artificial disc endplate that "flips" over and integrates
27 with the vertebral body shown in 1(d). The keels 70 of the disc endplate fit into troughs 35,
28 35', 36, and 36' of the artificial vertebral body. In one embodiment, screws fix superior
29 endplate 22b to inferior surface 16' of the vertebral body, and the inferior endplate 22a of the
30 disc to superior surface 16 of the vertebral body. The screws are inserted from the inside
31 surface of the disc endplates – i.e. the disc must be disassembled to attach the endplates to the
32 artificial vertebral body,

1 **[0034]** As shown in Figures 1(a) and (d) as well as Figure 3, there are provided two sets
2 of stabilizing fins 40 and 40' located on each lateral surface of portions 12 and 14 of the
3 vertebral body. Fins 40 and 40' move from a recessed position to an extended position by
4 means of fin set screws, such as fin set screw 41 as shown in Figure 1(g). Insertion of
5 vertebral body 10 into the surgical vertebrectomy defect occurs with fins 40 and 40' in a
6 recessed position. Once the vertebral body 10 is inserted in the correct position, fin set
7 screws, such as fin set screw 41 can be tightened causing individual fins of fin sets 40 and
8 40'to push out from their recessed position in artificial vertebral body 10 engaging
9 surrounding bone and securing vertebrae 10 in place against the remaining native bone inside
10 the patient.

11 **[0035]** The individual fins of fin sets 40 and 40' are designed to act against vertebral
12 body extrusion. They are tapered toward their posterior aspect and that of the artificial
13 vertebral body but angled perpendicular to the body along their anterior surface. They act in
14 opposition to the overhang of the curved front surface of the artificial vertebral body, which
15 prevents posterior migration.

16 **[0036]** As shown in Figure 3, porous reservoirs 45' and 46' of portion 12', as well as 45
17 and 46 of portion 12 (not shown) are located behind curved surface 20 or 20' along lateral
18 surfaces 19 and 21 as well as 19' and 21'of portions 12 and 12' respectively. Reservoirs 45,
19 46, 45' and 46' act as hollow cages with small perforations in their outside walls. The cages
20 are open at their upper and lower ends to allow for insertion of a substance to promote the
21 growth of bone. The porous reservoirs contain this bone growth substance helping to release
22 it locally in a controlled fashion encouraging bone to actively grow into the perforations and
23 stabilize the artificial vertebral body against normal bone inside the spine of the recipient
24 patient. The porous reservoirs can rest adjacent to similar reservoirs located in the artificial
25 disc endplate. It will be understood that the exterior surfaces of the artificial vertebral body
26 10 or 10' may also include various physical features such as a porous or pitted surface, a
27 plurality of pins, ribs etc. that promote bony in-growth so as to anchor the prosthesis in place
28 in the spine. Various other such anchoring means will be known to persons skilled in the art.

29 **[0037]** In another embodiment, sets of stabilizing fins 40 and 40' and/or reservoirs 45, 46,
30 45' and 46' in one portion of the vertebral body 10 might be partially or completely
31 substituted for a depression or indentations, as shown in Figures 4, 5 and 6. These

1 depressions serve as insertion points for artificial pedicles that are adapted to be received
2 within the depressions. The pedicle is the part of each side of the neural arch of a vertebra. It
3 connects the lamina with the vertebral body. In one embodiment of the present invention, the
4 artificial pedicle might be hollow to allow a drill to be positioned inside of it, and used to drill
5 through the depression into the body of the artificial vertebrae. A screw might then be
6 inserted through the pedicle tightening into the artificial vertebral body and securing the
7 pedicle against the artificial vertebral body. As shown in Figure 6 (a), there is provided
8 pedicle fastener 60 in artificial pedicle 61, which rests in depression or aperture 65 of
9 vertebral body 70 (see also Figure 6(b) and (c)). As can also be seen in Figure 6(a) a drill bit
10 61 advances into a lateral surface of vertebral 70.

11 **[0038]** In yet a further embodiment, as shown in Figure 5, the aperture or depression
12 might extend farther into a portion of the vertebral body forming a pedicle fastener receptacle
13 or sleeve that doesn't require drilled as shown in Figure 6. As shown in Figure 5(a), (b) and
14 (c), receptacle 80 is angled tangential to the side of vertebral body 85 to generally cross from
15 one lateral surface towards the anterior surface or towards the midline of the front of the
16 artificial vertebral body. Receptacle 80 may have threads in its walls to receive a threaded
17 fastener of appropriate dimensions. The receptacle or pedicle screw sleeve can be embodied
18 by a hollowed-out portion of the vertebral body or may be fashioned as a separate
19 component, assembled into the artificial vertebral body as shown in Figure 5.

20 **[0039]** As shown in Figures 4 (a) to (d), a receptacle or pedicle screw sleeve 100 can be
21 fashioned as a separate component and assembled into the artificial vertebral body. Posts 102
22 and 104 arising from the upper and lower surfaces of the sleeve can act as a hinge recessed
23 inside the artificial vertebral body (as shown in Figure 1(d)) so that the pedicle sleeve 100 can
24 rotate about post. This allows the pedicle screw sleeve 100 to accommodate pedicle screws
25 from different angles (as shown in Figure 1(d)). The outer end of the pedicle screw
26 receptacle is expanded so that an artificial pedicle can be inserted into it, locking it in place
27 with respect to the receptacle and the artificial vertebral body.

28 **[0040]** The posts arising from the upper and lower surfaces of the pedicle screw
29 receptacle can be embedded in recessed grooves running front to back in the artificial
30 vertebral body. The grooves provide a track along which the pedicle sleeve can move

1 forwards or backwards in relation to the artificial vertebral body while maintaining angular
2 motion about the posts.

3 **[0041]** The grooves can be angled inwards or outwards (front to back) to prevent
4 forwards or backwards migration of the artificial pedicles once they have been secured to the
5 artificial vertebral body. It is envisioned that the artificial pedicles will be directly or
6 indirectly connected to each other from behind in addition to their connection to the artificial
7 vertebral body. The additional connection prevents the artificial pedicles from sliding along
8 their posts inside grooves on either side of the vertebral body that point in opposing
9 directions.

10 **[0042]** Additionally, a separate rectangular compartment built into the wall of the
11 artificial vertebral body may house the grooves containing the pedicle screw sleeve. This
12 rectangular housing could be connected to the artificial vertebral body by two side rails
13 protruding into it at each end. The side rails (tongue in groove) prevent the housing from
14 extruding outside or inside of the artificial vertebral body but allow the housing to move
15 upwards and downwards within the wall of the artificial vertebral body. This is illustrated in
16 Figures 4b and 4d.

17 **[0043]** The side rails can be angled in towards the middle of the artificial body or out
18 towards the sides (from the top downwards) to prevent the rectangular compartment from
19 moving once the artificial pedicles have been secured to the artificial vertebral body. It is
20 envisioned that the artificial pedicles will be directly or indirectly connected to each other
21 from behind in addition to their connection to the artificial vertebral body. The additional
22 connection prevents the artificial pedicles and their respective rectangular housings from
23 sliding up or down on rails that point in opposing directions on either side of the artificial
24 vertebral body.

25 **[0044]** The artificial vertebral body can be used with artificial discs to reconstruct
26 multiple levels in the spinal column. It can be manufactured in a variety of widths, heights,
27 and depths.

28 **[0045]** Although the invention has been described with reference to certain specific
29 embodiments, various modifications thereof will be apparent to those skilled in the art

1 without departing from the purpose and scope of the invention as outlined herein. The entire
2 disclosures of all references recited above are incorporated herein by reference.

3

WE CLAIM:

1. An artificial vertebral body comprising:
 - a superior portion and an inferior portion, each of said superior and inferior portions having superior and inferior surfaces and lateral sides;
 - the superior surface of said inferior portion being in contact and in positive engagement with the inferior surface of said superior portion;
 - the superior surface of said superior portion and the inferior surface of said inferior portion having one or more engagement means to engage adjacent spinal structures.
2. The vertebral body of claim 1 wherein said positive engagement is provided by one or more engagement means.
3. The vertebral body of claim 2 wherein said engagement means comprises the superior surface of said inferior portion and the inferior surface of said superior portion having cooperatively toothed surfaces.
4. The vertebral body of claim 3 wherein said engagement means further comprises one or more screws extending from one of said portions to the other of said portions.
5. The vertebral body of claim 4 wherein the relative position of the superior and inferior portions about the sagittal plane may be varied by releasing and re-engaging the engagement means.
6. The vertebral body of claim 5 wherein the anterior surface of said body is convexly curved about the coronal plane.
7. The vertebral body of claim 6 wherein the posterior surface of said body is generally flat.
8. The vertebral body of claim 7 wherein at least one of the superior surface of said superior portion or the inferior surface of said inferior portion includes a means to engage an adjacent artificial surface.

9. The vertebral body according to any one of claims 1 to 8 wherein said body includes outwardly extending fins to engage adjacent bony structures.
10. The vertebral body of claim 9 wherein said fins are extendable.
11. The vertebral body of claim 10 wherein said body includes one or more adjustment screws to extend said fins.
12. The vertebral body of claim 11 wherein said fins are provided on lateral sides of said body.
13. The vertebral body of claim 12 wherein one or more external surfaces of said body include one or more physical and/or chemical bone growth promoters.
14. The vertebral body of claim 13 wherein said one or more external surfaces includes a reservoir for holding and releasing one or more bone growth promoting compounds.

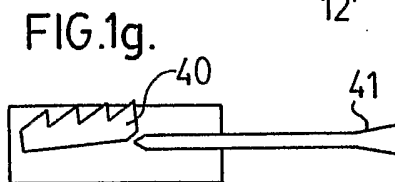
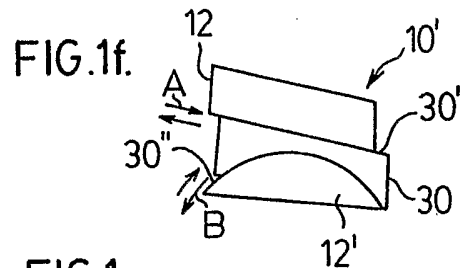
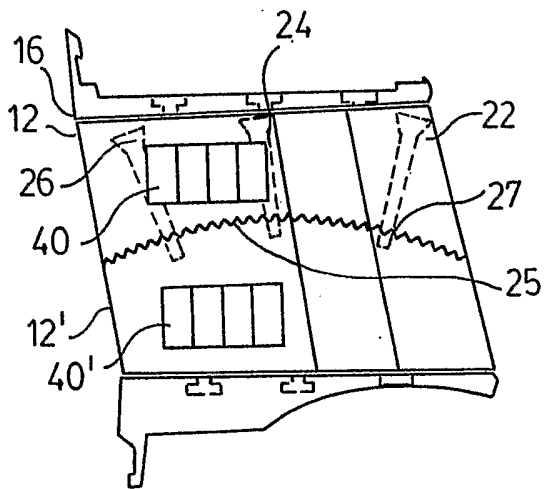
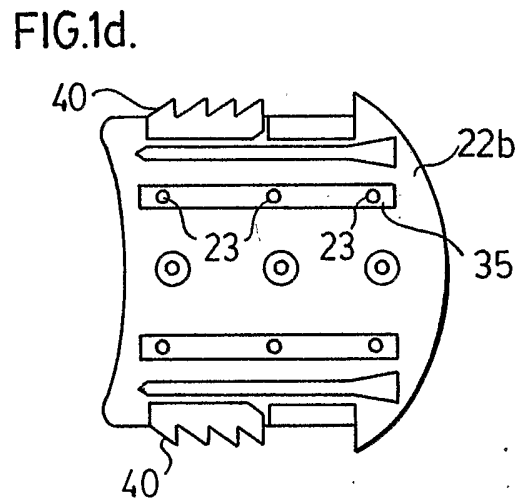
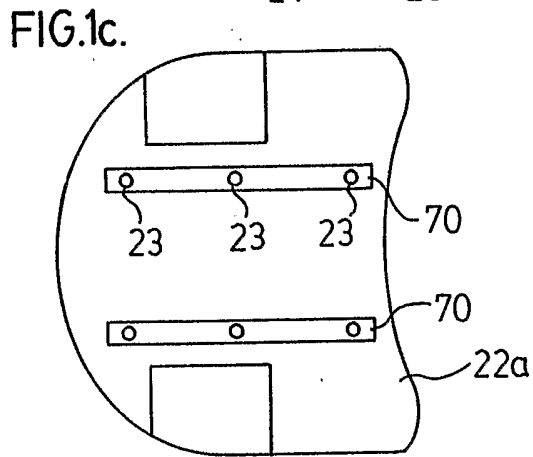
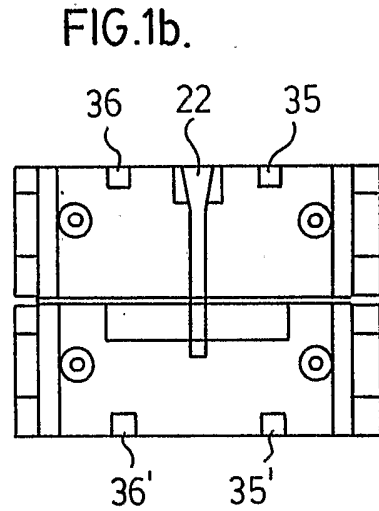
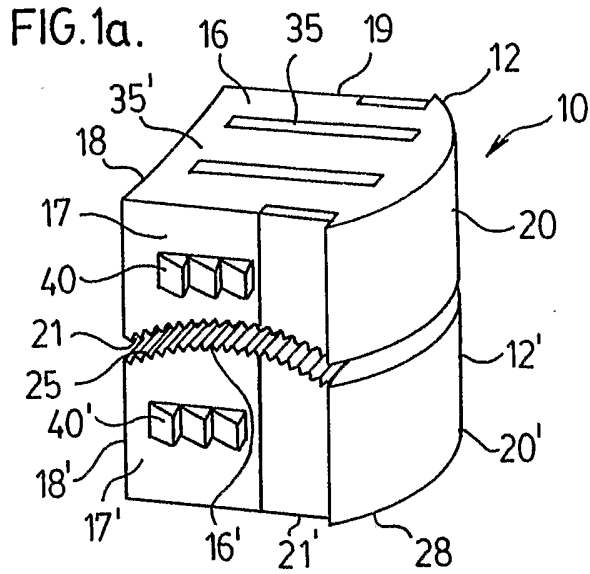

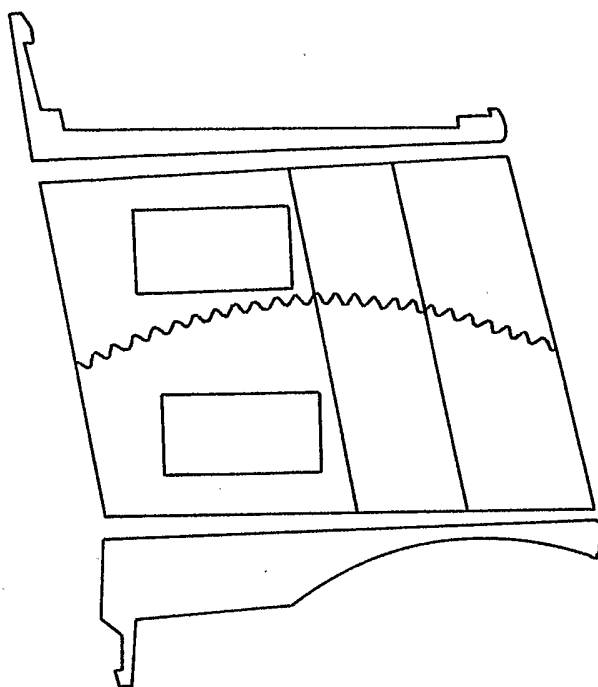

FIG. 2.

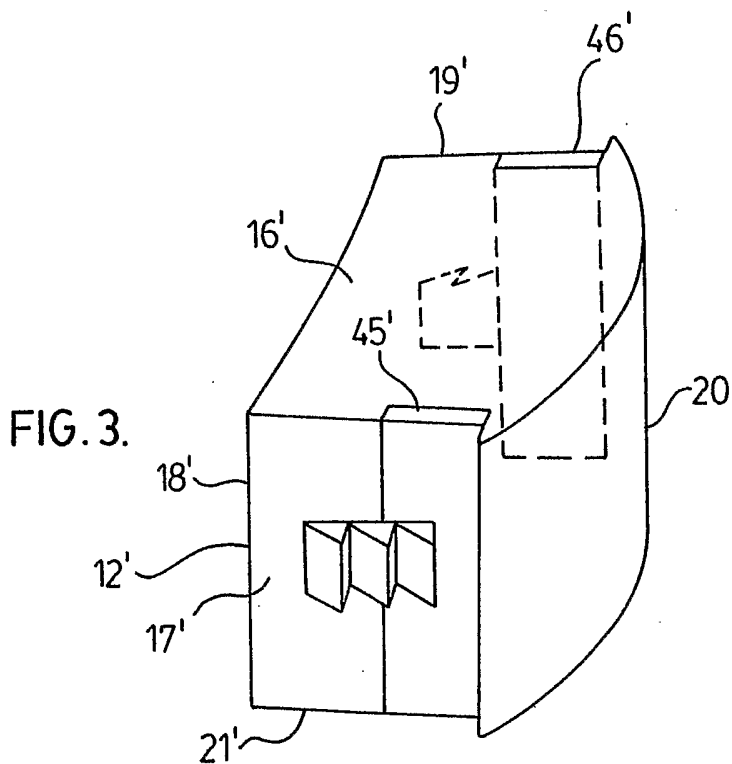

FIG. 3.

3/11

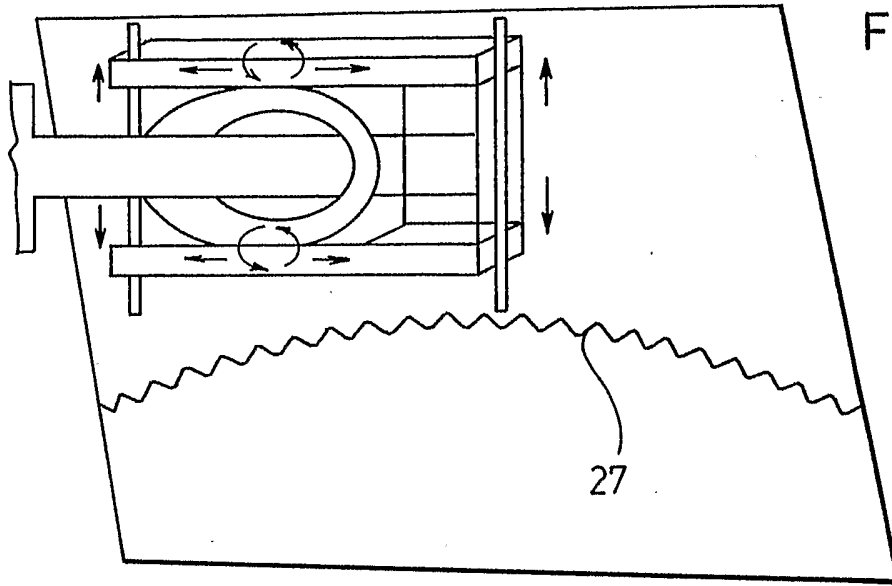

FIG. 4a.

FIG. 4b.

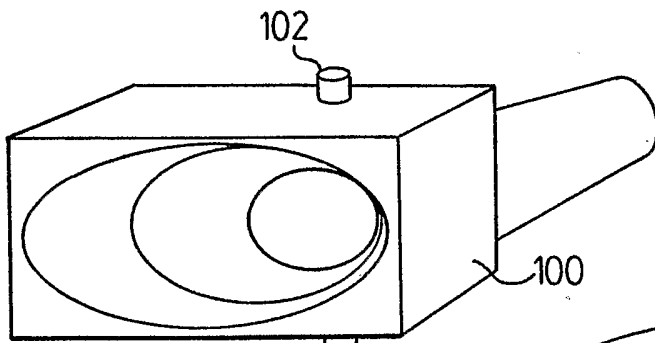
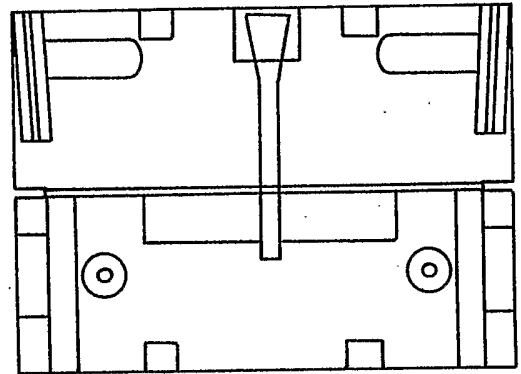
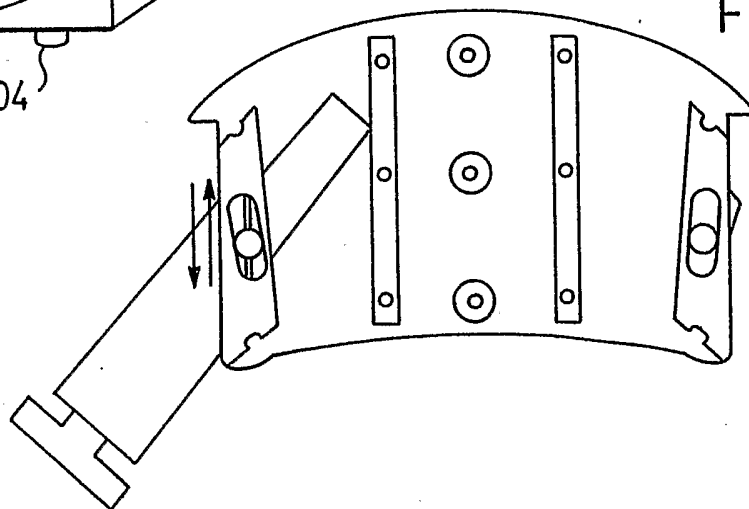

FIG. 4c.

FIG. 4d.



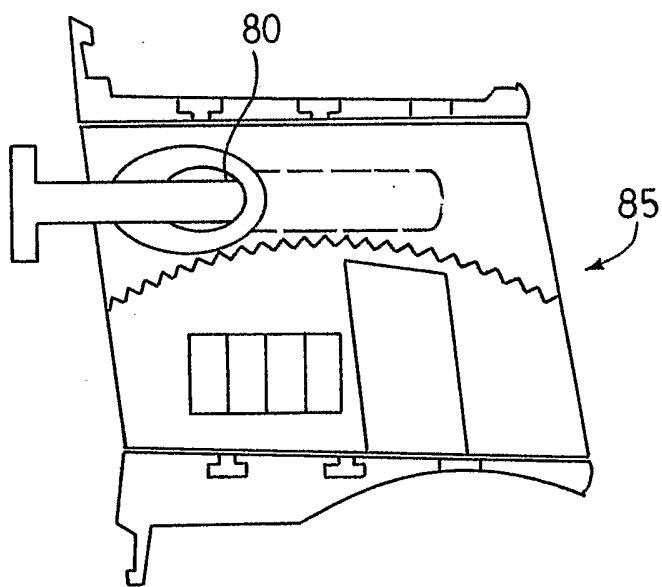
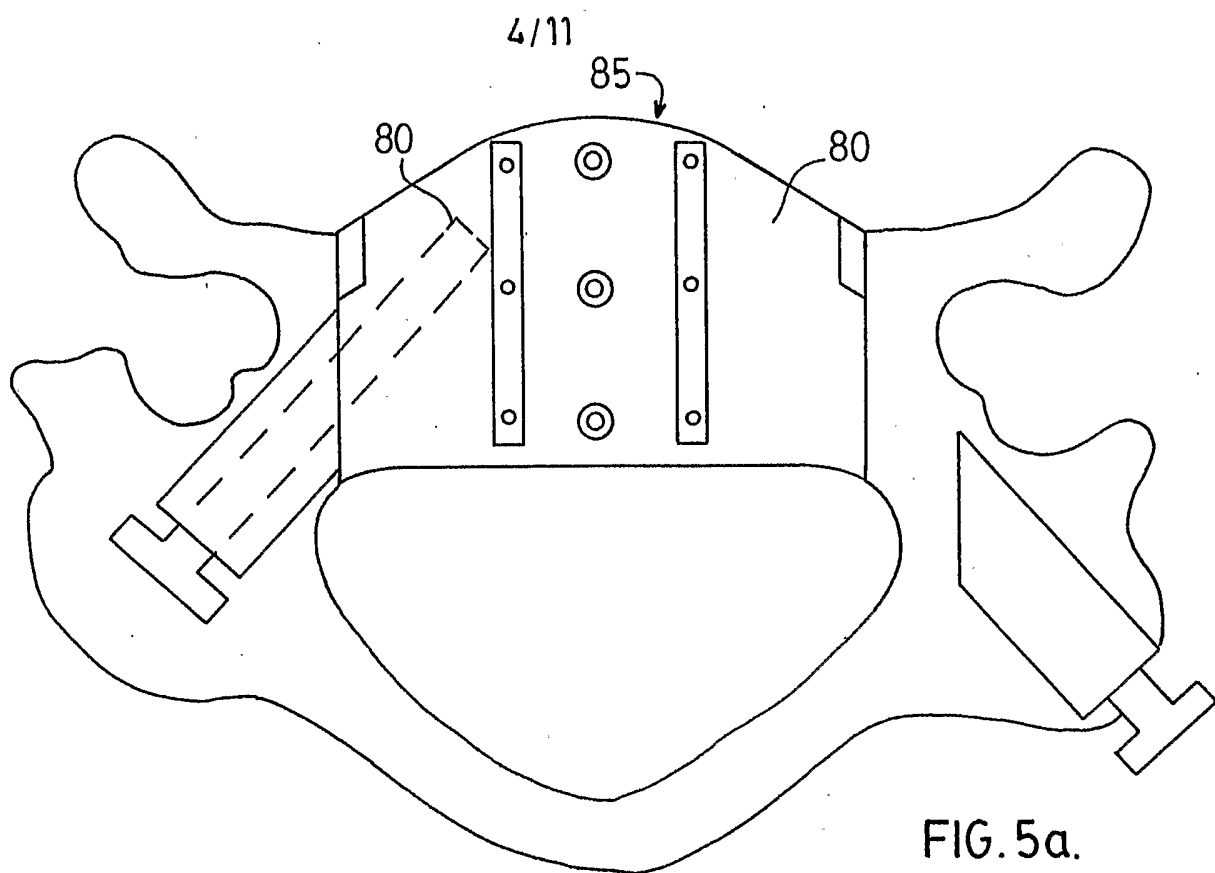

FIG. 5b.

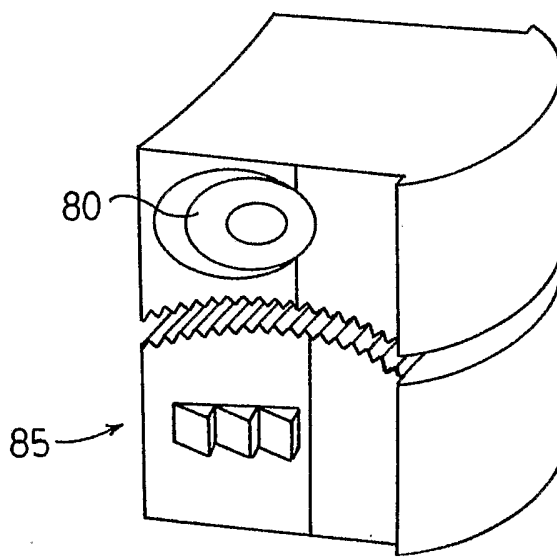

FIG. 5c.

5/11

FIG. 6a.

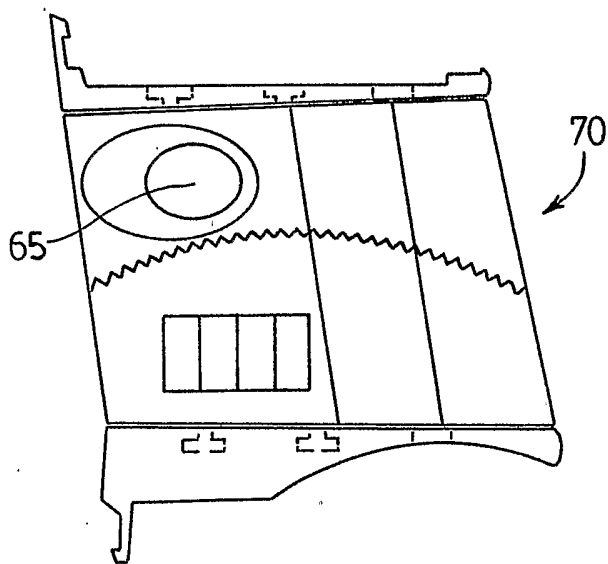
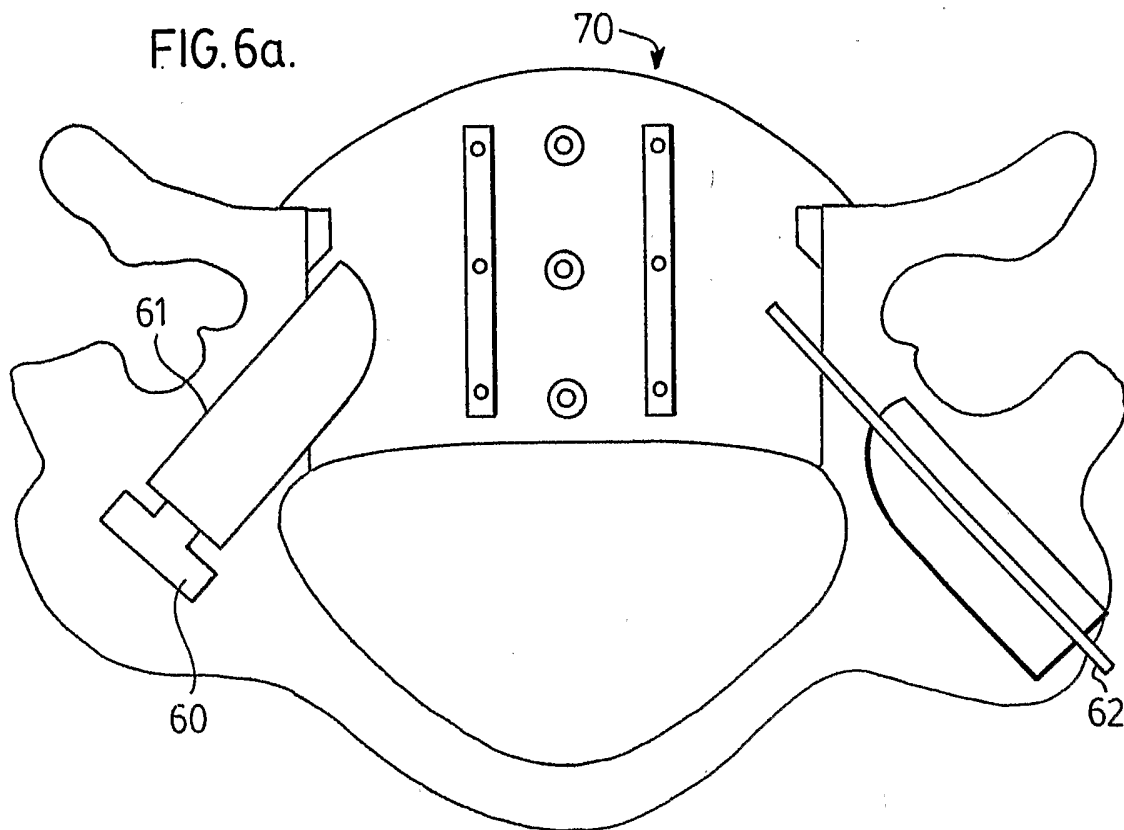
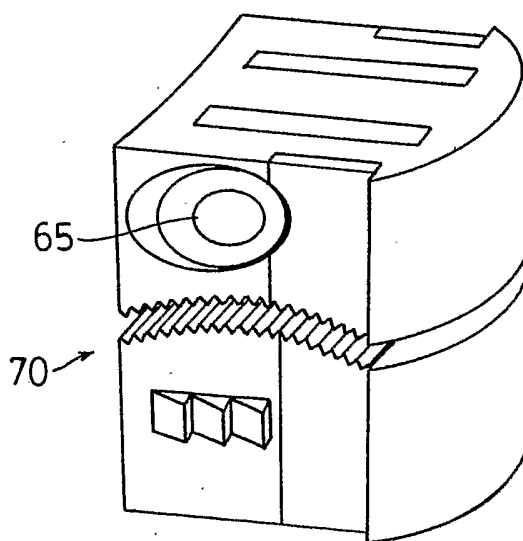

FIG. 6b.

FIG. 6c.



6/11

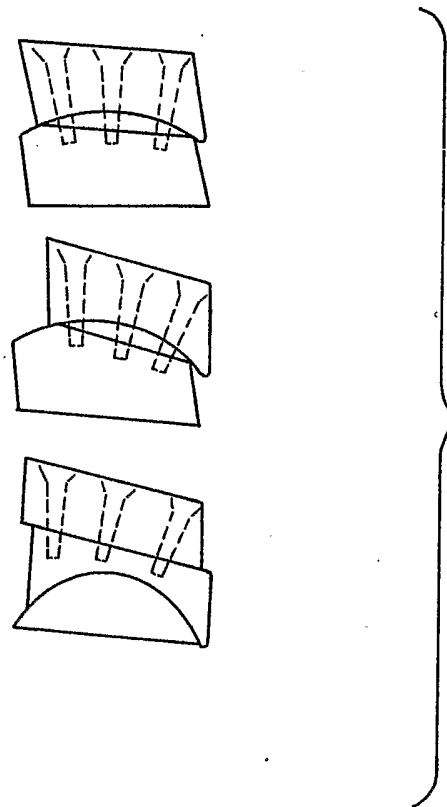
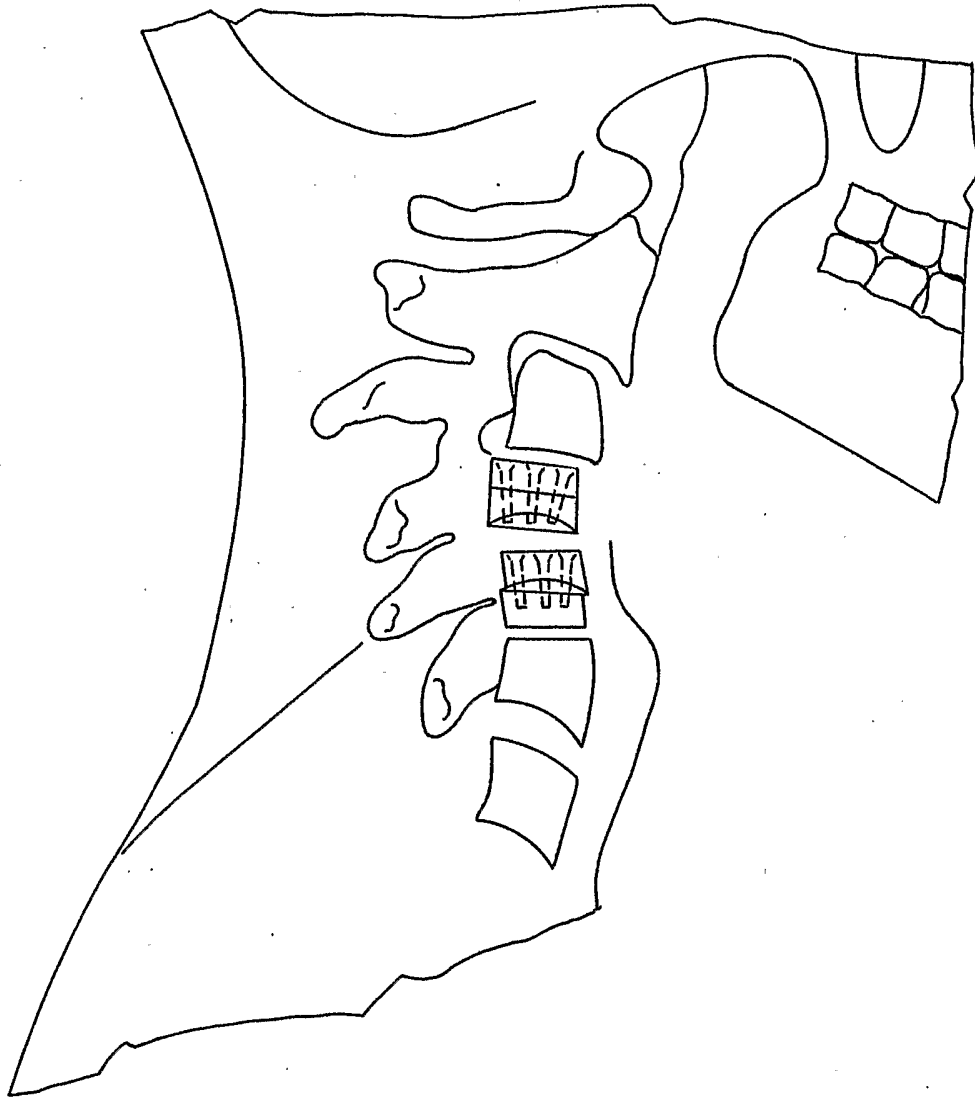

FIG. 7.

7/11

FIG. 7a.



8/11

FIG. 7b.

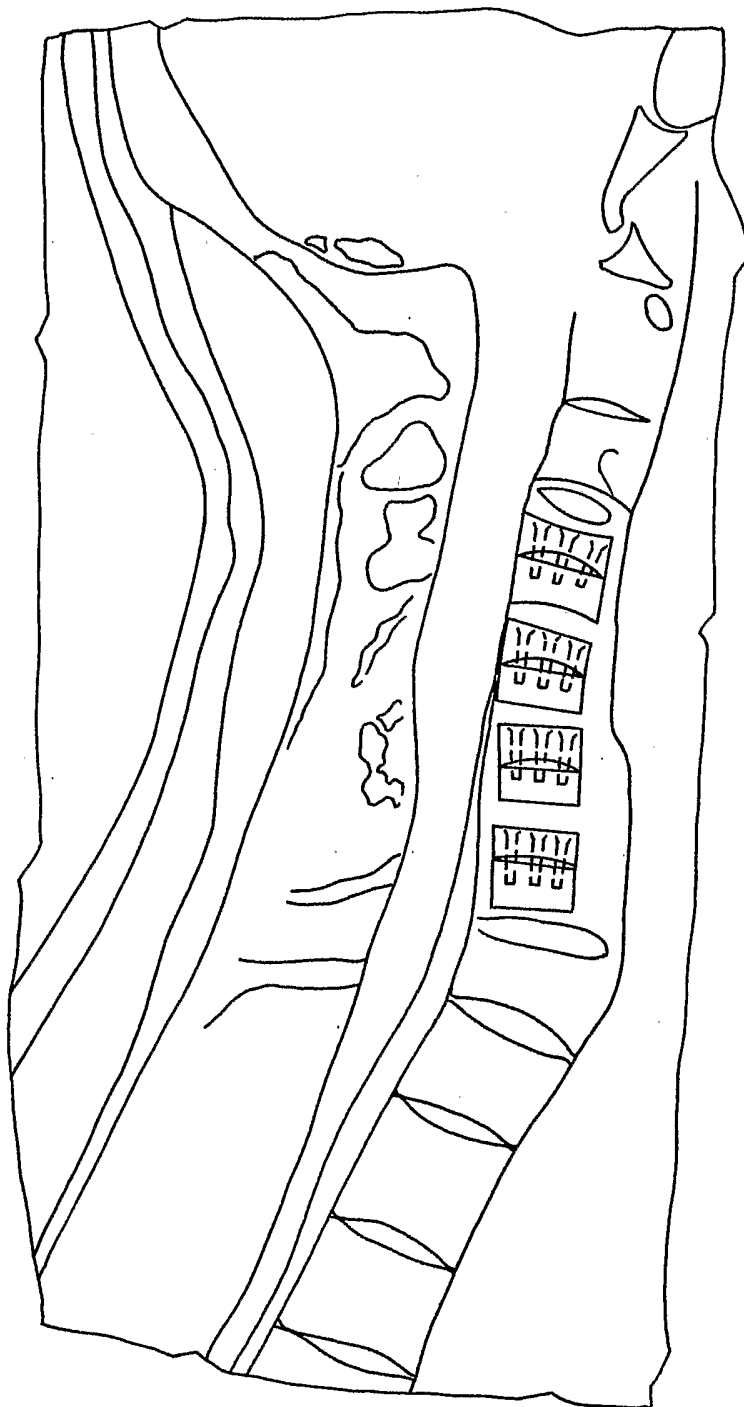

9/11

FIG. 8.

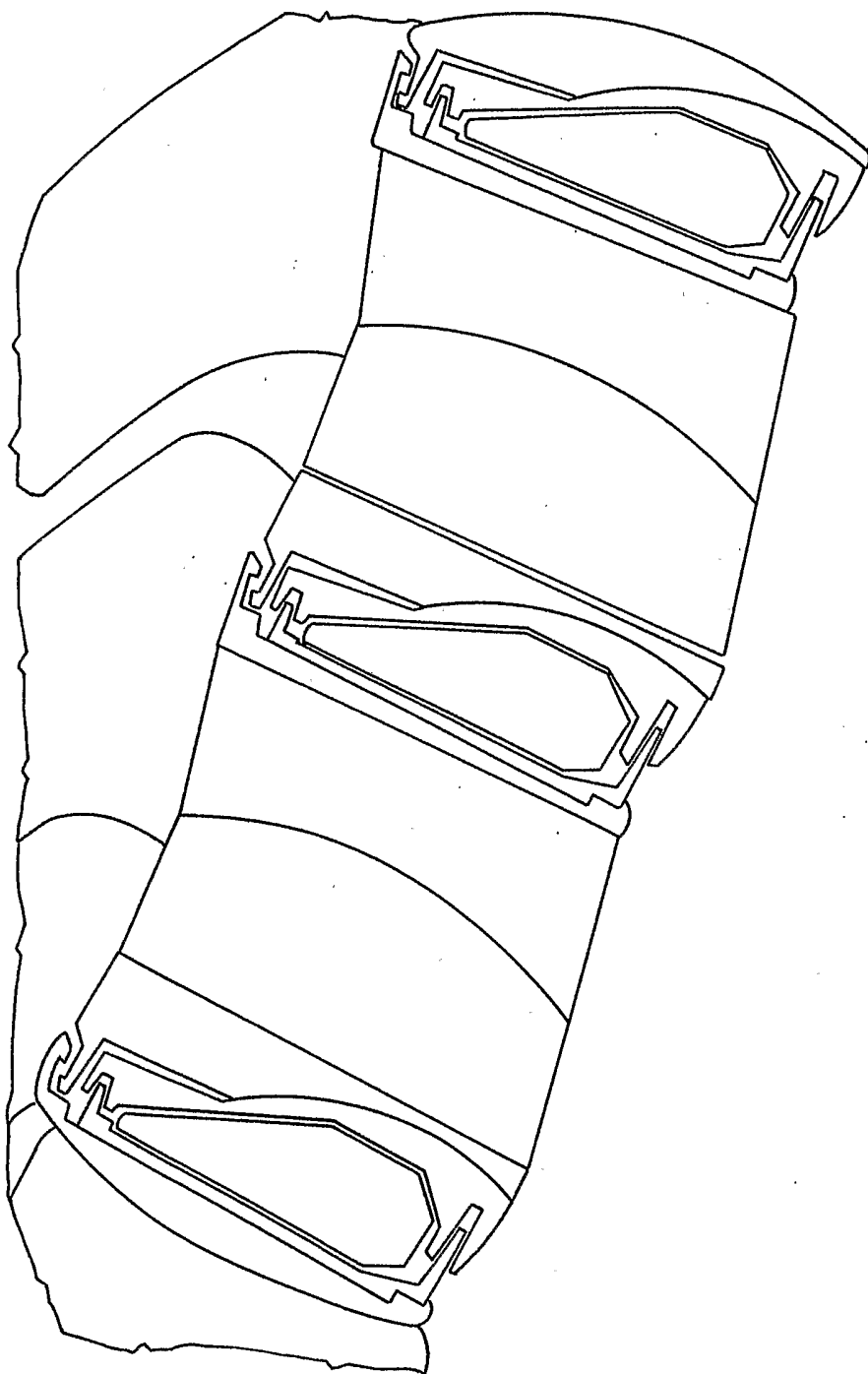

FIG. 8a.

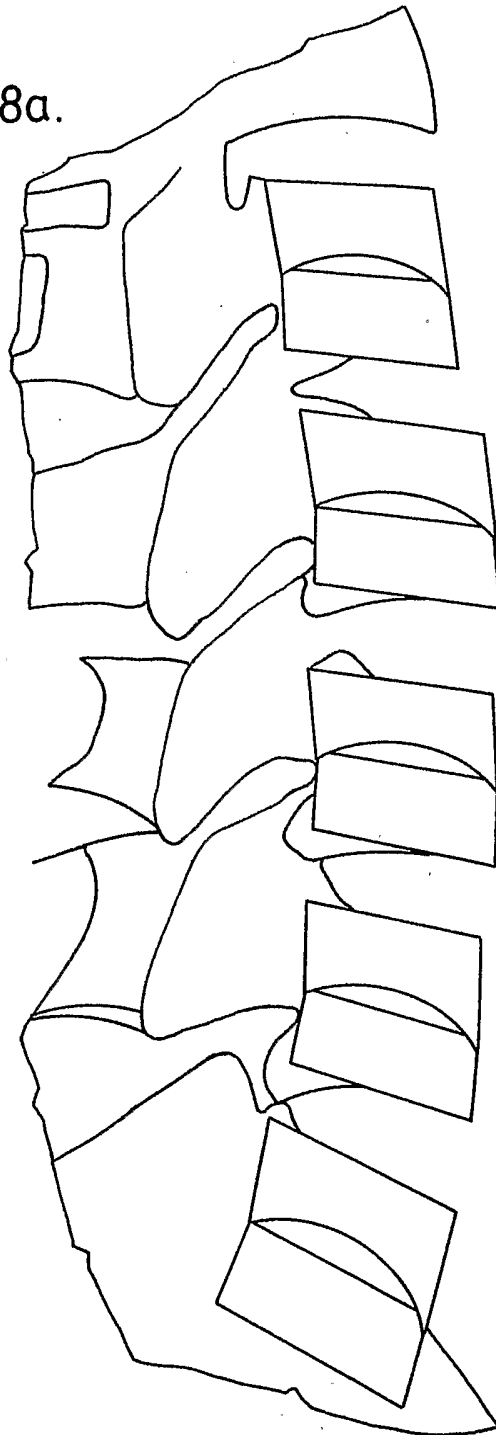
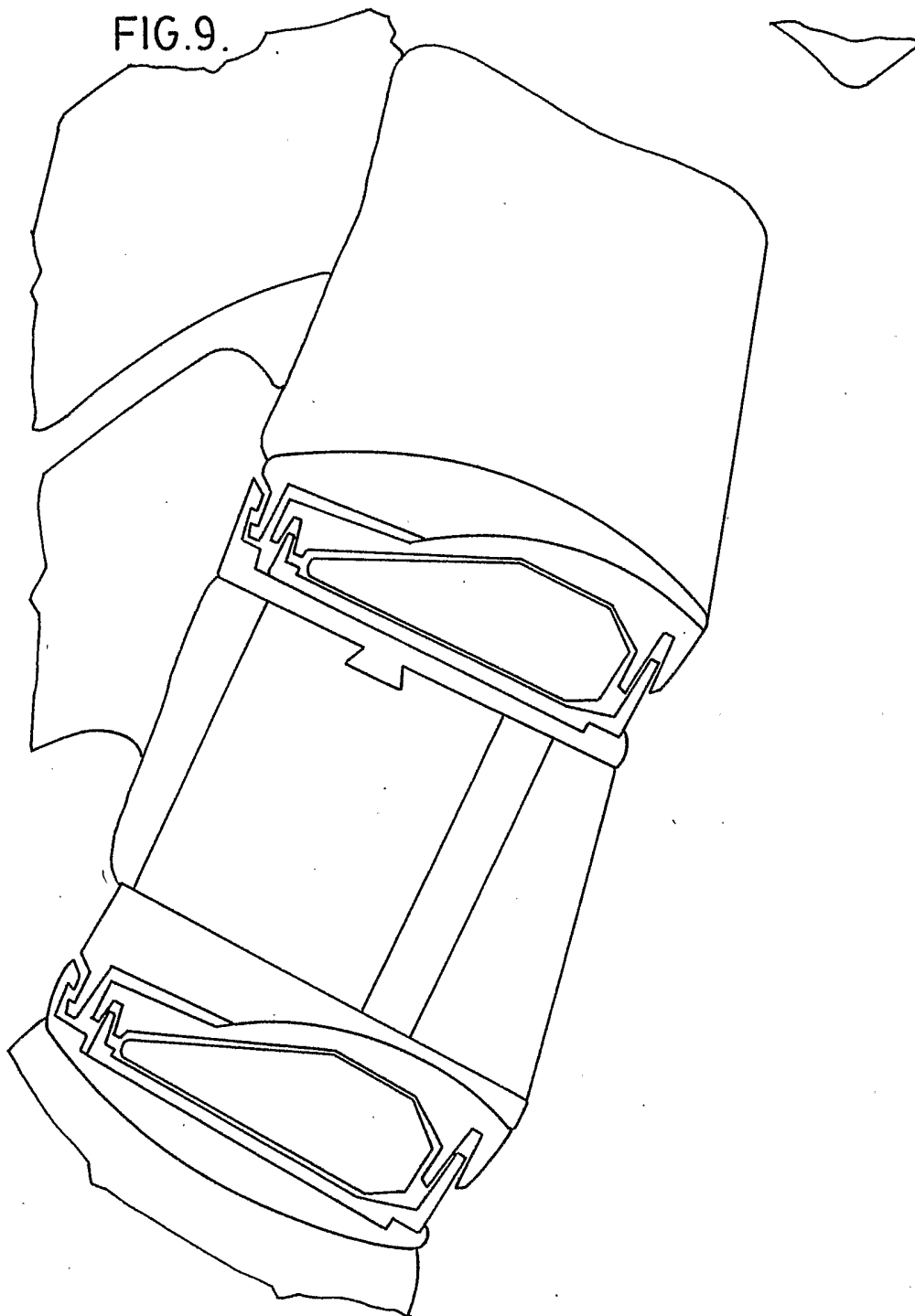

FIG. 9.



INTERNATIONAL SEARCH REPORT

International application No.
PCT/CA2006/000675

A. CLASSIFICATION OF SUBJECT MATTER
IPC: **A61F 2/44** (2006.01)
According to International Patent Classification (IPC) or to both national classification and IPC

B. FIELDS SEARCHED

Minimum documentation searched (classification system followed by classification symbols)
IPC (2006.01) : A61F-2/44, and A61F-all
US Classification: 623/17, 17.11 to 17.15

Documentation searched other than minimum documentation to the extent that such documents are included in the fields searched

Electronic database(s) consulted during the international search (name of database(s) and, where practicable, search terms used)
Delphion & Canadian patent database: A61F-2/44, 623/17, spinal, vertebral, implant, prosthesis, translation, locking

C. DOCUMENTS CONSIDERED TO BE RELEVANT

Category*	Citation of document, with indication, where appropriate, of the relevant passages	Relevant to claim No.
X Y	CA 2520205 (Lange et al.) 04-Nov-2004 (04-11-2004) Entire document, Figures 24-26	1-4 6-14
X Y	US 5865848 (Baker) 02-Feb-1999 (02-02-1999) Entire document	1-5 6-14
Y	US 6723126 (Berry) 20-April-2004 (20-04-2004) Entire document	10-14
Y, P	US 2006/0095136 (McLuen) 04-May-2006 (04-05-2006) Figures 1-2	10-14
A	US 6025538 (Yaccarino) 15-Feb-2000 (15-02-2000) Entire document	1-14
A	US 5571190 (Ulrich et al.) 05-Nov-1996 (05-11-1996) Entire document	1-14

Further documents are listed in the continuation of Box C. See patent family annex.

* Special categories of cited documents :	"T" later document published after the international filing date or priority date and not in conflict with the application but cited to understand the principle or theory underlying the invention
"A" document defining the general state of the art which is not considered to be of particular relevance	"X" document of particular relevance; the claimed invention cannot be considered novel or cannot be considered to involve an inventive step when the document is taken alone
"E" earlier application or patent but published on or after the international filing date	"Y" document of particular relevance; the claimed invention cannot be considered to involve an inventive step when the document is combined with one or more other such documents, such combination being obvious to a person skilled in the art
"L" document which may throw doubts on priority claim(s) or which is cited to establish the publication date of another citation or other special reason (as specified)	"&" document member of the same patent family
"O" document referring to an oral disclosure, use, exhibition or other means	
"P" document published prior to the international filing date but later than the priority date claimed	

Date of the actual completion of the international search 03 July 2006 (03-07-2006)	Date of mailing of the international search report 29 August 2006 (29-08-2006)
--	---

Name and mailing address of the ISA/CA Canadian Intellectual Property Office Place du Portage I, C114 - 1st Floor, Box PCT 50 Victoria Street Gatineau, Quebec K1A 0C9 Facsimile No.: 001(819)953-2476	Authorized officer Hoan Huynh (819) 934-3467
---	---

INTERNATIONAL SEARCH REPORT
Information on patent family members

International application No.
PCT/CA2006/000675

Patent Document Cited in Search Report	Publication Date	Patent Family Member(s)	Publication Date
CA2520205	04-11-2004	AU2003218315 A1	08-10-2003
		AU2004231483 A1	04-11-2004
		CA2479802 A1	02-10-2003
		EP1490003 A1	29-12-2004
		EP1610732 A2	04-01-2006
		JP2005520629T T	14-07-2005
		US6758862 B2	06-07-2004
		US6991653 B2	31-01-2006
		US2003191531 A1	09-10-2003
		US2004236427 A1	25-11-2004
		WO03079939 A1	02-10-2003
WO2004093751 A2	04-11-2004		
US5865848	02-02-1999	AU744151 B2	14-02-2002
		AU9226998 A	05-04-1999
		CA2303181 A1	25-03-1999
		EP1011546 A1	28-06-2000
		WO9913806 A1	25-03-1999
US6723126	20-04-2004	AU2003286706 A1	07-06-2004
		CA2504584 A1	21-05-2004
		EP1567096 A1	31-08-2005
		JP2006504485T T	09-02-2006
		US6953477 B2	11-10-2005
		WO2004041130 A1	21-05-2004
US2006095136	04-05-2006	WO2006050500 A2	11-05-2006
US6025538	15-02-2000	AU733499 B2	17-05-2001
		AU1713000 A	13-06-2000
		CA2289990 A1	20-05-2000
		EP1049428 A1	08-11-2000
		US7044968 B1	16-05-2006
		WO0030568 A1	02-06-2000
US5571190	05-11-1996	DE4328062 A1	23-02-1995
		DE59408785D D1	04-11-1999
		EP0639351 A2	22-02-1995
		JP7148190 A	13-06-1995