

(19) World Intellectual Property  
Organization  
International Bureau



(43) International Publication Date  
29 December 2004 (29.12.2004)

PCT

(10) International Publication Number  
**WO 2004/113496 A2**

- (51) International Patent Classification<sup>7</sup>: **C12N**
- (21) International Application Number: PCT/US2004/017487
- (22) International Filing Date: 3 June 2004 (03.06.2004)
- (25) Filing Language: English
- (26) Publication Language: English
- (30) Priority Data:
- |            |                                |    |
|------------|--------------------------------|----|
| 60/480,048 | 20 June 2003 (20.06.2003)      | US |
| 60/507,250 | 29 September 2003 (29.09.2003) | US |
| 60/531,566 | 19 December 2003 (19.12.2003)  | US |
| 60/568,140 | 4 May 2004 (04.05.2004)        | US |
- (71) Applicant (for all designated States except US): **ISIS PHARMACEUTICALS, INC.** [US/US]; 2292 Faraday Avenue, Carlsbad, CA 92008 (US).
- (72) Inventors; and
- (75) Inventors/Applicants (for US only): **KRAYNACK, Brian, A.** [US/US]; 4615 Pico Street #2, San Diego, CA 92109 (US). **BAKER, Brenda, F.** [US/US]; 2927 Rancho Cortes, Carlsbad, CA 92009 (US). **BHAT, Balkrishen** [IN/US]; 911 Rosemary Avenue, Carlsbad, CA 92009 (US). **SWAYZE, Eric** [US/US]; 7789 Palenque Street, Carlsbad, CA 92009 (US). **GRIFFEY, Richard, H.** [US/US]; 360 Barsby Street, Vista, CA 92084 (US).
- (74) Agent: **STRAHER, Michael, P.**; Cozen O'Connor, 1900 Market Street, Philadelphia, PA 19103 (US).
- (81) Designated States (unless otherwise indicated, for every kind of national protection available): AE, AG, AL, AM, AT, AU, AZ, BA, BB, BG, BR, BW, BY, BZ, CA, CH, CN, CO, CR, CU, CZ, DE, DK, DM, DZ, EC, EE, EG, ES, FI, GB, GD, GE, GH, GM, HR, HU, ID, IL, IN, IS, JP, KE, KG, KP, KR, KZ, LC, LK, LR, LS, LT, LU, LV, MA, MD, MG, MK, MN, MW, MX, MZ, NA, NI, NO, NZ, OM, PG, PH, PL, PT, RO, RU, SC, SD, SE, SG, SK, SL, SY, TJ, TM, TN, TR, TT, TZ, UA, UG, US, UZ, VC, VN, YU, ZA, ZM, ZW.
- (84) Designated States (unless otherwise indicated, for every kind of regional protection available): ARIPO (BW, GH, GM, KE, LS, MW, MZ, NA, SD, SL, SZ, TZ, UG, ZM, ZW), Eurasian (AM, AZ, BY, KG, KZ, MD, RU, TJ, TM), European (AT, BE, BG, CH, CY, CZ, DE, DK, EE, ES, FI, FR, GB, GR, HU, IE, IT, LU, MC, NL, PL, PT, RO, SE, SI, SK, TR), OAPI (BF, BJ, CF, CG, CI, CM, GA, GN, GQ, GW, ML, MR, NE, SN, TD, TG).

**Published:**

— without international search report and to be republished upon receipt of that report

For two-letter codes and other abbreviations, refer to the "Guidance Notes on Codes and Abbreviations" appearing at the beginning of each regular issue of the PCT Gazette.

(54) Title: DOUBLE STRANDED COMPOSITIONS COMPRISING A 3'-ENDO MODIFIED STRAND FOR USE IN GENE MODULATION

(57) Abstract: The present invention provides double stranded compositions that have a region that is complementary to a target nucleic acid. One of the targeting strand or the second strand comprises linked ribofuranosyl nucleosides and the other strand comprises linked modified nucleosides that have 3'-endo conformational geometry. The strands can be linked together or separate and may contain additional groups. The present invention also provides methods of using the compositions for modulating gene expression.

WO 2004/113496 A2

**DOUBLE STRANDED COMPOSITIONS COMPRISING A 3'-ENDO  
MODIFIED STRAND FOR USE IN GENE MODULATION**

5

**Cross Reference to Related Applications**

The present application claims benefit to U.S. Provisional Application Serial Number 60/568,140 filed May 4, 2004, U.S. Provisional Application Serial Number 60/531,566 filed December 19, 2003 and U.S. Provisional Application Serial Number  
10 60/507,250 filed September 29, 2003, which are incorporated herein by reference in their entirety.

**Field of the Invention**

The present invention provides compositions comprising a first oligomeric  
15 compound and a second oligomeric compound that hybridize with each other and wherein the first oligomeric compound has complementarity to and hybridizes to a target nucleic acid and methods for their use in modulating gene expression. In preferred embodiments oligomeric compounds of compositions of the present invention hybridize to a portion of a target RNA resulting in loss of normal function of the target RNA.

20

**Background of the Invention**

In many species, introduction of double-stranded RNA (dsRNA) induces potent and specific gene silencing. This phenomenon occurs in both plants and animals and has roles in viral defense and transposon silencing mechanisms. This phenomenon was  
25 originally described more than a decade ago by researchers working with the petunia flower. While trying to deepen the purple color of these flowers, Jorgensen et al. introduced a pigment-producing gene under the control of a powerful promoter. Instead of the expected deep purple color, many of the flowers appeared variegated or even white. Jorgensen named the observed phenomenon "cosuppression", since the expression  
30 of both the introduced gene and the homologous endogenous gene was suppressed (Napoli et al., *Plant Cell*, 1990, 2, 279-289; Jorgensen et al., *Plant Mol. Biol.*, 1996, 31, 957-973).

Cosuppression has since been found to occur in many species of plants, fungi, and has been particularly well characterized in *Neurospora crassa*, where it is known as

"quelling" (Cogoni and Macino, *Genes Dev.* **2000**, 10, 638-643; Guru, *Nature*, **2000**, 404, 804-808).

5 The first evidence that dsRNA could lead to gene silencing in animals came from work in the nematode, *Caenorhabditis elegans*. In 1995, researchers Guo and Kempheus were attempting to use antisense RNA to shut down expression of the par-1 gene in order to assess its function. As expected, injection of the antisense RNA disrupted expression of par-1, but quizzically, injection of the sense-strand control also disrupted expression (Guo and Kempheus, *Cell*, **1995**, 81, 611-620). This result was a puzzle until Fire et al. injected dsRNA (a mixture of both sense and antisense strands) into *C. elegans*. This injection resulted in much more efficient silencing than injection of either the sense or the antisense strands alone. Injection of just a few molecules of dsRNA per cell was sufficient to completely silence the homologous gene's expression. Furthermore, injection of dsRNA into the gut of the worm caused gene silencing not only throughout the worm, but also in first generation offspring (Fire et al., *Nature*, **1998**, 391, 806-811).

15 The potency of this phenomenon led Timmons and Fire to explore the limits of the dsRNA effects by feeding nematodes bacteria that had been engineered to express dsRNA homologous to the *C. elegans* unc-22 gene. Surprisingly, these worms developed an unc-22 null-like phenotype (Timmons and Fire, *Nature* **1998**, 395, 854; Timmons et al., *Gene*, **2001**, 263, 103-112). Further work showed that soaking worms in dsRNA was also able to induce silencing (Tabara et al., *Science*, **1998**, 282, 430-431). PCT publication WO 01/48183 discloses methods of inhibiting expression of a target gene in a nematode worm involving feeding to the worm a food organism which is capable of producing a double-stranded RNA structure having a nucleotide sequence substantially identical to a portion of the target gene following ingestion of the food organism by the nematode, or by introducing a DNA capable of producing the double-stranded RNA structure (Bogaert et al., 2001).

25 The posttranscriptional gene silencing defined in *C. elegans* resulting from exposure to double-stranded RNA (dsRNA) has since been designated as RNA interference (RNAi). This term has come to generalize all forms of gene silencing involving dsRNA leading to the sequence-specific reduction of endogenous targeted mRNA levels; unlike co-suppression, in which transgenic DNA leads to silencing of both the transgene and the endogenous gene. Introduction of exogenous double-stranded RNA (dsRNA) into *C. elegans* has been shown to specifically and potently disrupt the activity of genes containing homologous sequences. Montgomery et al. suggests that the

primary interference effects of dsRNA are post-transcriptional; this conclusion being derived from examination of the primary DNA sequence after dsRNA-mediated interference a finding of no evidence of alterations followed by studies involving alteration of an upstream operon having no effect on the activity of its downstream gene.

5 These results argue against an effect on initiation or elongation of transcription. Finally they observed by *in situ* hybridization, that dsRNA-mediated interference produced a substantial, although not complete, reduction in accumulation of nascent transcripts in the nucleus, while cytoplasmic accumulation of transcripts was virtually eliminated. These results indicate that the endogenous mRNA is the primary target for interference

10 and suggest a mechanism that degrades the targeted mRNA before translation can occur. It was also found that this mechanism is not dependent on the SMG system, an mRNA surveillance system in *C. elegans* responsible for targeting and destroying aberrant messages. The authors further suggest a model of how dsRNA might function as a catalytic mechanism to target homologous mRNAs for degradation. (Montgomery et al.,

15 *Proc. Natl. Acad. Sci. U S A*, **1998**, *95*, 15502-15507).

Recently, the development of a cell-free system from syncytial blastoderm *Drosophila* embryos that recapitulates many of the features of RNAi has been reported. The interference observed in this reaction is sequence specific, is promoted by dsRNA but not single-stranded RNA, functions by specific mRNA degradation, and requires a

20 minimum length of dsRNA. Furthermore, preincubation of dsRNA potentiates its activity demonstrating that RNAi can be mediated by sequence-specific processes in soluble reactions (Tuschl et al., *Genes Dev.*, **1999**, *13*, 3191-3197).

In subsequent experiments, Tuschl et al., using the *Drosophila in vitro* system, demonstrated that 21- and 22-nt RNA fragments are the sequence-specific mediators of

25 RNAi. These fragments, which they termed short interfering RNAs (siRNAs) were shown to be generated by an RNase III-like processing reaction from long dsRNA. They also showed that chemically synthesized siRNA duplexes with overhanging 3' ends mediate efficient target RNA cleavage in the *Drosophila* lysate, and that the cleavage site is located near the center of the region spanned by the guiding siRNA. In addition, they

30 suggest that the direction of dsRNA processing determines whether sense or antisense target RNA can be cleaved by the siRNA-protein complex (Elbashir et al., *Genes Dev.*, **2001**, *15*, 188-200). Further characterization of the suppression of expression of endogenous and heterologous genes caused by the 21-23 nucleotide siRNAs have been

investigated in several mammalian cell lines, including human embryonic kidney (293) and HeLa cells (Elbashir et al., *Nature*, **2001**, *411*, 494-498).

Most recently, Tijsterman et al. have shown that, in fact, single-stranded RNA oligomers of antisense polarity can be potent inducers of gene silencing. As is the case for co-suppression, they showed that antisense RNAs act independently of the RNAi genes *rde-1* and *rde-4* but require the mutator/RNAi gene *mut-7* and a putative DEAD box RNA helicase, *mut-14*. According to the authors, their data favor the hypothesis that gene silencing is accomplished by RNA primer extension using the mRNA as template, leading to dsRNA that is subsequently degraded suggesting that single-stranded RNA oligomers are ultimately responsible for the RNAi phenomenon (Tijsterman et al., *Science*, **2002**, *295*, 694-697).

Several recent publications have described the structural requirements for the dsRNA trigger required for RNAi activity. Recent reports have indicated that ideal dsRNA sequences are 21nt in length containing 2 nt 3'-end overhangs (Elbashir et al, EMBO (2001), *20*, 6877-6887, Sabine Brantl, *Biochimica et Biophysica Acta*, **2002**, *1575*, 15-25.) In this system, substitution of the 4 nucleosides from the 3'-end with 2'-deoxynucleosides has been demonstrated to not affect activity. On the other hand, substitution with 2'-deoxynucleosides or 2'-OMe-nucleosides throughout the sequence (sense or antisense) was shown to be deleterious to RNAi activity.

Investigation of the structural requirements for RNA silencing in *C. elegans* has demonstrated modification of the internucleotide linkage (phosphorothioate) to not interfere with activity (Parrish et al., *Molecular Cell*, **2000**, *6*, 1077-1087.) It was also shown by Parrish et al., that chemical modification like 2'-amino or 5'-iodouridine are well tolerated in the sense strand but not the antisense strand of the dsRNA suggesting differing roles for the 2 strands in RNAi. Base modification such as guanine to inosine (where one hydrogen bond is lost) has been demonstrated to decrease RNAi activity independently of the position of the modification (sense or antisense). Same "position independent" loss of activity has been observed following the introduction of mismatches in the dsRNA trigger. Some types of modifications, for example introduction of sterically demanding bases such as 5-iodoU, have been shown to be deleterious to RNAi activity when positioned in the antisense strand, whereas modifications positioned in the sense strand were shown to be less detrimental to RNAi activity. As was the case for the 21 nt dsRNA sequences, RNA-DNA heteroduplexes did not serve as triggers for RNAi. However, dsRNA containing 2'-F-2'-deoxynucleosides

appeared to be efficient in triggering RNAi response independent of the position (sense or antisense) of the 2'-F-2'-deoxynucleosides.

In one experiment the reduction of gene expression was studied using electroporated dsRNA and a 25mer morpholino in post implantation mouse embryos  
5 (Mellitzer *et al.*, *Mechanisms of Development*, **2002**, 118, 57-63). The morpholino oligomer did show activity but was not as effective as the dsRNA.

A number of PCT applications have recently been published that relate to the RNAi phenomenon. These include: PCT publication WO 00/44895; PCT publication WO 00/49035; PCT publication WO 00/63364; PCT publication WO 01/36641; PCT  
10 publication WO 01/36646; PCT publication WO 99/32619; PCT publication WO 00/44914; PCT publication WO 01/29058; and PCT publication WO 01/75164.

U.S. patents 5,898,031 and 6,107,094, each of which is commonly owned with this application and each of which is herein incorporated by reference, describe certain oligonucleotides having RNA like properties. When hybridized with RNA, these  
15 oligonucleotides serve as substrates for a dsRNase enzyme with resultant cleavage of the RNA by the enzyme.

In another recently published paper (Martinez *et al.*, *Cell*, **2002**, 110, 563-574) it was shown that double stranded as well as single stranded siRNA resides in the RNA-induced silencing complex (RISC) together with eIF2C1 and eIF2C2 (human GERp950 Argonaute  
20 proteins. The activity of 5'-phosphorylated single stranded siRNA was comparable to the double stranded siRNA in the system studied. In a related study, the inclusion of a 5'-phosphate moiety was shown to enhance activity of siRNA's *in vivo* in *Drosophila* embryos (Boutla, et al., *Curr. Biol.*, 2001, 11, 1776-1780). In another study, it was reported that the 5'-phosphate was required for siRNA function in human HeLa cells (Schwarz *et al.*, *Molecular Cell*, **2002**, 10,  
25 537-548).

In one recently published paper the authors claim that inclusion of 2'-O-methyl groups into the sense, antisense or both the sense and antisense strands of a siRNA showed greatly reduced activity (Chiu, Ya-Lin and Rana, Tariq, M., *RNA*, **2003**, 9, 1034-1048).

Like the RNase H pathway, the RNA interference pathway of antisense modulation of  
30 gene expression is an effective means for modulating the levels of specific gene products and may therefore prove to be uniquely useful in a number of therapeutic, diagnostic, and research applications involving gene silencing. The present invention therefore further provides compositions useful for modulating gene expression pathways, including those relying on an antisense mechanism of action such as RNA interference and dsRNA enzymes as well as non-

antisense mechanisms. One having skill in the art, once armed with this disclosure will be able, without undue experimentation, to identify preferred compositions for these uses.

### Summary of the Invention

5           The present invention provides compositions comprising a first oligomeric compound and a second oligomeric compound, wherein at least a portion of the first oligomeric compound is capable of hybridizing with at least a portion of the second oligomeric compound. At least a portion of the first oligomeric compound is complementary to and capable of hybridizing to a selected target nucleic acid. One of  
10   the first and the second oligomeric compounds comprises a plurality of linked nucleosides linked by internucleoside linking groups and the other one of the first and the second oligomeric compounds comprises a plurality of linked nucleosides linked by internucleoside linking groups and wherein essentially each of the nucleosides is other than 2'-OH and have 3'-endo conformational geometry. The first and second oligomeric  
15   compounds optionally comprise at least one phosphate group, a 5' or 3'-overhang or a conjugate group.

          In one embodiment the first oligomeric compound comprises a plurality of linked nucleosides linked by internucleoside linking groups and wherein essentially each of the nucleosides is other than 2'-OH and have 3'-endo conformational geometry. In another  
20   embodiment first oligomeric compound comprises a plurality of linked nucleosides linked by internucleoside linking groups and wherein essentially each of the nucleosides is other than 2'-OH and have 3'-endo conformational geometry and each of the nucleosides of the second oligomeric compound has 3'-endo conformational geometry.

          In one embodiment the second oligomeric compound comprises a plurality of  
25   linked nucleosides linked by internucleoside linking groups and wherein essentially each of the nucleosides is other than 2'-OH and have 3'-endo conformational geometry. In another embodiment second oligomeric compound comprises a plurality of linked nucleosides linked by internucleoside linking groups and wherein essentially each of the nucleosides is other than 2'-OH and have 3'-endo conformational geometry and each of  
30   the nucleosides of the first oligomeric compound has 3'-endo conformational geometry.

          In one embodiment of the present invention each of the nucleosides of the first oligomeric compound comprise a  $\beta$ -D-ribofuranose sugar group. In another embodiment 3'-terminus of the first oligomeric compound comprises a stabilizing or conjugate group where preferred stabilizing groups include capping groups and terminal dTdT dimers. In

a further embodiment the 3'-terminus of the first oligomeric compound comprises a conjugate group.

In one embodiment of the present invention the first oligomeric compound comprises a 5'-phosphate group. In another embodiment the 5'-terminus of the first  
5 oligomeric compound comprises a stabilizing or conjugate group where preferred stabilizing groups include capping groups. In a further embodiment the 5'-terminus of the first oligomeric compound comprises a conjugate group. In one embodiment the second oligomeric compound comprises a 5'-phosphate group.

In one embodiment of the present invention each of the internucleoside linking  
10 groups of the first oligomeric compound is, independently, a phosphodiester or a phosphorothioate. In another embodiment the internucleoside linking groups of the first oligomeric compound is a phosphodiester. In a further embodiment the internucleoside linking groups of the first oligomeric compound is a phosphorothioate.

In one embodiment of the present invention each of the internucleoside linking  
15 groups of the second oligomeric compound is, independently, a phosphodiester or a phosphorothioate. In another embodiment each of the internucleoside linking groups of the second oligomeric compound is a phosphodiester. In a further embodiment each of the internucleoside linking groups of the second oligomeric compound is a phosphorothioate.

20 In one embodiment of the present invention the 3'-terminus of the second oligomeric compound comprises a stabilizing or conjugate group where preferred stabilizing groups include capping groups and dTdT dimers. In another embodiment the 3'-terminus of the second oligomeric compound comprises a conjugate group.

In one embodiment of the present invention the 5'-terminus of the second  
25 oligomeric compound comprises a stabilizing or conjugate group where preferred stabilizing groups include capping groups. In another embodiment the 5'-terminus of the second oligomeric compound comprises a conjugate group.

In one embodiment of the present invention at least one of the nucleosides having  
3'-endo conformational geometry has a 2'-substituent group. In a further embodiment  
30 each of the 2'-substituent groups is, independently, -F, -O-CH<sub>2</sub>CH<sub>2</sub>-O-CH<sub>3</sub>, -O-CH<sub>3</sub>, -O-CH<sub>2</sub>-CH=CH<sub>2</sub> or a group having one of formula I<sub>a</sub> or II<sub>a</sub>:



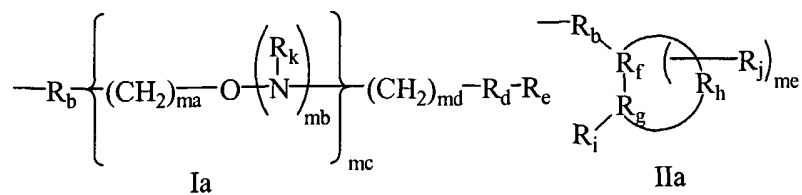

wherein:

$R_b$  is O, S or NH;

$R_d$  is a single bond, O, S or C(=O);

5  $R_e$  is  $C_1$ - $C_{10}$  alkyl,  $N(R_k)(R_m)$ ,  $N(R_k)(R_n)$ ,  $N=C(R_p)(R_q)$ ,  $N=C(R_p)(R_r)$  or has formula IIIa;

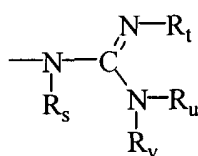

IIIa

$R_p$  and  $R_q$  are each independently hydrogen or  $C_1$ - $C_{10}$  alkyl;

10  $R_t$  is  $-R_x-R_y$ ;

each  $R_s$ ,  $R_t$ ,  $R_u$  and  $R_v$  is, independently, hydrogen,  $C(O)R_w$ , substituted or unsubstituted  $C_1$ - $C_{10}$  alkyl, substituted or unsubstituted  $C_2$ - $C_{10}$  alkenyl, substituted or unsubstituted  $C_2$ - $C_{10}$  alkynyl, alkylsulfonyl, arylsulfonyl, a chemical functional group or a conjugate group, wherein the substituent groups are selected from hydroxyl, amino, 15 alkoxy, carboxy, benzyl, phenyl, nitro, thiol, thioalkoxy, halogen, alkyl, aryl, alkenyl and alkynyl;

or optionally,  $R_u$  and  $R_v$ , together form a phthalimido moiety with the nitrogen atom to which they are attached;

each  $R_w$  is, independently, substituted or unsubstituted  $C_1$ - $C_{10}$  alkyl,

20 trifluoromethyl, cyanoethoxy, methoxy, ethoxy, t-butoxy, allyloxy, 9-fluorenylmethoxy, 2-(trimethylsilyl)-ethoxy, 2,2,2-trichloroethoxy, benzyloxy, butyryl, iso-butyryl, phenyl or aryl;

$R_k$  is hydrogen, a nitrogen protecting group or  $-R_x-R_y$ ;

$R_p$  is hydrogen, a nitrogen protecting group or  $-R_x-R_y$ ;

25  $R_x$  is a bond or a linking moiety;

$R_y$  is a chemical functional group, a conjugate group or a solid support medium;

each  $R_m$  and  $R_n$  is, independently, H, a nitrogen protecting group, substituted or unsubstituted  $C_1$ - $C_{10}$  alkyl, substituted or unsubstituted  $C_2$ - $C_{10}$  alkenyl, substituted or unsubstituted  $C_2$ - $C_{10}$  alkynyl, wherein the substituent groups are selected from hydroxyl, amino, alkoxy, carboxy, benzyl, phenyl, nitro, thiol, thioalkoxy, halogen, alkyl, aryl, alkenyl, alkynyl;  $NH_3^+$ ,  $N(R_u)(R_v)$ , guanidino and acyl where the acyl is an acid amide or an ester;

or  $R_m$  and  $R_n$ , together, are a nitrogen protecting group, are joined in a ring structure that optionally includes an additional heteroatom selected from N and O or are a chemical functional group;

10  $R_j$  is  $OR_z$ ,  $SR_z$ , or  $N(R_z)_2$ ;

each  $R_z$  is, independently, H,  $C_1$ - $C_8$  alkyl,  $C_1$ - $C_8$  haloalkyl,  $C(=NH)N(H)R_u$ ,  $C(=O)N(H)R_u$  or  $OC(=O)N(H)R_u$ ;

$R_f$ ,  $R_g$  and  $R_h$  comprise a ring system having from about 4 to about 7 carbon atoms or having from about 3 to about 6 carbon atoms and 1 or 2 heteroatoms wherein the heteroatoms are selected from oxygen, nitrogen and sulfur and wherein the ring system is aliphatic, unsaturated aliphatic, aromatic, or saturated or unsaturated heterocyclic;

$R_j$  is alkyl or haloalkyl having 1 to about 10 carbon atoms, alkenyl having 2 to about 10 carbon atoms, alkynyl having 2 to about 10 carbon atoms, aryl having 6 to about 14 carbon atoms,  $N(R_k)(R_m)$   $OR_k$ , halo,  $SR_k$  or CN;

$m_a$  is 1 to about 10;

each  $m_b$  is, independently, 0 or 1;

$m_c$  is 0 or an integer from 1 to 10;

$m_d$  is an integer from 1 to 10;

25  $m_e$  is from 0, 1 or 2; and

provided that when  $m_c$  is 0,  $m_d$  is greater than 1.

Preferred 2'-substituent groups include -F, -O- $CH_2CH_2$ -O- $CH_3$ , -O- $CH_3$ , -O- $CH_2$ - $CH=CH_2$  or -O- $CH_2$ - $CH$ - $CH_2$ - $NH(R_j)$  where  $R_j$  is H or  $C_1$ - $C_{10}$  alkyl. More preferred 2'-substituent groups include -F, -O- $CH_2CH_2$ -O- $CH_3$  or -O- $CH_3$ . A more preferred 2'-substituent groups is -O- $CH_3$ .

In one embodiment the each of the internucleoside linking groups of the first oligomeric compound is a phosphodiester where preferred internucleoside linking groups of the second oligomeric compound is a phosphodiester or phosphorothioate.

In one embodiment the second oligomeric compound comprises 2'-O-CH<sub>3</sub> as a preferred 2'-substituent group and each of the internucleoside linking groups of the first oligomeric compound is a phosphorothioate where preferred internucleoside linking groups of the second oligomeric compound is a phosphodiester or phosphorothioate.

5 In one embodiment the oligomeric compounds of the present invention comprise at least one conjugate group. In a preferred embodiment the conjugate group is a terminal cap moiety. In another preferred embodiment the conjugate group is attached to one or both of the 3'-terminal and 5'-terminal ends of the oligomeric compound. In an even more preferred embodiment the terminal cap moiety is an inverted deoxy abasic  
10 moiety.

In one embodiment the first and the second oligomeric compounds are a complementary pair of siRNA oligonucleotides. In another embodiment the first and the second oligomeric compounds are an antisense/sense pair of oligonucleotides.

In one embodiment of the present invention the first and the second oligomeric  
15 compounds are a complementary pair of siRNA oligonucleotides where the oligomeric compounds have 3'-dTdT overhangs. In another embodiment the first and the second oligomeric compounds are a complementary pair of siRNA oligonucleotides where the oligomeric compounds have blunt ends.

In one embodiment each of the first and second oligomeric compounds has 8 to  
20 80 nucleotides. In a preferred embodiment each of the first and second oligomeric compounds has 10 to 50 nucleotides. In a more preferred embodiment each of the first and second oligomeric compounds has 12 to 30 nucleotides. In an even more preferred embodiment each of the first and second oligomeric compounds has 12 to 24 nucleotides.

25 In a preferred embodiment the first oligomeric compound is an antisense oligonucleotide. In another preferred embodiment the second oligomeric compound is a sense oligonucleotide.

Also provided are methods of inhibiting gene expression comprising contacting one or more cells, a tissue or an animal with one or more compositions of the invention.  
30

### **Detailed Description of the Invention**

The present invention provides compositions of oligomeric compounds wherein at least a portion of the composition is double stranded region and a further portion of the composition is complementary to and hybridizes with a nucleic acid target. The

compositions can comprise a single strand with regions of self complementarity thereby forming a loop structure. More preferred compositions are double stranded comprising a first and second oligomeric compound where the first oligomeric compound hybridizes to the second oligomeric compound and further has a complementary region that  
5 hybridizes to a target nucleic acid. In this capacity the first oligomeric compound is the antisense strand and the second oligomeric compound is the sense strand of the composition.

At least the nucleic acid target region of the first oligomeric compound has 3'-endo sugar conformational geometry. In one aspect the targeting region of the first  
10 oligomeric compound comprises native RNA nucleosides and in another aspect the targeting region comprises fully modified nucleosides that have 3'-endo conformational geometry but are other than 2'-OH. Another preferred modification of the first oligomeric compound is a 5'-phosphate group, a 5' or 3'-overhang or a conjugate group.

In one aspect the nucleosides of the hybridizing region of the second oligomeric  
15 compound comprise native RNA nucleosides and in another aspect the hybridizing region comprises fully modified nucleosides that have 3'-endo conformational geometry but are other than 2'-OH. Another preferred modification of the second oligomeric compound is a 5'-phosphate group, a 5' or 3'-overhang or a conjugate group.

As a double stranded construct at least one of the first or second oligomeric  
20 compounds has a region of nucleosides having 3'-endo conformational geometry that are other than 2'-OH. This region can comprise a single modification or multiple modifications including nucleobase, sugar and internucleoside linkage modifications that will give the desired 3'-endo conformational geometry. Preferred modifications include 2'-modified ribofuranosyl sugar moieties, 4'-thio modified ribofuranosyl moieties and  
25 bicyclic sugar moieties having a 4'-CH<sub>2</sub>-O-2'-bridge (LNA) or ribofuranosyl moieties each having a 4'-(CH<sub>2</sub>)<sub>2</sub>-O-2'-bridge (ENA<sup>TM</sup>). In a preferred motif the modified oligomeric compound is fully modified.

In one aspect of the present invention the first oligomeric compound is a full phosphodiester or phosphorothioate RNA that can include a 5'-phosphate group and the  
30 second oligomeric compound is a fully modified phosphodiester or phosphorothioate such that each monomeric subunit has 3'-endo sugar conformational geometry. Preferred 3'-endo modifications include without limitation, -F, -O-CH<sub>2</sub>CH<sub>2</sub>-O-CH<sub>3</sub>, -O-CH<sub>3</sub>, -O-CH<sub>2</sub>-CH=CH<sub>2</sub> or -O-CH<sub>2</sub>-CH-CH<sub>2</sub>-NH(R<sub>j</sub>) where R<sub>j</sub> is H or C<sub>1</sub>-C<sub>10</sub> alkyl with 2'-O-methy as a more preferred group. The presense of modifications in both the sense and

the antisense strand of compositions of the present invention greatly enhances the stability of the corresponding compositions.

In one aspect of the present invention the first oligomeric compound is fully modified with a mixture of 2'-OCH<sub>3</sub> groups and 2'-F groups and the sense strand is unmodified RNA. The mixed of 2'-OCH<sub>3</sub> groups and 2'-F groups can be in any positions  
5 in the strand but it is preferred that the 5'-end of the antisense strand is a 2'-F. The 3'-end of the antisense strand can have a terminal 2'-OCH<sub>3</sub> group or a 2'-F group.

Compositions of the present invention will be useful for the modulation of gene expression. In one aspect of the present invention a targeted cell, group of cells, a tissue  
10 or an animal is contacted with a composition of the invention to effect reduction of message that can directly inhibit gene expression. In another embodiment the reduction of message indirectly upregulates a non-targeted gene through a pathway that relates the targeted gene to a non-targeted gene. Methods and models for the regulation of genes using oligomeric compounds of the invention are illustrated in the examples.

In another aspect a method of inhibiting gene expression is disclosed comprising  
15 contacting one or more cells, a tissue or an animal with a composition of the invention. Numerous procedures of how to use the compositions of the present invention are illustrated in the examples section.

Compositions of the invention modulate gene expression by hybridizing to a  
20 nucleic acid target resulting in loss of its normal function. As used herein, the term "target nucleic acid" or "nucleic acid target" is used for convenience to encompass any nucleic acid capable of being targeted including without limitation DNA, RNA (including pre-mRNA and mRNA or portions thereof) transcribed from such DNA, and also cDNA derived from such RNA. In a preferred embodiment of the invention the  
25 target nucleic acid is a messenger RNA. In a further preferred embodiment the degradation of the targeted messenger RNA is facilitated by a RISC complex that is formed with oligomeric compounds of the invention. In another preferred embodiment the degradation of the targeted messenger RNA is facilitated by a nuclease such as RNaseH.

The hybridization of an oligomeric compound of this invention with its target  
30 nucleic acid is generally referred to as "antisense". Consequently, the preferred mechanism in the practice of some preferred embodiments of the invention is referred to herein as "antisense inhibition." Such antisense inhibition is typically based upon hydrogen bonding-based hybridization of oligonucleotide strands or segments such that

at least one strand or segment is cleaved, degraded, or otherwise rendered inoperable. In this regard, it is presently preferred to target specific nucleic acid molecules and their functions for such antisense inhibition.

The functions of DNA to be interfered with can include replication and  
5 transcription. Replication and transcription, for example, can be from an endogenous cellular template, a vector, a plasmid construct or otherwise. The functions of RNA to be interfered with can include functions such as translocation of the RNA to a site of protein translation, translocation of the RNA to sites within the cell which are distant from the site of RNA synthesis, translation of protein from the RNA, splicing of the  
10 RNA to yield one or more RNA species, and catalytic activity or complex formation involving the RNA which may be engaged in or facilitated by the RNA. In the context of the present invention, "modulation" and "modulation of expression" mean either an increase (stimulation) or a decrease (inhibition) in the amount or levels of a nucleic acid molecule encoding the gene, e.g., DNA or RNA. Inhibition is often the preferred form  
15 of modulation of expression and mRNA is often a preferred target nucleic acid.

The compositions and methods of the present invention are also useful in the study, characterization, validation and modulation of small non-coding RNAs. These include, but are not limited to, microRNAs (miRNA), small nuclear RNAs (snRNA),  
20 small nucleolar RNAs (snoRNA), small temporal RNAs (stRNA) and tiny non-coding RNAs (tncRNA) or their precursors or processed transcripts or their association with other cellular components.

Small non-coding RNAs have been shown to function in various developmental and regulatory pathways in a wide range of organisms, including plants, nematodes and mammals. MicroRNAs are small non-coding RNAs that are processed from larger  
25 precursors by enzymatic cleavage and inhibit translation of mRNAs. stRNAs, while processed from precursors much like miRNAs, have been shown to be involved in developmental timing regulation. Other non-coding small RNAs are involved in events as diverse as cellular splicing of transcripts, translation, transport, and chromosome organization.

30 As modulators of small non-coding RNA function, the compositions of the present invention find utility in the control and manipulation of cellular functions or processes such as regulation of splicing, chromosome packaging or methylation, control of developmental timing events, increase or decrease of target RNA expression levels depending on the timing of delivery into the specific biological pathway and translational

or transcriptional control. In addition, the compositions of the present invention can be modified in order to optimize their effects in certain cellular compartments, such as the cytoplasm, nucleus, nucleolus or mitochondria.

The compositions of the present invention can further be used to identify  
5 components of regulatory pathways of RNA processing or metabolism as well as in screening assays or devices.

### **Oligomeric Compounds**

In the context of the present invention, the term "oligomeric compound" refers to  
10 a polymeric structure capable of hybridizing a region of a nucleic acid molecule. This term includes oligonucleotides, oligonucleosides, oligonucleotide analogs, oligonucleotide mimetics and combinations of these. Oligomeric compounds are routinely prepared linearly but can be joined or otherwise prepared to be circular and may also include branching. Oligomeric compounds can include double stranded  
15 constructs such as for example two strands hybridized to form double stranded compounds. The double stranded compounds can be linked or separate and can include overhangs on the ends. In general an oligomeric compound comprises a backbone of linked monomeric subunits where each linked monomeric subunit is directly or indirectly attached to a heterocyclic base moiety. Oligomeric compounds may also include  
20 monomeric subunits that are not linked to a heterocyclic base moiety thereby providing abasic sites. The linkages joining the monomeric subunits, the sugar moieties or surrogates and the heterocyclic base moieties can be independently modified giving rise to a plurality of motifs for the resulting oligomeric compounds including hemimers, gapmers and chimeras.

25 As is known in the art, a nucleoside is a base-sugar combination. The base portion of the nucleoside is normally a heterocyclic base moiety. The two most common classes of such heterocyclic bases are purines and pyrimidines. Nucleotides are nucleosides that further include a phosphate group covalently linked to the sugar portion of the nucleoside. For those nucleosides that include a pentofuranosyl sugar, the  
30 phosphate group can be linked to either the 2', 3' or 5' hydroxyl moiety of the sugar. In forming oligonucleotides, the phosphate groups covalently link adjacent nucleosides to one another to form a linear polymeric compound. The respective ends of this linear polymeric structure can be joined to form a circular structure by hybridization or by formation of a covalent bond, however, open linear structures are generally preferred.

Within the oligonucleotide structure, the phosphate groups are commonly referred to as forming the internucleoside linkages of the oligonucleotide. The normal internucleoside linkage of RNA and DNA is a 3' to 5' phosphodiester linkage.

In the context of this invention, the term "oligonucleotide" refers to an oligomer  
5 or polymer of ribonucleic acid (RNA) or deoxyribonucleic acid (DNA). This term includes oligonucleotides composed of naturally-occurring nucleobases, sugars and covalent internucleoside linkages. The term "oligonucleotide analog" refers to oligonucleotides that have one or more non-naturally occurring portions which function in a similar manner to oligonucleotides. Such non-naturally occurring oligonucleotides  
10 are often preferred to the naturally occurring forms because of desirable properties such as, for example, enhanced cellular uptake, enhanced affinity for nucleic acid target and increased stability in the presence of nucleases.

In the context of this invention, the term "oligonucleoside" refers to a sequence of nucleosides that are joined by internucleoside linkages that do not have phosphorus  
15 atoms. Internucleoside linkages of this type include short chain alkyl, cycloalkyl, mixed heteroatom alkyl, mixed heteroatom cycloalkyl, one or more short chain heteroatomic and one or more short chain heterocyclic. These internucleoside linkages include but are not limited to siloxane, sulfide, sulfoxide, sulfone, acetyl, formacetyl, thioformacetyl, methylene formacetyl, thioformacetyl, alkenyl, sulfamate; methyleneimino,  
20 methylenehydrazino, sulfonate, sulfonamide, amide and others having mixed N, O, S and CH<sub>2</sub> component parts.

Representative United States patents that teach the preparation of the above oligonucleosides include, but are not limited to, U.S.: 5,034,506; 5,166,315; 5,185,444; 5,214,134; 5,216,141; 5,235,033; 5,264,562; 5,264,564; 5,405,938; 5,434,257;  
25 5,466,677; 5,470,967; 5,489,677; 5,541,307; 5,561,225; 5,596,086; 5,602,240; 5,610,289; 5,602,240; 5,608,046; 5,610,289; 5,618,704; 5,623,070; 5,663,312; 5,633,360; 5,677,437; 5,792,608; 5,646,269 and 5,677,439, certain of which are commonly owned with this application, and each of which is herein incorporated by reference.

30 Further included in the present invention are oligomeric compounds such as antisense oligomeric compounds, antisense oligonucleotides, ribozymes, external guide sequence (EGS) oligonucleotides, alternate splicers, primers, probes, and other oligomeric compounds which hybridize to at least a portion of the target nucleic acid. As such, these oligomeric compounds may be introduced in the form of single-stranded,



double-stranded, circular or hairpin oligomeric compounds and may contain structural elements such as internal or terminal bulges or loops. Once introduced to a system, the oligomeric compounds of the invention may elicit the action of one or more enzymes or structural proteins to effect modification of the target nucleic acid.

5           One non-limiting example of such an enzyme is RNase H, a cellular endonuclease which cleaves the RNA strand of an RNA:DNA duplex. It is known in the art that single-stranded antisense oligomeric compounds which are "DNA-like" elicit RNase H. Activation of RNase H, therefore, results in cleavage of the RNA target, thereby greatly enhancing the efficiency of oligonucleotide-mediated inhibition of gene  
10 expression. Similar roles have been postulated for other ribonucleases such as those in the RNase III and ribonuclease L family of enzymes.

          While the preferred form of antisense oligomeric compound is a single-stranded antisense oligonucleotide, in many species the introduction of double-stranded structures, such as double-stranded RNA (dsRNA) molecules, has been shown to induce potent and  
15 specific antisense-mediated reduction of the function of a gene or its associated gene products. This phenomenon occurs in both plants and animals and is believed to have an evolutionary connection to viral defense and transposon silencing.

          In addition to the modifications described above, the nucleosides of the oligomeric compounds of the invention can have a variety of other modification so long  
20 as these other modifications either alone or in combination with other nucleosides enhance one or more of the desired properties described above. Thus, for nucleotides that are incorporated into oligonucleotides of the invention, these nucleotides can have sugar portions that correspond to naturally-occurring sugars or modified sugars. Representative modified sugars include carbocyclic or acyclic sugars, sugars having  
25 substituent groups at one or more of their 2', 3' or 4' positions and sugars having substituents in place of one or more hydrogen atoms of the sugar. Additional nucleosides amenable to the present invention having altered base moieties and or altered sugar moieties are disclosed in United States Patent 3,687,808 and PCT application PCT/US89/02323.

30           Altered base moieties or altered sugar moieties also include other modifications consistent with the spirit of this invention. Such oligonucleotides are best described as being structurally distinguishable from, yet functionally interchangeable with, naturally occurring or synthetic wild type oligonucleotides. All such oligonucleotides are comprehended by this invention so long as they function effectively to mimic the

structure of a desired RNA or DNA strand. A class of representative base modifications include tricyclic cytosine analog, termed "G clamp" (Lin, *et al.*, *J. Am. Chem. Soc.* 1998, 120, 8531). This analog makes four hydrogen bonds to a complementary guanine (G) within a helix by simultaneously recognizing the Watson-Crick and Hoogsteen faces of the targeted G. This G clamp modification when incorporated into phosphorothioate oligonucleotides, dramatically enhances antisense potencies in cell culture. The oligonucleotides of the invention also can include phenoxazine-substituted bases of the type disclosed by Flanagan, *et al.*, *Nat. Biotechnol.* 1999, 17(1), 48-52.

The oligomeric compounds in accordance with this invention preferably comprise from about 8 to about 80 nucleobases (i.e. from about 8 to about 80 linked nucleosides and/or monomeric subunits). One of ordinary skill in the art will appreciate that the invention embodies oligomeric compounds of 8, 9, 10, 11, 12, 13, 14, 15, 16, 17, 18, 19, 20, 21, 22, 23, 24, 25, 26, 27, 28, 29, 30, 31, 32, 33, 34, 35, 36, 37, 38, 39, 40, 41, 42, 43, 44, 45, 46, 47, 48, 49, 50, 51, 52, 53, 54, 55, 56, 57, 58, 59, 60, 61, 62, 63, 64, 65, 66, 67, 68, 69, 70, 71, 72, 73, 74, 75, 76, 77, 78, 79, or 80 nucleobases in length.

In one preferred embodiment, the oligomeric compounds of the invention are 10 to 50 nucleobases in length. One having ordinary skill in the art will appreciate that this embodies oligomeric compounds of 12, 13, 14, 15, 16, 17, 18, 19, 20, 21, 22, 23, 24, 25, 26, 27, 28, 29, 30, 31, 32, 33, 34, 35, 36, 37, 38, 39, 40, 41, 42, 43, 44, 45, 46, 47, 48, 49, or 50 nucleobases in length.

In another preferred embodiment, the oligomeric compounds of the invention are 12 to 30 nucleobases in length. One having ordinary skill in the art will appreciate that this embodies oligomeric compounds of 12, 13, 14, 15, 16, 17, 18, 19, 20, 21, 22, 23, 24, 25, 26, 27, 28, 29, or 30 nucleobases in length.

In a further preferred embodiment, the oligomeric compounds of the invention are 12 to 24 nucleobases in length. One having ordinary skill in the art will appreciate that this embodies oligomeric compounds of 12, 13, 14, 15, 16, 17, 18, 19, 20, 21, 22, 23 or 24 nucleobases in length.

In another preferred embodiment, the oligomeric compounds of the invention are 19 to 23 nucleobases in length. One having ordinary skill in the art will appreciate that this embodies oligomeric compounds of 19, 20, 21, 22 or 23 nucleobases in length.

One particularly preferred length for oligomeric compounds is from about 12 to about 30 nucleobases. Another particularly preferred length is from about 12 to about 24

nucleobases. A further particularly preferred length is from about 19 to about 23 nucleobases.

Oligomeric compounds used in the compositions of the present invention can also be modified to have one or more stabilizing groups that are generally attached to one or both termini of oligomeric compounds to enhance properties such as for example  
5 nuclease stability. Included in stabilizing groups are cap structures. By "cap structure or terminal cap moiety" is meant chemical modifications, which have been incorporated at either terminus of oligonucleotides (see for example Wincott et al., WO 97/26270, incorporated by reference herein). These terminal modifications protect the oligomeric  
10 compounds having terminal nucleic acid molecules from exonuclease degradation, and can help in delivery and/or localization within a cell. The cap can be present at the 5'-terminus (5'-cap) or at the 3'-terminus (3'-cap) or can be present on both termini. In non-limiting examples, the 5'-cap includes inverted abasic residue (moiety), 4',5'-methylene nucleotide; 1-(beta-D-erythrofuransyl) nucleotide, 4'-thio nucleotide, carbocyclic  
15 nucleotide; 1,5-anhydrohexitol nucleotide; L-nucleotides; alpha-nucleotides; modified base nucleotide; phosphorodithioate linkage; threo-pentofuransyl nucleotide; acyclic 3',4'-seco nucleotide; acyclic 3,4-dihydroxybutyl nucleotide; acyclic 3,5-dihydroxypentyl  
riucleotide, 3'-3'-inverted nucleotide moiety; 3'-3'-inverted abasic moiety; 3'-2'-inverted nucleotide moiety; 3'-2'-inverted abasic moiety; 1,4-butanediol phosphate; 3'-  
20 phosphoramidate; hexylphosphate; aminohexyl phosphate; 3'-phosphate; 3'-phosphorothioate; phosphorodithioate; or bridging or non-bridging methylphosphonate moiety (for more details see Wincott et al., International PCT publication No. WO  
97/26270, incorporated by reference herein).

Particularly preferred 3'-cap structures of the present invention include, for  
25 example 4',5'-methylene nucleotide; 1-(beta-D-erythrofuransyl) nucleotide; 4'-thio nucleotide, carbocyclic nucleotide; 5'-amino-alkyl phosphate; 1,3-diamino-2-propyl phosphate, 3-aminopropyl phosphate; 6-aminohexyl phosphate; 1,2-aminododecyl phosphate; hydroxypropyl phosphate; 1,5-anhydrohexitol nucleotide; L-nucleotide; alpha-nucleotide; modified base nucleotide; phosphorodithioate; threo-pentofuransyl  
30 nucleotide; acyclic 3',4'-seco nucleotide; 3,4-dihydroxybutyl nucleotide; 3,5-dihydroxypentyl nucleotide, 5'-5'-inverted nucleotide moiety; 5'-5'-inverted abasic moiety; 5'-phosphoramidate; 5'-phosphorothioate; 1,4-butanediol phosphate; 5'-amino; bridging and/or non-bridging 5'-phosphoramidate, phosphorothioate and/or  
phosphorodithioate, bridging or non bridging methylphosphonate and 5'-mercapto

moieties (for more details see Beaucage and Tyer, 1993, Tetrahedron 49, 1925; incorporated by reference herein).

### **Oligomer and Monomer Modifications**

5           As is known in the art, a nucleoside is a base-sugar combination. The base portion of the nucleoside is normally a heterocyclic base. The two most common classes of such heterocyclic bases are the purines and the pyrimidines. Nucleotides are nucleosides that further include a phosphate group covalently linked to the sugar portion of the nucleoside. For those nucleosides that include a pentofuranosyl sugar, the  
10 phosphate group can be linked to either the 2', 3' or 5' hydroxyl moiety of the sugar. In forming oligonucleotides, the phosphate groups covalently link adjacent nucleosides to one another to form a linear polymeric compound. In turn, the respective ends of this linear polymeric compound can be further joined to form a circular compound, however, linear compounds are generally preferred. In addition, linear compounds may have  
15 internal nucleobase complementarity and may therefore fold in a manner as to produce a fully or partially double-stranded compound. Within oligonucleotides, the phosphate groups are commonly referred to as forming the internucleoside linkage or in conjunction with the sugar ring the backbone of the oligonucleotide. The normal internucleoside linkage that makes up the backbone of RNA and DNA is a 3' to 5'  
20 phosphodiester linkage.

### **Chimeric oligomeric compounds**

          It is not necessary for all positions in a oligomeric compound to be uniformly modified, and in fact more than one of the aforementioned modifications may be  
25 incorporated in a single oligomeric compound or even at a single monomeric subunit such as a nucleoside within a oligomeric compound. The present invention also includes oligomeric compounds which are chimeric oligomeric compounds. "Chimeric" oligomeric compounds or "chimeras," in the context of this invention, are oligomeric compounds containing two or more chemically distinct regions, each made up of at least  
30 one monomer unit, i.e., a nucleotide in the case of a nucleic acid based oligomer.

          Chimeric oligomeric compounds typically contain at least one region modified so as to confer increased resistance to nuclease degradation, increased cellular uptake, and/or increased binding affinity for the target nucleic acid. An additional region of the oligomeric compound may serve as a substrate for enzymes capable of cleaving

RNA:DNA or RNA:RNA hybrids. By way of example, RNase H is a cellular endonuclease which cleaves the RNA strand of an RNA:DNA duplex. Activation of RNase H, therefore, results in cleavage of the RNA target, thereby greatly enhancing the efficiency of inhibition of gene expression. Consequently, comparable results can often  
5 be obtained with shorter oligomeric compounds when chimeras are used, compared to for example phosphorothioate deoxyoligonucleotides hybridizing to the same target region. Cleavage of the RNA target can be routinely detected by gel electrophoresis and, if necessary, associated nucleic acid hybridization techniques known in the art.

Chimeric oligomeric compounds of the invention may be formed as composite  
10 structures of two or more oligonucleotides, oligonucleotide analogs, oligonucleosides and/or oligonucleotide mimetics as described above. Such oligomeric compounds have also been referred to in the art as hybrids hemimers, gapmers or inverted gapmers. Representative United States patents that teach the preparation of such hybrid structures include, but are not limited to, U.S.: 5,013,830; 5,149,797; 5,220,007; 5,256,775;  
15 5,366,878; 5,403,711; 5,491,133; 5,565,350; 5,623,065; 5,652,355; 5,652,356; and 5,700,922, certain of which are commonly owned with the instant application, and each of which is herein incorporated by reference in its entirety.

### **Oligomer Mimetics**

20 Another preferred group of oligomeric compounds amenable to the present invention includes oligonucleotide mimetics. The term mimetic as it is applied to oligonucleotides is intended to include oligomeric compounds wherein only the furanose ring or both the furanose ring and the internucleotide linkage are replaced with novel groups, replacement of only the furanose ring is also referred to in the art as being a  
25 sugar surrogate. The heterocyclic base moiety or a modified heterocyclic base moiety is maintained for hybridization with an appropriate target nucleic acid. One such oligomeric compound, an oligonucleotide mimetic that has been shown to have excellent hybridization properties, is referred to as a peptide nucleic acid (PNA). In PNA oligomeric compounds, the sugar-backbone of an oligonucleotide is replaced with an  
30 amide containing backbone, in particular an aminoethylglycine backbone. The nucleobases are retained and are bound directly or indirectly to aza nitrogen atoms of the amide portion of the backbone. Representative United States patents that teach the preparation of PNA oligomeric compounds include, but are not limited to, U.S.: 5,539,082; 5,714,331; and 5,719,262, each of which is herein incorporated by reference.

Further teaching of PNA oligomeric compounds can be found in Nielsen *et al.*, *Science*, 1991, 254, 1497-1500.

One oligonucleotide mimetic that has been reported to have excellent hybridization properties, is peptide nucleic acids (PNA). The backbone in PNA compounds is two or more linked aminoethylglycine units which gives PNA an amide containing backbone. The heterocyclic base moieties are bound directly or indirectly to aza nitrogen atoms of the amide portion of the backbone. Representative United States patents that teach the preparation of PNA compounds include, but are not limited to, U.S.: 5,539,082; 5,714,331; and 5,719,262, each of which is herein incorporated by reference. Further teaching of PNA compounds can be found in Nielsen *et al.*, *Science*, 1991, 254, 1497-1500.

PNA has been modified to incorporate numerous modifications since the basic PNA structure was first prepared. The basic structure is shown below:

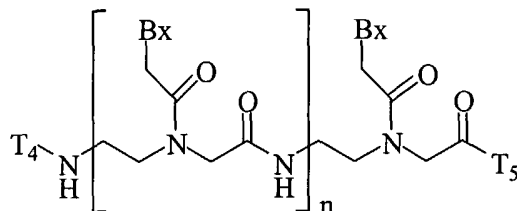

15 wherein

Bx is a heterocyclic base moiety;

T<sub>4</sub> is hydrogen, an amino protecting group, -C(O)R<sub>5</sub>, substituted or unsubstituted C<sub>1</sub>-C<sub>10</sub> alkyl, substituted or unsubstituted C<sub>2</sub>-C<sub>10</sub> alkenyl, substituted or unsubstituted C<sub>2</sub>-C<sub>10</sub> alkynyl, alkylsulfonyl, arylsulfonyl, a chemical functional group, a reporter group, a conjugate group, a D or L α-amino acid linked via the α-carboxyl group or optionally through the ω-carboxyl group when the amino acid is aspartic acid or glutamic acid or a peptide derived from D, L or mixed D and L amino acids linked through a carboxyl group, wherein the substituent groups are selected from hydroxyl, amino, alkoxy, carboxy, benzyl, phenyl, nitro, thiol, thioalkoxy, halogen, alkyl, aryl, alkenyl and alkynyl;

25

T<sub>5</sub> is -OH, -N(Z<sub>1</sub>)Z<sub>2</sub>, R<sub>5</sub>, D or L α-amino acid linked via the α-amino group or optionally through the ω-amino group when the amino acid is lysine or ornithine or a peptide derived from D, L or mixed D and L amino acids linked through an amino group, a chemical functional group, a reporter group or a conjugate group;

30

Z<sub>1</sub> is hydrogen, C<sub>1</sub>-C<sub>6</sub> alkyl, or an amino protecting group;

$Z_2$  is hydrogen,  $C_1$ - $C_6$  alkyl, an amino protecting group,  $-C(=O)-(CH_2)_n-J-Z_3$ , a D or L  $\alpha$ -amino acid linked via the  $\alpha$ -carboxyl group or optionally through the  $\omega$ -carboxyl group when the amino acid is aspartic acid or glutamic acid or a peptide derived from D, L or mixed D and L amino acids linked through a carboxyl group;

5  $Z_3$  is hydrogen, an amino protecting group,  $-C_1$ - $C_6$  alkyl,  $-C(=O)-CH_3$ , benzyl, benzoyl, or  $-(CH_2)_n-N(H)Z_1$ ;

each J is O, S or NH;

$R_5$  is a carbonyl protecting group; and

n is from 2 to about 50.

10 Another class of oligonucleotide mimetic that has been studied is based on linked morpholino units (morpholino nucleic acid) having heterocyclic bases attached to the morpholino ring. A number of linking groups have been reported that link the morpholino monomeric units in a morpholino nucleic acid. A preferred class of linking groups have been selected to give a non-ionic oligomeric compound. The non-ionic  
15 morpholino-based oligomeric compounds are less likely to have undesired interactions with cellular proteins. Morpholino-based oligomeric compounds are non-ionic mimics of oligonucleotides which are less likely to form undesired interactions with cellular proteins (Dwaine A. Braasch and David R. Corey, *Biochemistry*, **2002**, *41(14)*, 4503-4510). Morpholino-based oligomeric compounds are disclosed in United States Patent  
20 5,034,506, issued July 23, 1991. The morpholino class of oligomeric compounds have been prepared having a variety of different linking groups joining the monomeric subunits.

Morpholino nucleic acids have been prepared having a variety of different linking groups ( $L_2$ ) joining the monomeric subunits. The basic formula is shown below:

25

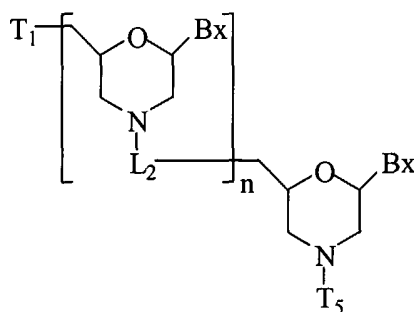

wherein

T<sub>1</sub> is hydroxyl or a protected hydroxyl;

T<sub>5</sub> is hydrogen or a phosphate or phosphate derivative;

L<sub>2</sub> is a linking group; and

5 n is from 2 to about 50.

A further class of oligonucleotide mimetic is referred to as cyclohexenyl nucleic acids (CeNA). The furanose ring normally present in an DNA/RNA molecule is replaced with a cyclohexenyl ring. CeNA DMT protected phosphoramidite monomers have been prepared and used for oligomeric compound synthesis following classical  
10 phosphoramidite chemistry. Fully modified CeNA oligomeric compounds and oligonucleotides having specific positions modified with CeNA have been prepared and studied (see Wang *et al.*, *J. Am. Chem. Soc.*, **2000**, *122*, 8595-8602). In general the incorporation of CeNA monomers into a DNA chain increases its stability of a  
15 DNA/RNA hybrid. CeNA oligoadenylates formed complexes with RNA and DNA complements with similar stability to the native complexes. The study of incorporating CeNA structures into natural nucleic acid structures was shown by NMR and circular dichroism to proceed with easy conformational adaptation. Furthermore the incorporation of CeNA into a sequence targeting RNA was stable to serum and able to activate E. Coli RNase resulting in cleavage of the target RNA strand.

20 The general formula of CeNA is shown below:

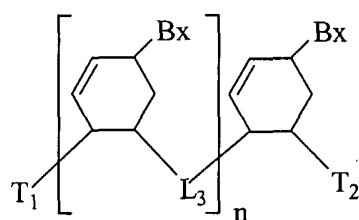

wherein

25 each Bx is a heterocyclic base moiety;

T<sub>1</sub> is hydroxyl or a protected hydroxyl; and

T<sub>2</sub> is hydroxyl or a protected hydroxyl.

Another class of oligonucleotide mimetic (anhydrohexitol nucleic acid) can be prepared from one or more anhydrohexitol nucleosides (see, Wouters and Herdewijn,  
30 *Bioorg. Med. Chem. Lett.*, **1999**, *9*, 1563-1566) and would have the general formula:



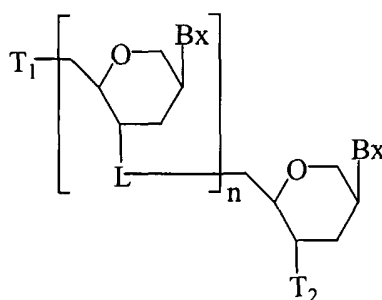

A further preferred modification includes Locked Nucleic Acids (LNAs) in which the 2'-hydroxyl group is linked to the 4' carbon atom of the sugar ring thereby forming a 2'-C,4'-C-oxymethylene linkage thereby forming a bicyclic sugar moiety. The linkage is preferably a methylene  $(-\text{CH}_2-)_n$  group bridging the 2' oxygen atom and the 4' carbon atom wherein  $n$  is 1 or 2 (Singh et al., Chem. Commun., 1998, 4, 455-456). LNA and LNA analogs display very high duplex thermal stabilities with complementary DNA and RNA ( $T_m = +3$  to  $+10$  C), stability towards 3'-exonucleolytic degradation and good solubility properties. The basic structure of LNA showing the bicyclic ring system is shown below:

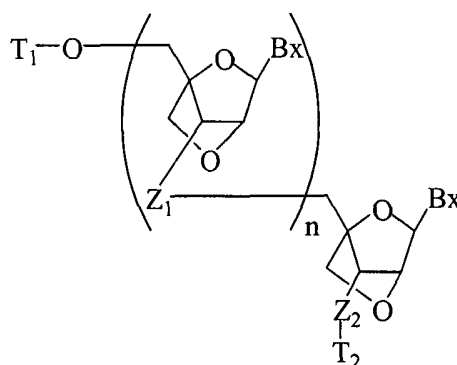

The conformations of LNAs determined by 2D NMR spectroscopy have shown that the locked orientation of the LNA nucleotides, both in single-stranded LNA and in duplexes, constrains the phosphate backbone in such a way as to introduce a higher population of the N-type conformation (Petersen et al., J. Mol. Recognit., 2000, 13, 44-53). These conformations are associated with improved stacking of the nucleobases (Wengel et al., Nucleosides Nucleotides, 1999, 18, 1365-1370).

LNA has been shown to form exceedingly stable LNA:LNA duplexes (Koshkin et al., J. Am. Chem. Soc., 1998, 120, 13252-13253). LNA:LNA hybridization was

shown to be the most thermally stable nucleic acid type duplex system, and the RNA-mimicking character of LNA was established at the duplex level. Introduction of 3 LNA monomers (T or A) significantly increased melting points ( $T_m = +15/+11$ ) toward DNA complements. The universality of LNA-mediated hybridization has been stressed by the  
5 formation of exceedingly stable LNA:LNA duplexes. The RNA-mimicking of LNA was reflected with regard to the N-type conformational restriction of the monomers and to the secondary structure of the LNA:RNA duplex.

LNAs also form duplexes with complementary DNA, RNA or LNA with high thermal affinities. Circular dichroism (CD) spectra show that duplexes involving fully  
10 modified LNA (esp. LNA:RNA) structurally resemble an A-form RNA:RNA duplex. Nuclear magnetic resonance (NMR) examination of an LNA:DNA duplex confirmed the 3'-endo conformation of an LNA monomer. Recognition of double-stranded DNA has also been demonstrated suggesting strand invasion by LNA. Studies of mismatched sequences show that LNAs obey the Watson-Crick base pairing rules with generally  
15 improved selectivity compared to the corresponding unmodified reference strands.

Novel types of LNA-oligomeric compounds, as well as the LNAs, are useful in a wide range of diagnostic and therapeutic applications. Among these are antisense applications, PCR applications, strand-displacement oligomers, substrates for nucleic acid polymerases and generally as nucleotide based drugs.  
20 Potent and nontoxic antisense oligonucleotides containing LNAs have been described (Wahlestedt et al., Proc. Natl. Acad. Sci. U. S. A., 2000, 97, 5633-5638.) The authors have demonstrated that LNAs confer several desired properties to antisense agents. LNA/DNA copolymers were not degraded readily in blood serum and cell extracts. LNA/DNA copolymers exhibited potent antisense activity in assay systems as disparate  
25 as G-protein-coupled receptor signaling in living rat brain and detection of reporter genes in *Escherichia coli*. Lipofectin-mediated efficient delivery of LNA into living human breast cancer cells has also been accomplished.

The synthesis and preparation of the LNA monomers adenine, cytosine, guanine, 5-methyl-cytosine, thymine and uracil, along with their oligomerization, and nucleic acid  
30 recognition properties have been described (Koshkin et al., Tetrahedron, 1998, 54, 3607-3630). LNAs and preparation thereof are also described in WO 98/39352 and WO 99/14226.

The first analogs of LNA, phosphorothioate-LNA and 2'-thio-LNAs, have also been prepared (Kumar et al., Bioorg. Med. Chem. Lett., 1998, 8, 2219-2222).

Preparation of locked nucleoside analogs containing oligodeoxyribonucleotide duplexes as substrates for nucleic acid polymerases has also been described (Wengel et al., PCT International Application WO 98-DK393 19980914). Furthermore, synthesis of 2'-amino-LNA, a novel conformationally restricted high-affinity oligonucleotide analog  
 5 with a handle has been described in the art (Singh et al., J. Org. Chem., 1998, 63, 10035-10039). In addition, 2'-Amino- and 2'-methylamino-LNA's have been prepared and the thermal stability of their duplexes with complementary RNA and DNA strands has been previously reported.

Further oligonucleotide mimetics have been prepared to include bicyclic and  
 10 tricyclic nucleoside analogs having the formulas (amidite monomers shown):

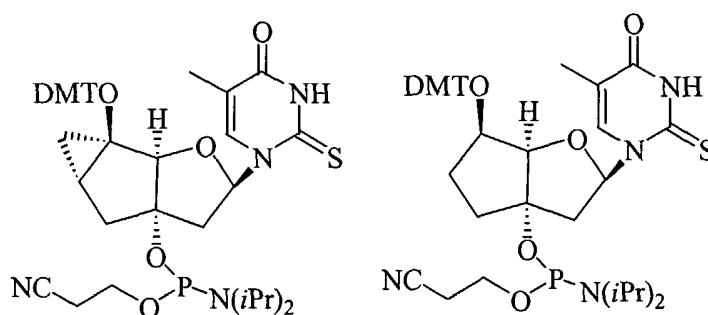

(see Steffens et al., *Helv. Chim. Acta*, 1997, 80, 2426-2439; Steffens et al., *J. Am. Chem. Soc.*, 1999, 121, 3249-3255; and Renneberg et al., *J. Am. Chem. Soc.*, 2002, 124, 5993-  
 15 6002). These modified nucleoside analogs have been oligomerized using the phosphoramidite approach and the resulting oligomeric compounds containing tricyclic nucleoside analogs have shown increased thermal stabilities ( $T_m$ 's) when hybridized to DNA, RNA and itself. Oligomeric compounds containing bicyclic nucleoside analogs have shown thermal stabilities approaching that of DNA duplexes.

Another class of oligonucleotide mimetic is referred to as phosphonomonoester  
 20 nucleic acids incorporate a phosphorus group in a backbone the backbone. This class of oligonucleotide mimetic is reported to have useful physical and biological and pharmacological properties in the areas of inhibiting gene expression (antisense oligonucleotides, ribozymes, sense oligonucleotides and triplex-forming  
 25 oligonucleotides), as probes for the detection of nucleic acids and as auxiliaries for use in molecular biology.

The general formula (for definitions of Markush variables see: United States Patents 5,874,553 and 6,127,346 herein incorporated by reference in their entirety) is shown below.

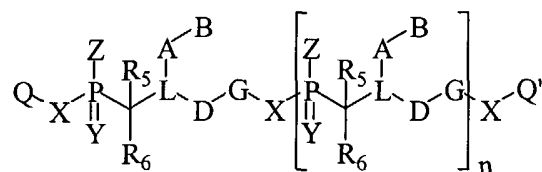

5

Another oligonucleotide mimetic has been reported wherein the furanosyl ring has been replaced by a cyclobutyl moiety.

### Modified Internucleoside Linkages

10 Specific examples of preferred antisense oligomeric compounds useful in this invention include oligonucleotides containing modified e.g. non-naturally occurring internucleoside linkages. As defined in this specification, oligonucleotides having modified internucleoside linkages include internucleoside linkages that retain a phosphorus atom and internucleoside linkages that do not have a phosphorus atom. For  
 15 the purposes of this specification, and as sometimes referenced in the art, modified oligonucleotides that do not have a phosphorus atom in their internucleoside backbone can also be considered to be oligonucleosides.

In the *C. elegans* system, modification of the internucleotide linkage (phosphorothioate) did not significantly interfere with RNAi activity. Based on this  
 20 observation, it is suggested that certain preferred oligomeric compounds of the invention can also have one or more modified internucleoside linkages. A preferred phosphorus containing modified internucleoside linkage is the phosphorothioate internucleoside linkage.

Preferred modified oligonucleotide backbones containing a phosphorus atom  
 25 therein include, for example, phosphorothioates, chiral phosphorothioates, phosphorodithioates, phosphotriesters, aminoalkylphosphotriesters, methyl and other alkyl phosphonates including 3'-alkylene phosphonates, 5'-alkylene phosphonates and chiral phosphonates, phosphinates, phosphoramidates including 3'-amino phosphoramidate and aminoalkylphosphoramidates, thionophosphoramidates, thionoalkylphosphonates,  
 30 thionoalkylphosphotriesters, selenophosphates and boranophosphates having normal 3'-5' linkages, 2'-5' linked analogs of these, and those having inverted polarity wherein one

or more internucleotide linkages is a 3' to 3', 5' to 5' or 2' to 2' linkage. Preferred oligonucleotides having inverted polarity comprise a single 3' to 3' linkage at the 3'-most internucleotide linkage i.e. a single inverted nucleoside residue which may be abasic (the nucleobase is missing or has a hydroxyl group in place thereof). Various salts, mixed  
5 salts and free acid forms are also included.

Representative United States patents that teach the preparation of the above phosphorus-containing linkages include, but are not limited to, U.S.: 3,687,808; 4,469,863; 4,476,301; 5,023,243; 5,177,196; 5,188,897; 5,264,423; 5,276,019; 5,278,302; 5,286,717; 5,321,131; 5,399,676; 5,405,939; 5,453,496; 5,455,233;  
10 5,466,677; 5,476,925; 5,519,126; 5,536,821; 5,541,306; 5,550,111; 5,563,253; 5,571,799; 5,587,361; 5,194,599; 5,565,555; 5,527,899; 5,721,218; 5,672,697 and 5,625,050, certain of which are commonly owned with this application, and each of which is herein incorporated by reference.

In more preferred embodiments of the invention, oligomeric compounds have one  
15 or more phosphorothioate and/or heteroatom internucleoside linkages, in particular -CH<sub>2</sub>-NH-O-CH<sub>2</sub>-, -CH<sub>2</sub>-N(CH<sub>3</sub>)-O-CH<sub>2</sub>- [known as a methylene (methylimino) or MMI backbone], -CH<sub>2</sub>-O-N(CH<sub>3</sub>)-CH<sub>2</sub>-, -CH<sub>2</sub>-N(CH<sub>3</sub>)-N(CH<sub>3</sub>)-CH<sub>2</sub>- and -O-N(CH<sub>3</sub>)-CH<sub>2</sub>-CH<sub>2</sub>- [wherein the native phosphodiester internucleotide linkage is represented as -O-P(=O)(OH)-O-CH<sub>2</sub>-]. The MMI type internucleoside linkages are disclosed in the above  
20 referenced U.S. patent 5,489,677. Preferred amide internucleoside linkages are disclosed in the above referenced U.S. patent 5,602,240.

Preferred modified oligonucleotide backbones that do not include a phosphorus atom therein have backbones that are formed by short chain alkyl or cycloalkyl internucleoside linkages, mixed heteroatom and alkyl or cycloalkyl internucleoside  
25 linkages, or one or more short chain heteroatomic or heterocyclic internucleoside linkages. These include those having morpholino linkages (formed in part from the sugar portion of a nucleoside); siloxane backbones; sulfide, sulfoxide and sulfone backbones; formacetyl and thioformacetyl backbones; methylene formacetyl and thioformacetyl backbones; riboacetyl backbones; alkene containing backbones;  
30 sulfamate backbones; methyleneimino and methylenehydrazino backbones; sulfonate and sulfonamide backbones; amide backbones; and others having mixed N, O, S and CH<sub>2</sub> component parts.

Representative United States patents that teach the preparation of the above oligonucleosides include, but are not limited to, U.S.: 5,034,506; 5,166,315; 5,185,444;

5,214,134; 5,216,141; 5,235,033; 5,264,562; 5,264,564; 5,405,938; 5,434,257;  
5,466,677; 5,470,967; 5,489,677; 5,541,307; 5,561,225; 5,596,086; 5,602,240;  
5,610,289; 5,602,240; 5,608,046; 5,610,289; 5,618,704; 5,623,070; 5,663,312;  
5,633,360; 5,677,437; 5,792,608; 5,646,269 and 5,677,439, certain of which are  
5 commonly owned with this application, and each of which is herein incorporated by  
reference.

### Modified sugars

Oligomeric compounds of the invention may also contain one or more substituted  
10 sugar moieties. Preferred oligomeric compounds comprise a sugar substituent group  
selected from: OH; F; O-, S-, or N-alkyl; O-, S-, or N-alkenyl; O-, S- or N-alkynyl; or O-  
alkyl-O-alkyl, wherein the alkyl, alkenyl and alkynyl may be substituted or unsubstituted  
C<sub>1</sub> to C<sub>10</sub> alkyl or C<sub>2</sub> to C<sub>10</sub> alkenyl and alkynyl. Particularly preferred are O[(CH<sub>2</sub>)<sub>n</sub>O]<sub>m</sub>-  
CH<sub>3</sub>, O(CH<sub>2</sub>)<sub>n</sub>OCH<sub>3</sub>, O(CH<sub>2</sub>)<sub>n</sub>NH<sub>2</sub>, O(CH<sub>2</sub>)<sub>n</sub>CH<sub>3</sub>, O(CH<sub>2</sub>)<sub>n</sub>ONH<sub>2</sub>, and O(CH<sub>2</sub>)<sub>n</sub>ON-  
15 [(CH<sub>2</sub>)<sub>n</sub>CH<sub>3</sub>]<sub>2</sub>, where n and m are from 1 to about 10. Other preferred oligonucleotides  
comprise a sugar substituent group selected from: C<sub>1</sub> to C<sub>10</sub> lower alkyl, substituted  
lower alkyl, alkenyl, alkynyl, alkaryl, aralkyl, O-alkaryl or O-aralkyl, SH, SCH<sub>3</sub>, OCN,  
Cl, Br, CN, CF<sub>3</sub>, OCF<sub>3</sub>, SOCH<sub>3</sub>, SO<sub>2</sub>CH<sub>3</sub>, ONO<sub>2</sub>, NO<sub>2</sub>, N<sub>3</sub>, NH<sub>2</sub>, heterocycloalkyl,  
heterocycloalkaryl, aminoalkylamino, polyalkylamino, substituted silyl, an RNA  
20 cleaving group, a reporter group, an intercalator, a group for improving the  
pharmacokinetic properties of an oligonucleotide, or a group for improving the  
pharmacodynamic properties of an oligonucleotide, and other substituents having similar  
properties. A preferred modification includes 2'-methoxyethoxy (2'-O-CH<sub>2</sub>CH<sub>2</sub>OCH<sub>3</sub>,  
also known as 2'-O-(2-methoxyethyl) or 2'-MOE) (Martin *et al.*, *Helv. Chim. Acta*, **1995**,  
25 78, 486-504) i.e., an alkoxyalkoxy group. A further preferred modification includes 2'-  
dimethylaminoethoxy, i.e., a O(CH<sub>2</sub>)<sub>2</sub>ON(CH<sub>3</sub>)<sub>2</sub> group, also known as 2'-DMAOE, as  
described in examples hereinbelow, and 2'-dimethylaminoethoxyethoxy (also known in  
the art as 2'-O-dimethyl-amino-ethoxy-ethyl or 2'-DMAEOE), i.e., 2'-O-CH<sub>2</sub>OCH<sub>2</sub>-  
N(CH<sub>3</sub>)<sub>2</sub>.

30 Other preferred sugar substituent groups include methoxy (-O-CH<sub>3</sub>),  
aminopropoxy (-OCH<sub>2</sub>CH<sub>2</sub>CH<sub>2</sub>NH<sub>2</sub>), allyl (-CH<sub>2</sub>-CH=CH<sub>2</sub>), -O-allyl (-O-CH<sub>2</sub>-CH=CH<sub>2</sub>)  
and fluoro (F). 2'-Sugar substituent groups may be in the arabino (up) position or ribo  
(down) position. A preferred 2'-arabino modification is 2'-F. Similar modifications may  
also be made at other positions on the oligomeric compound, particularly the 3' position



or optionally,  $R_u$  and  $R_v$ , together form a phthalimido moiety with the nitrogen atom to which they are attached;

each  $R_w$  is, independently, substituted or unsubstituted  $C_1$ - $C_{10}$  alkyl, trifluoromethyl, cyanoethoxy, methoxy, ethoxy, t-butoxy, allyloxy, 9-fluorenylmethoxy, 2-(trimethylsilyl)-ethoxy, 2,2,2-trichloroethoxy, benzyloxy, butyryl, iso-butyryl, phenyl or aryl;

$R_k$  is hydrogen, a nitrogen protecting group or  $-R_x-R_y$ ;

$R_p$  is hydrogen, a nitrogen protecting group or  $-R_x-R_y$ ;

$R_x$  is a bond or a linking moiety;

10  $R_y$  is a chemical functional group, a conjugate group or a solid support medium;

each  $R_m$  and  $R_n$  is, independently, H, a nitrogen protecting group, substituted or unsubstituted  $C_1$ - $C_{10}$  alkyl, substituted or unsubstituted  $C_2$ - $C_{10}$  alkenyl, substituted or unsubstituted  $C_2$ - $C_{10}$  alkynyl, wherein the substituent groups are selected from hydroxyl, amino, alkoxy, carboxy, benzyl, phenyl, nitro, thiol, thioalkoxy, halogen, alkyl, aryl, alkenyl, alkynyl;  $NH_3^+$ ,  $N(R_u)(R_v)$ , guanidino and acyl where the acyl is an acid amide or an ester;

or  $R_m$  and  $R_n$ , together, are a nitrogen protecting group, are joined in a ring structure that optionally includes an additional heteroatom selected from N and O or are a chemical functional group;

20  $R_i$  is  $OR_z$ ,  $SR_z$ , or  $N(R_z)_2$ ;

each  $R_z$  is, independently, H,  $C_1$ - $C_8$  alkyl,  $C_1$ - $C_8$  haloalkyl,  $C(=NH)N(H)R_u$ ,  $C(=O)N(H)R_u$  or  $OC(=O)N(H)R_u$ ;

$R_f$ ,  $R_g$  and  $R_h$  comprise a ring system having from about 4 to about 7 carbon atoms or having from about 3 to about 6 carbon atoms and 1 or 2 heteroatoms wherein said heteroatoms are selected from oxygen, nitrogen and sulfur and wherein said ring system is aliphatic, unsaturated aliphatic, aromatic, or saturated or unsaturated heterocyclic;

25  $R_j$  is alkyl or haloalkyl having 1 to about 10 carbon atoms, alkenyl having 2 to about 10 carbon atoms, alkynyl having 2 to about 10 carbon atoms, aryl having 6 to about 14 carbon atoms,  $N(R_k)(R_m)$   $OR_k$ , halo,  $SR_k$  or CN;

$m_a$  is 1 to about 10;

each  $m_b$  is, independently, 0 or 1;

$m_c$  is 0 or an integer from 1 to 10;

$m_d$  is an integer from 1 to 10;



me is from 0, 1 or 2; and

provided that when mc is 0, md is greater than 1.

Representative substituents groups of Formula I are disclosed in United States Patent Application Serial No. 09/130,973, filed August 7, 1998, entitled "Capped  
5 2'-Oxyethoxy Oligonucleotides," hereby incorporated by reference in its entirety.

Representative cyclic substituent groups of Formula II are disclosed in United States Patent Application Serial No. 09/123,108, filed July 27, 1998, entitled "RNA Targeted 2'-Oligomeric compounds that are Conformationally Preorganized," hereby incorporated by reference in its entirety.

10 Particularly preferred sugar substituent groups include  $O[(CH_2)_nO]_mCH_3$ ,  $O(CH_2)_nOCH_3$ ,  $O(CH_2)_nNH_2$ ,  $O(CH_2)_nCH_3$ ,  $O(CH_2)_nONH_2$ , and  $O(CH_2)_nON[(CH_2)_nCH_3]_2$ , where n and m are from 1 to about 10.

Representative guanidino substituent groups that are shown in formula III and IV are disclosed in co-owned United States Patent Application 09/349,040, entitled  
15 "Functionalized Oligomers", filed July 7, 1999, hereby incorporated by reference in its entirety.

Representative acetamido substituent groups are disclosed in United States Patent 6,147,200 which is hereby incorporated by reference in its entirety.

Representative dimethylaminoethoxyethyl substituent groups are disclosed in  
20 International Patent Application PCT/US99/17895, entitled "2'-O-Dimethylaminoethoxyethyl-Oligomeric compounds", filed August 6, 1999, hereby incorporated by reference in its entirety.

#### **Modified Nucleobases/Naturally occurring nucleobases**

25 Oligomeric compounds may also include nucleobase (often referred to in the art simply as "base" or "heterocyclic base moiety") modifications or substitutions. As used herein, "unmodified" or "natural" nucleobases include the purine bases adenine (A) and guanine (G), and the pyrimidine bases thymine (T), cytosine (C) and uracil (U).

Modified nucleobases also referred herein as heterocyclic base moieties include other  
30 synthetic and natural nucleobases such as 5-methylcytosine (5-me-C), 5-hydroxymethyl cytosine, xanthine, hypoxanthine, 2-aminoadenine, 6-methyl and other alkyl derivatives of adenine and guanine, 2-propyl and other alkyl derivatives of adenine and guanine, 2-thiouracil, 2-thiothymine and 2-thiocytosine, 5-halouracil and cytosine, 5-propynyl (-

C≡C-CH<sub>3</sub>) uracil and cytosine and other alkynyl derivatives of pyrimidine bases, 6-azo uracil, cytosine and thymine, 5-uracil (pseudouracil), 4-thiouracil, 8-halo, 8-amino, 8-thiol, 8-thioalkyl, 8-hydroxyl and other 8-substituted adenines and guanines, 5-halo particularly 5-bromo, 5-trifluoromethyl and other 5-substituted uracils and cytosines, 7-methylguanine and 7-methyladenine, 2-F-adenine, 2-amino-adenine, 8-azaguanine and 8-azaadenine, 7-deazaguanine and 7-deazaadenine and 3-deazaguanine and 3-deazaadenine.

Heterocyclic base moieties may also include those in which the purine or pyrimidine base is replaced with other heterocycles, for example 7-deaza-adenine, 7-deazaguanosine, 2-aminopyridine and 2-pyridone. Further nucleobases include those disclosed in United States Patent No. 3,687,808, those disclosed in *The Concise Encyclopedia Of Polymer Science And Engineering*, pages 858-859, Kroschwitz, J.I., ed. John Wiley & Sons, 1990, those disclosed by Englisch et al., *Angewandte Chemie*, International Edition, 1991, 30, 613, and those disclosed by Sanghvi, Y.S., Chapter 15, *Antisense Research and Applications*, pages 289-302, Crooke, S.T. and Lebleu, B., ed., CRC Press, 1993. Certain of these nucleobases are particularly useful for increasing the binding affinity of the oligomeric compounds of the invention. These include 5-substituted pyrimidines, 6-azapyrimidines and N-2, N-6 and O-6 substituted purines, including 2-aminopropyladenine, 5-propynyluracil and 5-propynylcytosine. 5-methylcytosine substitutions have been shown to increase nucleic acid duplex stability by 0.6-1.2°C (Sanghvi, Y.S., Crooke, S.T. and Lebleu, B., eds., *Antisense Research and Applications*, CRC Press, Boca Raton, 1993, pp. 276-278) and are presently preferred base substitutions, even more particularly when combined with 2'-O-methoxyethyl sugar modifications.

Oligomeric compounds of the present invention can also include polycyclic heterocyclic compounds in place of one or more heterocyclic base moieties. A number of tricyclic heterocyclic compounds have been previously reported. These compounds are routinely used in antisense applications to increase the binding properties of the modified strand to a target strand. The most studied modifications are targeted to guanines hence they have been termed G-clamps or cytidine analogs. Many of these polycyclic heterocyclic compounds have the general formula:

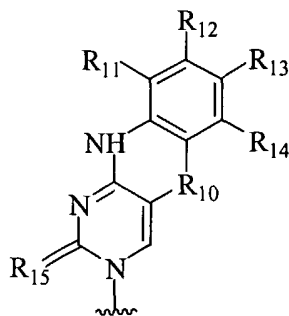

Representative cytosine analogs that make 3 hydrogen bonds with a guanosine in a second strand include 1,3-diazaphenoxazine-2-one ( $R_{10} = O$ ,  $R_{11} - R_{14} = H$ ) [Kurchavov, *et al.*, *Nucleosides and Nucleotides*, 1997, 16, 1837-1846], 1,3-diazaphenothiazine-2-one ( $R_{10} = S$ ,  $R_{11} - R_{14} = H$ ), [Lin, K.-Y.; Jones, R. J.; Matteucci, M. J. *Am. Chem. Soc.* 1995, 117, 3873-3874] and 6,7,8,9-tetrafluoro-1,3-diazaphenoxazine-2-one ( $R_{10} = O$ ,  $R_{11} - R_{14} = F$ ) [Wang, J.; Lin, K.-Y., Matteucci, M. *Tetrahedron Lett.* 1998, 39, 8385-8388].

Incorporated into oligonucleotides these base modifications were shown to hybridize with complementary guanine and the latter was also shown to hybridize with adenine and to enhance helical thermal stability by extended stacking interactions (also see U.S. Patent Application entitled "Modified Peptide Nucleic Acids" filed May 24, 2002, Serial number 10/155,920; and U.S. Patent Application entitled "Nuclease Resistant Chimeric Oligonucleotides" filed May 24, 2002, Serial number 10/013,295, both of which are commonly owned with this application and are herein incorporated by reference in their entirety).

Further helix-stabilizing properties have been observed when a cytosine analog/substitute has an aminoethoxy moiety attached to the rigid 1,3-diazaphenoxazine-2-one scaffold ( $R_{10} = O$ ,  $R_{11} = -O-(CH_2)_2-NH_2$ ,  $R_{12-14} = H$ ) [Lin, K.-Y.; Matteucci, M. J. *Am. Chem. Soc.* 1998, 120, 8531-8532]. Binding studies demonstrated that a single incorporation could enhance the binding affinity of a model oligonucleotide to its complementary target DNA or RNA with a  $\Delta T_m$  of up to 18° relative to 5-methyl cytosine ( $dC5^{me}$ ), which is the highest known affinity enhancement for a single modification, yet. On the other hand, the gain in helical stability does not compromise the specificity of the oligonucleotides. The  $T_m$  data indicate an even greater discrimination between the perfect match and mismatched sequences compared to  $dC5^{me}$ . It was suggested that the tethered amino group serves as an additional hydrogen bond donor to interact with the Hoogsteen face, namely the O6, of a complementary

guanine thereby forming 4 hydrogen bonds. This means that the increased affinity of G-clamp is mediated by the combination of extended base stacking and additional specific hydrogen bonding.

Further tricyclic heterocyclic compounds and methods of using them that are  
5 amenable to the present invention are disclosed in United States Patent Serial Number  
6,028,183, which issued on May 22, 2000, and United States Patent Serial Number  
6,007,992, which issued on December 28, 1999, the contents of both are commonly  
assigned with this application and are incorporated herein in their entirety.

The enhanced binding affinity of the phenoxazine derivatives together with their  
10 uncompromised sequence specificity makes them valuable nucleobase analogs for the  
development of more potent antisense-based drugs. In fact, promising data have been  
derived from in vitro experiments demonstrating that heptanucleotides containing  
phenoxazine substitutions are capable to activate RNaseH, enhance cellular uptake and  
exhibit an increased antisense activity [Lin, K-Y; Matteucci, M. J. Am. Chem. Soc.  
15 1998, 120, 8531-8532]. The activity enhancement was even more pronounced in case of  
G-clamp, as a single substitution was shown to significantly improve the in vitro potency  
of a 20mer 2'-deoxyphosphorothioate oligonucleotides [Flanagan, W. M.; Wolf, J.J.;  
Olson, P.; Grant, D.; Lin, K.-Y.; Wagner, R. W.; Matteucci, M. Proc. Natl. Acad. Sci.  
USA, 1999, 96, 3513-3518]. Nevertheless, to optimize oligonucleotide design and to  
20 better understand the impact of these heterocyclic modifications on the biological  
activity, it is important to evaluate their effect on the nuclease stability of the oligomers.

Further modified polycyclic heterocyclic compounds useful as heterocyclic  
bases are disclosed in but not limited to, the above noted U.S. 3,687,808, as well as U.S.:  
4,845,205; 5,130,302; 5,134,066; 5,175,273; 5,367,066; 5,432,272; 5,434,257;  
25 5,457,187; 5,459,255; 5,484,908; 5,502,177; 5,525,711; 5,552,540; 5,587,469;  
5,594,121, 5,596,091; 5,614,617; 5,645,985; 5,646,269; 5,750,692; 5,830,653;  
5,763,588; 6,005,096; and 5,681,941, and United States Patent Application Serial number  
09/996,292 filed November 28, 2001, certain of which are commonly owned with the  
instant application, and each of which is herein incorporated by reference.

30

### **Conjugates**

Oligomeric compounds used in the compositions of the present invention can also  
be modified to have one or more moieties or conjugates which enhance the activity,  
cellular distribution or cellular uptake of the resulting oligomeric compounds. In one

embodiment such modified oligomeric compounds are prepared by covalently attaching conjugate groups to functional groups such as hydroxyl or amino groups. Conjugate groups of the invention include intercalators, reporter molecules, polyamines, polyamides, polyethylene glycols, polyethers, groups that enhance the pharmacodynamic properties of oligomers, and groups that enhance the pharmacokinetic properties of oligomers. Typical conjugates groups include cholesterols, lipids, phospholipids, biotin, phenazine, folate, phenanthridine, anthraquinone, acridine, fluoresceins, rhodamines, coumarins, and dyes. Groups that enhance the pharmacodynamic properties, in the context of this invention, include groups that improve oligomer uptake, enhance oligomer resistance to degradation, and/or strengthen sequence-specific hybridization with RNA. Groups that enhance the pharmacokinetic properties, in the context of this invention, include groups that improve oligomer uptake, distribution, metabolism or excretion. Representative conjugate groups are disclosed in International Patent Application PCT/US92/09196, filed October 23, 1992 the entire disclosure of which is incorporated herein by reference. Conjugate moieties include but are not limited to lipid moieties such as a cholesterol moiety (Letsinger et al., *Proc. Natl. Acad. Sci. USA*, **1989**, *86*, 6553-6556), cholic acid (Manoharan et al., *Bioorg. Med. Chem. Let.*, **1994**, *4*, 1053-1060), a thioether, e.g., hexyl-S-tritylthiol (Manoharan et al., *Ann. N.Y. Acad. Sci.*, **1992**, *660*, 306-309; Manoharan et al., *Bioorg. Med. Chem. Let.*, **1993**, *3*, 2765-2770), a thiocholesterol (Oberhauser et al., *Nucl. Acids Res.*, **1992**, *20*, 533-538), an aliphatic chain, e.g., dodecandiol or undecyl residues (Saison-Behmoaras et al., *EMBO J.*, **1991**, *10*, 1111-1118; Kabanov et al., *FEBS Lett.*, **1990**, *259*, 327-330; Svinarchuk et al., *Biochimie*, **1993**, *75*, 49-54), a phospholipid, e.g., di-hexadecyl-rac-glycerol or triethylammonium 1,2-di-O-hexadecyl-rac-glycero-3-H-phosphonate (Manoharan et al., *Tetrahedron Lett.*, **1995**, *36*, 3651-3654; Shea et al., *Nucl. Acids Res.*, **1990**, *18*, 3777-3783), a polyamine or a polyethylene glycol chain (Manoharan et al., *Nucleosides & Nucleotides*, **1995**, *14*, 969-973), or adamantane acetic acid (Manoharan et al., *Tetrahedron Lett.*, **1995**, *36*, 3651-3654), a palmityl moiety (Mishra et al., *Biochim. Biophys. Acta*, **1995**, *1264*, 229-237), or an octadecylamine or hexylamino-carbonyloxycholesterol moiety (Crooke et al., *J. Pharmacol. Exp. Ther.*, **1996**, *277*, 923-937.

The oligomeric compounds of the invention may also be conjugated to active drug substances, for example, aspirin, warfarin, phenylbutazone, ibuprofen, suprofen, fenbufen, ketoprofen, (S)-(+)-pranoprofen, carprofen, dansylsarcosine, 2,3,5-triiodo-

benzoic acid, flufenamic acid, folic acid, a benzothiadiazide, chlorothiazide, a diazepam, indomethacin, a barbiturate, a cephalosporin, a sulfa drug, an antidiabetic, an antibacterial or an antibiotic. Oligonucleotide-drug conjugates and their preparation are described in United States Patent Application 09/334,130 (filed June 15, 1999) which is  
5 incorporated herein by reference in its entirety.

Representative United States patents that teach the preparation of such oligonucleotide conjugates include, but are not limited to, U.S.: 4,828,979; 4,948,882; 5,218,105; 5,525,465; 5,541,313; 5,545,730; 5,552,538; 5,578,717; 5,580,731; 5,580,731; 5,591,584; 5,109,124; 5,118,802; 5,138,045; 5,414,077; 5,486,603;  
10 5,512,439; 5,578,718; 5,608,046; 4,587,044; 4,605,735; 4,667,025; 4,762,779; 4,789,737; 4,824,941; 4,835,263; 4,876,335; 4,904,582; 4,958,013; 5,082,830; 5,112,963; 5,214,136; 5,082,830; 5,112,963; 5,214,136; 5,245,022; 5,254,469; 5,258,506; 5,262,536; 5,272,250; 5,292,873; 5,317,098; 5,371,241; 5,391,723; 5,416,203; 5,451,463; 5,510,475; 5,512,667; 5,514,785; 5,565,552; 5,567,810;  
15 5,574,142; 5,585,481; 5,587,371; 5,595,726; 5,597,696; 5,599,923; 5,599,928 and 5,688,941, certain of which are commonly owned with the instant application, and each of which is herein incorporated by reference.

### 3'-Endo Modifications

20 In one aspect of the present invention oligomeric compounds include nucleosides synthetically modified to induce a 3'-endo sugar conformation. A nucleoside can incorporate synthetic modifications of the heterocyclic base moiety, the sugar moiety or both to induce a desired 3'-endo sugar conformation. These modified nucleosides are used to mimic RNA like nucleosides so that particular properties of an oligomeric  
25 compound can be enhanced while maintaining the desirable 3'-endo conformational geometry. There is an apparent preference for an RNA type duplex (A form helix, predominantly 3'-endo) as a requirement of RNA interference which is supported in part by the fact that duplexes composed of 2'-deoxy-2'-F-nucleosides appear efficient in triggering RNAi response in the *C. elegans* system. Properties that are enhanced by  
30 using more stable 3'-endo nucleosides include but aren't limited to modulation of pharmacokinetic properties through modification of protein binding, protein off-rate, absorption and clearance; modulation of nuclease stability as well as chemical stability; modulation of the binding affinity and specificity of the oligomer (affinity and specificity for enzymes as well as for complementary sequences); and increasing efficacy of RNA

cleavage. The present invention provides oligomeric compounds having one or more nucleosides modified in such a way as to favor a C3'-endo type conformation.

**Scheme 1**



5

C2'-endo/Southern

C3'-endo/Northern

Nucleoside conformation is influenced by various factors including substitution at the 2', 3' or 4'-positions of the pentofuranosyl sugar. Electronegative substituents generally prefer the axial positions, while sterically demanding substituents generally prefer the equatorial positions (Principles of Nucleic Acid Structure, Wolfgang Sanger, 1984, Springer-Verlag.) Modification of the 2' position to favor the 3'-endo conformation can be achieved while maintaining the 2'-OH as a recognition element, as exemplified in Example 35, below (Gallo et al., Tetrahedron (2001), 57, 5707-5713. Harry-O'kuru et al., J. Org. Chem., (1997), 62(6), 1754-1759 and Tang et al., J. Org. Chem. (1999), 64, 747-754.) Alternatively, preference for the 3'-endo conformation can be achieved by deletion of the 2'-OH as exemplified by 2'-deoxy-2'-F-nucleosides (Kawasaki et al., J. Med. Chem. (1993), 36, 831-841), which adopts the 3'-endo conformation positioning the electronegative fluorine atom in the axial position. Other modifications of the ribose ring, for example substitution at the 4'-position to give 4'-F modified nucleosides (Guillerm et al., Bioorganic and Medicinal Chemistry Letters (1995), 5, 1455-1460 and Owen et al., J. Org. Chem. (1976), 41, 3010-3017), or for example modification to yield methanocarba nucleoside analogs (Jacobson et al., J. Med. Chem. Lett. (2000), 43, 2196-2203 and Lee et al., Bioorganic and Medicinal Chemistry Letters (2001), 11, 1333-1337) also induce preference for the 3'-endo conformation. Some modifications actually lock the conformational geometry by formation of a bicyclic sugar moiety e.g. locked nucleic acid (LNA, Singh et al, Chem. Commun. (1998), 4, 455-456), and ethylene bridged nucleic acids (ENA, Morita et al, Bioorganic & Medicinal Chemistry Letters (2002), 12, 73-76.)

25

Examples of modified nucleosides amenable to the present invention are shown below in Table I. These examples are meant to be representative and not exhaustive.

Table I

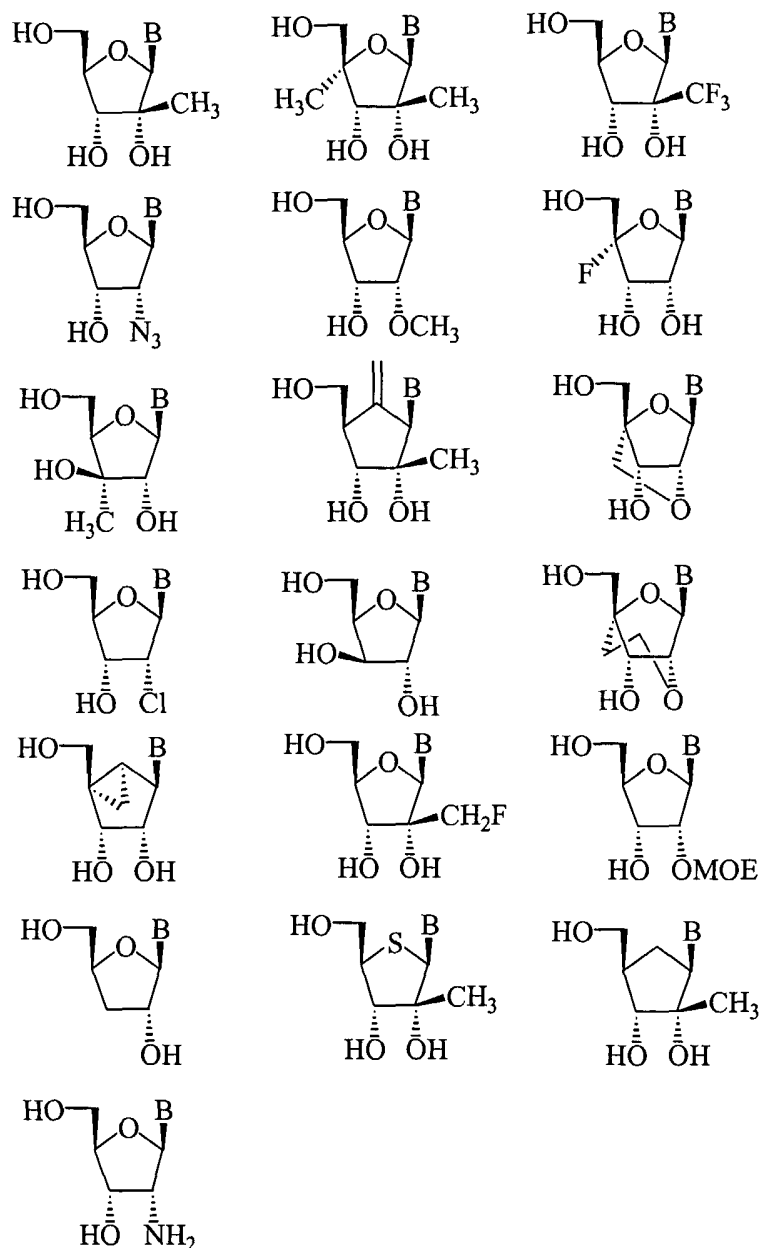

- 5            The preferred conformation of modified nucleosides and their oligomers can be estimated by various methods such as molecular dynamics calculations, nuclear magnetic resonance spectroscopy and CD measurements. Hence, modifications predicted to induce RNA like conformations, A-form duplex geometry in an oligomeric context, are selected for use in one or more of the oligomeric compounds of the present invention.
- 10          The synthesis of numerous of the modified nucleosides amenable to the present



invention are known in the art (see for example, Chemistry of Nucleosides and Nucleotides Vol 1-3, ed. Leroy B. Townsend, 1988, Plenum press., and the examples section below.) Nucleosides known to be inhibitors/substrates for RNA dependent RNA polymerases (for example HCV NS5B

5           In one aspect, the present invention is directed to oligomeric compounds that are prepared having enhanced properties compared to native RNA against nucleic acid targets. A target is identified and an oligomeric compound is selected having an effective length and sequence that is complementary to a portion of the target sequence. Each nucleoside of the selected sequence is scrutinized for possible enhancing  
10 modifications. A preferred modification would be the replacement of one or more RNA nucleosides with nucleosides that have the same 3'-endo conformational geometry. Such modifications can enhance chemical and nuclease stability relative to native RNA while at the same time being much cheaper and easier to synthesize and/or incorporate into an oligomeric compound. The selected sequence can be further divided into regions and the  
15 nucleosides of each region evaluated for enhancing modifications that can be the result of a chimeric configuration. Consideration is also given to the termini (e.g. 5' and 3'-termini) as there are often advantageous modifications that can be made to one or more of the terminal monomeric subunits. In one aspect of the invention, desired properties and or activity of oligomeric compounds are enhanced by the inclusion of a 5'-phosphate  
20 or modified phosphate moiety.

The terms used to describe the conformational geometry of homoduplex nucleic acids are "A Form" for RNA and "B Form" for DNA. The respective conformational geometry for RNA and DNA duplexes was determined from X-ray diffraction analysis of nucleic acid fibers (Arnott and Hukins, *Biochem. Biophys. Res. Comm.*, **1970**, *47*,  
25 1504.) In general, RNA:RNA duplexes are more stable and have higher melting temperatures (T<sub>m</sub>'s) than DNA:DNA duplexes (Sanger et al., *Principles of Nucleic Acid Structure*, 1984, Springer-Verlag; New York, NY.; Lesnik et al., *Biochemistry*, 1995, *34*, 10807-10815; Conte et al., *Nucleic Acids Res.*, 1997, *25*, 2627-2634). The increased stability of RNA has been attributed to several structural features, most notably the  
30 improved base stacking interactions that result from an A-form geometry (Searle et al., *Nucleic Acids Res.*, 1993, *21*, 2051-2056). The presence of the 2' hydroxyl in RNA biases the sugar toward a C3' endo pucker, i.e., also designated as Northern pucker, which causes the duplex to favor the A-form geometry. In addition, the 2' hydroxyl groups of RNA can form a network of water mediated hydrogen bonds that help stabilize

the RNA duplex (Egli et al., *Biochemistry*, 1996, 35, 8489-8494). On the other hand, deoxy nucleic acids prefer a C2' endo sugar pucker, i.e., also known as Southern pucker, which is thought to impart a less stable B-form geometry (Sanger, W. (1984) *Principles of Nucleic Acid Structure*, Springer-Verlag, New York, NY). As used herein, B-form  
5 geometry is inclusive of both C2'-endo pucker and O4'-endo pucker. This is consistent with Berger, et. al., *Nucleic Acids Research*, 1998, 26, 2473-2480, who pointed out that in considering the furanose conformations which give rise to B-form duplexes consideration should also be given to a O4'-endo pucker contribution.

DNA:RNA hybrid duplexes, however, are usually less stable than pure  
10 RNA:RNA duplexes, and depending on their sequence may be either more or less stable than DNA:DNA duplexes (Searle et al., *Nucleic Acids Res.*, 1993, 21, 2051-2056). The structure of a hybrid duplex is intermediate between A- and B-form geometries, which may result in poor stacking interactions (Lane et al., *Eur. J. Biochem.*, 1993, 215, 297-306; Fedoroff et al., *J. Mol. Biol.*, 1993, 233, 509-523; Gonzalez et al., *Biochemistry*,  
15 1995, 34, 4969-4982; Horton et al., *J. Mol. Biol.*, 1996, 264, 521-533). The stability of the duplex formed between a target RNA and a synthetic sequence is central to therapies such as but not limited to antisense and RNA interference as these mechanisms require the binding of a synthetic strand of oligomeric compound to an RNA target strand. In the case of antisense, effective inhibition of the mRNA requires that the antisense DNA  
20 have a very high binding affinity with the mRNA. Otherwise the desired interaction between the synthetic strand and target mRNA strand will occur infrequently, resulting in decreased efficacy.

One routinely used method of modifying the sugar puckering is the substitution of the sugar at the 2'-position with a substituent group that influences the sugar geometry.  
25 The influence on ring conformation is dependant on the nature of the substituent at the 2'-position. A number of different substituents have been studied to determine their sugar puckering effect. For example, 2'-halogens have been studied showing that the 2'-fluoro derivative exhibits the largest population (65%) of the C3'-endo form, and the 2'-iodo exhibits the lowest population (7%). The populations of adenosine (2'-OH)  
30 versus deoxyadenosine (2'-H) are 36% and 19%, respectively. Furthermore, the effect of the 2'-fluoro group of adenosine dimers (2'-deoxy-2'-fluoroadenosine - 2'-deoxy-2'-fluoro-adenosine) is further correlated to the stabilization of the stacked conformation.

As expected, the relative duplex stability can be enhanced by replacement of 2'-OH groups with 2'-F groups thereby increasing the C3'-endo population. It is assumed that the highly polar nature of the 2'-F bond and the extreme preference for C3'-endo pucker may stabilize the stacked conformation in an A-form duplex. Data from UV  
5 hypochromicity, circular dichroism, and <sup>1</sup>H NMR also indicate that the degree of stacking decreases as the electronegativity of the halo substituent decreases. Furthermore, steric bulk at the 2'-position of the sugar moiety is better accommodated in an A-form duplex than a B-form duplex. Thus, a 2'-substituent on the 3'-terminus of a dinucleoside monophosphate is thought to exert a number of effects on the stacking  
10 conformation: steric repulsion, furanose pucker preference, electrostatic repulsion, hydrophobic attraction, and hydrogen bonding capabilities. These substituent effects are thought to be determined by the molecular size, electronegativity, and hydrophobicity of the substituent. Melting temperatures of complementary strands is also increased with the 2'-substituted adenosine diphosphates. It is not clear whether the 3'-endo preference  
15 of the conformation or the presence of the substituent is responsible for the increased binding. However, greater overlap of adjacent bases (stacking) can be achieved with the 3'-endo conformation.

One synthetic 2'-modification that imparts increased nuclease resistance and a very high binding affinity to nucleotides is the 2-methoxyethoxy (2'-MOE, 2'-  
20 OCH<sub>2</sub>CH<sub>2</sub>OCH<sub>3</sub>) side chain (Baker *et al.*, *J. Biol. Chem.*, **1997**, *272*, 11944-12000). One of the immediate advantages of the 2'-MOE substitution is the improvement in binding affinity, which is greater than many similar 2' modifications such as *O*-methyl, *O*-propyl, and *O*-aminopropyl. Oligonucleotides having the 2'-*O*-methoxyethyl substituent also have been shown to be antisense inhibitors of gene expression with promising features  
25 for *in vivo* use (Martin, P., *Helv. Chim. Acta*, **1995**, *78*, 486-504; Altmann *et al.*, *Chimia*, **1996**, *50*, 168-176; Altmann *et al.*, *Biochem. Soc. Trans.*, **1996**, *24*, 630-637; and Altmann *et al.*, *Nucleosides Nucleotides*, **1997**, *16*, 917-926). Relative to DNA, the oligonucleotides having the 2'-MOE modification displayed improved RNA affinity and higher nuclease resistance. Chimeric oligonucleotides having 2'-MOE substituents in the  
30 wing nucleosides and an internal region of deoxy-phosphorothioate nucleotides (also termed a gapped oligonucleotide or gapmer) have shown effective reduction in the growth of tumors in animal models at low doses. 2'-MOE substituted oligonucleotides have also shown outstanding promise as antisense agents in several disease states. One

such MOE substituted oligonucleotide is presently being investigated in clinical trials for the treatment of CMV retinitis.

To better understand the higher RNA affinity of 2'-*O*-methoxyethyl substituted RNA and to examine the conformational properties of the 2'-*O*-methoxyethyl substituent, two dodecamer oligonucleotides were synthesized having SEQ ID NO: 10 (CGC GAA UUC GCG) and SEQ ID NO: 11 (GCG CUU AAG CGC). These self-complementary strands have every 2'-position modified with a 2'-*O*-methoxyethyl. The duplex was crystallized at a resolution of 1.7 Ångstrom and the crystal structure was determined. The conditions used for the crystallization were 2 mM oligonucleotide, 50 mM Na HEPES pH 6.2-7.5, 10.50 mM MgCl<sub>2</sub>, 15% PEG 400. The crystal data showed: space group C2, cell constants  $a=41.2$  Å,  $b=34.4$  Å,  $c=46.6$  Å,  $\beta=92.4^\circ$ . The resolution was 1.7 Å at -170°C. The current  $R$ -factor was 20% ( $R_{\text{free}}$  26%).

This crystal structure is believed to be the first crystal structure of a fully modified RNA oligonucleotide analogue. The duplex adopts an overall A-form conformation and all modified sugars display C3'-*endo* pucker. In most of the 2'-*O*-substituents, the torsion angle around the A'-B' bond, as depicted in Structure II below, of the ethylene glycol linker has a *gauche* conformation. For 2'-*O*-MOE, A' and B' of Structure II below are methylene moieties of the ethyl portion of the MOE and R' is the methoxy portion.

20

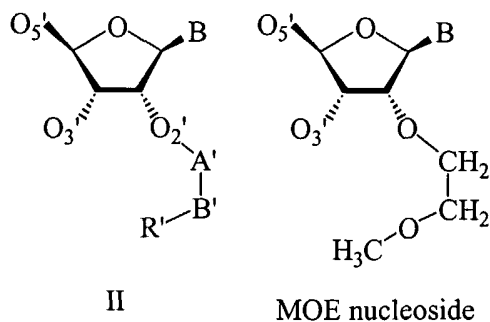

In the crystal, the 2'-*O*-MOE RNA duplex adopts a general orientation such that the crystallographic 2-fold rotation axis does not coincide with the molecular 2-fold rotation axis. The duplex adopts the expected A-type geometry and all of the 24 2'-*O*-MOE substituents were visible in the electron density maps at full resolution. The electron density maps as well as the temperature factors of substituent atoms indicate flexibility of the 2'-*O*-MOE substituent in some cases.

25

Most of the 2'-O-MOE substituents display a *gauche* conformation around the C-C bond of the ethyl linker. However, in two cases, a *trans* conformation around the C-C bond is observed. The lattice interactions in the crystal include packing of duplexes against each other via their minor grooves. Therefore, for some residues, the conformation of the 2'-O-substituent is affected by contacts to an adjacent duplex. In general, variations in the conformation of the substituents (e.g.  $g^+$  or  $g^-$  around the C-C bonds) create a range of interactions between substituents, both inter-strand, across the minor groove, and intra-strand. At one location, atoms of substituents from two residues are in van der Waals contact across the minor groove. Similarly, a close contact occurs between atoms of substituents from two adjacent intra-strand residues.

Previously determined crystal structures of A-DNA duplexes were for those that incorporated isolated 2'-O-methyl T residues. In the crystal structure noted above for the 2'-O-MOE substituents, a conserved hydration pattern has been observed for the 2'-O-MOE residues. A single water molecule is seen located between O2', O3' and the methoxy oxygen atom of the substituent, forming contacts to all three of between 2.9 and 3.4 Å. In addition, oxygen atoms of substituents are involved in several other hydrogen bonding contacts. For example, the methoxy oxygen atom of a particular 2'-O-substituent forms a hydrogen bond to N3 of an adenosine from the opposite strand via a bridging water molecule.

In several cases a water molecule is trapped between the oxygen atoms O2', O3' and OC' of modified nucleosides. 2'-O-MOE substituents with *trans* conformation around the C-C bond of the ethylene glycol linker are associated with close contacts between OC' and N2 of a guanosine from the opposite strand, and, water-mediated, between OC' and N3(G). When combined with the available thermodynamic data for duplexes containing 2'-O-MOE modified strands, this crystal structure allows for further detailed structure-stability analysis of other modifications.

In extending the crystallographic structure studies, molecular modeling experiments were performed to study further enhanced binding affinity of oligonucleotides having 2'-O-modifications. The computer simulations were conducted on compounds of SEQ ID NO: 10, above, having 2'-O-modifications located at each of the nucleosides of the oligonucleotide. The simulations were performed with the oligonucleotide in aqueous solution using the AMBER force field method (Cornell *et al.*, *J. Am. Chem. Soc.*, **1995**, *117*, 5179-5197)(modeling software package from UCSF, San

Francisco, CA). The calculations were performed on an Indigo2 SGI machine (Silicon Graphics, Mountain View, CA).

Further 2'-O-modifications that will have a 3'-endo sugar influence include those having a ring structure that incorporates a two atom portion corresponding to the A' and B' atoms of Structure II. The ring structure is attached at the 2' position of a sugar moiety of one or more nucleosides that are incorporated into an oligonucleotide. The 2'-oxygen of the nucleoside links to a carbon atom corresponding to the A' atom of Structure II. These ring structures can be aliphatic, unsaturated aliphatic, aromatic or heterocyclic. A further atom of the ring (corresponding to the B' atom of Structure II), bears a further oxygen atom, or a sulfur or nitrogen atom. This oxygen, sulfur or nitrogen atom is bonded to one or more hydrogen atoms, alkyl moieties, or haloalkyl moieties, or is part of a further chemical moiety such as a ureido, carbamate, amide or amidine moiety. The remainder of the ring structure restricts rotation about the bond joining these two ring atoms. This assists in positioning the "further oxygen, sulfur or nitrogen atom" (part of the R position as described above) such that the further atom can be located in close proximity to the 3'-oxygen atom (O3') of the nucleoside.

Another preferred 2'-sugar substituent group that gives a 3'-endo sugar conformational geometry is the 2'-OMe group. 2'-Substitution of guanosine, cytidine, and uridine dinucleoside phosphates with the 2'-OMe group showed enhanced stacking effects with respect to the corresponding native (2'-OH) species leading to the conclusion that the sugar is adopting a C3'-endo conformation. In this case, it is believed that the hydrophobic attractive forces of the methyl group tend to overcome the destabilizing effects of its steric bulk.

The ability of oligonucleotides to bind to their complementary target strands is compared by determining the melting temperature ( $T_m$ ) of the hybridization complex of the oligonucleotide and its complementary strand. The melting temperature ( $T_m$ ), a characteristic physical property of double helices, denotes the temperature (in degrees centigrade) at which 50% helical (hybridized) versus coil (unhybridized) forms are present.  $T_m$  is measured by using the UV spectrum to determine the formation and breakdown (melting) of the hybridization complex. Base stacking, which occurs during hybridization, is accompanied by a reduction in UV absorption (hypochromicity). Consequently, a reduction in UV absorption indicates a higher  $T_m$ . The higher the  $T_m$ , the greater the strength of the bonds between the strands.

Freier and Altmann, *Nucleic Acids Research*, (1997) 25:4429-4443, have previously published a study on the influence of structural modifications of oligonucleotides on the stability of their duplexes with target RNA. In this study, the authors reviewed a series of oligonucleotides containing more than 200 different  
5 modifications that had been synthesized and assessed for their hybridization affinity and  $T_m$ . Sugar modifications studied included substitutions on the 2'-position of the sugar, 3'-substitution, replacement of the 4'-oxygen, the use of bicyclic sugars, and four member ring replacements. Several nucleobase modifications were also studied including substitutions at the 5, or 6 position of thymine, modifications of pyrimidine  
10 heterocycle and modifications of the purine heterocycle. Modified internucleoside linkages were also studied including neutral, phosphorus and non-phosphorus containing internucleoside linkages.

Increasing the percentage of C3'-endo sugars in a modified oligonucleotide targeted to an RNA target strand should preorganize this strand for binding to RNA. Of  
15 the several sugar modifications that have been reported and studied in the literature, the incorporation of electronegative substituents such as 2'-fluoro or 2'-alkoxy shift the sugar conformation towards the 3' endo (northern) pucker conformation. This preorganizes an oligonucleotide that incorporates such modifications to have an A-form conformational geometry. This A-form conformation results in increased binding affinity of the  
20 oligonucleotide to a target RNA strand.

Molecular modeling experiments were performed to study further enhanced binding affinity of oligonucleotides having 2'-O-modifications. Computer simulations were conducted on compounds having SEQ ID NO: 10, r(CGC GAA UUC GCG), having 2'-O-modifications of the invention located at each of the nucleoside of the  
25 oligonucleotide. The simulations were performed with the oligonucleotide in aqueous solution using the AMBER force field method (Cornell *et al.*, *J. Am. Chem. Soc.*, 1995, 117, 5179-5197)(modeling software package from UCSF, San Francisco, CA). The calculations were performed on an Indigo2 SGI machine (Silicon Graphics, Mountain View, CA).

30 In addition, for 2'-substituents containing an ethylene glycol motif, a *gauche* interaction between the oxygen atoms around the O-C-C-O torsion of the side chain may have a stabilizing effect on the duplex (Freier *ibid.*). Such *gauche* interactions have been observed experimentally for a number of years (Wolfe *et al.*, *Acc. Chem. Res.*, 1972, 5, 102; Abe *et al.*, *J. Am. Chem. Soc.*, 1976, 98, 468). This *gauche* effect may result in a

configuration of the side chain that is favorable for duplex formation. The exact nature of this stabilizing configuration has not yet been explained. While we do not want to be bound by theory, it may be that holding the O-C-C-O torsion in a single *gauche* configuration, rather than a more random distribution seen in an alkyl side chain, provides an entropic advantage for duplex formation.

Representative 2'-substituent groups amenable to the present invention that give A-form conformational properties (3'-endo) to the resultant duplexes include 2'-O-alkyl, 2'-O-substituted alkyl and 2'-fluoro substituent groups. Preferred for the substituent groups are various alkyl and aryl ethers and thioethers, amines and monoalkyl and dialkyl substituted amines. It is further intended that multiple modifications can be made to one or more of the oligomeric compounds of the invention at multiple sites of one or more monomeric subunits (nucleosides are preferred) and or internucleoside linkages to enhance properties such as but not limited to activity in a selected application. Tables I through VII list nucleoside and internucleotide linkage modifications/replacements that have been shown to give a positive  $\Delta T_m$  per modification when the modification/replacement was made to a DNA strand that was hybridized to an RNA complement.



Table I

Modified DNA strand having 2'-substituent groups that gave an overall increase in T<sub>m</sub> against an RNA complement:

	<u>Positive ΔT<sub>m</sub>/mod</u>
5	2'-OH
	2'-O-C <sub>1</sub> -C <sub>4</sub> alkyl
	2'-O-(CH <sub>2</sub> ) <sub>2</sub> CH <sub>3</sub>
	2'-O-CH <sub>2</sub> CH=CH <sub>2</sub>
10	2'-F
	2'-O-(CH <sub>2</sub> ) <sub>2</sub> -O-CH <sub>3</sub>
	2'-[O-(CH <sub>2</sub> ) <sub>2</sub> ] <sub>2</sub> -O-CH <sub>3</sub>
	2'-[O-(CH <sub>2</sub> ) <sub>2</sub> ] <sub>3</sub> -O-CH <sub>3</sub>
	2'-[O-(CH <sub>2</sub> ) <sub>2</sub> ] <sub>4</sub> -O-CH <sub>3</sub>
15	2'-[O-(CH <sub>2</sub> ) <sub>2</sub> ] <sub>3</sub> -O-(CH <sub>2</sub> ) <sub>8</sub> CH <sub>3</sub>
	2'-O-(CH <sub>2</sub> ) <sub>2</sub> CF <sub>3</sub>
	2'-O-(CH <sub>2</sub> ) <sub>2</sub> OH
	2'-O-(CH <sub>2</sub> ) <sub>2</sub> F
	2'-O-CH <sub>2</sub> CH(CH <sub>3</sub> )F
20	2'-O-CH <sub>2</sub> CH(CH <sub>2</sub> OH)OH
	2'-O-CH <sub>2</sub> CH(CH <sub>2</sub> OCH <sub>3</sub> )OCH <sub>3</sub>
	2'-O-CH <sub>2</sub> CH(CH <sub>3</sub> )OCH <sub>3</sub>
	2'-O-CH <sub>2</sub> -C <sub>14</sub> H <sub>7</sub> O <sub>2</sub> (-C <sub>14</sub> H <sub>7</sub> O <sub>2</sub> = Anthraquinone)
25	2'-O-(CH <sub>2</sub> ) <sub>3</sub> -NH <sub>2</sub> *
	2'-O-(CH <sub>2</sub> ) <sub>4</sub> -NH <sub>2</sub> *

\* These modifications can increase the T<sub>m</sub> of oligonucleotides but can also decrease the T<sub>m</sub> depending on positioning and number (motif dependent).

Table II

Modified DNA strand having modified sugar ring (see structure x) that gave an overall increase in  $T_m$  against an RNA complement:

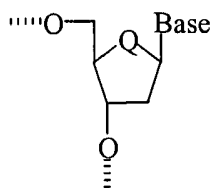

5

Positive  $\Delta T_m/mod$ 

Q            -S-  
              -CH<sub>2</sub>-

Note: In general ring oxygen substitution with sulfur or methylene had only a minor effect on  $T_m$  for the specific motifs studied. Substitution at the 2'-position with groups shown to stabilize the duplex were destabilizing when CH<sub>2</sub> replaced the ring O. This is thought to be due to the necessary gauche interaction between the ring O with particular 2'-substituents (for example -O-CH<sub>3</sub> and -(O-CH<sub>2</sub>CH<sub>2</sub>)<sub>3</sub>-O-CH<sub>3</sub>).

15

Modified DNA strand having modified sugar ring that give an overall increase in  $T_m$  against an RNA complement:

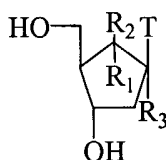
Positive  $\Delta T_m/mod$ 

-C(H)R<sub>1</sub> effects            OH  
20 (R<sub>2</sub>, R<sub>3</sub> both = H)        CH<sub>3</sub>\*  
  CH<sub>2</sub>OH\*  
  OCH<sub>3</sub>\*

\* These modifications can increase the  $T_m$  of oligonucleotides but can also decrease the  $T_m$  depending on positioning and number (motif dependent).

Table IV

Modified DNA strand having bicyclic substitute sugar modifications that give an overall increase in  $T_m$  against an RNA complement:

5	Formula	<u>Positive <math>\Delta T_m</math>/mod</u>
	I	+
	II	+

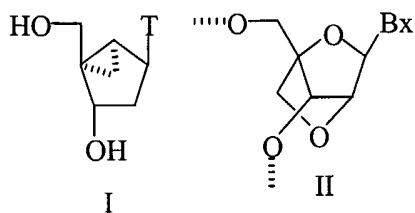
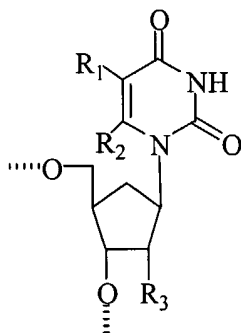

Table V

Modified DNA strand having modified heterocyclic base moieties that give an overall increase in  $T_m$  against an RNA complement:

5	<u>Modification/Formula</u>	<u>Positive <math>\Delta T_m</math>/mod</u>
	Heterocyclic base modifications	2-thioT 2'-O-methylpseudoU 7-halo-7-deaza purines 7-propyne-7-deaza purines
10		2-aminoA(2,6-diaminopurine)

15	<u>Modification/Formula</u>	<u>Positive <math>\Delta T_m</math>/mod</u>
----	-----------------------------	---



( $R_2, R_3=H$ ),  $R_1=$

Br  
C/C- $CH_3$   
( $CH_2$ ) $_3$ NH $_2$   
 $CH_3$

Motiffs-disubstitution

$R_1= C/C-CH_3, R_2=H, R_3=$

F

20

$R_1= C/C-CH_3, R_2=H$

$R_3= O-(CH_2)_2-O-CH_3$

$R_1= O-CH_3, R_2=H,$

$R_3= O-(CH_2)_2-O-CH_3^*$

\* This modification can increase the  $T_m$  of oligonucleotides but can also decrease the  $T_m$  depending on positioning and number (motiff dependant).

25

Substitution at  $R_1$  can be stabilizing, substitution at  $R_2$  is generally greatly destabilizing (unable to form anti conformation), motiffs with stabilizing 5 and 2'-substituent groups are generally additive e.g. increase stability.

Substitution of the O4 and O2 positions of 2'-O-methyl uridine was greatly duplex destabilizing as these modifications remove hydrogen binding sites that would be an expected result. 6-Aza T also showed extreme destabilization as this substitution reduces the pK<sub>a</sub> and shifts the nucleoside toward the enol tautomer resulting in reduced hydrogen bonding.

Table VI

**DNA strand having at least one modified phosphorus containing internucleoside linkage and the effect on the T<sub>m</sub> against an RNA complement:**

10	<b>ΔT<sub>m</sub>/mod +</b>	<b>ΔT<sub>m</sub>/mod -</b> phosphorothioate <sup>1</sup> phosphoramidate <sup>1</sup> methyl phosphonates <sup>1</sup> ( <sup>1</sup> one of the non-bridging oxygen atoms replaced with S, N(H)R or -CH <sub>3</sub> )
15	phosphoramidate (the 3'-bridging atom replaced with an N(H)R group, stabilization effect enhanced when also have 2'-F)	

20

Table VII

**DNA strand having at least one non-phosphorus containing internucleoside linkage and the effect on the T<sub>m</sub> against an RNA complement:**

25	<b>Positive ΔT<sub>m</sub>/mod</b> -CH <sub>2</sub> C(=O)NHCH <sub>2</sub> -* -CH <sub>2</sub> C(=O)N(CH <sub>3</sub> )CH <sub>2</sub> -* -CH <sub>2</sub> C(=O)N(CH <sub>2</sub> CH <sub>2</sub> CH <sub>3</sub> )CH <sub>2</sub> -* -CH <sub>2</sub> C(=O)N(H)CH <sub>2</sub> - (motiff with 5'-propyne on T's)
30	-CH <sub>2</sub> N(H)C(=O)CH <sub>2</sub> -*  -CH <sub>2</sub> N(CH <sub>3</sub> )OCH <sub>2</sub> -* -CH <sub>2</sub> N(CH <sub>3</sub> )N(CH <sub>3</sub> )CH <sub>2</sub> -*

\* This modification can increase the  $T_m$  of oligonucleotides but can also decrease the  $T_m$  depending on positioning and number (motif dependant).

Notes: In general carbon chain internucleotide linkages were destabilizing to duplex formation. This destabilization was not as severe when double and triple bonds were utilized. The use of glycol and flexible ether linkages were also destabilizing.

Preferred ring structures of the invention for inclusion as a 2'-O modification include cyclohexyl, cyclopentyl and phenyl rings as well as heterocyclic rings having spacial footprints similar to cyclohexyl, cyclopentyl and phenyl rings. Particularly preferred 2'-O-substituent groups of the invention are listed below including an abbreviation for each:

2'-O-(trans 2-methoxy cyclohexyl)	-- 2'-O-(TMCHL)
2'-O-(trans 2-methoxy cyclopentyl)	-- 2'-O-(TMCPL)
2'-O-(trans 2-ureido cyclohexyl)	-- 2'-O-(TUCHL)
2'-O-(trans 2-methoxyphenyl)	-- 2'-O-(2MP)

Structural details for duplexes incorporating such 2'-O-substituents were analyzed using the described AMBER force field program on the Indigo2 SGI machine. The simulated structure maintained a stable A-form geometry throughout the duration of the simulation. The presence of the 2' substitutions locked the sugars in the C3'-endo conformation.

The simulation for the TMCHL modification revealed that the 2'-O-(TMCHL) side chains have a direct interaction with water molecules solvating the duplex. The oxygen atoms in the 2'-O-(TMCHL) side chain are capable of forming a water-mediated interaction with the 3' oxygen of the phosphate backbone. The presence of the two oxygen atoms in the 2'-O-(TMCHL) side chain gives rise to favorable gauche interactions. The barrier for rotation around the O-C-C-O torsion is made even larger by this novel modification. The preferential preorganization in an A-type geometry increases the binding affinity of the 2'-O-(TMCHL) to the target RNA. The locked side chain conformation in the 2'-O-(TMCHL) group created a more favorable pocket for binding water molecules. The presence of these water molecules played a key role in holding the side chains in the preferable gauche conformation. While not wishing to be bound by theory, the bulk of the substituent, the diequatorial orientation of the substituents in the cyclohexane ring, the water of hydration and the potential for trapping of metal ions in the conformation generated will additionally contribute to improved

binding affinity and nuclease resistance of oligonucleotides incorporating nucleosides having this 2'-O-modification.

As described for the TMCHL modification above, identical computer simulations of the 2'-O-(TMCPL), the 2'-O-(2MP) and 2'-O-(TUCHL) modified oligonucleotides in aqueous solution also illustrate that stable A-form geometry will be maintained throughout the duration of the simulation. The presence of the 2' substitution will lock the sugars in the C3'-endo conformation and the side chains will have direct interaction with water molecules solvating the duplex. The oxygen atoms in the respective side chains are capable of forming a water-mediated interaction with the 3' oxygen of the phosphate backbone. The presence of the two oxygen atoms in the respective side chains give rise to the favorable gauche interactions. The barrier for rotation around the respective O-C-C-O torsions will be made even larger by respective modification. The preferential preorganization in A-type geometry will increase the binding affinity of the respective 2'-O-modified oligonucleotides to the target RNA. The locked side chain conformation in the respective modifications will create a more favorable pocket for binding water molecules. The presence of these water molecules plays a key role in holding the side chains in the preferable gauche conformation. The bulk of the substituent, the diequatorial orientation of the substituents in their respective rings, the water of hydration and the potential trapping of metal ions in the conformation generated will all contribute to improved binding affinity and nuclease resistance of oligonucleotides incorporating nucleosides having these respective 2'-O-modification.

Ribose conformations in C2'-modified nucleosides containing S-methyl groups were examined. To understand the influence of 2'-O-methyl and 2'-S-methyl groups on the conformation of nucleosides, we evaluated the relative energies of the 2'-O- and 2'-S-methylguanosine, along with normal deoxyguanosine and riboguanosine, starting from both C2'-endo and C3'-endo conformations using *ab initio* quantum mechanical calculations. All the structures were fully optimized at HF/6-31G\* level and single point energies with electron-correlation were obtained at the MP2/6-31G\*//HF/6-31G\* level. As shown in Table 1, the C2'-endo conformation of deoxyguanosine is estimated to be 0.6 kcal/mol more stable than the C3'-endo conformation in the gas-phase. The conformational preference of the C2'-endo over the C3'-endo conformation appears to be less dependent upon electron correlation as revealed by the MP2/6-31G\*//HF/6-31G\* values which also predict the same difference in energy. The opposite trend is noted for riboguanosine. At the HF/6-31G\* and MP2/6-31G\*//HF/6-31G\* levels, the C3'-endo

form of riboguanosine is shown to be about 0.65 and 1.41 kcal/mol more stable than the C2'endo form, respectively.

Table 1

5 Relative energies\* of the C3'-endo and C2'-endo conformations of representative nucleosides.

	HF/6-31G	MP2/6-31-G	CONTINUUM MODEL	AMBER
10 dG	0.60	0.56	0.88	0.65
rG	-0.65	-1.41	-0.28	-2.09
2'-O-MeG	-0.89	-1.79	-0.36	-0.86
2'-S-MeG	2.55	1.41	3.16	2.43

15

\*energies are in kcal/mol relative to the C2'-endo conformation

Table 1 also includes the relative energies of 2'-O-methylguanosine and 2'-S-methylguanosine in C2'-endo and C3'-endo conformation. This data indicates the electronic nature of C2'-substitution has a significant impact on the relative stability of these conformations. Substitution of the 2'-O-methyl group increases the preference for the C3'-endo conformation (when compared to riboguanosine) by about 0.4 kcal/mol at both the HF/6-31G\* and MP2/6-31G\*//HF/6-31G\* levels. In contrast, the 2'-S-methyl group reverses the trend. The C2'-endo conformation is favored by about 2.6 kcal/mol at the HF/6-31G\* level, while the same difference is reduced to 1.41 kcal/mol at the MP2/6-31G\*//HF/6-31G\* level. For comparison, and also to evaluate the accuracy of the molecular mechanical force-field parameters used for the 2'-O-methyl and 2'-S-methyl substituted nucleosides, we have calculated the gas phase energies of the nucleosides. The results reported in Table 1 indicate that the calculated relative energies of these nucleosides compare qualitatively well with the *ab initio* calculations.

30

Additional calculations were also performed to gauge the effect of solvation on the relative stability of nucleoside conformations. The estimated solvation effect using HF/6-31G\* geometries confirms that the relative energetic preference of the four nucleosides in the gas-phase is maintained in the aqueous phase as well (Table 1). Solvation effects were also examined using molecular dynamics simulations of the



nucleosides in explicit water. From these trajectories, one can observe the predominance of C2'-endo conformation for deoxyriboguanosine and 2'-S-methylriboguanosine while riboguanosine and 2'-O-methylriboguanosine prefer the C3'-endo conformation. These results are in much accord with the available NMR results on 2'-S-methylribonucleo-

5 sides. NMR studies of sugar puckering equilibrium using vicinal spin-coupling constants have indicated that the conformation of the sugar ring in 2'-S-methylpyrimidine nucleosides show an average of >75% S-character, whereas the corresponding purine analogs exhibit an average of >90% S-pucker [Fraser, A., Wheeler, P., Cook, P.D. and Sanghvi, Y.S., *J. Heterocycl. Chem.*, 1993, 30, 1277-1287]. It was

10 observed that the 2'-S-methyl substitution in deoxynucleoside confers more conformational rigidity to the sugar conformation when compared with deoxyribonucleosides.

Structural features of DNA:RNA, OMe-DNA:RNA and SMe-DNA:RNA hybrids were also observed. The average RMS deviation of the DNA:RNA structure from the

15 starting hybrid coordinates indicate the structure is stabilized over the length of the simulation with an approximate average RMS deviation of 1.0 Å. This deviation is due, in part, to inherent differences in averaged structures (i.e. the starting conformation) and structures at thermal equilibrium. The changes in sugar pucker conformation for three of the central base pairs of this hybrid are in good agreement with the observations made in

20 previous NMR studies. The sugars in the RNA strand maintain very stable geometries in the C3'-endo conformation with ring pucker values near 0°. In contrast, the sugars of the DNA strand show significant variability.

The average RMS deviation of the OMe-DNA:RNA is approximately 1.2 Å from the starting A-form conformation; while the SMe-DNA:RNA shows a slightly higher

25 deviation (approximately 1.8 Å) from the starting hybrid conformation. The SMe-DNA strand also shows a greater variance in RMS deviation, suggesting the S-methyl group may induce some structural fluctuations. The sugar puckers of the RNA complements maintain C3'-endo puckering throughout the simulation. As expected from the nucleoside calculations, however, significant differences are noted in the puckering of

30 the OMe-DNA and SMe-DNA strands, with the former adopting C3'-endo, and the latter, C1'-exo/C2'-endo conformations.

An analysis of the helicoidal parameters for all three hybrid structures has also been performed to further characterize the duplex conformation. Three of the more important axis-basepair parameters that distinguish the different forms of the duplexes,

X-displacement, propeller twist, and inclination, are reported in Table 2. Usually, an X-displacement near zero represents a B-form duplex; while a negative displacement, which is a direct measure of deviation of the helix from the helical axis, makes the structure appear more A-like in conformation. In A-form duplexes, these values typically vary from  $-4\text{\AA}$  to  $-5\text{\AA}$ . In comparing these values for all three hybrids, the SMe\_DNA:RNA hybrid shows the most deviation from the A-form value, the OMe\_DNA:RNA shows the least, and the DNA:RNA is intermediate. A similar trend is also evident when comparing the inclination and propeller twist values with ideal A-form parameters. These results are further supported by an analysis of the backbone and glycosidic torsion angles of the hybrid structures. Glycosidic angles ( $X$ ) of A-form geometries, for example, are typically near  $-159^\circ$  while B form values are near  $-102^\circ$ . These angles are found to be  $-162^\circ$ ,  $-133^\circ$ , and  $-108^\circ$  for the OMe-DNA, DNA, and SMe-DNA strands, respectively. All RNA complements adopt an  $X$  angle close to  $-160^\circ$ . In addition, "crankshaft" transitions were also noted in the backbone torsions of the central UpU steps of the RNA strand in the SMe-DNA:RNA and DNA;RNA hybrids. Such transitions suggest some local conformational changes may occur to relieve a less favorable global conformation. Taken overall, the results indicate the amount of A-character decreases as OMe-DNA:RNA > DNA:RNA > SMe-DNA:RNA, with the latter two adopting more intermediate conformations when compared to A- and B-form geometries.

Table 2

Average helical parameters derived from  
the last 500 ps of simulation time.

(canonical A-and B-form values are given for comparison)

Helicoidal Parameter	B-DNA (x-ray)	B-DNA (fibre)	A-DNA (fibre)	DNA:RNA	OMe_DNA: RNA	SMe_DNA: RNA
X-disp	1.2	0.0	-5.3	-4.5	-5.4	-3.5
Inclination	-2.3	1.5	20.7	11.6	15.1	0.7
Propeller	-16.4	-13.3	-7.5	-12.7	-15.8	-10.3

Stability of C2'-modified DNA:RNA hybrids was determined. Although the overall stability of the DNA:RNA hybrids depends on several factors including sequence-dependencies and the purine content in the DNA or RNA strands DNA:RNA hybrids are

usually less stable than RNA:RNA duplexes and, in some cases, even less stable than DNA:DNA duplexes. Available experimental data attributes the relatively lowered stability of DNA:RNA hybrids largely to its intermediate conformational nature between DNA:DNA (B-family) and RNA:RNA (A-family) duplexes. The overall

5 thermodynamic stability of nucleic acid duplexes may originate from several factors including the conformation of backbone, base-pairing and stacking interactions. While it is difficult to ascertain the individual thermodynamic contributions to the overall stabilization of the duplex, it is reasonable to argue that the major factors that promote increased stability of hybrid duplexes are better stacking interactions (electrostatic  $\pi$ - $\pi$

10 interactions) and more favorable groove dimensions for hydration. The C2'-S-methyl substitution has been shown to destabilize the hybrid duplex. The notable differences in the rise values among the three hybrids may offer some explanation. While the 2'-S-methyl group has a strong influence on decreasing the base-stacking through high rise values ( $\sim 3.2$  Å), the 2'-O-methyl group makes the overall structure more compact with a

15 rise value that is equal to that of A-form duplexes ( $\sim 2.6$  Å). Despite its overall A-like structural features, the SMe\_DNA:RNA hybrid structure possesses an average rise value of 3.2 Å which is quite close to that of B-family duplexes. In fact, some local base-steps (CG steps) may be observed to have unusually high rise values (as high as 4.5 Å). Thus, the greater destabilization of 2'-S-methyl substituted DNA:RNA hybrids may be partly

20 attributed to poor stacking interactions.

It has been postulated that RNase H binds to the minor groove of RNA:DNA hybrid complexes, requiring an intermediate minor groove width between ideal A- and B-form geometries to optimize interactions between the sugar phosphate backbone atoms and RNase H. A close inspection of the averaged structures for the hybrid duplexes

25 using computer simulations reveals significant variation in the minor groove width dimensions as shown in Table 3. Whereas the O-methyl substitution leads to a slight expansion of the minor groove width when compared to the standard DNA:RNA complex, the S-methyl substitution leads to a general contraction (approximately 0.9 Å). These changes are most likely due to the preferred sugar pucker noted for the

30 antisense strands which induce either A- or B-like single strand conformations. In addition to minor groove variations, the results also point to potential differences in the steric makeup of the minor groove. The O-methyl group points into the minor groove while the S-methyl is directed away towards the major groove. Essentially, the S-methyl

group has flipped through the bases into the major groove as a consequence of C2'-endo puckering.

Table 3

5

Minor groove widths averaged  
over the last 500 ps of simulation time

Phosphate Distance	DNA:RNA	OMe_DNA: RNA	SMe_DNA: RNA	DNA:RNA (B-form)	RNA:RNA (A-form)
P5-P20	15.27	16.82	13.73	14.19	17.32
P6-P19	15.52	16.79	15.73	12.66	17.12
P7-P18	15.19	16.40	14.08	11.10	16.60
P8-P17	15.07	16.12	14.00	10.98	16.14
P9-P16	15.29	16.25	14.98	11.65	16.93
P10-P15	15.37	16.57	13.92	14.05	17.69

### Chemistries Defined

10 Unless otherwise defined herein, alkyl means C<sub>1</sub>-C<sub>12</sub>, preferably C<sub>1</sub>-C<sub>8</sub>, and more preferably C<sub>1</sub>-C<sub>6</sub>, straight or (where possible) branched chain aliphatic hydrocarbyl.

Unless otherwise defined herein, heteroalkyl means C<sub>1</sub>-C<sub>12</sub>, preferably C<sub>1</sub>-C<sub>8</sub>, and more preferably C<sub>1</sub>-C<sub>6</sub>, straight or (where possible) branched chain aliphatic hydrocarbyl containing at least one, and preferably about 1 to about 3, hetero atoms in the chain, including the terminal portion of the chain. Preferred heteroatoms include N, O and S.

15 Unless otherwise defined herein, cycloalkyl means C<sub>3</sub>-C<sub>12</sub>, preferably C<sub>3</sub>-C<sub>8</sub>, and more preferably C<sub>3</sub>-C<sub>6</sub>, aliphatic hydrocarbyl ring.

Unless otherwise defined herein, alkenyl means C<sub>2</sub>-C<sub>12</sub>, preferably C<sub>2</sub>-C<sub>8</sub>, and more preferably C<sub>2</sub>-C<sub>6</sub> alkenyl, which may be straight or (where possible) branched hydrocarbyl moiety, which contains at least one carbon-carbon double bond.

20 Unless otherwise defined herein, alkynyl means C<sub>2</sub>-C<sub>12</sub>, preferably C<sub>2</sub>-C<sub>8</sub>, and more preferably C<sub>2</sub>-C<sub>6</sub> alkynyl, which may be straight or (where possible) branched hydrocarbyl moiety, which contains at least one carbon-carbon triple bond.

25 Unless otherwise defined herein, heterocycloalkyl means a ring moiety containing at least three ring members, at least one of which is carbon, and of which 1, 2 or three ring members are other than carbon. Preferably the number of carbon atoms

varies from 1 to about 12, preferably 1 to about 6, and the total number of ring members varies from three to about 15, preferably from about 3 to about 8. Preferred ring heteroatoms are N, O and S. Preferred heterocycloalkyl groups include morpholino, thiomorpholino, piperidinyl, piperazinyl, homopiperidinyl, homopiperazinyl,  
5 homomorpholino, homothiomorpholino, pyrrolodinyl, tetrahydrooxazolyl, tetrahydroimidazolyl, tetrahydrothiazolyl, tetrahydroisoxazolyl, tetrahydropyrrazolyl, furanyl, pyranyl, and tetrahydroisothiazolyl.

Unless otherwise defined herein, aryl means any hydrocarbon ring structure containing at least one aryl ring. Preferred aryl rings have about 6 to about 20 ring  
10 carbons. Especially preferred aryl rings include phenyl, naphthyl, anthracenyl, and phenanthrenyl.

Unless otherwise defined herein, hetaryl means a ring moiety containing at least one fully unsaturated ring, the ring consisting of carbon and non-carbon atoms. Preferably the ring system contains about 1 to about 4 rings. Preferably the number of  
15 carbon atoms varies from 1 to about 12, preferably 1 to about 6, and the total number of ring members varies from three to about 15, preferably from about 3 to about 8. Preferred ring heteroatoms are N, O and S. Preferred hetaryl moieties include pyrazolyl, thiophenyl, pyridyl, imidazolyl, tetrazolyl, pyridyl, pyrimidinyl, purinyl, quinazolinyl, quinoxalinyl, benzimidazolyl, benzothiophenyl, etc.

Unless otherwise defined herein, where a moiety is defined as a compound  
20 moiety, such as hetarylalkyl (hetaryl and alkyl), aralkyl (aryl and alkyl), etc., each of the sub-moieties is as defined herein.

Unless otherwise defined herein, an electron withdrawing group is a group, such as the cyano or isocyanato group that draws electronic charge away from the carbon to  
25 which it is attached. Other electron withdrawing groups of note include those whose electronegativities exceed that of carbon, for example halogen, nitro, or phenyl substituted in the ortho- or para-position with one or more cyano, isothiocyanato, nitro or halo groups.

Unless otherwise defined herein, the terms halogen and halo have their ordinary  
30 meanings. Preferred halo (halogen) substituents are Cl, Br, and I.

The aforementioned optional substituents are, unless otherwise herein defined, suitable substituents depending upon desired properties. Included are halogens (Cl, Br, I), alkyl, alkenyl, and alkynyl moieties, NO<sub>2</sub>, NH<sub>3</sub> (substituted and unsubstituted), acid

moieties (e.g.  $-\text{CO}_2\text{H}$ ,  $-\text{OSO}_3\text{H}_2$ , etc.), heterocycloalkyl moieties, hetaryl moieties, aryl moieties, etc.

In all the preceding formulae, the squiggle (~) indicates a bond to an oxygen or sulfur of the 5'-phosphate. Phosphate protecting groups include those described in US  
5 Patents No. US 5,760,209, US 5,614,621, US 6,051,699, US 6,020,475, US 6,326,478, US 6,169,177, US 6,121,437, US 6,465,628 each of which is expressly incorporated herein by reference in its entirety.

### Oligomer Synthesis

10 Oligomerization of modified and unmodified nucleosides is performed according to literature procedures for DNA (Protocols for Oligonucleotides and Analogs, Ed. Agrawal (1993), Humana Press) and/or RNA (Scaringe, Methods (2001), 23, 206-217. Gait et al., Applications of Chemically synthesized RNA in RNA:Protein Interactions, Ed. Smith (1998), 1-36. Gallo et al., Tetrahedron (2001), 57, 5707-5713) synthesis as  
15 appropriate. In addition specific protocols for the synthesis of oligomeric compounds of the invention are illustrated in the examples below.

The oligomeric compounds used in accordance with this invention may be conveniently and routinely made through the well-known technique of solid phase synthesis. Equipment for such synthesis is sold by several vendors including, for  
20 example, Applied Biosystems (Foster City, CA). Any other means for such synthesis known in the art may additionally or alternatively be employed. It is well known to use similar techniques to prepare oligonucleotides such as the phosphorothioates and alkylated derivatives.

The present invention is also useful for the preparation of oligomeric compounds  
25 incorporating at least one 2'-O-protected nucleoside. After incorporation and appropriate deprotection the 2'-O-protected nucleoside will be converted to a ribonucleoside at the position of incorporation. The number and position of the 2-ribonucleoside units in the final oligomeric compound can vary from one at any site or the strategy can be used to prepare up to a full 2'-OH modified oligomeric compound. All 2'-O-protecting groups  
30 amenable to the synthesis of oligomeric compounds are included in the present invention. In general a protected nucleoside is attached to a solid support by for example a succinate linker. Then the oligonucleotide is elongated by repeated cycles of deprotecting the 5'-terminal hydroxyl group, coupling of a further nucleoside unit, capping and oxidation (alternatively sulfurization). In a more frequently used method of

synthesis the completed oligonucleotide is cleaved from the solid support with the removal of phosphate protecting groups and exocyclic amino protecting groups by treatment with an ammonia solution. Then a further deprotection step is normally required for removal of the more specialized protecting groups used for the protection of  
5 2'-hydroxyl groups thereby affording the fully deprotected oligonucleotide.

A large number of 2'-O-protecting groups have been used for the synthesis of oligoribonucleotides but over the years more effective groups have been discovered. The key to an effective 2'-O-protecting group is that it is capable of selectively being introduced at the 2'-O-position and that it can be removed easily after synthesis without  
10 the formation of unwanted side products. The protecting group also needs to be inert to the normal deprotecting, coupling, and capping steps required for oligoribonucleotide synthesis. Some of the protecting groups used initially for oligoribonucleotide synthesis included tetrahydropyran-1-yl and 4-methoxytetrahydropyran-4-yl. These two groups are not compatible with all 5'-O-protecting groups so modified versions were used with  
15 5'-DMT groups such as 1-(2-fluorophenyl)-4-methoxypiperidin-4-yl (Fpmp). Reese has identified a number of piperidine derivatives (like Fpmp) that are useful in the synthesis of oligoribonucleotides including 1-[(chloro-4-methyl)phenyl]-4'-methoxypiperidin-4-yl (Reese et al., *Tetrahedron Lett.*, 1986, (27), 2291). Another approach was to replace the standard 5'-DMT (dimethoxytrityl) group with protecting groups that were removed  
20 under non-acidic conditions such as levuliny and 9-fluorenylmethoxycarbonyl. Such groups enable the use of acid labile 2'-protecting groups for oligoribonucleotide synthesis. Another more widely used protecting group initially used for the synthesis of oligoribonucleotides was the t-butyldimethylsilyl group (Ogilvie et al., *Tetrahedron Lett.*, 1974, 2861; Hakimelahi et al., *Tetrahedron Lett.*, 1981, (22), 2543; and Jones et al., *J. Chem. Soc. Perkin I.*, 2762). The 2'-O-protecting groups can require special reagents for their removal such as for example the t-butyldimethylsilyl group is normally removed after all other cleaving/deprotecting steps by treatment of the oligomeric compound with tetrabutylammonium fluoride (TBAF).

One group of researchers examined a number of 2'-O-protecting groups (Pitsch, S., *Chimia*, 2001, (55), 320-324.) The group examined fluoride labile and photolabile protecting groups that are removed using moderate conditions. One photolabile group that was examined was the [2-(nitrobenzyl)oxy]methyl (nbm) protecting group (Schwartz et al., *Bioorg. Med. Chem. Lett.*, 1992, (2), 1019.) Other groups examined included a number structurally related formaldehyde acetal-derived, 2'-O-protecting  
30

groups. Also prepared were a number of related protecting groups for preparing 2'-O-alkylated nucleoside phosphoramidites including 2'-O-[(triisopropylsilyl)oxy]methyl (2'-O-CH<sub>2</sub>-O-Si(iPr)<sub>3</sub>, TOM). One 2'-O-protecting group that was prepared to be used orthogonally to the TOM group was 2'-O-[(R)-1-(2-nitrophenyl)ethoxy]methyl ((R)-  
5 mnbm).

Another strategy using a fluoride labile 5'-O-protecting group (non-acid labile) and an acid labile 2'-O-protecting group has been reported (Scaringe, Stephen A., Methods, 2001, (23) 206-217). A number of possible silyl ethers were examined for 5'-O-protection and a number of acetals and orthoesters were examined for 2'-O-protection.  
10 The protection scheme that gave the best results was 5'-O-silyl ether-2'-ACE (5'-O-bis(trimethylsiloxy)cyclododecyloxysilyl ether (DOD)-2'-O-bis(2-acetoxyethoxy)methyl (ACE). This approach uses a modified phosphoramidite synthesis approach in that some different reagents are required that are not routinely used for RNA/DNA synthesis.

Although a lot of research has focused on the synthesis of oligoribonucleotides  
15 the main RNA synthesis strategies that are presently being used commercially include 5'-O-DMT-2'-O-t-butyl dimethylsilyl (TBDMS), 5'-O-DMT-2'-O-[1(2-fluorophenyl)-4-methoxypiperidin-4-yl] (FPMP), 2'-O-[(triisopropylsilyl)oxy]methyl (2'-O-CH<sub>2</sub>-O-Si(iPr)<sub>3</sub> (TOM), and the 5'-O-silyl ether-2'-ACE (5'-O-bis(trimethylsiloxy)cyclododecyloxysilyl ether (DOD)-2'-O-bis(2-acetoxyethoxy)methyl  
20 (ACE). A current list of some of the major companies currently offering RNA products include Pierce Nucleic Acid Technologies, Dharmacon Research Inc., Ameri Biotechnologies Inc., and Integrated DNA Technologies, Inc. One company, Princeton Separations, is marketing an RNA synthesis activator advertised to reduce coupling times especially with TOM and TBDMS chemistries. Such an activator would also be  
25 amenable to the present invention.

The primary groups being used for commercial RNA synthesis are:

TBDMS = 5'-O-DMT-2'-O-t-butyl dimethylsilyl;  
TOM = 2'-O-[(triisopropylsilyl)oxy]methyl;  
DOD/ACE = (5'-O-bis(trimethylsiloxy)cyclododecyloxysilyl ether-2'-O-bis(2-  
30 acetoxyethoxy)methyl  
FPMP = 5'-O-DMT-2'-O-[1(2-fluorophenyl)-4-methoxypiperidin-4-yl] .

All of the aforementioned RNA synthesis strategies are amenable to the present invention. Strategies that would be a hybrid of the above e.g. using a 5'-protecting group



from one strategy with a 2'-O-protecting from another strategy is also amenable to the present invention.

The preparation of ribonucleotides and oligomeric compounds having at least one ribonucleoside incorporated and all the possible configurations falling in between these  
5 two extremes are encompassed by the present invention. The corresponding oligomeric compounds can be hybridized to further oligomeric compounds including oligoribonucleotides having regions of complementarity to form double-stranded (duplexed) oligomeric compounds. Such double stranded oligonucleotide moieties have been shown in the art to modulate target expression and regulate translation as well as  
10 RNA processing via an antisense mechanism. Moreover, the double-stranded moieties may be subject to chemical modifications (Fire et al., *Nature*, 1998, 391, 806-811; Timmons and Fire, *Nature* 1998, 395, 854; Timmons et al., *Gene*, 2001, 263, 103-112; Tabara et al., *Science*, 1998, 282, 430-431; Montgomery et al., *Proc. Natl. Acad. Sci. USA*, 1998, 95, 15502-15507; Tuschl et al., *Genes Dev.*, 1999, 13, 3191-3197; Elbashir et al., *Nature*, 2001, 411, 494-498; Elbashir et al., *Genes Dev.* 2001, 15, 188-200). For example, such double-stranded moieties have been shown to inhibit the target by the classical hybridization of antisense strand of the duplex to the target, thereby triggering enzymatic degradation of the target (Tijsterman et al., *Science*, 2002, 295, 694-697).

The methods of preparing oligomeric compounds of the present invention can  
20 also be applied in the areas of drug discovery and target validation. The present invention comprehends the use of the oligomeric compounds and preferred targets identified herein in drug discovery efforts to elucidate relationships that exist between proteins and a disease state, phenotype, or condition. These methods include detecting or modulating a target peptide comprising contacting a sample, tissue, cell, or organism with the  
25 oligomeric compounds of the present invention, measuring the nucleic acid or protein level of the target and/or a related phenotypic or chemical endpoint at some time after treatment, and optionally comparing the measured value to a non-treated sample or sample treated with a further oligomeric compound of the invention. These methods can also be performed in parallel or in combination with other experiments to determine the  
30 function of unknown genes for the process of target validation or to determine the validity of a particular gene product as a target for treatment or prevention of a particular disease, condition, or phenotype.

Effect of nucleoside modifications on RNAi activity is evaluated according to existing literature (Elbashir et al., Nature (2001), 411, 494-498; Nishikura et al., Cell (2001), 107, 415-416; and Bass et al., Cell (2000), 101, 235-238.)

## 5 **Targets of the invention**

"Targeting" an antisense oligomeric compound to a particular nucleic acid molecule, in the context of this invention, can be a multistep process. The process usually begins with the identification of a target nucleic acid whose function is to be modulated. This target nucleic acid may be, for example, a cellular gene (or mRNA  
10 transcribed from the gene) whose expression is associated with a particular disorder or disease state, or a nucleic acid molecule from an infectious agent.

The targeting process usually also includes determination of at least one target region, segment, or site within the target nucleic acid for the antisense interaction to occur such that the desired effect, e.g., modulation of expression, will result. Within the  
15 context of the present invention, the term "region" is defined as a portion of the target nucleic acid having at least one identifiable structure, function, or characteristic. Within regions of target nucleic acids are segments. "Segments" are defined as smaller or sub-portions of regions within a target nucleic acid. "Sites," as used in the present invention, are defined as positions within a target nucleic acid. The terms region, segment, and site  
20 can also be used to describe an oligomeric compound of the invention such as for example a gapped oligomeric compound having 3 separate segments.

Since, as is known in the art, the translation initiation codon is typically 5'-AUG (in transcribed mRNA molecules; 5'-ATG in the corresponding DNA molecule), the translation initiation codon is also referred to as the "AUG codon," the "start codon" or  
25 the "AUG start codon". A minority of genes have a translation initiation codon having the RNA sequence 5'-GUG, 5'-UUG or 5'-CUG, and 5'-AUA, 5'-ACG and 5'-CUG have been shown to function *in vivo*. Thus, the terms "translation initiation codon" and "start codon" can encompass many codon sequences, even though the initiator amino acid in each instance is typically methionine (in eukaryotes) or formylmethionine (in  
30 prokaryotes). It is also known in the art that eukaryotic and prokaryotic genes may have two or more alternative start codons, any one of which may be preferentially utilized for translation initiation in a particular cell type or tissue, or under a particular set of conditions. In the context of the invention, "start codon" and "translation initiation codon" refer to the codon or codons that are used *in vivo* to initiate translation of an

mRNA transcribed from a gene encoding a nucleic acid target, regardless of the sequence(s) of such codons. It is also known in the art that a translation termination codon (or "stop codon") of a gene may have one of three sequences, i.e., 5'-UAA, 5'-UAG and 5'-UGA (the corresponding DNA sequences are 5'-TAA, 5'-TAG and 5'-TGA, respectively).

The terms "start codon region" and "translation initiation codon region" refer to a portion of such an mRNA or gene that encompasses from about 25 to about 50 contiguous nucleotides in either direction (i.e., 5' or 3') from a translation initiation codon. Similarly, the terms "stop codon region" and "translation termination codon region" refer to a portion of such an mRNA or gene that encompasses from about 25 to about 50 contiguous nucleotides in either direction (i.e., 5' or 3') from a translation termination codon. Consequently, the "start codon region" (or "translation initiation codon region") and the "stop codon region" (or "translation termination codon region") are all regions which may be targeted effectively with the antisense oligomeric compounds of the present invention.

The open reading frame (ORF) or "coding region," which is known in the art to refer to the region between the translation initiation codon and the translation termination codon, is also a region which may be targeted effectively. Within the context of the present invention, a preferred region is the intragenic region encompassing the translation initiation or termination codon of the open reading frame (ORF) of a gene.

Other target regions include the 5' untranslated region (5'UTR), known in the art to refer to the portion of an mRNA in the 5' direction from the translation initiation codon, and thus including nucleotides between the 5' cap site and the translation initiation codon of an mRNA (or corresponding nucleotides on the gene), and the 3' untranslated region (3'UTR), known in the art to refer to the portion of an mRNA in the 3' direction from the translation termination codon, and thus including nucleotides between the translation termination codon and 3' end of an mRNA (or corresponding nucleotides on the gene). The 5' cap site of an mRNA comprises an N7-methylated guanosine residue joined to the 5'-most residue of the mRNA via a 5'-5' triphosphate linkage. The 5' cap region of an mRNA is considered to include the 5' cap structure itself as well as the first 50 nucleotides adjacent to the cap site. It is also preferred to target the 5' cap region.

Although some eukaryotic mRNA transcripts are directly translated, many contain one or more regions, known as "introns," which are excised from a transcript

before it is translated. The remaining (and therefore translated) regions are known as "exons" and are spliced together to form a continuous mRNA sequence. Targeting splice sites, i.e., intron-exon junctions or exon-intron junctions, may also be particularly useful in situations where aberrant splicing is implicated in disease, or where an overproduction  
5 of a particular splice product is implicated in disease. Aberrant fusion junctions due to rearrangements or deletions are also preferred target sites. mRNA transcripts produced via the process of splicing of two (or more) mRNAs from different gene sources are known as "fusion transcripts". It is also known that introns can be effectively targeted using antisense oligomeric compounds targeted to, for example, DNA or pre-mRNA.

10 It is also known in the art that alternative RNA transcripts can be produced from the same genomic region of DNA. These alternative transcripts are generally known as "variants". More specifically, "pre-mRNA variants" are transcripts produced from the same genomic DNA that differ from other transcripts produced from the same genomic DNA in either their start or stop position and contain both intronic and exonic sequences.

15 Upon excision of one or more exon or intron regions, or portions thereof during splicing, pre-mRNA variants produce smaller "mRNA variants". Consequently, mRNA variants are processed pre-mRNA variants and each unique pre-mRNA variant must always produce a unique mRNA variant as a result of splicing. These mRNA variants are also known as "alternative splice variants". If no splicing of the pre-mRNA variant  
20 occurs then the pre-mRNA variant is identical to the mRNA variant.

It is also known in the art that variants can be produced through the use of alternative signals to start or stop transcription and that pre-mRNAs and mRNAs can possess more than one start codon or stop codon. Variants that originate from a pre-mRNA or mRNA that use alternative start codons are known as "alternative start  
25 variants" of that pre-mRNA or mRNA. Those transcripts that use an alternative stop codon are known as "alternative stop variants" of that pre-mRNA or mRNA. One specific type of alternative stop variant is the "polyA variant" in which the multiple transcripts produced result from the alternative selection of one of the "polyA stop signals" by the transcription machinery, thereby producing transcripts that terminate at  
30 unique polyA sites. Within the context of the invention, the types of variants described herein are also preferred target nucleic acids.

The locations on the target nucleic acid to which the preferred antisense oligomeric compounds hybridize are hereinbelow referred to as "preferred target segments." As used herein the term "preferred target segment" is defined as at least an

8-nucleobase portion of a target region to which an active antisense oligomeric compound is targeted. While not wishing to be bound by theory, it is presently believed that these target segments represent accessible portions of the target nucleic acid for hybridization.

5 Exemplary preferred antisense oligomeric compounds include oligomeric compounds that comprise at least the 8 consecutive nucleobases from the 5'-terminus of a targeted nucleic acid e.g. a cellular gene or mRNA transcribed from the gene (the remaining nucleobases being a consecutive stretch of the same oligonucleotide beginning immediately upstream of the 5'-terminus of the antisense compound which is specifically  
10 hybridizable to the target nucleic acid and continuing until the oligonucleotide contains from about 8 to about 80 nucleobases). Similarly preferred antisense oligomeric compounds are represented by oligonucleotide sequences that comprise at least the 8 consecutive nucleobases from the 3'-terminus of one of the illustrative preferred  
15 antisense compounds (the remaining nucleobases being a consecutive stretch of the same oligonucleotide beginning immediately downstream of the 3'-terminus of the antisense compound which is specifically hybridizable to the target nucleic acid and continuing until the oligonucleotide contains from about 8 to about 80 nucleobases). One having skill in the art armed with the preferred antisense compounds illustrated herein will be able, without undue experimentation, to identify further preferred antisense compounds.

20 Once one or more target regions, segments or sites have been identified, antisense oligomeric compounds are chosen which are sufficiently complementary to the target, i.e., hybridize sufficiently well and with sufficient specificity, to give the desired effect.

In accordance with one embodiment of the present invention, a series of preferred compositions of nucleic acid duplexes comprising the antisense oligomeric compounds  
25 of the present invention and their complements can be designed for a specific target or targets. The ends of the strands may be modified by the addition of one or more natural or modified nucleobases to form an overhang. The sense strand of the duplex is then designed and synthesized as the complement of the antisense strand and may also contain modifications or additions to either terminus. For example, in one embodiment, both  
30 strands of the duplex would be complementary over the central nucleobases, each having overhangs at one or both termini.

For example, a duplex comprising an antisense oligomeric compound having the sequence CGAGAGGCGGACGGACCG and having a two-nucleobase overhang of deoxythymidine(dT) would have the following structure:

```

      cgagaggcggacgggaccgdTdT  Antisense Strand
      |||||
dTdTgctctccgectgccctggc      Complement Strand

```

RNA strands of the duplex can be synthesized by methods disclosed herein or  
 5 purchased from various RNA synthesis companies such as for example Dharmacon  
 Research Inc., (Lafayette, CO). Once synthesized, the complementary strands are  
 annealed. The single strands are aliquoted and diluted to a concentration of 50  $\mu$ M.  
 Once diluted, 30  $\mu$ L of each strand is combined with 15  $\mu$ L of a 5X solution of annealing  
 10 buffer. The final concentration of the buffer is 100 mM potassium acetate, 30 mM  
 HEPES-KOH pH 7.4, and 2mM magnesium acetate. The final volume is 75  $\mu$ L. This  
 solution is incubated for 1 minute at 90°C and then centrifuged for 15 seconds. The tube  
 is allowed to sit for 1 hour at 37°C at which time the dsRNA duplexes are used in  
 experimentation. The final concentration of the dsRNA compound is 20  $\mu$ M. This  
 solution can be stored frozen (-20°C) and freeze-thawed up to 5 times.

15 Once prepared, the desired synthetic duplexes are evaluated for their ability to  
 modulate target expression. When cells reach 80% confluency, they are treated with  
 synthetic duplexes comprising at least one oligomeric compound of the invention. For  
 cells grown in 96-well plates, wells are washed once with 200  $\mu$ L OPTI-MEM-1  
 reduced-serum medium (Gibco BRL) and then treated with 130  $\mu$ L of OPTI-MEM-1  
 20 containing 12  $\mu$ g/mL LIPOFECTIN (Gibco BRL) and the desired dsRNA compound at a  
 final concentration of 200 nM. After 5 hours of treatment, the medium is replaced with  
 fresh medium. Cells are harvested 16 hours after treatment, at which time RNA is  
 isolated and target reduction measured by RT-PCR.

In a further embodiment, the "preferred target segments" identified herein may  
 25 be employed in a screen for additional oligomeric compounds that modulate the  
 expression of a target. "Modulators" are those oligomeric compounds that decrease or  
 increase the expression of a nucleic acid molecule encoding a target and which comprise  
 at least an 8-nucleobase portion which is complementary to a preferred target segment.  
 The screening method comprises the steps of contacting a preferred target segment of a  
 30 nucleic acid molecule encoding a target with one or more candidate modulators, and  
 selecting for one or more candidate modulators which decrease or increase the  
 expression of a nucleic acid molecule encoding a target. Once it is shown that the  
 candidate modulator or modulators are capable of modulating (e.g. either decreasing or  
 increasing) the expression of a nucleic acid molecule encoding a target, the modulator

may then be employed in further investigative studies of the function of a target, or for use as a research, diagnostic, or therapeutic agent in accordance with the present invention.

The preferred target segments of the present invention may also be combined  
5 with their respective complementary antisense oligomeric compounds of the present invention to form stabilized double-stranded (duplexed) oligonucleotides.

### Hybridization

In the context of this invention, "hybridization" occurs when two sequences come  
10 together with enough base complementarity to form a double stranded region. The source of the two sequences can be synthetic or native and can occur in a single strand when the strand has regions of self complementarity. In the present invention, the preferred mechanism of pairing involves hydrogen bonding, which may be Watson-Crick, Hoogsteen or reversed Hoogsteen hydrogen bonding, between complementary  
15 nucleoside or nucleotide bases (nucleobases) of the strands of oligomeric compounds or between an oligomeric compound and a target nucleic acid. For example, adenine and thymine are complementary nucleobases which pair through the formation of hydrogen bonds. Hybridization can occur under varying circumstances.

An antisense oligomeric compound is specifically hybridizable when binding of  
20 the compound to the target nucleic acid interferes with the normal function of the target nucleic acid to cause a loss of activity, and there is a sufficient degree of complementarity to avoid non-specific binding of the antisense oligomeric compound to non-target nucleic acid sequences under conditions in which specific binding is desired, i.e., under physiological conditions in the case of *in vivo* assays or therapeutic treatment,  
25 and under conditions in which assays are performed in the case of *in vitro* assays.

In the present invention the phrase "stringent hybridization conditions" or "stringent conditions" refers to conditions under which an oligomeric compound of the invention will hybridize to its target sequence, but to a minimal number of other sequences. Stringent conditions are sequence-dependent and will vary with different  
30 circumstances and in the context of this invention, "stringent conditions" under which oligomeric compounds hybridize to a target sequence are determined by the nature and composition of the oligomeric compounds and the assays in which they are being investigated.

"Complementary," as used herein, refers to the capacity for precise pairing of two nucleobases regardless of where the two are located. For example, if a nucleobase at a certain position of an oligomeric compound is capable of hydrogen bonding with a nucleobase at a certain position of a target nucleic acid, the target nucleic acid being a DNA, RNA, or oligonucleotide molecule, then the position of hydrogen bonding between the oligonucleotide and the target nucleic acid is considered to be a complementary position. The oligomeric compound and the further DNA, RNA, or oligonucleotide molecule are complementary to each other when a sufficient number of complementary positions in each molecule are occupied by nucleobases which can hydrogen bond with each other. Thus, "specifically hybridizable" and "complementary" are terms which are used to indicate a sufficient degree of precise pairing or complementarity over a sufficient number of nucleobases such that stable and specific binding occurs between the oligonucleotide and a target nucleic acid.

It is understood in the art that the sequence of an antisense oligomeric compound need not be 100% complementary to that of its target nucleic acid to be specifically hybridizable. Moreover, an oligonucleotide may hybridize over one or more segments such that intervening or adjacent segments are not involved in the hybridization event (e.g., a loop structure or hairpin structure). It is preferred that the antisense oligomeric compounds of the present invention comprise at least 70% sequence complementarity to a target region within the target nucleic acid, more preferably that they comprise 90% sequence complementarity and even more preferably comprise 95% sequence complementarity to the target region within the target nucleic acid sequence to which they are targeted. For example, an antisense oligomeric compound in which 18 of 20 nucleobases of the antisense oligomeric compound are complementary to a target region, and would therefore specifically hybridize, would represent 90 percent complementarity. In this example, the remaining noncomplementary nucleobases may be clustered or interspersed with complementary nucleobases and need not be contiguous to each other or to complementary nucleobases. As such, an antisense oligomeric compound which is 18 nucleobases in length having 4 (four) noncomplementary nucleobases which are flanked by two regions of complete complementarity with the target nucleic acid would have 77.8% overall complementarity with the target nucleic acid and would thus fall within the scope of the present invention. Percent complementarity of an antisense oligomeric compound with a region of a target nucleic acid can be determined routinely using BLAST programs (basic local alignment search tools) and PowerBLAST programs



known in the art (Altschul et al., *J. Mol. Biol.*, 1990, 215, 403-410; Zhang and Madden, *Genome Res.*, 1997, 7, 649-656).

### Screening and Target Validation

5           In a further embodiment, "preferred target segments" may be employed in a screen for additional oligomeric compounds that modulate the expression of a selected protein. "Modulators" are those oligomeric compounds that decrease or increase the expression of a nucleic acid molecule encoding a protein and which comprise at least an 8-nucleobase portion which is complementary to a preferred target segment. The  
10 screening method comprises the steps of contacting a preferred target segment of a nucleic acid molecule encoding a protein with one or more candidate modulators, and selecting for one or more candidate modulators which decrease or increase the expression of a nucleic acid molecule encoding a protein. Once it is shown that the candidate modulator or modulators are capable of modulating (e.g. either decreasing or  
15 increasing) the expression of a nucleic acid molecule encoding a peptide, the modulator may then be employed in further investigative studies of the function of the peptide, or for use as a research, diagnostic, or therapeutic agent in accordance with the present invention.

          The preferred target segments of the present invention may also be combined  
20 with their respective complementary antisense oligomeric compounds of the present invention to form stabilized double-stranded (duplexed) oligonucleotides. Such double stranded oligonucleotide moieties have been shown in the art to modulate target expression and regulate translation as well as RNA processing via an antisense mechanism. Moreover, the double-stranded moieties may be subject to chemical  
25 modifications (Fire et al., *Nature*, 1998, 391, 806-811; Timmons and Fire, *Nature* 1998, 395, 854; Timmons et al., *Gene*, 2001, 263, 103-112; Tabara et al., *Science*, 1998, 282, 430-431; Montgomery et al., *Proc. Natl. Acad. Sci. USA*, 1998, 95, 15502-15507; Tuschl et al., *Genes Dev.*, 1999, 13, 3191-3197; Elbashir et al., *Nature*, 2001, 411, 494-498; Elbashir et al., *Genes Dev.* 2001, 15, 188-200). For example, such double-stranded  
30 moieties have been shown to inhibit the target by the classical hybridization of antisense strand of the duplex to the target, thereby triggering enzymatic degradation of the target (Tijsterman et al., *Science*, 2002, 295, 694-697).

          The compositions comprising oligomeric compounds of the present invention can also be applied in the areas of drug discovery and target validation. The present

invention comprehends the use of the oligomeric compounds and preferred targets identified herein in drug discovery efforts to elucidate relationships that exist between proteins and a disease state, phenotype, or condition. These methods include detecting or modulating a target peptide comprising contacting a sample, tissue, cell, or organism  
5 with the oligomeric compounds of the present invention, measuring the nucleic acid or protein level of the target and/or a related phenotypic or chemical endpoint at some time after treatment, and optionally comparing the measured value to a non-treated sample or sample treated with a further oligomeric compound of the invention. These methods can also be performed in parallel or in combination with other experiments to determine the  
10 function of unknown genes for the process of target validation or to determine the validity of a particular gene product as a target for treatment or prevention of a particular disease, condition, or phenotype.

Effect of nucleoside modifications on RNAi activity is evaluated according to existing literature (Elbashir et al., Nature (2001), 411, 494-498; Nishikura et al., Cell  
15 (2001), 107, 415-416; and Bass et al., Cell (2000), 101, 235-238.)

#### **Kits, Research Reagents, Diagnostics, and Therapeutics**

The compositions of oligomeric compounds of the present invention can be utilized for diagnostics, therapeutics, prophylaxis and as research reagents and kits.  
20 Furthermore, antisense oligonucleotides, which are able to inhibit gene expression with exquisite specificity, are often used by those of ordinary skill to elucidate the function of particular genes or to distinguish between functions of various members of a biological pathway.

For use in kits and diagnostics, the compositions of the present invention, either  
25 alone or in combination with other oligomeric compounds or therapeutics, can be used as tools in differential and/or combinatorial analyses to elucidate expression patterns of a portion or the entire complement of genes expressed within cells and tissues.

As one nonlimiting example, expression patterns within cells or tissues treated with one or more antisense oligomeric compounds are compared to control cells or  
30 tissues not treated with antisense oligomeric compounds and the patterns produced are analyzed for differential levels of gene expression as they pertain, for example, to disease association, signaling pathway, cellular localization, expression level, size, structure or function of the genes examined. These analyses can be performed on stimulated or

unstimulated cells and in the presence or absence of other compounds and or oligomeric compounds that affect expression patterns.

Examples of methods of gene expression analysis known in the art include DNA arrays or microarrays (Brazma and Vilo, *FEBS Lett.*, **2000**, 480, 17-24; Celis, *et al.*, *FEBS Lett.*, **2000**, 480, 2-16), SAGE (serial analysis of gene expression)(Madden, *et al.*, *Drug Discov. Today*, **2000**, 5, 415-425), READS (restriction enzyme amplification of digested cDNAs) (Prashar and Weissman, *Methods Enzymol.*, **1999**, 303, 258-72), TOGA (total gene expression analysis) (Sutcliffe, *et al.*, *Proc. Natl. Acad. Sci. U. S. A.*, **2000**, 97, 1976-81), protein arrays and proteomics (Celis, *et al.*, *FEBS Lett.*, **2000**, 480, 2-16; Jungblut, *et al.*, *Electrophoresis*, **1999**, 20, 2100-10), expressed sequence tag (EST) sequencing (Celis, *et al.*, *FEBS Lett.*, **2000**, 480, 2-16; Larsson, *et al.*, *J. Biotechnol.*, **2000**, 80, 143-57), subtractive RNA fingerprinting (SuRF) (Fuchs, *et al.*, *Anal. Biochem.*, **2000**, 286, 91-98; Larson, *et al.*, *Cytometry*, **2000**, 41, 203-208), subtractive cloning, differential display (DD) (Jurecic and Belmont, *Curr. Opin. Microbiol.*, **2000**, 3, 316-21), comparative genomic hybridization (Carulli, *et al.*, *J. Cell Biochem. Suppl.*, **1998**, 31, 286-96), FISH (fluorescent *in situ* hybridization) techniques (Going and Gusterson, *Eur. J. Cancer*, **1999**, 35, 1895-904) and mass spectrometry methods (To, *Comb. Chem. High Throughput Screen*, **2000**, 3, 235-41).

The compositions of the invention are useful for research and diagnostics in one sense because the oligomeric compounds of the compositions hybridize to nucleic acids encoding proteins. For example, oligonucleotides that are shown to hybridize with such efficiency and under such conditions as disclosed herein as to be effective protein inhibitors will also be effective primers or probes under conditions favoring gene amplification or detection, respectively. These primers and probes are useful in methods requiring the specific detection of nucleic acid molecules encoding proteins and in the amplification of the nucleic acid molecules for detection or for use in further studies. Hybridization of the antisense oligonucleotides, particularly the primers and probes, of the invention with a nucleic acid can be detected by means known in the art. Such means may include conjugation of an enzyme to the oligonucleotide, radiolabelling of the oligonucleotide or any other suitable detection means. Kits using such detection means for detecting the level of selected proteins in a sample may also be prepared.

The specificity and sensitivity of antisense methodologies is also harnessed by those of skill in the art for therapeutic uses. Antisense oligomeric compounds have been employed as therapeutic moieties in the treatment of disease states in animals, including

humans. Antisense oligonucleotide drugs, including ribozymes, have been safely and effectively administered to humans and numerous clinical trials are presently underway. It is thus established that antisense oligomeric compounds can be useful therapeutic modalities that can be configured to be useful in treatment regimes for the treatment of  
5 cells, tissues and animals, especially humans.

For therapeutics, an animal, preferably a human, suspected of having a disease or disorder which can be treated by modulating the expression of a selected protein is treated by administering compositions of the invention in accordance with this invention. For example, in one non-limiting embodiment, the methods comprise the step of  
10 administering to the animal in need of treatment, a therapeutically effective amount of a protein inhibitor. The protein inhibitors of the present invention effectively inhibit the activity of the protein or inhibit the expression of the protein. In one embodiment, the activity or expression of a protein in an animal is inhibited by about 10%. Preferably, the activity or expression of a protein in an animal is inhibited by about 30%. More  
15 preferably, the activity or expression of a protein in an animal is inhibited by 50% or more.

For example, the reduction of the expression of a protein may be measured in serum, adipose tissue, liver or any other body fluid, tissue or organ of the animal. Preferably, the cells contained within the fluids, tissues or organs being analyzed contain  
20 a nucleic acid molecule encoding a protein and/or the protein itself.

The compositions of the invention can be utilized in pharmaceutical compositions by adding an effective amount to a suitable pharmaceutically acceptable diluent or carrier. Use of the compositions and methods of the invention may also be useful prophylactically.  
25

### **Formulations**

The compositions of the invention may also be admixed, encapsulated, conjugated or otherwise associated with other molecules, molecule structures or mixtures of compounds, as for example, liposomes, receptor-targeted molecules, oral, rectal,  
30 topical or other formulations, for assisting in uptake, distribution and/or absorption. Representative United States patents that teach the preparation of such uptake, distribution and/or absorption-assisting formulations include, but are not limited to, U.S.:  
5,108,921; 5,354,844; 5,416,016; 5,459,127; 5,521,291; 5,543,158; 5,547,932;  
5,583,020; 5,591,721; 4,426,330; 4,534,899; 5,013,556; 5,108,921; 5,213,804;

5,227,170; 5,264,221; 5,356,633; 5,395,619; 5,416,016; 5,417,978; 5,462,854;  
5,469,854; 5,512,295; 5,527,528; 5,534,259; 5,543,152; 5,556,948; 5,580,575; and  
5,595,756, each of which is herein incorporated by reference.

The compositions of the invention encompass any pharmaceutically acceptable  
5 salts, esters, or salts of such esters, or any other compound which, upon administration to  
an animal, including a human, is capable of providing (directly or indirectly) the  
biologically active metabolite or residue thereof. Accordingly, for example, the  
disclosure is also drawn to prodrugs and pharmaceutically acceptable salts of the  
compositions of the invention, pharmaceutically acceptable salts of such prodrugs, and  
10 other bioequivalents. The term "prodrug" indicates a therapeutic agent that is prepared  
in an inactive form that is converted to an active form (i.e., drug) within the body or cells  
thereof by the action of endogenous enzymes or other chemicals and/or conditions. In  
particular, prodrug versions of the oligonucleotides of the invention are prepared as  
SATE [(S-acetyl-2-thioethyl) phosphate] derivatives according to the methods disclosed  
15 in WO 93/24510 to Gosselin *et al.*, published December 9, 1993 or in WO 94/26764 and  
U.S. 5,770,713 to Imbach *et al.*

The term "pharmaceutically acceptable salts" refers to physiologically and  
pharmaceutically acceptable salts of the oligomeric compounds of the invention: i.e.,  
salts that retain the desired biological activity of the parent compound and do not impart  
20 undesired toxicological effects thereto. For oligonucleotides, preferred examples of  
pharmaceutically acceptable salts and their uses are further described in U.S. Patent  
6,287,860, which is incorporated herein in its entirety.

The present invention also includes pharmaceutical compositions and  
formulations which include the compositions of the invention. The pharmaceutical  
25 compositions of the present invention may be administered in a number of ways  
depending upon whether local or systemic treatment is desired and upon the area to be  
treated. Administration may be topical (including ophthalmic and to mucous membranes  
including vaginal and rectal delivery), pulmonary, e.g., by inhalation or insufflation of  
powders or aerosols, including by nebulizer; intratracheal, intranasal, epidermal and  
30 transdermal), oral or parenteral. Parenteral administration includes intravenous,  
intraarterial, subcutaneous, intraperitoneal or intramuscular injection or infusion; or  
intracranial, e.g., intrathecal or intraventricular, administration. Oligonucleotides with at  
least one 2'-O-methoxyethyl modification are believed to be particularly useful for oral  
administration. Pharmaceutical compositions and formulations for topical administration

may include transdermal patches, ointments, lotions, creams, gels, drops, suppositories, sprays, liquids and powders. Conventional pharmaceutical carriers, aqueous, powder or oily bases, thickeners and the like may be necessary or desirable. Coated condoms, gloves and the like may also be useful.

5           The pharmaceutical formulations of the present invention, which may conveniently be presented in unit dosage form, may be prepared according to conventional techniques well known in the pharmaceutical industry. Such techniques include the step of bringing into association the active ingredients with the pharmaceutical carrier(s) or excipient(s). In general, the formulations are prepared by  
10 uniformly and intimately bringing into association the active ingredients with liquid carriers or finely divided solid carriers or both, and then, if necessary, shaping the product.

The compositions of the present invention may be formulated into any of many possible dosage forms such as, but not limited to, tablets, capsules, gel capsules, liquid  
15 syrups, soft gels, suppositories, and enemas. The compositions of the present invention may also be formulated as suspensions in aqueous, non-aqueous or mixed media. Aqueous suspensions may further contain substances which increase the viscosity of the suspension including, for example, sodium carboxymethylcellulose, sorbitol and/or dextran. The suspension may also contain stabilizers.

20           Pharmaceutical compositions of the present invention include, but are not limited to, solutions, emulsions, foams and liposome-containing formulations. The pharmaceutical compositions and formulations of the present invention may comprise one or more penetration enhancers, carriers, excipients or other active or inactive ingredients.

25           Emulsions are typically heterogenous systems of one liquid dispersed in another in the form of droplets usually exceeding 0.1  $\mu\text{m}$  in diameter. Emulsions may contain additional components in addition to the dispersed phases, and the active drug which may be present as a solution in either the aqueous phase, oily phase or itself as a separate phase. Microemulsions are included as an embodiment of the present invention.

30           Emulsions and their uses are well known in the art and are further described in U.S. Patent 6,287,860, which is incorporated herein in its entirety.

Formulations of the present invention include liposomal formulations. As used in the present invention, the term "liposome" means a vesicle composed of amphiphilic

lipids arranged in a spherical bilayer or bilayers. Liposomes are unilamellar or multilamellar vesicles which have a membrane formed from a lipophilic material and an aqueous interior that contains the composition to be delivered. Cationic liposomes are positively charged liposomes which are believed to interact with negatively charged DNA molecules to form a stable complex. Liposomes that are pH-sensitive or negatively-charged are believed to entrap DNA rather than complex with it. Both cationic and noncationic liposomes have been used to deliver DNA to cells.

Liposomes also include "sterically stabilized" liposomes, a term which, as used herein, refers to liposomes comprising one or more specialized lipids that, when incorporated into liposomes, result in enhanced circulation lifetimes relative to liposomes lacking such specialized lipids. Examples of sterically stabilized liposomes are those in which part of the vesicle-forming lipid portion of the liposome comprises one or more glycolipids or is derivatized with one or more hydrophilic polymers, such as a polyethylene glycol (PEG) moiety. Liposomes and their uses are further described in U.S. Patent 6,287,860, which is incorporated herein in its entirety.

The pharmaceutical formulations and compositions of the present invention may also include surfactants. The use of surfactants in drug products, formulations and in emulsions is well known in the art. Surfactants and their uses are further described in U.S. Patent 6,287,860, which is incorporated herein in its entirety.

In one embodiment, the present invention employs various penetration enhancers to effect the efficient delivery of nucleic acids, particularly oligonucleotides. In addition to aiding the diffusion of non-lipophilic drugs across cell membranes, penetration enhancers also enhance the permeability of lipophilic drugs. Penetration enhancers may be classified as belonging to one of five broad categories, *i.e.*, surfactants, fatty acids, bile salts, chelating agents, and non-chelating non-surfactants. Penetration enhancers and their uses are further described in U.S. Patent 6,287,860, which is incorporated herein in its entirety.

One of skill in the art will recognize that formulations are routinely designed according to their intended use, *i.e.* route of administration.

Preferred formulations for topical administration include those in which the oligonucleotides of the invention are in admixture with a topical delivery agent such as lipids, liposomes, fatty acids, fatty acid esters, steroids, chelating agents and surfactants. Preferred lipids and liposomes include neutral (e.g. dioleoylphosphatidyl DOPE ethanolamine, dimyristoylphosphatidyl choline DMPC, distearoylphosphatidyl choline)

negative (e.g. dimyristoylphosphatidyl glycerol DMPG) and cationic (e.g. dioleoyltetramethylaminopropyl DOTAP and dioleoylphosphatidyl ethanolamine DOTMA).

For topical or other administration, oligonucleotides of the invention may be  
5 encapsulated within liposomes or may form complexes thereto, in particular to cationic liposomes. Alternatively, oligonucleotides may be complexed to lipids, in particular to cationic lipids. Preferred fatty acids and esters, pharmaceutically acceptable salts thereof, and their uses are further described in U.S. Patent 6,287,860, which is incorporated herein in its entirety. Topical formulations are described in detail in United  
10 States patent application 09/315,298 filed on May 20, 1999, which is incorporated herein by reference in its entirety.

Compositions and formulations for oral administration include powders or granules, microparticulates, nanoparticulates, suspensions or solutions in water or non-aqueous media, capsules, gel capsules, sachets, tablets or minitables. Thickeners,  
15 flavoring agents, diluents, emulsifiers, dispersing aids or binders may be desirable. Preferred oral formulations are those in which oligonucleotides of the invention are administered in conjunction with one or more penetration enhancers surfactants and chelators. Preferred surfactants include fatty acids and/or esters or salts thereof, bile acids and/or salts thereof. Preferred bile acids/salts and fatty acids and their uses are  
20 further described in U.S. Patent 6,287,860, which is incorporated herein in its entirety. Also preferred are combinations of penetration enhancers, for example, fatty acids/salts in combination with bile acids/salts. A particularly preferred combination is the sodium salt of lauric acid, capric acid and UDCA. Further penetration enhancers include polyoxyethylene-9-lauryl ether, polyoxyethylene-20-cetyl ether. Oligonucleotides of the  
25 invention may be delivered orally, in granular form including sprayed dried particles, or complexed to form micro or nanoparticles. Oligonucleotide complexing agents and their uses are further described in U.S. Patent 6,287,860, which is incorporated herein in its entirety. Oral formulations for oligonucleotides and their preparation are described in detail in United States applications 09/108,673 (filed July 1, 1998), 09/315,298 (filed  
30 May 20, 1999) and 10/071,822, filed February 8, 2002, each of which is incorporated herein by reference in their entirety.

Compositions and formulations for parenteral, intrathecal or intraventricular administration may include sterile aqueous solutions which may also contain buffers,



diluents and other suitable additives such as, but not limited to, penetration enhancers, carrier compounds and other pharmaceutically acceptable carriers or excipients.

Certain embodiments of the invention provide pharmaceutical compositions containing one or more of the compositions of the invention and one or more other  
5 chemotherapeutic agents which function by a non-antisense mechanism. Examples of such chemotherapeutic agents include but are not limited to cancer chemotherapeutic drugs such as daunorubicin, daunomycin, dactinomycin, doxorubicin, epirubicin, idarubicin, esorubicin, bleomycin, mafosfamide, ifosfamide, cytosine arabinoside, bis-chloroethylnitrosurea, busulfan, mitomycin C, actinomycin D, mithramycin, prednisone,  
10 hydroxyprogesterone, testosterone, tamoxifen, dacarbazine, procarbazine, hexamethylmelamine, pentamethylmelamine, mitoxantrone, amsacrine, chlorambucil, methylcyclohexylnitrosurea, nitrogen mustards, melphalan, cyclophosphamide, 6-mercaptopurine, 6-thioguanine, cytarabine, 5-azacytidine, hydroxyurea, deoxycorformycin, 4-hydroxyperoxycyclophosphoramidate, 5-fluorouracil (5-FU), 5-  
15 fluorodeoxyuridine (5-FUdR), methotrexate (MTX), colchicine, taxol, vincristine, vinblastine, etoposide (VP-16), trimetrexate, irinotecan, topotecan, gemcitabine, teniposide, cisplatin and diethylstilbestrol (DES). When used with the compositions of the invention, such chemotherapeutic agents may be used individually (*e.g.*, 5-FU and oligonucleotide), sequentially (*e.g.*, 5-FU and oligonucleotide for a period of time  
20 followed by MTX and oligonucleotide), or in combination with one or more other such chemotherapeutic agents (*e.g.*, 5-FU, MTX and oligonucleotide, or 5-FU, radiotherapy and oligonucleotide). Anti-inflammatory drugs, including but not limited to nonsteroidal anti-inflammatory drugs and corticosteroids, and antiviral drugs, including but not limited to ribivirin, vidarabine, acyclovir and ganciclovir, may also be combined in  
25 compositions of the invention. Combinations of compositions of the invention and other non-antisense drugs are also within the scope of this invention. One or more compositions of the invention can be used in combination with other therapeutic agents to create a cocktail as is currently the strategy for certain viral infections.

In another related embodiment, therapeutically effective combination therapies  
30 may comprise the use of two or more compositions of the invention wherein the multiple compositions are targeted to a single or multiple nucleic acid targets. Numerous examples of antisense oligomeric compounds are known in the art. Two or more combined compounds may be used together or sequentially

## Dosing

The formulation of therapeutic compositions and their subsequent administration (dosing) is believed to be within the skill of those in the art. Dosing is dependent on severity and responsiveness of the disease state to be treated, with the course of treatment

5 lasting from several days to several months, or until a cure is effected or a diminution of the disease state is achieved. Optimal dosing schedules can be calculated from measurements of drug accumulation in the body of the patient. Persons of ordinary skill can easily determine optimum dosages, dosing methodologies and repetition rates. Optimum dosages may vary depending on the relative potency of individual

10 oligonucleotides, and can generally be estimated based on  $EC_{50}$ s found to be effective in *in vitro* and *in vivo* animal models. In general, dosage is from 0.01 ug to 100 g per kg of body weight, and may be given once or more daily, weekly, monthly or yearly, or even once every 2 to 20 years. Persons of ordinary skill in the art can easily estimate repetition rates for dosing based on measured residence times and concentrations of the

15 drug in bodily fluids or tissues. Following successful treatment, it may be desirable to have the patient undergo maintenance therapy to prevent the recurrence of the disease state, wherein the oligonucleotide is administered in maintenance doses, ranging from 0.01 ug to 100 g per kg of body weight, once or more daily, to once every 20 years.

While the present invention has been described with specificity in accordance

20 with certain of its preferred embodiments, the following examples serve only to illustrate the invention and are not intended to limit the same.

## Example 1

### Comparative dose response study of various siRNA constructs (AS-P=O or P=S/S full 2'-O-methyl P=O or P=S) with and without overhangs

25

The activity of selected double stranded compositions was determined against % PTEN mRNA levels (normalized to RiboGreen, Hela Cells, dose response at 0.6 nM, 3.0 nM, 15 nM and 75 nM). Eight duplex siRNA's were compared to the untreated control. The antisense strands were full PO blunt or with dTdT overhangs and full PS blunt. The

30 sense strands used were full P=O RNA or full 2'-O-CH<sub>3</sub> 20 mers either full P=O or full P=S.

<u>ISIS NO's:</u>	<u>Description antisense/sense</u>	<u>Dose</u>	<u>PTEN mRNA Level</u>
N/A	Untreated control	0.00	1.00

	335449/308746	P=O RNA/P=O RNA	75	0.25	(blunt ends)
	303912/308746	P=S RNA/P=O RNA	75	0.25	(blunt ends)
	335449/330696	P=O RNA/P=O 2'-O-CH <sub>3</sub>	75	0.40	(blunt ends)
	303912/330696	P=S RNA/P=O 2'-O-CH <sub>3</sub>	75	0.23	(blunt ends)
5	335449/341315	P=O RNA/P=S 2'-O-CH <sub>3</sub>	75	0.33	(blunt ends)
	303912/341315	P=S RNA/P=S 2'-O-CH <sub>3</sub>	75	0.21	(blunt ends)
	297803/271784	P=O RNA/P=O RNA	75	0.14	(3'-dTdT ends)
	297803/334465	P=O RNA/P=O 2'-O-CH <sub>3</sub>	75	0.46	(3'-dTdT ends)
10					

	<u>SEQ ID NO:</u>	<u>ISIS NO:</u>	<u>Sequence 5'-3'</u>
1		303912	P-U*U*U*G*U*C*U*C*U*G*G*U*C*C*U*U*A*C*U*U Antisense strand
15	1	335449	P-UUUGUCUCUGGUCCUUACUU Antisense strand
	2	308746	AAGUAAGGACCAGAGACAAA Antisense strand
	8	297803	UUUGUCUCUGGUCCUUACUTT Antisense strand
20	2	330696	A <sub>m</sub> A <sub>m</sub> G <sub>m</sub> U <sub>m</sub> A <sub>m</sub> A <sub>m</sub> G <sub>m</sub> G <sub>m</sub> A <sub>m</sub> C <sub>m</sub> C <sub>m</sub> A <sub>m</sub> G <sub>m</sub> A <sub>m</sub> G <sub>m</sub> A <sub>m</sub> C <sub>m</sub> A <sub>m</sub> A <sub>m</sub> A <sub>m</sub> Sense strand
	2	341315	A <sub>m</sub> *A <sub>m</sub> *G <sub>m</sub> *U <sub>m</sub> *A <sub>m</sub> *A <sub>m</sub> *G <sub>m</sub> *G <sub>m</sub> *A <sub>m</sub> *C <sub>m</sub> *C <sub>m</sub> *A <sub>m</sub> *G <sub>m</sub> *A <sub>m</sub> *G <sub>m</sub> *A <sub>m</sub> * C <sub>m</sub> *A <sub>m</sub> *A <sub>m</sub> *A <sub>m</sub> Sense strand
25	9	271784	AGUAAGGACCAGAGACAAATT Sense strand
	9	334465	A <sub>m</sub> G <sub>m</sub> U <sub>m</sub> A <sub>m</sub> A <sub>m</sub> G <sub>m</sub> G <sub>m</sub> A <sub>m</sub> C <sub>m</sub> C <sub>m</sub> A <sub>m</sub> G <sub>m</sub> A <sub>m</sub> G <sub>m</sub> A <sub>m</sub> C <sub>m</sub> A <sub>m</sub> A <sub>m</sub> A <sub>m</sub> dTdT Sense strand

30           Where \* is a phosphorothioate internucleoside linkage, P- is a 5'-phosphate group and m is a 2'-O-methyl group.

          It was shown that the full P=S antisense when duplexed with either the P=O or P=S full 2'-O-CH<sub>3</sub> strand showed comparable activity to the native P=O siRNA duplex. These results show an increase in duplex stability without loss of activity. Activity is

also shown for constructs having P=O linkages in the antisense strand. Each of the constructs showed a dose response at the relative concentrations used with the activities in the table above taken from the 75 nM dose.

5 **Example 2**

**Relative activities of full P=O 2'-O-Methyl sense containing compositions**

The activities of selected siRNA's compositions were determined relative to reduction of PTEN mRNA levels (Hela Cells, 175 nM doses, using Lipofectin, ribogreen normalized). Each of the siRNA compositions examined were either full P=O RNA or  
 10 full P=O 2'-O-CH<sub>3</sub> modified strand.

<u>SEQ ID NO:</u>	<u>ISIS NO:</u>	<u>Sequence 5'-3'</u>	
1	326908	P-U*U*U*G*U*C*U*C*U*G*G*U*C*C*U*U*A*C*U*U-Bi Antisense strand	
15	1	331693	P-UUUGUCUCUGGUCCUUACUU-Bi Antisense strand
	2	330696	A <sub>m</sub> A <sub>m</sub> G <sub>m</sub> U <sub>m</sub> A <sub>m</sub> A <sub>m</sub> G <sub>m</sub> G <sub>m</sub> A <sub>m</sub> C <sub>m</sub> C <sub>m</sub> A <sub>m</sub> G <sub>m</sub> A <sub>m</sub> G <sub>m</sub> A <sub>m</sub> C <sub>m</sub> A <sub>m</sub> A <sub>m</sub> A <sub>m</sub> Sense strand
	2	308746	AAGUAAGGACCAGAGACAAA Sense strand
20			

Where \* is a phosphorothioate internucleoside linkage, P- is a 5'-phosphate group, m is a 2'-O-methyl group and Bi is a conjugated biotin group.

Three different double stranded constructs were studied to see their effect on reduction of mRNA in the assay relative to untreated control.

25 The rank order of the 3 constructs is shown below:

<u>Order</u>	<u>ISIS NO's as/s</u>	<u>as/s strands</u>
1	331693/308746	5'-P P=O/P=O
2	326908/330696	5'-P P=S/P=O 2'-OCH <sub>3</sub>
	326908/308746	5'-P P=S/P=O

30 Starting with a 5'-phosphate modified phosphodiester antisense and a pure RNA sense strand it was seen that some activity was lost when the backbone was modified to a full P=S (1 vs 3). Some of the activity was restored when full 2'-OCH<sub>3</sub> modified sense strand was used against the full P=S strand (1 vs 2).

**Example 3****Activities of full P=O 2'-O-Methyl sense containing compositions**

The activities of selected siRNA compositions were determined relative to reduction of PTEN mRNA levels (Hela Cells, 175 nM doses). Each of the siRNA  
 5 compositions had an RNA antisense strand having either P=O or P=S internucleoside linkages with the sense strand set as full P=O 2'-O-CH<sub>3</sub> with or without a 3'-biotin group.

	<u>ISIS NO's:</u>	<u>Description antisense/sense</u>	<u>PTEN mRNA Level</u>
	N/A	Untreated control	1.00
10			<u>29592 SITE</u>
	303912/330696	P=S RNA/P=O 2'-O-CH <sub>3</sub>	0.19
	326908/330696	P=S RNA/P=O 2'-O-CH <sub>3</sub> 3'-Bi	0.17
	331693/330696	P=O RNA/P=O 2'-O-CH <sub>3</sub> 3'-Bi	0.28
			<u>116847 SITE</u>
15	300857/290224	P=S RNA/P=O 2'-O-CH <sub>3</sub>	0.19
	271766/290224	P=O RNA/P=O 2'-O-CH <sub>3</sub>	0.54

	<u>SEQ ID NO:</u>	<u>ISIS NO:</u>	<u>Sequence 5'-3'</u>
20	3	29592	<b>(antisense sequences)</b> T*G*T*C*T*C*T*G*G*T*C*C*T*T*A*C*T*T*
	4	29592	TTTGTCTCTGGTCCTTACT-dTdT
	1	303912	P-U*U*U*G*U*C*U*C*U*G*G*U*C*C*U*U*A*C*U*U*
	1	326908	P-U*U*U*G*U*C*U*C*U*G*G*U*C*C*U*U*A*C*U*U*-Bi
	1	331693	P-UUUGUCUCUGGUCCUUACUU-Bi
25	5	300857	C*U*G*C*U*A*G*C*C*U*C*U*G*G*A*U*U*U*G*A
	6	271766	CUGCUAGCCUCUGGAUUUG-dTdT
			<b>(sense sequences)</b>
	2	330696	A <sub>m</sub> A <sub>m</sub> G <sub>m</sub> U <sub>m</sub> A <sub>m</sub> A <sub>m</sub> G <sub>m</sub> G <sub>m</sub> A <sub>m</sub> C <sub>m</sub> C <sub>m</sub> A <sub>m</sub> G <sub>m</sub> A <sub>m</sub> G <sub>m</sub> A <sub>m</sub> C <sub>m</sub> A <sub>m</sub> A <sub>m</sub> A <sub>m</sub>
		308746	AAGUAAGGACCAGAGACAAA
30	7	290224	C <sub>m</sub> A <sub>m</sub> A <sub>m</sub> A <sub>m</sub> U <sub>m</sub> C <sub>m</sub> C <sub>m</sub> A <sub>m</sub> G <sub>m</sub> A <sub>m</sub> G <sub>m</sub> G <sub>m</sub> C <sub>m</sub> U <sub>m</sub> A <sub>m</sub> G <sub>m</sub> C <sub>m</sub> A <sub>m</sub> G <sub>m</sub> -dTdT

Where \* is a phosphorothioate internucleoside linkage, P- is a 5'-phosphate group, m is a 2'-O-methyl group and Bi is a biotin group.

It was shown that compositions comprising full P=S antisense RNA and full P=O 2'-O-CH<sub>3</sub> targeted to either the 29592 site or the 16847 site showed activity greater than about 20% of control. At the good activity and at the 16847 site the activity was reduced to higher than 50% when the antisense was switched from full P=S to full P=O. Another  
 5 obseration was that activity was slightly enhanced when a 3'-biotin group was introduced in the full P=S antisense RNA/full P=O 2'-O-CH<sub>3</sub> targeted to the 29592 site and reduced when the biotin construct was prepared having P=O linkages in the antisense strand.

#### Example 4

#### 10 Activities of full P=O 2'-O-Methyl sense containing compositions

The activities of selected siRNA's compositions were determined relative to reduction of PTEN mRNA levels (Hela Cells, 5, 20 and 50 nM doses). Three compositions, two targeted to the 116847 site and one targeted to the 29592 site were examined with the sense strand in each case being a full P=O 2'-O-CH<sub>3</sub>. The unmodified  
 15 RNA/RNA control was targeted to the 116847 site.

<u>ISIS NO's:</u>	<u>Description antisense/sense</u>	<u>PTEN mRNA Level</u>
N/A	Untreated control	1.00
<b><u>116847 SITE</u></b>		
20 271766/271790	P=O RNA/P=O RNA	0.17
271766/290224	P=O RNA/P=O 2'-O-CH <sub>3</sub>	0.80
300857/290224	P=S RNA/P=O 2'-O-CH <sub>3</sub>	0.27
<b><u>29592 SITE</u></b>		
303912/330696	P=O RNA/P=O 2'-O-CH <sub>3</sub>	0.16

25

<u>SEQ ID NO:</u>	<u>ISIS NO:</u>	<u>Sequence 5'-3'</u>
<b>(antisense sequences)</b>		
1	303912	P-U*U*U*G*U*C*U*C*U*G*G*U*C*C*U*U*A*C*U*U (29592 site)
30 5	300857	P-C*U*G*C*U*A*G*C*C*U*C*U*G*G*A*U*U*U*G*A (116847 site)
6	271766	CUGCUAGCCUCUGGAUUUG-dTdT (116847 site)
<b>(sense sequences)</b>		

7	271790	CAAUCCAGAGGCUAGCAG-dTdT (116847 site)	
2	330696	A <sub>m</sub> A <sub>m</sub> G <sub>m</sub> U <sub>m</sub> A <sub>m</sub> A <sub>m</sub> G <sub>m</sub> G <sub>m</sub> A <sub>m</sub> C <sub>m</sub> C <sub>m</sub> A <sub>m</sub> G <sub>m</sub> A <sub>m</sub> G <sub>m</sub> A <sub>m</sub> C <sub>m</sub> A <sub>m</sub> A <sub>m</sub> A <sub>m</sub> (29592 site)	
5	7	290224	C <sub>m</sub> A <sub>m</sub> A <sub>m</sub> A <sub>m</sub> U <sub>m</sub> C <sub>m</sub> C <sub>m</sub> A <sub>m</sub> G <sub>m</sub> A <sub>m</sub> G <sub>m</sub> G <sub>m</sub> C <sub>m</sub> U <sub>m</sub> A <sub>m</sub> G <sub>m</sub> C <sub>m</sub> A <sub>m</sub> G <sub>m</sub> - dTdT (116847 site)

Where \* is a phosphorothioate internucleoside linkage, P- is a 5'-phosphate group and m is a 2'-O-methyl group.

10 The results show that the two constructs having full P=S antisense/full P=O 2'-O-CH<sub>3</sub> sense chemistries gave comparable activity to the RNA/RNA unmodified control. Replacement of the linkage on the antisense strand with full P=O linkages reduces the activity from around the 20% level to about the 80% level when looking at the 20 nM dose responses.

15

### Example 5

#### Relative activities of Blunt and 3'-dTdT overhanging compositions

The activity of various compositions targeted to the 29592 site of PTEN was determined as normalized to cRAF (2, 10, and 50 nM doses).

20

<u>ISIS NO's:</u>	<u>Description antisense/sense</u>	<u>PTEN mRNA Level</u>
N/A	Untreated control	1.00
297803/271784	P=O RNA/P=O RNA (3'-dTdT's)	0.15
25 297803/334465	P=O RNA/P=O 2'-O-CH <sub>3</sub> (3'-dTdT's)	0.53
335449/308746	P=O RNA/P=O RNA (blunt ended)	0.22
335449/330696	P=O RNA/P=O 2'-O-CH <sub>3</sub> (blunt ended)	0.30
303912/308746	P=O RNA/P=O RNA (blunt ended)	0.25
30 303912/303696	P=S RNA/P=O 2'-O-CH <sub>3</sub> (blunt ended)	0.28

PTEN mRNA levels compared at the 10 nM doses.

SEQ ID NO: ISIS NO: Sequence 5'-3'

		<b>(antisense sequences)</b>
8	297803	UUUGUCUCUGGUCCUUACUdTdT
1	335449	P-UUUGUCUCUGGUCCUUACUU
1	303912	P-U*U*U*G*U*C*U*C*U*G*G*U*C*C*U*U*A*C*U*U
5		<b>(sense sequences)</b>
9	271784	AGUAAGGACCAGAGACAAAdTdT
9	334465	A <sub>m</sub> G <sub>m</sub> U <sub>m</sub> A <sub>m</sub> A <sub>m</sub> G <sub>m</sub> G <sub>m</sub> A <sub>m</sub> C <sub>m</sub> C <sub>m</sub> A <sub>m</sub> G <sub>m</sub> A <sub>m</sub> G <sub>m</sub> A <sub>m</sub> C <sub>m</sub> A <sub>m</sub> A <sub>m</sub> A <sub>m</sub> dTdT
2	308746	AAGUAAGGACCAGAGACAAA
2	330696	A <sub>m</sub> A <sub>m</sub> G <sub>m</sub> U <sub>m</sub> A <sub>m</sub> A <sub>m</sub> G <sub>m</sub> G <sub>m</sub> A <sub>m</sub> C <sub>m</sub> C <sub>m</sub> A <sub>m</sub> G <sub>m</sub> A <sub>m</sub> G <sub>m</sub> A <sub>m</sub> C <sub>m</sub> A <sub>m</sub> A <sub>m</sub> A <sub>m</sub>

10           Where \* is a phosphorothioate internucleoside linkage, P- is a 5'-phosphate group and m is a 2'-O-methyl group.

              It was seen that that the full P=O 2'-O-CH<sub>3</sub> sense strand/full P=S antisense strand construct showed good activity in the blunt end format.

15   **Example 6**

**Activities of full P=O 2'-O-Methyl sense containing compositions**

              The activities of selected siRNA compositions were determined relative to reduction of PTEN mRNA levels (normalized to Ribogreen, Hela Cells, .6, 3, 15 and 75 nM doses, activity in table from 75 nM dose). All of the compositions were targeted to the 116847 site. The activities of the compositions were compared to untreated control, unmodified RNA having 3'-dTdT overhangs and the same RNA having P=S linkages in the antisense strand. The five compositions examined all had full 2'-O-methyl P=O sense strands. The antisense strands were P=O and P=S blunt, P=O and P=S with dTdT overhangs and one antisense strand was P=S blunt with a 3'-biotin group.

25

<u>ISIS NO's:</u>	<u>Description antisense/sense</u>	<u>PTEN mRNA Level</u>
N/A	Untreated control	1.00
		<u>116847 SITE</u>
271766/271790	P=O RNA/P=O RNA	0.30 (dTdT ended)
30 344185/271790	P=S RNA/P=O RNA	0.36 (dTdT ended)
271766/290224	P=O RNA/P=O 2'-O-CH <sub>3</sub>	0.90 (dTdT ended)
300851/344184	P=O RNA/P=O 2'-O-CH <sub>3</sub>	0.45 (blunt ended)



	344185/290224	P=S RNA/P=O 2'-O-CH <sub>3</sub>	0.39 (dTdT ended)
	300857/344184	P=S RNA/P=O 2'-O-CH <sub>3</sub>	0.53 (Blunt ended)
5	300857/290224	P=S RNA Bi/P=O 2'-O-CH <sub>3</sub>	0.40 (Blunt/dTdT ended)

<u>SEQ ID NO:</u>	<u>ISIS NO:</u>	<u>Sequence 5'-3'</u> (antisense sequences)
5	300857	P-C*U*G*C*U*A*G*C*C*U*C*U*G*G*A*U*U*U*G*A
10	6	271766 CUGCUAGCCUCUGGAUUUG-dTdT
6	344185	C*U*G*C*U*A*G*C*C*U*C*U*G*G*A*U*U*U*G*-dT*dT
		(sense sequences)
7	271790	CAAUCCAGAGGCUAGCAG-dTdT
7	290224	C <sub>m</sub> A <sub>m</sub> A <sub>m</sub> A <sub>m</sub> U <sub>m</sub> C <sub>m</sub> C <sub>m</sub> A <sub>m</sub> G <sub>m</sub> A <sub>m</sub> G <sub>m</sub> G <sub>m</sub> C <sub>m</sub> U <sub>m</sub> A <sub>m</sub> G <sub>m</sub> C <sub>m</sub> A <sub>m</sub> G <sub>m</sub> - dTdT
15	15	344184 U <sub>m</sub> C <sub>m</sub> A <sub>m</sub> A <sub>m</sub> A <sub>m</sub> U <sub>m</sub> C <sub>m</sub> C <sub>m</sub> A <sub>m</sub> G <sub>m</sub> A <sub>m</sub> G <sub>m</sub> G <sub>m</sub> C <sub>m</sub> U <sub>m</sub> A <sub>m</sub> G <sub>m</sub> C <sub>m</sub> A <sub>m</sub> G <sub>m</sub>

Where \* is a phosphorothioate internucleoside linkage, P- is a 5'-phosphate group and m is a 2'-O-methyl group.

20 All of the constructs showed measureable activity with some differences seen between the 3'-dTdT and blunt ended versions of identical sequences. The results show that constructs having full P=S antisense/full P=O 2'-O-CH<sub>3</sub> sense chemistries gave comparable activity to the RNA/RNA unmodified control which either blunt or overhanging ends. The P=O/P=O constructs also showed activity with the blunt ended  
25 construct being more active.

### Example 7

#### Comparative study of P=O/P=O (2'-O-Methyl) constructs targeted to 3 separate sites

30 The activity of the RNA P=O/P=O versus the P=O/P=O-2'-O-Methyl constructs was examined (% mRNA PTEN, normalized to cRAF, 2, 10 and 50 nM doses) at three separate sites (29592, 29593 and 29597). All sequences are 3'-dTdT.

<u>ISIS NO's:</u>	<u>Description antisense/sense</u>	<u>PTEN mRNA Level</u>
-------------------	------------------------------------	------------------------

	N/A	Untreated control	1.00 (29592 site)
	297803/271784	P=O RNA/P=O RNA	0.32
	344179/334465	P=S RNA/P=O RNA	0.78
	297804/271785	P=O RNA/P=O 2'-O-CH <sub>3</sub>	0.29
5	297804/334466	P=O RNA/P=O 2'-O-CH <sub>3</sub>	0.68
	297807/271788	P=S RNA/P=O 2'-O-CH <sub>3</sub>	0.17
	297807/334470	P=S RNA/P=O 2'-O-CH <sub>3</sub>	0.18

	<u>SEQ ID NO:</u>	<u>ISIS NO:</u>	<u>Sequence 5'-3'</u>
10			<b>(antisense sequences)</b>
	8	297803	UUUGUCUCUGGUCCUUACUTT
	19	297804	CACAUAGCGCCUCUGACUG-dTdT
	16	297807	AUGAAGAAUGUAUUUACCC-dTdT
			<b>(sense sequences)</b>
15	9	271784	AGUAAGGACCAGAGACAAATT
	9	334465	A <sub>m</sub> G <sub>m</sub> U <sub>m</sub> A <sub>m</sub> A <sub>m</sub> G <sub>m</sub> G <sub>m</sub> A <sub>m</sub> C <sub>m</sub> C <sub>m</sub> A <sub>m</sub> G <sub>m</sub> A <sub>m</sub> G <sub>m</sub> A <sub>m</sub> C <sub>m</sub> A <sub>m</sub> A <sub>m</sub> A <sub>m</sub> dTdT
	17	271785	CAGUCAGAGGCGCUAUGUG-dTdT
	17	334466	C <sub>m</sub> A <sub>m</sub> G <sub>m</sub> U <sub>m</sub> C <sub>m</sub> A <sub>m</sub> G <sub>m</sub> A <sub>m</sub> G <sub>m</sub> G <sub>m</sub> C <sub>m</sub> G <sub>m</sub> C <sub>m</sub> U <sub>m</sub> A <sub>m</sub> U <sub>m</sub> G <sub>m</sub> U <sub>m</sub> G <sub>m</sub> - dTdT
20	18	271788	GGGUAAAUACAUUCUUCAU-dTdT
	18	334470	G <sub>m</sub> G <sub>m</sub> G <sub>m</sub> U <sub>m</sub> A <sub>m</sub> A <sub>m</sub> A <sub>m</sub> U <sub>m</sub> A <sub>m</sub> C <sub>m</sub> A <sub>m</sub> U <sub>m</sub> U <sub>m</sub> C <sub>m</sub> U <sub>m</sub> U <sub>m</sub> C <sub>m</sub> A <sub>m</sub> U <sub>m</sub> - dTdT

Where \* is a phosphorothioate internucleoside linkage, P- is a 5'-phosphate group and m is a 2'-O-methyl group.

25 Each of the constructs examined showed a dose response in the assay. The activities are given for the 50 nM dose. The results show that the activity of the P=O/P=O full 2'-O-methyl construct varies relative to the P=O/P=O construct depending on the site that is targeted. The activity of the 2'-O-methyl construct at the 29597 site is comparable to the unmodified construct.

30

### Example 8

#### Comparative study of P=O(S)/P=O, 2'-O-Methyl constructs

The activity of the RNA P=O(S)/P=O versus the P=O(S)/P=O-2'-O-Methyl constructs was examined (% mRNA PTEN, normalized to Ribogreen, .6, 3, 15, and 75

nM doses). The unmodified sequences were full P=O with 3'-dTdT overhangs. The full P=O 2'-O-methyl constructs were prepared with 3'-dTdT overhangs and with blunt ends. The full P=S antisense having full P=O 2'-O-methyl constructs were prepared with 3'-dTdT overhangs and with 3'-dTdT overhangs in the antisense strand with a blunt end in the sense strand. Activities are shown at the 75 nM dose.

	<u>ISIS NO's:</u>	<u>Description antisense/sense</u>	<u>PTEN mRNA Level</u>
	N/A	Untreated control	1.00 (29593 site)
	297804/271785	P=O RNA/P=O RNA	0.14 (3'-dTdT)
10	297804/334466	P=O RNA/P=O 2'-O-CH <sub>3</sub>	0.69 (3'-dTdT)
	344180/271785	P=S RNA/P=O RNA	0.87 (3'-dTdT)
	344180/334466	P=S RNA/P=O 2'-O-CH <sub>3</sub>	0.72 (3'-dTdT)
	334468/334467	P=O RNA/P=O 2'-O-CH <sub>3</sub>	0.25 (blunt)
	344180/334467	P=S RNA/P=O 2'-O-CH <sub>3</sub>	1.03 (3'-
15	dTdT/blunt)		
	116846	5/10/5 MOE gapmer	0.32

	<u>SEQ ID NO:</u>	<u>ISIS NO:</u>	<u>Sequence 5'-3'</u> <u>(antisense sequences)</u>
20	19	297804	CACAUAGCGCCUCUGACUG-dTdT
	17	271785	CAGUCAGAGGCGCUAUGUG-dTdT
	17	334466	C <sub>m</sub> A <sub>m</sub> G <sub>m</sub> U <sub>m</sub> C <sub>m</sub> A <sub>m</sub> G <sub>m</sub> A <sub>m</sub> G <sub>m</sub> G <sub>m</sub> C <sub>m</sub> G <sub>m</sub> C <sub>m</sub> U <sub>m</sub> A <sub>m</sub> U <sub>m</sub> G <sub>m</sub> U <sub>m</sub> G <sub>m</sub> -dTdT
	19	344180	C*A*C*A*U*A*G*C*G*C*C*U*C*U*G*A*C*U*G*-dTdT
25	20	334468	ACACAUAGCGCCUCUGACUG
	21	334467	C <sub>m</sub> A <sub>m</sub> G <sub>m</sub> U <sub>m</sub> C <sub>m</sub> A <sub>m</sub> G <sub>m</sub> A <sub>m</sub> G <sub>m</sub> G <sub>m</sub> C <sub>m</sub> G <sub>m</sub> C <sub>m</sub> U <sub>m</sub> A <sub>m</sub> U <sub>m</sub> G <sub>m</sub> U <sub>m</sub> G <sub>m</sub> U <sub>m</sub>
	22	116846	<u>ACGTAACGGCCCTGTCTAGG</u> (T=5-Methyl T's)

Where \* is a phosphorothioate internucleoside linkage, P- is a 5'-phosphate group, m is a 2'-O-methyl group and bold and underlined            is 2'-O-(CH<sub>2</sub>)<sub>2</sub>-OCH<sub>3</sub> modified nucleosides.

The activities are given for the 75 nM dose. The assay showed activity for most of the constructs examined with increased activity for the P=O/P=O full 2'-O-methyl construct with blunt ends.

**Example 9**

**Comparative study of 2'-O-Methyl constructs having P=O/P=O; P=O/P=S; P=S/P=O; and P=S/P=S linkage combinations**

The activities of constructs having all the different combinations of

5 P=O(S)/P=O(S) (2'-O-Methyl) were determined (% mRNA PTEN, normalized to Ribogreen, .6, 3, 15, and 75 nM doses). Activities are shown at the 75 nM dose. All sequences are 3'-dTdT.

	<u>ISIS NO's:</u>	<u>Description antisense/sense</u>	<u>PTEN mRNA Level</u>
10	N/A	Untreated control	1.00 (29597 site)
	297807/271788	P=O/P=O RNA	0.25
	344182/344181	P=S/P=S RNA	0.33
	297807/334470	P=O RNA/P=O 2'-O-CH <sub>3</sub>	0.22
	297807/344183	P=O RNA/P=S 2'-O-CH <sub>3</sub>	0.79
15	344182/334470	P=S RNA/P=O 2'-O-CH <sub>3</sub>	0.81
	344182/344183	P=S RNA/P=S 2'-O-CH <sub>3</sub>	0.69

	<u>SEQ ID NO:</u>	<u>ISIS NO:</u>	<u>Sequence 5'-3'</u>
			<b>(antisense sequences)</b>
20	16	297807	AUGAAGAAUGUAUUUACCC-dTdT
	16	344182	A*U*G*A*A*G*A*A*U*G*U*A*U*U*U*A*C*C*C*-dTdT
			<b>(sense sequences)</b>
	18	271788	GGGUAAAUACAUUCUUCAU-dTdT
	18	334470	G <sub>m</sub> G <sub>m</sub> G <sub>m</sub> U <sub>m</sub> A <sub>m</sub> A <sub>m</sub> A <sub>m</sub> U <sub>m</sub> A <sub>m</sub> C <sub>m</sub> A <sub>m</sub> U <sub>m</sub> U <sub>m</sub> C <sub>m</sub> U <sub>m</sub> U <sub>m</sub> C <sub>m</sub> A <sub>m</sub> U <sub>m</sub> -
25	dTdT 18	344181	G*G*G*U*A*A*A*U*A*C*A*U*U*C*U*U*C*A*U*-dTdT
	18	344183	G <sub>m</sub> *G <sub>m</sub> *G <sub>m</sub> *U <sub>m</sub> *A <sub>m</sub> *A <sub>m</sub> *A <sub>m</sub> *U <sub>m</sub> *A <sub>m</sub> *C <sub>m</sub> *A <sub>m</sub> *U <sub>m</sub> *U <sub>m</sub> *C <sub>m</sub> *U <sub>m</sub> *U <sub>m</sub> *C <sub>m</sub> *A <sub>m</sub> *U <sub>m</sub> *- C <sub>m</sub> *A <sub>m</sub> *U <sub>m</sub> *-dTdT

Where \* is a phosphorothioate internucleoside linkage, P- is a 5'-phosphate group  
30 and m is a 2'-O-methyl group.

Each of the constructs examined showed a dose response in the assay. The P=O/P=O 2'-O-methyl and the P=O/P=S 2'-O-methyl constructs showed comparable activity to the unmodified P=O/P=O in this assay.

**Example 10****siRNA constructs prepared and tested against eIF4E and Survivin targets**

Selected siRNA constructs were prepared and tested for their ability to lower targeted RNA as measured by RT-PCR. The IC<sub>50</sub> of each construct was determined.

5

**SEQ ID No: ISIS No: Constructs targeted to eIF4E (5'-3'):****Mixed 2'-F/2'-OCH<sub>3</sub> as/s RNA**

	25 (as) eIF4E	349890	UfGfUfCfAfUmAmUfUfCmCmUfGfGfAfUfCfCmUmUm
	26 (s) eIF4E	338935	AAGGAUCCAGGAAUAUGACA
10	27 (as) eIF4E	349891	UfCfCfUfGfGmAmUfCfCmUmUfCfAfCfCfAfAmUmGm
	28 (s) eIF4E	338939	CAUUGGUGAAGGAUCCAGGA
	29(as) eIF4E	349892	UfCfUfUfAfUmCmAfCfCmUmUfUfAfGfCfUfCmUmAm
	30 (s) eIF4E	338943	UAGAGCUAAAAGGUGAUAAGA
	31 (as) eIF4E	351097	AfUfAfCfUfCmAmGfAfAmGmGfUfGfUfCfUfUmCmUm
15	32 (s) eIF4E	338952	AGAAGACACCUUCUGAGUAU

**Full P=S RNA as/s full 2'-OCH<sub>3</sub>**

	35 (as) Survivin	346280	UrsUrsUrsGrsArsArsArsUrsGrsUrsUrsGrsArsUrsCrsUrsCrsCrsU
	34 (s) Survivin	352512	GmGmAmGmAmUmCmAmAmCmAmUmUmUmUmCmAmAmAm

**Full P=S RNA as/s full 2'-OCH<sub>3</sub> except terminal nucleosides**

20	35 (as) Survivin	346280	UrsUrsUrsGrsArsArsArsUrsGrsUrsUrsGrsArsUrsCrsUrsCrsCrsU
	34 (s) Survivin	352513	GGmAmGmAmUmCmAmAmCmAmUmUmUmUmCmAmAmA

**SEQ ID No: ISIS No: Constructs targeted to Survivin (5'-3'):****Mixed 2'-F/2'-OCH<sub>3</sub> as/s RNA**

25	33 (as) Survivin	355711	UfUfUfGfAfAmAmAfUfGmUmUfGfAfUfCfUmCmCm
	34 (s) Survivin	343868	GGAGAUCAACAUUUCAA

Lowercase f indicates that the preceding nucleoside is a 2'-F nucleoside (Cf=2'-F cytidine). Lowercase m indicates the previous nucleoside is a 2'-OCH<sub>3</sub> nucleoside.

30 Lowercase s (second lowercase letter following a U, A, G, or C) after a lowercase letter indicates that the internucleoside linkage is a phosphorothioate internucleoside linkage  
 'rs = the sugar is ribose and the internucleoside linkage is phosphorothioate.

The above constructs were tested in HeLa cells, MH-S cells or U-87 MG cells using a standard assay as shown in Example 15. The IC<sub>50</sub>'s were calculated as shown

35 below.

	<u>SEQ ID No/Construct</u>	<u>Species/cell line</u>	<u>Gene</u>	<u>IC<sub>50</sub></u>
	(antisense:sense)			
	25:26/ 349890:338935	Human/HeLa	eIF4E	0.17
	25:26/ 349890:338935	Mouse/MH-S/Mouse	eIF4E	0.026477
5	27:28/ 349891:338939	Human/HeLa	eIF4E	0.276
	27:28/ 349891:338939	Mouse/MH-S/Mouse	eIF4E	0.095493
	29:30/ 349892:338943	Human/HeLa	eIF4E	0.12
	29:30/ 349892:338943	Mouse/MH-S/Mouse	eIF4E	0.0621
	31:32/ 351097:338952	Human/HeLa	eIF4E	0.748
10	31:32/ 351097:338952	Mouse/MH-S/Mouse	eIF4E	0.038093
	33:34/ 355711:343868	Human/HeLa	Survivin	0.021959
	35:34/ 346280:352512	Human/HeLa	Survivin	1.0965
	35:34/ 346280:352513	Human/HeLa	Survivin	1.8588.

## 15 Example 11

### Synthesis of Nucleoside Phosphoramidites

The following compounds, including amidites and their intermediates were prepared as described in US Patent 6,426,220 and published PCT WO 02/36743; 5'-O-Dimethoxytrityl-thymidine intermediate for 5-methyl dC amidite, 5'-O-Dimethoxytrityl-2'-deoxy-5-methylcytidine intermediate for 5-methyl-dC amidite, 5'-O-Dimethoxytrityl-2'-deoxy-N<sup>4</sup>-benzoyl-5-methylcytidine penultimate intermediate for 5-methyl dC amidite, [5'-O-(4,4'-Dimethoxytriphenylmethyl)-2'-deoxy-N<sup>4</sup>-benzoyl-5-methylcytidin-3'-O-yl]-2-cyanoethyl-*N,N*-diisopropylphosphoramidite (5-methyl dC amidite), 2'-Fluorodeoxyadenosine, 2'-Fluorodeoxyguanosine, 2'-Fluorouridine, 2'-Fluorodeoxycytidine, 2'-O-(2-Methoxyethyl) modified amidites, 2'-O-(2-methoxyethyl)-5-methyluridine intermediate, 5'-O-DMT-2'-O-(2-methoxyethyl)-5-methyluridine penultimate intermediate, [5'-O-(4,4'-Dimethoxytriphenylmethyl)-2'-O-(2-methoxyethyl)-5-methyluridin-3'-O-yl]-2-cyanoethyl-*N,N*-diisopropylphosphoramidite (MOE T amidite), 5'-O-Dimethoxytrityl-2'-O-(2-methoxyethyl)-5-methylcytidine intermediate, 5'-O-dimethoxytrityl-2'-O-(2-methoxyethyl)-N<sup>4</sup>-benzoyl-5-methyl-cytidine penultimate intermediate, [5'-O-(4,4'-Dimethoxytriphenylmethyl)-2'-O-(2-methoxyethyl)-N<sup>4</sup>-benzoyl-5-methylcytidin-3'-O-yl]-2-cyanoethyl-*N,N*-diisopropylphosphoramidite (MOE 5-Me-C amidite), [5'-O-(4,4'-Dimethoxytriphenylmethyl)-2'-O-(2-methoxyethyl)-N<sup>6</sup>-benzoyladenoin-3'-O-yl]-2-cyanoethyl-*N,N*-diisopropylphosphoramidite (MOE A amidite), [5'-O-(4,4'-Dimethoxytriphenylmethyl)-2'-O-(2-methoxyethyl)-N<sup>4</sup>-isobutyrylguanoin-3'-O-yl]-2-

cyanoethyl-*N,N*-diisopropylphosphoramidite (MOE G amidite), 2'-O-(Aminoxyethyl) nucleoside amidites and 2'-O-(dimethylaminoxyethyl) nucleoside amidites, 2'-(Dimethylaminoxyethoxy) nucleoside amidites, 5'-O-*tert*-Butyldiphenylsilyl-O<sup>2</sup>-2'-anhydro-5-methyluridine, 5'-O-*tert*-Butyldiphenylsilyl-2'-O-(2-hydroxyethyl)-5-methyluridine, 2'-O-([2-phthalimidoxy)ethyl]-5'-*t*-butyldiphenylsilyl-5-methyluridine, 5'-O-*tert*-butyldiphenylsilyl-2'-O-[(2-formadoximinoxy)ethyl]-5-methyluridine, 5'-O-*tert*-Butyldiphenylsilyl-2'-O-[*N,N* dimethylaminoxyethyl]-5-methyluridine, 2'-O-(dimethylaminoxyethyl)-5-methyluridine, 5'-O-DMT-2'-O-(dimethylaminoxyethyl)-5-methyluridine, 5'-O-DMT-2'-O-(2-*N,N*-dimethylaminoxyethyl)-5-methyluridine-3'-[(2-cyanoethyl)-*N,N*-diisopropylphosphoramidite], 2'-(Aminoxyethoxy) nucleoside amidites, *N*2-isobutyryl-6-O-diphenylcarbonyl-2'-O-(2-ethylacetyl)-5'-O-(4,4'-dimethoxytrityl)guanosine-3'-[(2-cyanoethyl)-*N,N*-diisopropylphosphoramidite], 2'-dimethylaminoethoxyethoxy (2'-DMAEOE) nucleoside amidites, 2'-O-[2(2-*N,N*-dimethylaminoethoxy)ethyl]-5-methyl uridine, 5'-O-dimethoxytrityl-2'-O-[2(2-*N,N*-dimethylaminoethoxy)-ethyl]-5-methyl uridine and 5'-O-Dimethoxytrityl-2'-O-[2(2-*N,N*-dimethylaminoethoxy)-ethyl]-5-methyl uridine-3'-O-(cyanoethyl-*N,N*-diisopropyl)phosphoramidite.

### Example 12

#### 20 Oligonucleotide and oligonucleoside synthesis

The oligomeric compounds used in accordance with this invention may be conveniently and routinely made through the well-known technique of solid phase synthesis. Equipment for such synthesis is sold by several vendors including, for example, Applied Biosystems (Foster City, CA). Any other means for such synthesis  
25 known in the art may additionally or alternatively be employed. It is well known to use similar techniques to prepare oligonucleotides such as the phosphorothioates and alkylated derivatives.

Oligonucleotides: Unsubstituted and substituted phosphodiester (P=O) oligonucleotides are synthesized on an automated DNA synthesizer (Applied Biosystems  
30 model 394) using standard phosphoramidite chemistry with oxidation by iodine.

Phosphorothioates (P=S) are synthesized similar to phosphodiester oligonucleotides with the following exceptions: thiation was effected by utilizing a 10% w/v solution of 3,4-dihydro-2H-benzothiole-3-one 1,1-dioxide in acetonitrile for the oxidation of the phosphite linkages. The thiation reaction step time was increased to 180 sec and

preceded by the normal capping step. After cleavage from the CPG column and deblocking in concentrated ammonium hydroxide at 55°C (12-16 hr), the oligonucleotides were recovered by precipitating with >3 volumes of ethanol from a 1 M NH<sub>4</sub>OAc solution. Phosphinate oligonucleotides are prepared as described in U.S.

5 Patent 5,508,270, herein incorporated by reference.

Alkyl phosphonate oligonucleotides are prepared as described in U.S. Patent 4,469,863, herein incorporated by reference.

3'-Deoxy-3'-methylene phosphonate oligonucleotides are prepared as described in U.S. Patents 5,610,289 or 5,625,050, herein incorporated by reference.

10 Phosphoramidite oligonucleotides are prepared as described in U.S. Patent, 5,256,775 or U.S. Patent 5,366,878, herein incorporated by reference.

Alkylphosphonothioate oligonucleotides are prepared as described in published PCT applications PCT/US94/00902 and PCT/US93/06976 (published as WO 94/17093 and WO 94/02499, respectively), herein incorporated by reference.

15 3'-Deoxy-3'-amino phosphoramidate oligonucleotides are prepared as described in U.S. Patent 5,476,925, herein incorporated by reference.

Phosphotriester oligonucleotides are prepared as described in U.S. Patent 5,023,243, herein incorporated by reference.

20 Borano phosphate oligonucleotides are prepared as described in U.S. Patents 5,130,302 and 5,177,198, both herein incorporated by reference.

Oligonucleosides: Methylenemethylimino linked oligonucleosides, also identified as MMI linked oligonucleosides, methylenedimethylhydrazo linked oligonucleosides, also identified as MDH linked oligonucleosides, and methylenecarbonylamino linked oligonucleosides, also identified as amide-3 linked oligonucleosides, and  
25 methyleneaminocarbonyl linked oligonucleosides, also identified as amide-4 linked oligonucleosides, as well as mixed backbone oligomeric compounds having, for instance, alternating MMI and P=O or P=S linkages are prepared as described in U.S. Patents 5,378,825, 5,386,023, 5,489,677, 5,602,240 and 5,610,289, all of which are herein incorporated by reference.

30 Formacetal and thioformacetal linked oligonucleosides are prepared as described in U.S. Patents 5,264,562 and 5,264,564, herein incorporated by reference.

Ethylene oxide linked oligonucleosides are prepared as described in U.S. Patent 5,223,618, herein incorporated by reference.



**Example 13****RNA Synthesis**

In general, RNA synthesis chemistry is based on the selective incorporation of various protecting groups at strategic intermediary reactions. Although one of ordinary skill in the art will understand the use of protecting groups in organic synthesis, a useful class of protecting groups includes silyl ethers. In particular bulky silyl ethers are used to protect the 5'-hydroxyl in combination with an acid-labile orthoester protecting group on the 2'-hydroxyl. This set of protecting groups is then used with standard solid-phase synthesis technology. It is important to lastly remove the acid labile orthoester protecting group after all other synthetic steps. Moreover, the early use of the silyl protecting groups during synthesis ensures facile removal when desired, without undesired deprotection of 2' hydroxyl.

Following this procedure for the sequential protection of the 5'-hydroxyl in combination with protection of the 2'-hydroxyl by protecting groups that are differentially removed and are differentially chemically labile, RNA oligonucleotides were synthesized.

RNA oligonucleotides are synthesized in a stepwise fashion. Each nucleotide is added sequentially (3'- to 5'-direction) to a solid support-bound oligonucleotide. The first nucleoside at the 3'-end of the chain is covalently attached to a solid support. The nucleotide precursor, a ribonucleoside phosphoramidite, and activator are added, coupling the second base onto the 5'-end of the first nucleoside. The support is washed and any unreacted 5'-hydroxyl groups are capped with acetic anhydride to yield 5'-acetyl moieties. The linkage is then oxidized to the more stable and ultimately desired P(V) linkage. At the end of the nucleotide addition cycle, the 5'-silyl group is cleaved with fluoride. The cycle is repeated for each subsequent nucleotide.

Following synthesis, the methyl protecting groups on the phosphates are cleaved in 30 minutes utilizing 1 M disodium-2-carbamoyl-2-cyanoethylene-1,1-dithiolate trihydrate ( $S_2Na_2$ ) in DMF. The deprotection solution is washed from the solid support-bound oligonucleotide using water. The support is then treated with 40% methylamine in water for 10 minutes at 55 °C. This releases the RNA oligonucleotides into solution, deprotects the exocyclic amines, and modifies the 2'-groups. The oligonucleotides can be analyzed by anion exchange HPLC at this stage.

The 2'-orthoester groups are the last protecting groups to be removed. The ethylene glycol monoacetate orthoester protecting group developed by Dharmacon Research, Inc. (Lafayette, CO), is one example of a useful orthoester protecting group which, has the following important properties. It is stable to the conditions of nucleoside  
5 phosphoramidite synthesis and oligonucleotide synthesis. However, after oligonucleotide synthesis the oligonucleotide is treated with methylamine which not only cleaves the oligonucleotide from the solid support but also removes the acetyl groups from the orthoesters. The resulting 2-ethyl-hydroxyl substituents on the orthoester are less electron withdrawing than the acetylated precursor. As a result, the modified  
10 orthoester becomes more labile to acid-catalyzed hydrolysis. Specifically, the rate of cleavage is approximately 10 times faster after the acetyl groups are removed. Therefore, this orthoester possesses sufficient stability in order to be compatible with oligonucleotide synthesis and yet, when subsequently modified, permits deprotection to be carried out under relatively mild aqueous conditions compatible with the final RNA  
15 oligonucleotide product.

Additionally, methods of RNA synthesis are well known in the art (Scaringe, S. A. Ph.D. Thesis, University of Colorado, 1996; Scaringe, S. A., et al., *J. Am. Chem. Soc.*, **1998**, *120*, 11820-11821; Matteucci, M. D. and Caruthers, M. H. *J. Am. Chem. Soc.*, **1981**, *103*, 3185-3191; Beaucage, S. L. and Caruthers, M. H. *Tetrahedron Lett.*, **1981**,  
20 *22*, 1859-1862; Dahl, B. J., et al., *Acta Chem. Scand.*, **1990**, *44*, 639-641; Reddy, M. P., et al., *Tetrahedron Lett.*, **1994**, *25*, 4311-4314; Wincott, F. et al., *Nucleic Acids Res.*, **1995**, *23*, 2677-2684; Griffin, B. E., et al., *Tetrahedron*, **1967**, *23*, 2301-2313; Griffin, B. E., et al., *Tetrahedron*, **1967**, *23*, 2315-2331).

RNA antisense oligomeric compounds (RNA oligonucleotides) of the present  
25 invention can be synthesized by the methods herein or purchased from Dharmacon Research, Inc (Lafayette, CO). Once synthesized, complementary RNA antisense oligomeric compounds can then be annealed by methods known in the art to form double stranded (duplexed) antisense oligomeric compounds. For example, duplexes can be formed by combining 30  $\mu$ l of each of the complementary strands of RNA  
30 oligonucleotides (50  $\mu$ M RNA oligonucleotide solution) and 15  $\mu$ l of 5X annealing buffer (100 mM potassium acetate, 30 mM HEPES-KOH pH 7.4, 2 mM magnesium acetate) followed by heating for 1 minute at 90°C, then 1 hour at 37°C. The resulting duplexed antisense oligomeric compounds can be used in kits, assays, screens, or other methods to investigate the role of a target nucleic acid.

**Example 14****Synthesis of Chimeric Oligonucleotides**

Chimeric oligonucleotides, oligonucleosides or mixed

5 oligonucleotides/oligonucleosides of the invention can be of several different types. These include a first type wherein the "gap" segment of linked nucleosides is positioned between 5' and 3' "wing" segments of linked nucleosides and a second "open end" type wherein the "gap" segment is located at either the 3' or the 5' terminus of the oligomeric compound. Oligonucleotides of the first type are also known in the art as "gapmers" or  
 10 gapped oligonucleotides. Oligonucleotides of the second type are also known in the art as "hemimers" or "wingmers".

**[2'-O-Me]--[2'-deoxy]--[2'-O-Me] Chimeric Phosphorothioate  
 Oligonucleotides**

Chimeric oligonucleotides having 2'-O-alkyl phosphorothioate and 2'-deoxy  
 15 phosphorothioate oligonucleotide segments are synthesized using an Applied Biosystems automated DNA synthesizer Model 394, as above. Oligonucleotides are synthesized using the automated synthesizer and 2'-deoxy-5'-dimethoxytrityl-3'-O-phosphoramidite for the DNA portion and 5'-dimethoxytrityl-2'-O-methyl-3'-O-phosphoramidite for 5' and  
 20 3' wings. The standard synthesis cycle is modified by incorporating coupling steps with increased reaction times for the 5'-dimethoxytrityl-2'-O-methyl-3'-O-phosphoramidite. The fully protected oligonucleotide is cleaved from the support and deprotected in concentrated ammonia (NH<sub>4</sub>OH) for 12-16 hr at 55°C. The deprotected oligo is then  
 25 recovered by an appropriate method (precipitation, column chromatography, volume reduced *in vacuo* and analyzed spectrophotometrically for yield and for purity by capillary electrophoresis and by mass spectrometry.

**[2'-O-(2-Methoxyethyl)]--[2'-deoxy]--[2'-O-(Methoxyethyl)] Chimeric  
 Phosphorothioate Oligonucleotides**

[2'-O-(2-methoxyethyl)]--[2'-deoxy]--[2'-O-(methoxyethyl)] chimeric  
 phosphorothioate oligonucleotides were prepared as per : procedure above for the 2'-  
 30 O-methyl chimeric oligonucleotide, with the substitution of 2'-O-(methoxyethyl) amidites for the 2'-O-methyl amidites.

**[2'-O-(2-Methoxyethyl)Phosphodiester]--[2'-deoxy Phosphorothioate]--[2'-O-(2-Methoxyethyl) Phosphodiester] Chimeric Oligonucleotides**

[2'-O-(2-methoxyethyl phosphodiester)--[2'-deoxy phosphorothioate]--[2'-O-(methoxyethyl) phosphodiester] chimeric oligonucleotides are prepared as per the above procedure for the 2'-O-methyl chimeric oligonucleotide with the substitution of 2'-O-(methoxyethyl) amidites for the 2'-O-methyl amidites, oxidation with iodine to generate the phosphodiester internucleotide linkages within the wing portions of the chimeric structures and sulfurization utilizing 3,4-dihydro-2H-benzothiole-3-one 1,1-dioxide (Beaucage Reagent) to generate the phosphorothioate internucleotide linkages for the center gap.

Other chimeric oligonucleotides, chimeric oligonucleosides and mixed chimeric oligonucleotides/oligonucleosides are synthesized according to United States patent 5,623,065, herein incorporated by reference.

**Example 15**

**Design and screening of duplexed antisense oligomeric compounds directed to a selected target**

In accordance with the present invention, a series of nucleic acid duplexes comprising the antisense oligomeric compounds of the present invention and their complements can be designed to target a target. The ends of the strands may be modified by the addition of one or more natural or modified nucleobases to form an overhang. The sense strand of the dsRNA is then designed and synthesized as the complement of the antisense strand and may also contain modifications or additions to either terminus. For example, in one embodiment, both strands of the dsRNA duplex would be complementary over the central nucleobases, each having overhangs at one or both termini.

For example, a duplex comprising an antisense strand having the sequence CGAGAGGCGGACGGGACCG and having a two-nucleobase overhang of deoxythymidine(dT) would have the following structure:



RNA strands of the duplex can be synthesized by methods disclosed herein or purchased from Dharmacon Research Inc., (Lafayette, CO). Once synthesized, the complementary strands are annealed. The single strands are aliquoted and diluted to a concentration of 50 uM. Once diluted, 30 uL of each strand is combined with 15uL of a

5X solution of annealing buffer. The final concentration of said buffer is 100 mM potassium acetate, 30 mM HEPES-KOH pH 7.4, and 2mM magnesium acetate. The final volume is 75 uL. This solution is incubated for 1 minute at 90°C and then centrifuged for 15 seconds. The tube is allowed to sit for 1 hour at 37°C at which time  
5 the dsRNA duplexes are used in experimentation. The final concentration of the dsRNA duplex is 20 uM. This solution can be stored frozen (-20°C) and freeze-thawed up to 5 times.

Once prepared, the duplexed antisense oligomeric compounds are evaluated for their ability to modulate a target expression.

10 When cells reached 80% confluency, they are treated with duplexed antisense oligomeric compounds of the invention. For cells grown in 96-well plates, wells are washed once with 200 µL OPTI-MEM-1 reduced-serum medium (Gibco BRL) and then treated with 130 µL of OPTI-MEM-1 containing 12 µg/mL LIPOFECTIN (Gibco BRL) and the desired duplex antisense oligomeric compound at a final concentration of 200  
15 nM. After 5 hours of treatment, the medium is replaced with fresh medium. Cells are harvested 16 hours after treatment, at which time RNA is isolated and target reduction measured by RT-PCR.

### Example 16

#### 20 Oligonucleotide Isolation

After cleavage from the controlled pore glass solid support and deblocking in concentrated ammonium hydroxide at 55°C for 12-16 hours, the oligonucleotides or oligonucleosides are recovered by precipitation out of 1 M NH<sub>4</sub>OAc with >3 volumes of ethanol. Synthesized oligonucleotides were analyzed by electrospray mass spectroscopy  
25 (molecular weight determination) and by capillary gel electrophoresis and judged to be at least 70% full length material. The relative amounts of phosphorothioate and phosphodiester linkages obtained in the synthesis was determined by the ratio of correct molecular weight relative to the -16 amu product (+/-32 +/-48). For some studies

igonucleotides were purified by HPLC, as described by Chiang *et al.*, *J. Bio Chem.*  
30 **1991**, 266, 18162-18171. Results obtained with HPLC-purified material were similar to those obtained with non-HPLC purified material.

### Example 17

### Oligonucleotide Synthesis - 96 Well Plate Format

Oligonucleotides were synthesized via solid phase P(III) phosphoramidite chemistry on an automated synthesizer capable of assembling 96 sequences simultaneously in a 96-well format. Phosphodiester internucleotide linkages were afforded by oxidation with aqueous iodine. Phosphorothioate internucleotide linkages were generated by sulfurization utilizing 3,4-dihydro-2H-benzothio-3-one 1,1-dioxide (Beaucage Reagent) in anhydrous acetonitrile. Standard base-protected beta-cyanoethyl-diisopropyl phosphoramidites were purchased from commercial vendors (e.g. PE-Applied Biosystems, Foster City, CA, or Pharmacia, Piscataway, NJ). Non-standard nucleosides are synthesized as per standard or patented methods. They are utilized as base protected beta-cyanoethyl-diisopropyl phosphoramidites.

Oligonucleotides were cleaved from support and deprotected with concentrated  $\text{NH}_4\text{OH}$  at elevated temperature (55-60°C) for 12-16 hours and the released product then dried *in vacuo*. The dried product was then re-suspended in sterile water to afford a master plate from which all analytical and test plate samples are then diluted utilizing robotic pipettors.

### Example 18

#### Oligonucleotide Analysis using 96-Well Plate Format

The concentration of oligonucleotide in each well was assessed by dilution of samples and UV absorption spectroscopy. The full-length integrity of the individual products was evaluated by capillary electrophoresis (CE) in either the 96-well format (Beckman P/ACE™ MDQ) or, for individually prepared samples, on a commercial CE apparatus (e.g., Beckman P/ACE™ 5000, ABI 270). Base and backbone composition was confirmed by mass analysis of the oligomeric compounds utilizing electrospray-mass spectroscopy. All assay test plates were diluted from the master plate using single and multi-channel robotic pipettors. Plates were judged to be acceptable if at least 85% of the oligomeric compounds on the plate were at least 85% full length.

### Example 19

#### Cell culture and oligonucleotide treatment

The effect of oligomeric compounds on target nucleic acid expression can be tested in any of a variety of cell types provided that the target nucleic acid is present at

measurable levels. This can be routinely determined using, for example, PCR or Northern blot analysis. The following cell types are provided for illustrative purposes, but other cell types can be routinely used, provided that the target is expressed in the cell type chosen. This can be readily determined by methods routine in the art, for example

5 Northern blot analysis, ribonuclease protection assays, or RT-PCR.

T-24 cells:

The human transitional cell bladder carcinoma cell line T-24 was obtained from the American Type Culture Collection (ATCC) (Manassas, VA). T-24 cells were routinely cultured in complete McCoy's 5A basal media (Invitrogen Corporation,

10 Carlsbad, CA) supplemented with 10% fetal calf serum (Invitrogen Corporation, Carlsbad, CA), penicillin 100 units per mL, and streptomycin 100 micrograms per mL (Invitrogen Corporation, Carlsbad, CA). Cells were routinely passaged by trypsinization and dilution when they reached 90% confluence. Cells were seeded into 96-well plates (Falcon-Primaria #353872) at a density of 7000 cells/well for use in RT-PCR analysis.

15 For Northern blotting or other analysis, cells may be seeded onto 100 mm or other standard tissue culture plates and treated similarly, using appropriate volumes of medium and oligonucleotide.

A549 cells:

The human lung carcinoma cell line A549 was obtained from the American Type

20 Culture Collection (ATCC) (Manassas, VA). A549 cells were routinely cultured in DMEM basal media (Invitrogen Corporation, Carlsbad, CA) supplemented with 10% fetal calf serum (Invitrogen Corporation, Carlsbad, CA), penicillin 100 units per mL, and streptomycin 100 micrograms per mL (Invitrogen Corporation, Carlsbad, CA). Cells were routinely passaged by trypsinization and dilution when they reached 90%

25 confluence.

NHDF cells:

Human neonatal dermal fibroblast (NHDF) were obtained from the Clonetics Corporation (Walkersville, MD). NHDFs were routinely maintained in Fibroblast Growth Medium (Clonetics Corporation, Walkersville, MD) supplemented as

30 recommended by the supplier. Cells were maintained for up to 10 passages as recommended by the supplier.

HEK cells:

Human embryonic keratinocytes (HEK) were obtained from the Clonetics Corporation (Walkersville, MD). HEKs were routinely maintained in Keratinocyte

Growth Medium (Clonetics Corporation, Walkersville, MD) formulated as recommended by the supplier. Cells were routinely maintained for up to 10 passages as recommended by the supplier.

Treatment with oligomeric compounds:

5           When cells reached 65-75% confluency, they were treated with oligonucleotide. For cells grown in 96-well plates, wells were washed once with 100  $\mu$ L OPTI-MEM™-1 reduced-serum medium (Invitrogen Corporation, Carlsbad, CA) and then treated with 130  $\mu$ L of OPTI-MEM™-1 containing 3.75  $\mu$ g/mL LIPOFECTIN™ (Invitrogen Corporation, Carlsbad, CA) and the desired concentration of oligonucleotide. Cells are  
10 treated and data are obtained in triplicate. After 4-7 hours of treatment at 37°C, the medium was replaced with fresh medium. Cells were harvested 16-24 hours after oligonucleotide treatment.

          The concentration of oligonucleotide used varies from cell line to cell line. To determine the optimal oligonucleotide concentration for a particular cell line, the cells  
15 are treated with a positive control oligonucleotide at a range of concentrations. For human cells the positive control oligonucleotide is selected from either ISIS 13920 (TCCGTCATCGCTCCTCAGGG, SEQ ID NO: 12) which is targeted to human H-ras, or ISIS 18078, (GTGCGCGCGAGCCCGAAATC, SEQ ID NO: 13) which is targeted to human Jun-N-terminal kinase-2 (JNK2). Both controls are 2'-O-methoxyethyl  
20 gapmers (2'-O-methoxyethyls shown in bold) with a phosphorothioate backbone. For mouse or rat cells the positive control oligonucleotide is ISIS 15770, ATGCATTCTGC-CCCCAAGGA, SEQ ID NO: 14, a 2'-O-methoxyethyl gapmer (2'-O-methoxyethyls shown in bold) with a phosphorothioate backbone which is targeted to both mouse and rat c-raf. The concentration of positive control oligonucleotide that results in 80%  
25 inhibition of c-H-ras (for ISIS 13920), JNK2 (for ISIS 18078) or c-raf (for ISIS 15770) mRNA is then utilized as the screening concentration for new oligonucleotides in subsequent experiments for that cell line. If 80% inhibition is not achieved, the lowest concentration of positive control oligonucleotide that results in 60% inhibition of c-H-ras, JNK2 or c-raf mRNA is then utilized as the oligonucleotide screening concentration  
30 in subsequent experiments for that cell line. If 60% inhibition is not achieved, that particular cell line is deemed as unsuitable for oligonucleotide transfection experiments. The concentrations of antisense oligonucleotides used herein are from 50 nM to 300 nM.



**Example 20****Analysis of oligonucleotide inhibition of a target expression**

Antisense modulation of a target expression can be assayed in a variety of ways known in the art. For example, a target mRNA levels can be quantitated by, e.g.,

5 Northern blot analysis, competitive polymerase chain reaction (PCR), or real-time PCR (RT-PCR). Real-time quantitative PCR is presently preferred. RNA analysis can be performed on total cellular RNA or poly(A)+ mRNA. The preferred method of RNA analysis of the present invention is the use of total cellular RNA as described in other examples herein. Methods of RNA isolation are well known in the art. Northern blot

10 analysis is also routine in the art. Real-time quantitative (PCR) can be conveniently accomplished using the commercially available ABI PRISM™ 7600, 7700, or 7900 Sequence Detection System, available from PE-Applied Biosystems, Foster City, CA and used according to manufacturer's instructions.

Protein levels of a target can be quantitated in a variety of ways well known in

15 the art, such as immunoprecipitation, Western blot analysis (immunoblotting), enzyme-linked immunosorbent assay (ELISA) or fluorescence-activated cell sorting (FACS). Antibodies directed to a target can be identified and obtained from a variety of sources, such as the MSRS catalog of antibodies (Aerie Corporation, Birmingham, MI), or can be prepared via conventional monoclonal or polyclonal antibody generation methods well

20 known in the art.

**Example 21****Design of phenotypic assays and *in vivo* studies for the use of a target inhibitors****25 Phenotypic assays**

Once a target inhibitors have been identified by the methods disclosed herein, the oligomeric compounds are further investigated in one or more phenotypic assays, each having measurable endpoints predictive of efficacy in the treatment of a particular disease state or condition.

30 Phenotypic assays, kits and reagents for their use are well known to those skilled in the art and are herein used to investigate the role and/or association of a target in health and disease. Representative phenotypic assays, which can be purchased from any one of several commercial vendors, include those for determining cell viability,

cytotoxicity, proliferation or cell survival (Molecular Probes, Eugene, OR; PerkinElmer, Boston, MA), protein-based assays including enzymatic assays (Panvera, LLC, Madison, WI; BD Biosciences, Franklin Lakes, NJ; Oncogene Research Products, San Diego, CA), cell regulation, signal transduction, inflammation, oxidative processes and apoptosis (Assay Designs Inc., Ann Arbor, MI), triglyceride accumulation (Sigma-Aldrich, St. Louis, MO), angiogenesis assays, tube formation assays, cytokine and hormone assays and metabolic assays (Chemicon International Inc., Temecula, CA; Amersham Biosciences, Piscataway, NJ).

In one non-limiting example, cells determined to be appropriate for a particular phenotypic assay (i.e., MCF-7 cells selected for breast cancer studies; adipocytes for obesity studies) are treated with a target inhibitors identified from the *in vitro* studies as well as control compounds at optimal concentrations which are determined by the methods described above. At the end of the treatment period, treated and untreated cells are analyzed by one or more methods specific for the assay to determine phenotypic outcomes and endpoints.

Phenotypic endpoints include changes in cell morphology over time or treatment dose as well as changes in levels of cellular components such as proteins, lipids, nucleic acids, hormones, saccharides or metals. Measurements of cellular status which include pH, stage of the cell cycle, intake or excretion of biological indicators by the cell, are also endpoints of interest.

Analysis of the genotype of the cell (measurement of the expression of one or more of the genes of the cell) after treatment is also used as an indicator of the efficacy or potency of the a target inhibitors. Hallmark genes, or those genes suspected to be associated with a specific disease state, condition, or phenotype, are measured in both treated and untreated cells.

#### **In vivo studies**

The individual subjects of the *in vivo* studies described herein are warm-blooded vertebrate animals, which includes humans.

The clinical trial is subjected to rigorous controls to ensure that individuals are not unnecessarily put at risk and that they are fully informed about their role in the study.

To account for the psychological effects of receiving treatments, volunteers are randomly given placebo or a target inhibitor. Furthermore, to prevent the doctors from being biased in treatments, they are not informed as to whether the medication they are administering is a a target inhibitor or a placebo. Using this randomization approach,

each volunteer has the same chance of being given either the new treatment or the placebo.

Volunteers receive either the a target inhibitor or placebo for eight week period with biological parameters associated with the indicated disease state or condition being measured at the beginning (baseline measurements before any treatment), end (after the final treatment), and at regular intervals during the study period. Such measurements include the levels of nucleic acid molecules encoding a target or a target protein levels in body fluids, tissues or organs compared to pre-treatment levels. Other measurements include, but are not limited to, indices of the disease state or condition being treated, body weight, blood pressure, serum titers of pharmacologic indicators of disease or toxicity as well as ADME (absorption, distribution, metabolism and excretion) measurements.

Information recorded for each patient includes age (years), gender, height (cm), family history of disease state or condition (yes/no), motivation rating (some/moderate/great) and number and type of previous treatment regimens for the indicated disease or condition.

Volunteers taking part in this study are healthy adults (age 18 to 65 years) and roughly an equal number of males and females participate in the study. Volunteers with certain characteristics are equally distributed for placebo and a target inhibitor treatment. In general, the volunteers treated with placebo have little or no response to treatment, whereas the volunteers treated with the a target inhibitor show positive trends in their disease state or condition index at the conclusion of the study.

## **Example 22**

### **25 RNA Isolation**

#### **Poly(A)+ mRNA isolation**

Poly(A)+ mRNA was isolated according to Miura *et al.*, (*Clin. Chem.*, 1996, 42, 1758-1764). Other methods for poly(A)+ mRNA isolation are routine in the art. Briefly, for cells grown on 96-well plates, growth medium was removed from the cells and each well was washed with 200  $\mu$ L cold PBS. 60  $\mu$ L lysis buffer (10 mM Tris-HCl, pH 7.6, 1 mM EDTA, 0.5 M NaCl, 0.5% NP-40, 20 mM vanadyl-ribonucleoside complex) was added to each well, the plate was gently agitated and then incubated at room temperature for five minutes. 55  $\mu$ L of lysate was transferred to Oligo d(T) coated 96-well plates

(AGCT Inc., Irvine CA). Plates were incubated for 60 minutes at room temperature, washed 3 times with 200  $\mu$ L of wash buffer (10 mM Tris-HCl pH 7.6, 1 mM EDTA, 0.3 M NaCl). After the final wash, the plate was blotted on paper towels to remove excess wash buffer and then air-dried for 5 minutes. 60  $\mu$ L of elution buffer (5 mM Tris-HCl pH 7.6), preheated to 70°C, was added to each well, the plate was incubated on a 90°C hot plate for 5 minutes, and the eluate was then transferred to a fresh 96-well plate.

Cells grown on 100 mm or other standard plates may be treated similarly, using appropriate volumes of all solutions.

#### *Total RNA Isolation*

10 Total RNA was isolated using an RNEASY 96™ kit and buffers purchased from Qiagen Inc. (Valencia, CA) following the manufacturer's recommended procedures. Briefly, for cells grown on 96-well plates, growth medium was removed from the cells and each well was washed with 200  $\mu$ L cold PBS. 150  $\mu$ L Buffer RLT was added to each well and the plate vigorously agitated for 20 seconds. 150  $\mu$ L of 70% ethanol was then added to each well and the contents  
15 mixed by pipetting three times up and down. The samples were then transferred to the RNEASY 96™ well plate attached to a QIAVAC™ manifold fitted with a waste collection tray and attached to a vacuum source. Vacuum was applied for 1 minute. 500  $\mu$ L of Buffer RW1 was added to each well of the RNEASY 96™ plate and incubated for 15 minutes and the vacuum was again applied for 1 minute. An additional 500  $\mu$ L of Buffer RW1 was added to  
20 each well of the RNEASY 96™ plate and the vacuum was applied for 2 minutes. 1 mL of Buffer RPE was then added to each well of the RNEASY 96™ plate and the vacuum applied for a period of 90 seconds. The Buffer RPE wash was then repeated and the vacuum was applied for an additional 3 minutes. The plate was then removed from the QIAVAC™ manifold and blotted dry on paper towels. The plate was then re-attached to the QIAVAC™ manifold fitted with a  
25 collection tube rack containing 1.2 mL collection tubes. RNA was then eluted by pipetting 140  $\mu$ L of RNase free water into each well, incubating 1 minute, and then applying the vacuum for 3 minutes.

The repetitive pipetting and elution steps may be automated using a QIAGEN Bio-Robot 9604 (Qiagen, Inc., Valencia CA). Essentially, after lysing of the cells on the  
30 culture plate, the plate is transferred to the robot deck where the pipetting, DNase treatment and elution steps are carried out.

#### **Example 23**

### Real-time Quantitative PCR Analysis of a target mRNA Levels

Quantitation of a target mRNA levels was accomplished by real-time quantitative PCR using the ABI PRISM™ 7600, 7700, or 7900 Sequence Detection System (PE-Applied Biosystems, Foster City, CA) according to manufacturer's instructions. This is a closed-tube, non-gel-based, fluorescence detection system which allows high-throughput quantitation of polymerase chain reaction (PCR) products in real-time. As opposed to standard PCR in which amplification products are quantitated after the PCR is completed, products in real-time quantitative PCR are quantitated as they accumulate. This is accomplished by including in the PCR reaction an oligonucleotide probe that anneals specifically between the forward and reverse PCR primers, and contains two fluorescent dyes. A reporter dye (e.g., FAM or JOE, obtained from either PE-Applied Biosystems, Foster City, CA, Operon Technologies Inc., Alameda, CA or Integrated DNA Technologies Inc., Coralville, IA) is attached to the 5' end of the probe and a quencher dye (e.g., TAMRA, obtained from either PE-Applied Biosystems, Foster City, CA, Operon Technologies Inc., Alameda, CA or Integrated DNA Technologies Inc., Coralville, IA) is attached to the 3' end of the probe. When the probe and dyes are intact, reporter dye emission is quenched by the proximity of the 3' quencher dye. During amplification, annealing of the probe to the target sequence creates a substrate that can be cleaved by the 5'-exonuclease activity of Taq polymerase. During the extension phase of the PCR amplification cycle, cleavage of the probe by Taq polymerase releases the reporter dye from the remainder of the probe (and hence from the quencher moiety) and a sequence-specific fluorescent signal is generated. With each cycle, additional reporter dye molecules are cleaved from their respective probes, and the fluorescence intensity is monitored at regular intervals by laser optics built into the ABI PRISM™ Sequence Detection System. In each assay, a series of parallel reactions containing serial dilutions of mRNA from untreated control samples generates a standard curve that is used to quantitate the percent inhibition after antisense oligonucleotide treatment of test samples.

Prior to quantitative PCR analysis, primer-probe sets specific to the target gene being measured are evaluated for their ability to be "multiplexed" with a GAPDH amplification reaction. In multiplexing, both the target gene and the internal standard gene GAPDH are amplified concurrently in a single sample. In this analysis, mRNA isolated from untreated cells is serially diluted. Each dilution is amplified in the presence of primer-probe sets specific for GAPDH only, target gene only ("single-

plexing"), or both (multiplexing). Following PCR amplification, standard curves of GAPDH and target mRNA signal as a function of dilution are generated from both the single-plexed and multiplexed samples. If both the slope and correlation coefficient of the GAPDH and target signals generated from the multiplexed samples fall within 10% of their corresponding values generated from the single-plexed samples, the primer-probe set specific for that target is deemed multiplexable. Other methods of PCR are also known in the art.

PCR reagents were obtained from Invitrogen Corporation, (Carlsbad, CA). RT-PCR reactions were carried out by adding 20  $\mu$ L PCR cocktail (2.5x PCR buffer minus MgCl<sub>2</sub>, 6.6 mM MgCl<sub>2</sub>, 375  $\mu$ M each of dATP, dCTP, dGTP and dTTP, 375 nM each of forward primer and reverse primer, 125 nM of probe, 4 Units RNase inhibitor, 1.25 Units PLATINUM® Taq, 5 Units MuLV reverse transcriptase, and 2.5x ROX dye) to 96-well plates containing 30  $\mu$ L total RNA solution (20-200 ng). The RT reaction was carried out by incubation for 30 minutes at 48°C. Following a 10 minute incubation at 95°C to activate the PLATINUM® Taq, 40 cycles of a two-step PCR protocol were carried out: 95°C for 15 seconds (denaturation) followed by 60°C for 1.5 minutes (annealing/extension).

Gene target quantities obtained by real time RT-PCR are normalized using either the expression level of GAPDH, a gene whose expression is constant, or by quantifying total RNA using RiboGreen™ (Molecular Probes, Inc. Eugene, OR). GAPDH expression is quantified by real time RT-PCR, by being run simultaneously with the target, multiplexing, or separately. Total RNA is quantified using RiboGreen™ RNA quantification reagent (Molecular Probes, Inc. Eugene, OR). Methods of RNA quantification by RiboGreen™ are taught in Jones, L.J., et al, (Analytical Biochemistry, 1998, 265, 368-374).

In this assay, 170  $\mu$ L of RiboGreen™ working reagent (RiboGreen™ reagent diluted 1:350 in 10mM Tris-HCl, 1 mM EDTA, pH 7.5) is pipetted into a 96-well plate containing 30  $\mu$ L purified, cellular RNA. The plate is read in a CytoFluor 4000 (PE Applied Biosystems) with excitation at 485nm and emission at 530nm.

Probes and are designed to hybridize to a human a target sequence, using published sequence information.

#### Example 24

**Northern blot analysis of a target mRNA levels**

Eighteen hours after antisense treatment, cell monolayers were washed twice with cold PBS and lysed in 1 mL RNAZOL™ (TEL-TEST "B" Inc., Friendswood, TX). Total RNA was prepared following manufacturer's recommended protocols. Twenty  
5 micrograms of total RNA was fractionated by electrophoresis through 1.2% agarose gels containing 1.1% formaldehyde using a MOPS buffer system (AMRESCO, Inc. Solon, OH). RNA was transferred from the gel to HYBOND™-N+ nylon membranes (Amersham Pharmacia Biotech, Piscataway, NJ) by overnight capillary transfer using a Northern/Southern Transfer buffer system (TEL-TEST "B" Inc., Friendswood, TX).  
10 RNA transfer was confirmed by UV visualization. Membranes were fixed by UV cross-linking using a STRATALINKER™ UV Crosslinker 2400 (Stratagene, Inc, La Jolla, CA) and then probed using QUICKHYB™ hybridization solution (Stratagene, La Jolla, CA) using manufacturer's recommendations for stringent conditions.

To detect human a target, a human a target specific primer probe set is prepared  
15 by PCR To normalize for variations in loading and transfer efficiency membranes are stripped and probed for human glyceraldehyde-3-phosphate dehydrogenase (GAPDH) RNA (Clontech, Palo Alto, CA).

Hybridized membranes were visualized and quantitated using a  
PHOSPHORIMAGER™ and IMAGEQUANT™ Software V3.3 (Molecular Dynamics,  
20 Sunnyvale, CA). Data was normalized to GAPDH levels in untreated controls.

**Example 25****Inhibition of human a target expression by oligomeric compounds**

In accordance with the present invention, a series of oligomeric compounds are  
25 designed to target different regions of the human target RNA. The oligomeric compounds are analyzed for their effect on human target mRNA levels by quantitative real-time PCR as described in other examples herein. Data are averages from three experiments. The target regions to which these preferred sequences are complementary are herein referred to as "preferred target segments" and are therefore preferred for  
30 targeting by oligomeric compounds of the present invention. The sequences represent the reverse complement of the preferred oligomeric compounds.

As these "preferred target segments" have been found by experimentation to be open to, and accessible for, hybridization with the oligomeric compounds of the present

invention, one of skill in the art will recognize or be able to ascertain, using no more than routine experimentation, further embodiments of the invention that encompass other oligomeric compounds that specifically hybridize to these preferred target segments and consequently inhibit the expression of a target.

5           According to the present invention, oligomeric compounds include antisense oligomeric compounds, antisense oligonucleotides, ribozymes, external guide sequence (EGS) oligonucleotides, alternate splicers, primers, probes, and other short oligomeric compounds which hybridize to at least a portion of the target nucleic acid.

## 10   **Example 26**

### **Western blot analysis of target protein levels**

          Western blot analysis (immunoblot analysis) is carried out using standard methods. Cells are harvested 16-20 h after oligonucleotide treatment, washed once with PBS, suspended in Laemmli buffer (100 ul/well), boiled for 5 minutes and loaded on a  
15   16% SDS-PAGE gel. Gels are run for 1.5 hours at 150 V, and transferred to membrane for western blotting. Appropriate primary antibody directed to a target is used, with a radiolabeled or fluorescently labeled secondary antibody directed against the primary antibody species. Bands are visualized using a PHOSPHORIMAGER™ (Molecular Dynamics, Sunnyvale CA).

20

## **Example 27**

### **Representative Cell lines**

#### **MCF-7 cells**

          The human breast carcinoma cell line MCF-7 is obtained from the American  
25   Type Culture Collection (Manassas, VA). These cells contain a wild-type p53 gene. MCF-7 cells are routinely cultured in DMEM low glucose (Gibco/Life Technologies, Gaithersburg, MD) supplemented with 10% fetal calf serum (Gibco/Life Technologies, Gaithersburg, MD). Cells are routinely passaged by trypsinization and dilution when they reach 90% confluence. Cells are seeded into 96-well plates (Falcon-Primaria  
30   #3872) at a density of 7000 cells/well for treatment with the oligomeric compounds of the invention.

#### **HepB3 cells**

          The human hepatoma cell line HepB3 (Hep3B2.1-7) is obtained from the



American Type Culture Collection (ATCC-ATCC Catalog # HB-8064) (Manassas, VA). This cell line was initially derived from a hepatocellular carcinoma of an 8-yr-old black male. The cells are epithelial in morphology and are tumorigenic in nude mice. HepB3 cells are routinely cultured in Minimum Essential Medium (MEM) with Earle's Balanced Salt Solution, 2 mM L-glutamine, 1.5 g/L sodium bicarbonate, 0.1 mM nonessential amino acids, 1.0 mM sodium pyruvate (ATCC #20-2003, Manassas, VA) and with 10% heat-inactivated fetal bovine serum (Gibco/Life Technologies, Gaithersburg, MD). Cells are routinely passaged by trypsinization and dilution when they reach 90% confluence.

#### **T-24 cells**

10 The transitional cell bladder carcinoma cell line T-24 is obtained from the American Type Culture Collection (ATCC) (Manassas, VA). T-24 cells are routinely cultured in complete McCoy's 5A basal media (Gibco/Life Technologies, Gaithersburg, MD) supplemented with 10% fetal calf serum (Gibco/Life Technologies, Gaithersburg, MD), penicillin 100 units per mL, and streptomycin 100 µg/mL (Gibco/Life Technologies, Gaithersburg, MD). Cells are routinely passaged by trypsinization and dilution when they reach 90% confluence. Cells are seeded into 96-well plates (Falcon-Primaria #3872) at a density of 7000 cells/well for treatment with the compound of the invention.

#### **A549 cells**

20 The human lung carcinoma cell line A549 is obtained from the American Type Culture Collection (ATCC) (Manassas, VA). A549 cells are routinely cultured in DMEM basal media (Gibco/Life Technologies, Gaithersburg, MD) supplemented with 10% fetal calf serum (Gibco/Life Technologies, Gaithersburg, MD), penicillin 100 units per mL, and streptomycin 100 µg/mL (Gibco/Life Technologies, Gaithersburg, MD). Cells are routinely passaged by trypsinization and dilution when they reach 90% confluence. Cells are seeded into 96-well plates (Falcon-Primaria #3872) at a density of 7000 cells/well for treatment with the compound of the invention.

#### **Primary mouse hepatocytes**

Primary mouse hepatocytes are prepared from CD-1 mice purchased from Charles River Labs. Primary mouse hepatocytes are routinely cultured in Hepatocyte Attachment Media (Invitrogen Life Technologies, Carlsbad, CA) supplemented with 10% Fetal Bovine Serum (Invitrogen Life Technologies, Carlsbad, CA), 250 nM dexamethasone (Sigma-Aldrich Corporation, St. Louis, MO), 10 nM bovine insulin

(Sigma-Aldrich Corporation, St. Louis, MO). Cells are seeded into 96-well plates (Falcon-Primaria #353872, BD Biosciences, Bedford, MA) at a density of 4000-6000 cells/well for treatment with the oligomeric compounds of the invention.

## 5 **Example 28**

### **Liposome-mediated treatment with oligomeric compounds of the invention**

When cells reach the desired confluency, they can be treated with the oligomeric compounds of the invention by liposome-mediated transfection. For cells grown in 96-well plates, wells are washed once with 200  $\mu$ L OPTI-MEM™-1 reduced-serum medium (Gibco BRL) and then treated with 100  $\mu$ L of OPTI-MEM™-1 containing 2.5  $\mu$ g/mL LIPOFECTIN™ (Gibco BRL) and the oligomeric compounds of the invention at the  
10 desired final concentration. After 4 hours of treatment, the medium is replaced with fresh medium. Cells are harvested 16 hours after treatment with the oligomeric compounds of the invention for target mRNA expression analysis by real-time PCR.

15

## **Example 29**

### **Electroporation-mediated treatment with oligomeric compounds of the invention**

When the cells reach the desired confluency, they can be treated with the oligomeric compounds of the invention by electroporation. Cells are electroporated in  
20 the presence of the desired concentration of an oligomeric compound of the invention in 1 mm cuvettes at a density of  $1 \times 10^7$  cells/mL, a voltage of 75V and a pulse length of 6 ms. Following the delivery of the electrical pulse, cells are replated for 16 to 24 hours. Cells are then harvested for target mRNA expression analysis by real-time PCR.

## 25 **Example 30**

### **Apoptosis assay**

Caspase-3 activity is evaluated with an fluorometric HTS Caspase-3 assay (Oncogene Research Products, San Diego, CA) that detects cleavage after aspartate residues in the peptide sequence (DEVD). The DEVD substrate is labeled with a  
30 fluorescent molecule, which exhibits a blue to green shift in fluorescence upon cleavage. Active caspase-3 in treated cells is measured by this assay according to the manufacturer's instructions. Following treatment with the oligomeric compounds of the invention, 50  $\mu$ L of assay buffer is added to each well, followed by addition 20  $\mu$ L of the

caspase-3 fluorescent substrate conjugate. Data are obtained in triplicate. Fluorescence in wells is immediately detected (excitation/emission 400/505 nm) using a fluorescent plate reader (SpectraMAX GeminiXS, Molecular Devices, Sunnyvale, CA). The plate is covered and incubated at 37°C for an additional three hours, after which the fluorescence is again measured (excitation/emission 400/505 nm). The value at time zero is subtracted from the measurement obtained at 3 hours. The measurement obtained from the untreated control cells is designated as 100% activity.

### **Example 31**

#### **10 Cell proliferation and viability assay**

Cell viability and proliferation are measured using the CyQuant Cell Proliferation Assay Kit (Molecular Probes, Eugene, OR) utilizing the CyQuant GR green fluorescent dye which exhibits strong fluorescence enhancement when bound to cellular nucleic acids. The assay is performed according to the manufacturer's instructions. After the treatment with one or more oligomeric compounds of the invention, the microplate is gently inverted to remove the medium from the wells, which are each washed once with 200 µL of phosphate-buffered saline. Plates are frozen at -70°C and then thawed. A volume of 200 µL of the CyQUANT GR dye/cell-lysis buffer is added to each well. The microplate is incubated for 5 minutes at room temperature, protected from light. Data are obtained in triplicate. Fluorescence in wells is immediately detected (excitation/emission 480/520 nm) using a fluorescent plate reader (SpectraMAX GeminiXS, Molecular Devices, Sunnyvale, CA). The measurement obtained from the untreated control cells is designated as 100% activity.

### **25 Example 32**

#### **Leptin-deficient mice: a model of obesity and diabetes (ob/ob mice)**

Leptin is a hormone produced by fat that regulates appetite. Deficiencies in this hormone in both humans and non-human animals leads to obesity. ob/ob mice have a mutation in the leptin gene which results in obesity and hyperglycemia. As such, these mice are a useful model for the investigation of obesity and diabetes and treatments designed to treat these conditions. ob/ob mice have higher circulating levels of insulin and are less hyperglycemic than db/db mice, which harbor a mutation in the leptin

receptor. In accordance with the present invention, the oligomeric compounds of the invention are tested in the ob/ob model of obesity and diabetes.

Seven-week old male C57Bl/6J-Lepr ob/ob mice (Jackson Laboratory, Bar Harbor, ME) are fed a diet with a fat content of 10-15% and are subcutaneously injected  
5 with the oligomeric compounds of the invention or a control compound at a dose of 25 mg/kg two times per week for 4 weeks. Saline-injected animals, leptin wildtype littermates (i.e. lean littermates) and ob/ob mice fed a standard rodent diet serve as controls. After the treatment period, mice are sacrificed and target levels are evaluated in  
10 liver, brown adipose tissue (BAT) and white adipose tissue (WAT). RNA isolation and target mRNA expression level quantitation are performed as described by other examples herein.

To assess the physiological effects resulting from inhibition of target mRNA, the ob/ob mice are further evaluated at the end of the treatment period for serum lipids, serum free fatty acids, serum cholesterol (CHOL), liver triglycerides, fat tissue  
15 triglycerides and liver enzyme levels. Hepatic steatosis, or clearing of lipids from the liver, is assessed by measuring the liver triglyceride content. Hepatic steatosis is assessed by routine histological analysis of frozen liver tissue sections stained with oil red O stain, which is commonly used to visualize lipid deposits, and counterstained with hematoxylin and eosin, to visualize nuclei and cytoplasm, respectively.

20 The effects of target inhibition on glucose and insulin metabolism are evaluated in the ob/ob mice treated with the oligomeric compounds of the invention. Plasma glucose is measured at the start of the treatment and after 2 weeks and 4 weeks of treatment. Plasma insulin is similarly measured at the beginning of the treatment, and following at 2 weeks and at 4 weeks of treatment. Glucose and insulin tolerance tests are  
25 also administered in fed and fasted mice. Mice receive intraperitoneal injections of either glucose or insulin, and the blood glucose and insulin levels are measured before the insulin or glucose challenge and at 15, 20 or 30 minute intervals for up to 3 hours.

To assess the metabolic rate of ob/ob mice treated with the oligomeric  
30 compounds of the invention, the respiratory quotient and oxygen consumption of the mice are also measured.

The ob/ob mice that received treatment are further evaluated at the end of the treatment period for the effects of target inhibition on the expression genes that participate in lipid metabolism, cholesterol biosynthesis, fatty acid oxidation, fatty acid storage, gluconeogenesis and glucose metabolism. These genes include, but are not

limited to, HMG-CoA reductase, acetyl-CoA carboxylase 1 and acetyl-CoA carboxylase 2, carnitine palmitoyltransferase I and glycogen phosphorylase, glucose-6-phosphatase and phosphoenolpyruvate carboxykinase 1, lipoprotein lipase and hormone sensitive lipase. mRNA levels in liver and white and brown adipose tissue are quantitated by real-time PCR as described in other examples herein, employing primer-probe sets that are generated using published sequences of each gene of interest.

### **Example 33**

#### **Leptin receptor-deficient mice: a model of obesity and diabetes (db/db mice)**

Leptin is a hormone produced by fat that regulates appetite. Deficiencies in this hormone in both humans and non-human animals leads to obesity. db/db mice have a mutation in the leptin receptor gene which results in obesity and hyperglycemia. As such, these mice are a useful model for the investigation of obesity and diabetes and treatments designed to treat these conditions. db/db mice, which have lower circulating levels of insulin and are more hyperglycemic than ob/ob mice which harbor a mutation in the leptin gene, are often used as a rodent model of type 2 diabetes. In accordance with the present invention, oligomeric compounds of the present invention are tested in the db/db model of obesity and diabetes.

Seven-week old male C57Bl/6J-Lepr db/db mice (Jackson Laboratory, Bar Harbor, ME) are fed a diet with a fat content of 15-20% and are subcutaneously injected with one or more of the oligomeric compounds of the invention or a control compound at a dose of 25 mg/kg two times per week for 4 weeks. Saline-injected animals, leptin receptor wildtype littermates (i.e. lean littermates) and db/db mice fed a standard rodent diet serve as controls. After the treatment period, mice are sacrificed and target levels are evaluated in liver, brown adipose tissue (BAT) and white adipose tissue (WAT). RNA isolation and target mRNA expression level quantitation are performed as described by other examples herein.

After the treatment period, mice are sacrificed and target levels are evaluated in liver, brown adipose tissue (BAT) and white adipose tissue (WAT). RNA isolation and target mRNA expression level quantitation are performed as described by other examples herein.

To assess the physiological effects resulting from inhibition of target mRNA, the db/db mice that receive treatment are further evaluated at the end of the treatment period for serum lipids, serum free fatty acids, serum cholesterol (CHOL), liver triglycerides,

fat tissue triglycerides and liver enzyme levels. Hepatic steatosis, or clearing of lipids from the liver, is assessed by measuring the liver triglyceride content. Hepatic steatosis is also assessed by routine histological analysis of frozen liver tissue sections stained with oil red O stain, which is commonly used to visualize lipid deposits, and  
5 counterstained with hematoxylin and eosin, to visualize nuclei and cytoplasm, respectively.

The effects of target inhibition on glucose and insulin metabolism are also evaluated in the db/db mice treated with the oligomeric compounds of the invention. Plasma glucose is measured at the start of the treatment and after 2 weeks and 4 weeks of  
10 treatment. Plasma insulin is similarly measured at the beginning of the treatment, and following 2 weeks and 4 weeks of treatment. Glucose and insulin tolerance tests are also administered in fed and fasted mice. Mice receive intraperitoneal injections of either glucose or insulin, and the blood glucose levels are measured before the insulin or glucose challenge and 15, 30, 60, 90 and 120 minutes following the injection.

15 To assess the metabolic rate of db/db mice treated with the oligomeric compounds of the invention, the respiratory quotient and oxygen consumption of the mice is also measured.

The db/db mice that receive treatment are further evaluated at the end of the treatment period for the effects of target inhibition on the expression genes that  
20 participate in lipid metabolism, cholesterol biosynthesis, fatty acid oxidation, fatty acid storage, gluconeogenesis and glucose metabolism. These genes include, but are not limited to, HMG-CoA reductase, acetyl-CoA carboxylase 1 and acetyl-CoA carboxylase 2, carnitine palmitoyltransferase I and glycogen phosphorylase, glucose-6-phosphatase and phosphoenolpyruvate carboxykinase 1, lipoprotein lipase and hormone sensitive  
25 lipase. mRNA levels in liver and white and brown adipose tissue are quantitated by real-time PCR as described in other examples herein, employing primer-probe sets that are generated using published sequences of each gene of interest.

#### **Example 34**

##### **30 Lean mice on a standard rodent diet**

C57Bl/6 mice are maintained on a standard rodent diet and are used as control (lean) animals. In a further embodiment of the present invention, the oligomeric compounds of the invention are tested in normal, lean animals.

Seven-week old male C57Bl/6 mice are fed a diet with a fat content of 4% and are subcutaneously injected with one or more of the oligomeric compounds of the invention or control compounds at a dose of 25 mg/kg two times per week for 4 weeks. Saline-injected animals serve as a control. After the treatment period, mice are sacrificed and target levels are evaluated in liver, brown adipose tissue (BAT) and white adipose tissue (WAT). RNA isolation and target mRNA expression level quantitation are performed as described by other examples herein.

After the treatment period, mice are sacrificed and target levels are evaluated in liver, brown adipose tissue (BAT) and white adipose tissue (WAT). RNA isolation and target mRNA expression level quantitation are performed as described by other examples herein.

To assess the physiological effects resulting from inhibition of target mRNA, the lean mice that receive treatment are further evaluated at the end of the treatment period for serum lipids, serum free fatty acids, serum cholesterol (CHOL), liver triglycerides, fat tissue triglycerides and liver enzyme levels. Hepatic steatosis, or clearing of lipids from the liver, is assessed by measuring the liver triglyceride content. Hepatic steatosis is also assessed by routine histological analysis of frozen liver tissue sections stained with oil red O stain, which is commonly used to visualize lipid deposits, and counterstained with hematoxylin and eosin, to visualize nuclei and cytoplasm, respectively.

The effects of target inhibition on glucose and insulin metabolism are also evaluated in the lean mice treated with the oligomeric compounds of the invention. Plasma glucose is measured at the start of the treatment and after 2 weeks and 4 weeks of treatment. Plasma insulin is similarly measured at the beginning of the treatment, and following 2 weeks and 4 weeks of treatment. Glucose and insulin tolerance tests are also administered in fed and fasted mice. Mice receive intraperitoneal injections of either glucose or insulin, and the blood glucose levels are measured before the insulin or glucose challenge and 15, 30, 60, 90 and 120 minutes following the injection.

To assess the metabolic rate of lean mice treated with the oligomeric compounds of the invention, the respiratory quotient and oxygen consumption of the mice is also measured.

The lean mice that received treatment are further evaluated at the end of the treatment period for the effects of target inhibition on the expression genes that participate in lipid metabolism, cholesterol biosynthesis, fatty acid oxidation, fatty acid

storage, gluconeogenesis and glucose metabolism. These genes include, but are not limited to, HMG-CoA reductase, acetyl-CoA carboxylase 1 and acetyl-CoA carboxylase 2, carnitine palmitoyltransferase I and glycogen phosphorylase, glucose-6-phosphatase and phosphoenolpyruvate carboxykinase 1, lipoprotein lipase and hormone sensitive lipase. mRNA levels in liver and white and brown adipose tissue are quantitated by real-time PCR as described in other examples herein, employing primer-probe sets that are generated using published sequences of each gene of interest.

### Example 35

#### 10 Activity Profiles of 20-mer blunt constructs with Full 2'OMe & 2'MOE Sense Strands.

Blunt constructs designed against human PTEN 29592, (See Table 4 below for Isis Construct Numbers) were tested for their ability to mediate PTEN mRNA reduction in HeLa at doses between 0.6nM and 75nM. Construct modifications and linkage are indicated in Table 4 below; modifications indicate each construct is fully modified. Data are normalized to untreated control and are presented in Table 4 as approximate % of control for each dose, wherein a percentage less than 100 indicates reduction of PTEN mRNA levels.

20

Table 4

Construct design (antisense:sense)	Isis Numbers (antisense + sense)	Sample	Dose of construct			
			0.6 nM	3 nM	15 nM	75 nM
PO:PO	335449 + 308746	A	94	69	32	21
PO:PS	335449 + 344178	B	103	60	25	23
PO:PO_2'Ome	335449 + 330696	C	129	92	54	44
PO:PS_2'Ome	335449 + 341315	D	109	67	27	31
PO:PO_MOE	335449 + 356426	E	143	123	72	76
PO:PS_MOE	335449 + 356427	F	119	79	40	44
Mismatch	308745 + 354622		128	134	95	83
PS:PO	303912 + 308746	G	120	80	28	25
PS:PS	303912 + 344178	H	110	66	23	25
PS:PO_2'Ome	303912 + 330696	I	119	78	24	29
PS:PS_2'Ome	303912 + 341315	J	78	62	31	27



PS:PO_MOE	303912 + 356426	K	83	60	45	24
PS:PS_MOE	303912 + 356427	L	97	106	99	106

As shown in Table 4, all constructs targeted to PTEN except ISIS 303912 +356427, inhibited mRNA levels by at least 20% at the 75 nM dose. In addition, several constructs showed an apparent dose-dependent effect on PTEN mRNA levels.

5	<u>SEQ ID No:</u>	<u>ISIS No:</u>	<u>Sequence 5' to 3'</u>
	1	335449	P-UUUGUCUCUGGUCCUUACUU
	2	308746	AAGUAAGGACCAGAGACAAA
	2	330696	A <sub>m</sub> A <sub>m</sub> G <sub>m</sub> U <sub>m</sub> A <sub>m</sub> A <sub>m</sub> G <sub>m</sub> G <sub>m</sub> A <sub>m</sub> C <sub>m</sub> C <sub>m</sub> A <sub>m</sub> G <sub>m</sub> A <sub>m</sub> G <sub>m</sub> A <sub>m</sub> C <sub>m</sub> A <sub>m</sub> A <sub>m</sub> A <sub>m</sub>
10	1	303912	P-
			U*U*U*G*U*C*U*C*U*G*G*U*C*C*U*U*A*C*U*U
	23	308745	TTTATCGCTTCTCGTTGCTT
	2	341315	AAGTAAGGACCAGAGACAAA
	2	344178	AAGTAAGGACCAGAGACAAA
15	24	354622	AAGCAACGAGAAGCGATAAA
	2	356426	AAGTAAGGACCAGAGACAAA
	2	356427	AAGTAAGGACCAGAGACAAA.

Where \* is a phosphorothioate internucleoside linkage, P- is a 5'-phosphate group and m is a 2'-O-methyl group.

20 It is intended that each publication referred to in this application, including but not limited to books, references, patents and patent applications, be incorporated herein in their entirety.

**What is claimed is:**

1. A composition comprising a first oligomeric compound and a second oligomeric compound, wherein:
  - 5 at least a portion of said first oligomeric compound is capable of hybridizing with at least a portion of said second oligomeric compound,  
at least a portion of said first oligomeric compound is complementary to and capable of hybridizing to a selected target nucleic acid,  
one of said first and said second oligomeric compounds comprises a plurality of  
10 linked nucleosides linked by internucleoside linking groups, and  
the other one of said first and said second oligomeric compounds comprises a plurality of linked nucleosides linked by internucleoside linking groups and wherein essentially each of said nucleosides is other than 2'-OH and have 3'-endo conformational geometry;
  - 15 wherein said first and second oligomeric compounds optionally comprise at least one phosphate group, a 5' or 3'-overhang or a conjugate group.
2. The composition of claim 1 wherein said first oligomeric compound comprises a plurality of linked nucleosides linked by internucleoside linking groups and wherein  
20 essentially each of said nucleosides is other than 2'-OH and have 3'-endo conformational geometry.
3. The composition of claim 1 wherein said second oligomeric compound comprises a plurality of linked nucleosides linked by internucleoside linking groups and wherein  
25 essentially each of said nucleosides is other than 2'-OH and have 3'-endo conformational geometry.
4. The composition of claim 1 wherein each of said nucleosides of said first oligomeric compound comprise a  $\beta$ -D-ribofuranose sugar group.  
30
5. The composition of claim 1 wherein each of said nucleosides of said second oligomeric compound comprise a  $\beta$ -D-ribofuranose sugar group.

6. The composition of claim 1 wherein the 3'-terminus of said first oligomeric compound comprises a stabilizing or conjugate group.
7. The composition of claim 6 wherein said stabilizing group is a capping group or a dTdT dimer.
8. The composition of claim 6 wherein the 3'-terminus of said first oligomeric compound comprises a conjugate group.
9. The composition of claim 1 wherein said first oligomeric compound comprises a 5'-phosphate group.
10. The composition of claim 1 wherein the 5'-terminus of said first oligomeric compound comprises a stabilizing or conjugate group.
11. The composition of claim 10 wherein said stabilizing group is a capping group.
12. The composition of claim 10 wherein the 5'-terminus of said first oligomeric compound comprises a conjugate group.
13. The composition of claim 1 wherein said second oligomeric compound has a 5'-phosphate group.
14. The composition of claim 1 wherein each of said internucleoside linking groups of said first oligomeric compound is, independently, a phosphodiester or a phosphorothioate.
15. The composition of claim 14 wherein each of said internucleoside linking groups of said first oligomeric compound is a phosphodiester.
16. The composition of claim 14 wherein each of said internucleoside linking groups of said first oligomeric compound is a phosphorothioate.

17. The composition of claim 1 wherein each of said internucleoside linking groups of said second oligomeric compound is, independently, a phosphodiester or a phosphorothioate.
- 5 18. The composition of claim 17 wherein each of said internucleoside linking groups of said second oligomeric compound is a phosphodiester.
19. The composition of claim 17 wherein each of said internucleoside linking groups of said second oligomeric compound is a phosphorothioate.
- 10 20. The composition of claim 1 wherein the 3'-terminus of said second oligomeric compound comprises a stabilizing or conjugate group.
21. The composition of claim 20 wherein said stabilizing group is a capping group or  
15 a dTdT dimer.
22. The composition of claim 20 wherein the 3'-terminus of said second oligomeric compound comprises a conjugate group.
- 20 23. The composition of claim 1 wherein the 5'-terminus of said second oligomeric compound comprises a stabilizing or conjugate group.
24. The composition of claim 23 wherein said stabilizing group is a capping group.
- 25 25. The composition of claim 23 wherein the 5'-terminus of said second oligomeric compound comprises a conjugate group.
26. The composition of claim 2 wherein each of said nucleosides of said second oligomeric compound has 3'-endo conformational geometry.
- 30 27. The composition of claim 3 wherein each of said nucleosides of said first oligomeric compound has 3'-endo conformational geometry.

28. The composition of claim 1 wherein each of said nucleoside having 3'-endo conformational geometry comprises a 2'-substituent group.

29. The composition of claim 28 wherein each of said 2'-substituent groups is, independently, -F, -O-CH<sub>2</sub>CH<sub>2</sub>-O-CH<sub>3</sub>, -O-CH<sub>3</sub>, -O-CH<sub>2</sub>-CH=CH<sub>2</sub> or a group having one of formula I<sub>a</sub> or II<sub>a</sub>:

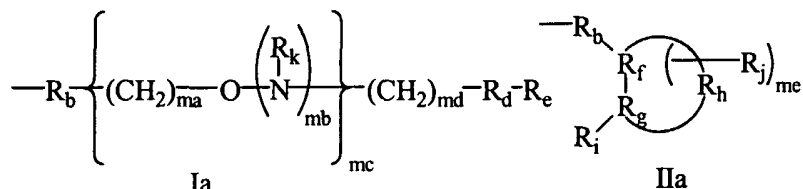

wherein:

- 10  $R_b$  is O, S or NH;  
 $R_d$  is a single bond, O, S or C(=O);  
 $R_e$  is C<sub>1</sub>-C<sub>10</sub> alkyl, N(R<sub>k</sub>)(R<sub>m</sub>), N(R<sub>k</sub>)(R<sub>n</sub>), N=C(R<sub>p</sub>)(R<sub>q</sub>), N=C(R<sub>p</sub>)(R<sub>r</sub>) or has formula III<sub>a</sub>;

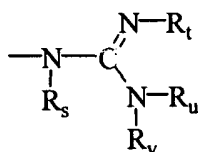

- 15  $R_p$  and  $R_q$  are each independently hydrogen or C<sub>1</sub>-C<sub>10</sub> alkyl;  
 $R_r$  is -R<sub>x</sub>-R<sub>y</sub>;  
each  $R_s$ ,  $R_t$ ,  $R_u$  and  $R_v$  is, independently, hydrogen, C(O)R<sub>w</sub>, substituted or unsubstituted C<sub>1</sub>-C<sub>10</sub> alkyl, substituted or unsubstituted C<sub>2</sub>-C<sub>10</sub> alkenyl, substituted or unsubstituted C<sub>2</sub>-C<sub>10</sub> alkynyl, alkylsulfonyl, arylsulfonyl, a chemical functional group or a conjugate group, wherein the substituent groups are selected from hydroxyl, amino, alkoxy, carboxy, benzyl, phenyl, nitro, thiol, thioalkoxy, halogen, alkyl, aryl, alkenyl and alkynyl;
- or optionally,  $R_u$  and  $R_v$ , together form a phthalimido moiety with the nitrogen atom to which they are attached;
- 25 each  $R_w$  is, independently, substituted or unsubstituted C<sub>1</sub>-C<sub>10</sub> alkyl, trifluoromethyl, cyanoethoxy, methoxy, ethoxy, t-butoxy, allyloxy, 9-

fluorenylmethoxy, 2-(trimethylsilyl)-ethoxy, 2,2,2-trichloroethoxy, benzyloxy, butyryl, iso-butyryl, phenyl or aryl;

$R_k$  is hydrogen, a nitrogen protecting group or  $-R_x-R_y$ ;

$R_p$  is hydrogen, a nitrogen protecting group or  $-R_x-R_y$ ;

5  $R_x$  is a bond or a linking moiety;

$R_y$  is a chemical functional group, a conjugate group or a solid support medium;

each  $R_m$  and  $R_n$  is, independently, H, a nitrogen protecting group, substituted or unsubstituted  $C_1-C_{10}$  alkyl, substituted or unsubstituted  $C_2-C_{10}$  alkenyl, substituted or unsubstituted  $C_2-C_{10}$  alkynyl, wherein the substituent groups are selected from hydroxyl, amino, alkoxy, carboxy, benzyl, phenyl, nitro, thiol, thioalkoxy, halogen, alkyl, aryl, alkenyl, alkynyl;  $NH_3^+$ ,  $N(R_u)(R_v)$ , guanidino and acyl where said acyl is an acid amide or an ester;

or  $R_m$  and  $R_n$ , together, are a nitrogen protecting group, are joined in a ring structure that optionally includes an additional heteroatom selected from N and O or are a chemical functional group;

$R_i$  is  $OR_z$ ,  $SR_z$ , or  $N(R_z)_2$ ;

each  $R_z$  is, independently, H,  $C_1-C_8$  alkyl,  $C_1-C_8$  haloalkyl,  $C(=NH)N(H)R_u$ ,  $C(=O)N(H)R_u$  or  $OC(=O)N(H)R_u$ ;

$R_f$ ,  $R_g$  and  $R_h$  comprise a ring system having from about 4 to about 7 carbon atoms or having from about 3 to about 6 carbon atoms and 1 or 2 heteroatoms wherein said heteroatoms are selected from oxygen, nitrogen and sulfur and wherein said ring system is aliphatic, unsaturated aliphatic, aromatic, or saturated or unsaturated heterocyclic;

$R_j$  is alkyl or haloalkyl having 1 to about 10 carbon atoms, alkenyl having 2 to about 10 carbon atoms, alkynyl having 2 to about 10 carbon atoms, aryl having 6 to about 14 carbon atoms,  $N(R_k)(R_m)$   $OR_k$ , halo,  $SR_k$  or CN;

$m_a$  is 1 to about 10;

each  $m_b$  is, independently, 0 or 1;

$m_c$  is 0 or an integer from 1 to 10;

30  $m_d$  is an integer from 1 to 10;

$m_e$  is from 0, 1 or 2; and

provided that when  $m_c$  is 0,  $m_d$  is greater than 1.

30. The composition of claim 28 wherein each of said 2'-substituent groups is, independently, -F, -O-CH<sub>2</sub>CH<sub>2</sub>-O-CH<sub>3</sub>, -O-CH<sub>3</sub>, -O-CH<sub>2</sub>-CH=CH<sub>2</sub> or -O-CH<sub>2</sub>-CH-CH<sub>2</sub>-NH(R<sub>j</sub>) where R<sub>j</sub> is H or C<sub>1</sub>-C<sub>10</sub> alkyl.
- 5 31. The composition of claim 28 wherein each of said 2'-substituent groups is, independently, -F, -O-CH<sub>2</sub>CH<sub>2</sub>-O-CH<sub>3</sub> or -O-CH<sub>3</sub>.
32. The composition of claim 31 wherein each of said 2'-substituent groups is -O-CH<sub>3</sub>.
- 10 33. The composition of claim 32 wherein each of said internucleoside linking groups of said first oligomeric compound is a phosphodiester.
34. The composition of claim 33 wherein each of said internucleoside linking groups  
15 of said second oligomeric compound is a phosphodiester.
35. The composition of claim 33 wherein each of said internucleoside linking groups of said second oligomeric compound is a phosphorothioate.
- 20 36. The composition of claim 28 wherein each of said internucleoside linking groups of said first oligomeric compound is a phosphorothioate.
37. The composition of claim 36 wherein each of said internucleoside linking groups of said second oligomeric compound is a phosphodiester.
- 25 38. The composition of claim 36 wherein each of said internucleoside linking groups of said second oligomeric compound is a phosphorothioate.
39. The composition of claim 1 wherein said first and said second oligomeric  
30 compounds are a complementary pair of siRNA oligonucleotides.
40. The composition of claim 39 wherein said first and said second oligomeric compounds have 3'-dTdT overhangs.

41. The composition of claim 39 wherein said first and said second oligomeric compounds have blunt ends.
42. The oligomeric compound of claim 1 further comprising at least one terminal cap moiety.
43. The oligomeric compound of claim 42 wherein said terminal cap moiety is attached to one or both of the 3'-terminal and 5'-terminal ends of said oligomeric compound.
44. The oligomeric compound of claim 43 wherein said terminal cap moiety is an inverted deoxy abasic moiety.
45. The composition of claim 1 wherein said first and said second oligomeric compounds are an antisense/sense pair of oligonucleotides.
46. The composition of claim 1 wherein each of said first and second oligomeric compounds has from about 8 to about 80 nucleobases.
47. The composition of claim 1 wherein each of said first and second oligomeric compounds has from about 10 to about 50 nucleobases.
48. The composition of claim 1 wherein each of said first and second oligomeric compounds has from about 12 to about 30 nucleobases.
49. The composition of claim 1 wherein each of said first and second oligomeric compounds has from about 12 to about 24 nucleobases.
50. The composition of claim 1 wherein each of said first and second oligomeric compounds has from about 19 to about 23 nucleobases.
51. The composition of claim 1 wherein said first oligomeric compound is an antisense oligonucleotide.



52. The composition of claim 51 wherein said second oligomeric compound is a sense oligonucleotide.

53. A method of inhibiting gene expression comprising contacting one or more cells,  
5 a tissue or an animal with a composition of claim 1.