

(19) World Intellectual Property Organization
International Bureau



(43) International Publication Date
29 July 2010 (29.07.2010)

PCT

(10) International Publication Number
WO 2010/085659 A1

(51) International Patent Classification:
A61F 2/24 (2006.01)

(21) International Application Number:
PCT/US2010/021822

(22) International Filing Date:
22 January 2010 (22.01.2010)

(25) Filing Language: English

(26) Publication Language: English

(30) Priority Data:
61/146,569 22 January 2009 (22.01.2009) US

(71) Applicant (for all designated States except US): **ST. JUDE MEDICAL** [US/US]; Cardiovascular Division, 177 East County Road B, St. Paul, Minnesota 55117-9913 (US).

(72) Inventors; and

(75) Inventors/Applicants (for US only): **CARTLEDGE, Richard, G.** [US/US]; 4217 Mangrum Court, Hollywood, Florida 33301 (US). **LEE, Leonard, Y.** [US/US]; 300 East 64th Street, #21B, New York, New York 10021 (US).

(74) Agent: **CROWSON, Celine, Jimenez**; Hogan Hartson LLP, 555 Thirteenth Street, N.W., Washington, District of Columbia 20004 (US).

(81) Designated States (unless otherwise indicated, for every kind of national protection available): AE, AG, AL, AM, AO, AT, AU, AZ, BA, BB, BG, BH, BR, BW, BY, BZ, CA, CH, CL, CN, CO, CR, CU, CZ, DE, DK, DM, DO, DZ, EC, EE, EG, ES, FI, GB, GD, GE, GH, GM, GT, HN, HR, HU, ID, IL, IN, IS, JP, KE, KG, KM, KN, KP, KR, KZ, LA, LC, LK, LR, LS, LT, LU, LY, MA, MD, ME, MG, MK, MN, MW, MX, MY, MZ, NA, NG, NI, NO, NZ, OM, PE, PG, PH, PL, PT, RO, RS, RU, SC, SD, SE, SG, SK, SL, SM, ST, SV, SY, TH, TJ, TM, TN, TR, TT, TZ, UA, UG, US, UZ, VC, VN, ZA, ZM, ZW.

(84) Designated States (unless otherwise indicated, for every kind of regional protection available): ARIPO (BW, GH, GM, KE, LS, MW, MZ, NA, SD, SL, SZ, TZ, UG, ZM, ZW), Eurasian (AM, AZ, BY, KG, KZ, MD, RU, TJ, TM), European (AT, BE, BG, CH, CY, CZ, DE, DK, EE, ES, FI, FR, GB, GR, HR, HU, IE, IS, IT, LT, LU, LV, MC, MK, MT, NL, NO, PL, PT, RO, SE, SI, SK, SM, TR), OAPI (BF, BJ, CF, CG, CI, CM, GA, GN, GQ, GW, ML, MR, NE, SN, TD, TG).

Published:

— with international search report (Art. 21(3))

(54) Title: MAGNETIC DOCKING SYSTEM AND METHOD FOR THE LONG TERM ADJUSTMENT OF AN IMPLANTABLE DEVICE

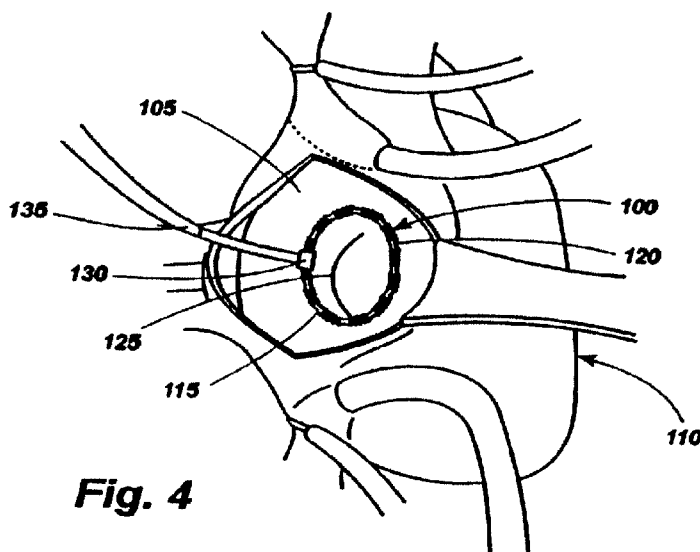

Fig. 4

(57) Abstract: An implantable device for controlling the circumference of internal anatomic passages corrects physiologic dysfunctions resulting from a structural lumen which is either too large or too small. Implants are disclosed which employ various means for adjusting and maintaining the size of an orifice to which they are attached. Systems permit the implants to be implanted using minimally invasive procedures and permit final adjustments to the circumference of the implants after the resumption of normal flow of anatomic fluids in situ. The invention may include an adjustment tool for making the final adjustments to the circumference that locks onto the adjustment means of the device with magnets. Methods are disclosed for using the implants to treat heart valve abnormalities, gastroesophageal abnormalities, anal incontinence, and the like.



WO 2010/085659 A1

MAGNETIC DOCKING SYSTEM AND METHOD FOR THE
LONG TERM ADJUSTMENT OF AN IMPLANTABLE DEVICE

CROSS REFERENCE TO RELATED APPLICATIONS

[0001] The application claims priority to United States Provisional Application No. 61/146,569, filed January 22, 2009, which application is expressly incorporated herein by reference in its entirety.

TECHNICAL FIELD

[0002] The present invention relates generally to implantable devices and procedures and relates more specifically to implantable devices and procedures for controlling the internal circumference of an anatomic orifice or lumen.

BACKGROUND OF THE INVENTION

[0003] Many anatomic structures in the mammalian body are hollow passages in which walls of tissue define a central lumen, which serves as a conduit for blood, other physiologic fluids, nutrient matter, or waste matter passing within the structure. In many physiologic settings, dysfunction may result from a structural lumen which is either too large or too small. In most such cases, dysfunction can be relieved by interventional changes in the luminal size.

[0004] Thus in surgery, there is often a need to reduce the internal circumference of an orifice or other open anatomic structure to narrow the size of the orifice or opening to achieve a desired physiologic effect. Often, such surgical procedures require interruption in the normal physiologic flow of blood, other physiologic fluids, or other structural contents through the orifice or structure. The exact amount of the narrowing required for the desired effect often cannot be fully appreciated until physiologic flow through the orifice or structure is resumed. It would be advantageous, therefore, to have an adjustable means of achieving this narrowing effect, such that the degree of narrowing could be changed after its implantation, but after the resumption of normal flow in situ.

[0005] One example of a dysfunction within an anatomic lumen is in the area of cardiac surgery, and specifically valvular repair. Approximately one million open heart

surgical procedures are now performed annually in the United States, and twenty percent of these operations are related to cardiac valves.

[0006] The field of cardiac surgery was previously transformed by the introduction of the pump oxygenator, which allowed open heart surgery to be performed. Valvular heart surgery was made possible by the further introduction of the mechanical ball-valve prosthesis, and many modifications and different forms of prosthetic heart valves have since been developed. However, the ideal prosthetic valve has yet to be designed, which attests to the elegant form and function of the native heart valve. As a result of the difficulties in engineering a perfect prosthetic heart valve, there has been growing interest in repairing a patient's native valve. These efforts have documented equal long-term durability to the use of mechanical prostheses, with added benefits of better ventricular performance due to preservation of the subvalvular mechanisms and obviation of the need for chronic anticoagulation. Mitral valve repair has become one of the most rapidly growing areas in adult cardiac surgery today.

[0007] Mitral valve disease can be subdivided into intrinsic valve disturbances and pathology extrinsic to the mitral valve ultimately affecting valvular function. Although these subdivisions exist, many of the repair techniques and overall operative approaches are similar in the various pathologies that exist.

[0008] Historically, most valvular pathology was secondary to rheumatic heart disease, a result of a streptococcal infection, most commonly affecting the mitral valve, followed by the aortic valve, and least often the pulmonic valve. The results of the infectious process are mitral stenosis and aortic stenosis, followed by mitral insufficiency and aortic insufficiency. With the advent of better antibiotic therapies, the incidence of rheumatic heart disease is on the decline, and accounts for a smaller percentage of valvular heart conditions in the developed world of the present day. Commissurotomy of rheumatic mitral stenosis was an early example of commonly practiced mitral valve repair outside of the realm of congenital heart defects. However, the repairs of rheumatic insufficient valves have not met with good results due to the underlying valve pathology and the progression of disease.

[0009] Most mitral valve disease other than rheumatic results in valvular insufficiency that is generally amenable to repair. Chordae rupture is a common cause of mitral insufficiency, resulting in a focal area of regurgitation. Classically, one of the first successful and accepted surgical repairs was for ruptured chordae of the posterior mitral

leaflet. The technical feasibility of this repair, its reproducible good results, and its long-term durability led the pioneer surgeons in the field of mitral valve repair to attempt repairs of other valve pathologies.

[0010] Mitral valve prolapse is a fairly common condition that leads over time to valvular insufficiency. In this disease, the plane of coaptation of the anterior and posterior leaflets is "atrialized" relative to a normal valve. This problem may readily be repaired by restoring the plane of coaptation into the ventricle.

[0011] The papillary muscles within the left ventricle support the mitral valve and aid in its function. Papillary muscle dysfunction, whether due to infarction or ischemia from coronary artery disease, often leads to mitral insufficiency (commonly referred to as ischemic mitral insufficiency). Within the scope of mitral valve disease, this is the most rapidly growing area for valve repair. Historically, only patients with severe mitral insufficiency were repaired or replaced, but there is increasing support in the surgical literature to support valve repair in patients with moderate insufficiency that is attributable to ischemic mitral insufficiency. Early aggressive valve repair in this patient population has been shown to increase survival and improve long-term ventricular function.

[0012] In addition, in patients with dilated cardiomyopathy the etiology of mitral insufficiency is the lack of coaptation of the valve leaflets from a dilated ventricle. The resultant regurgitation is due to the lack of coaptation of the leaflets. There is a growing trend to repair these valves, thereby repairing the insufficiency and restoring ventricular geometry, thus improving overall ventricular function.

[0013] The two essential features of mitral valve repair are to fix primary valvular pathology (if present) and to support the annulus or reduce the annular dimension using a prosthesis that is commonly in the form of a ring or band. The problem encountered in mitral valve repair is the surgeon's inability to fully assess the effectiveness of the repair until the heart has been fully closed, and the patient is weaned off cardiopulmonary bypass. Once this has been achieved, valvular function can be assessed in the operating room using transesophageal echocardiography (TEE). If significant residual valvular insufficiency is then documented, the surgeon must re-arrest the heart, re-open the heart, and then re-repair or replace the valve. This increases overall operative, anesthesia, and bypass times, and therefore increases the overall operative risks.

[0014] If the prosthesis used to reduce the annulus is larger than the ideal size, mitral insufficiency may persist. If the prosthesis is too small, mitral stenosis may result.

The need exists, therefore, for an adjustable prosthesis that would allow a surgeon to adjust the annular dimension in situ in a beating heart under TEE guidance or other diagnostic modalities to achieve optimal valvular sufficiency and function.

[0015] Cardiac surgery is but one example of a setting in which adjustment of the annular dimension of an anatomic orifice in situ would be desirable. Another example is in the field of gastrointestinal surgery, where the Nissen fundoplication procedure has long been used to narrow the gastro-esophageal junction for relief of gastric reflux into the esophagus. In this setting, a surgeon is conventionally faced with the tension between creating sufficient narrowing to achieve reflux control, but avoiding excessive narrowing that may interfere with the passage of nutrient contents from the esophagus into the stomach. Again, it would be desirable to have a method and apparatus by which the extent to which the gastro-esophageal junction is narrowed could be adjusted in situ to achieve optimal balance between these two competing interests.

[0016] Aside from the problem of adjusting the internal circumference of body passages in situ, there is often a need in medicine and surgery to place a prosthetic implant at a desired recipient anatomic site. For example, existing methods proposed for percutaneous mitral repair include approaches through either the coronary sinus or percutaneous attempts to affix the anterior mitral leaflet to the posterior mitral leaflet. Significant clinical and logistical problems attend both of these existing technologies. In the case of the coronary sinus procedures, percutaneous access to the coronary sinus is technically difficult and time consuming to achieve, with procedures which may require several hours to properly access the coronary sinus. Moreover, these procedures employ incomplete annular rings, which compromise their physiologic effect. Such procedures are typically not effective for improving mitral regurgitation by more than one clinical grade. Finally, coronary sinus procedures carry the potentially disastrous risks of either fatal tears or catastrophic thrombosis of the coronary sinus.

[0017] Similarly, percutaneous procedures which employ sutures, clips, or other devices to affix the anterior mitral leaflets to the posterior mitral leaflets also have limited reparative capabilities. Such procedures are also typically ineffective in providing a complete repair of mitral regurgitation.. Furthermore, surgical experience indicates that such methods are not durable, with likely separation of the affixed valve leaflets. These procedures also fail to address the pathophysiology of the dilated mitral annulus in

ischemic heart disease. As a result of the residual anatomic pathology, no ventricular remodeling or improved ventricular function is likely with these procedures.

[0018] The need exists, therefore, for a delivery system and methods for its use that would avoid the need for open surgery in such exemplary circumstances, and allow delivery, placement, and adjustment of a prosthetic implant to reduce the diameter of such a mitral annulus in a percutaneous or other minimally invasive procedure, while still achieving clinical and physiologic results that are at least the equivalent of the yields of the best open surgical procedures for these same problems.

[0019] The preceding cardiac applications are only examples of some applications according to the present invention. Another exemplary application anticipated by the present invention is in the field of gastrointestinal surgery, where the aforementioned Nissen fundoplication procedure has long been used to narrow the gastro-esophageal junction for relief of gastric reflux into the esophagus. In this setting, a surgeon is conventionally faced with the tension between creating sufficient narrowing to achieve reflux control, but avoiding excessive narrowing that may interfere with the passage of nutrient contents from the esophagus into the stomach. Additionally, "gas bloat" may cause the inability to belch, a common complication of over-narrowing of the GE junction. An adjustable prosthetic implant according to the present invention could allow in situ adjustment in such a setting under physiologic assessment after primary surgical closure. Such an adjustable prosthetic implant according to the present invention could be placed endoscopically, percutaneously, or with an endoscope placed within a body cavity or organ, or by trans-abdominal or trans-thoracic approaches. In addition, such an adjustable prosthetic implant according to the present invention could be coupled with an adjustment means capable of being placed in the subcutaneous or other anatomic tissues within the body, such that remote adjustments could be made to the implant during physiologic function of the implant. This adjustment means can also be contained within the implant and adjusted remotely, i.e. remote control adjustment. Such an adjustment means might be capable of removal from the body, or might be retained within the body indefinitely for later adjustment.

[0020] The present invention and the methods for its use anticipate many alternate embodiments in other potential applications in the broad fields of medicine and surgery. Among the other potential applications anticipated according to the present invention are adjustable implants for use in the treatment of morbid obesity, urinary incontinence, anastomotic strictures, arterial stenosis, urinary incontinence, cervical incompetence, ductal

strictures, and anal incontinence. The preceding discussions are intended to be exemplary embodiments according to the present invention and should not be construed to limit the present invention and the methods for its use in any way.

SUMMARY OF THE INVENTION

[0021] In a first aspect, the present invention is directed to a novel prosthetic implant and method for use for adjusting the internal circumference of an anatomic passage that can be adjusted after implantation and after the resumption of normal flow of anatomic fluids in situ. In another aspect, the present invention is directed to a novel delivery system and methods for its use for the delivery and placement of a prosthetic implant within an anatomic site. Furthermore, the delivery system and methods according to the present invention are capable of in situ adjustment of such a prosthetic implant following its placement.

[0022] An adjustable prosthetic implant according to a first aspect of the present invention could allow in situ adjustment after initial narrowing of the circumference of an internal anatomic passage under physiologic assessment after primary surgical closure. Such an adjustable prosthetic implant according to the present invention could be placed through an open surgical incision, or it could be placed endoscopically, either percutaneously or with an endoscope placed within a body cavity or organ. In addition, such an adjustable prosthetic implant according to the present invention could be coupled with an adjustment means capable of being placed in the subcutaneous or other anatomic tissues within the body, such that remote adjustments could be made to the implant during physiologic function of the implant. Such an adjustment means might be capable of removal from the body, or might be retained within the body indefinitely for later adjustment.

[0023] The present invention and the methods for its use anticipate many alternate embodiments in other potential applications in the broad fields of medicine and surgery. Among the other potential applications anticipated according to the present invention are adjustable implants for use in the treatment of anal incontinence, urinary incontinence, anastomotic strictures, arterial stenosis, urinary incontinence, cervical incompetence, ductal strictures, morbid obesity, and for tricuspid valvular dysfunction. The preceding discussions are intended to be exemplary embodiments according to the present invention and should not be construed to limit the present invention and the methods for its use in any way.

[0024] In another exemplary application according to the present invention, a dysfunctional cardiac valve could be replaced or functionally supplemented to relieve disease without the need for open heart surgery by a delivery system and methods for use that would allow placement of a prosthetic heart valve by a similar percutaneous or other minimally invasive procedure.

[0025] Objects, features, and advantages of the present invention will become apparent upon reading the following specification, when taken in conjunction with the drawings and the appended claims.

BRIEF DESCRIPTION OF THE DRAWINGS

[0026] FIG. 1 is a front view of a first embodiment of an implant for reducing the circumference of an anatomic orifice.

[0027] FIG. 2 is a front view of the implant of FIG. 1 secured to the annulus of a mitral valve, with the implant in an expanded position.

[0028] FIG. 3 is a front view of the implant of FIG. 1 secured to the annulus of a mitral valve, with the implant in a contracted position to reduced the size of the heart valve opening.

[0029] FIG. 4 is a perspective view of a second embodiment of an implant for reducing the circumference of an anatomic orifice, inserted through an open operative cardiac incision and secured around the mitral valve.

[0030] FIG. 5 is a perspective view of the implant of FIG. 4, showing the cardiac incision closed, an adjustment tool extending through the closed incision, and adjustment of the implant possible after the patient has been taken "off pump."

[0031] FIG. 6 is a perspective view of a first embodiment of an adjustment means for adjusting the circumference of an implant for reducing the circumference of an anatomic orifice.

[0032] FIG. 7 is a right side view of the adjustment means of FIG. 6.

[0033] FIG. 8 is a left side view of the adjustment means of FIG. 6.

[0034] FIG. 9 is a right side view of a second embodiment of an adjustment means for adjusting the circumference of an implant for reducing the circumference of an anatomic orifice.

- [0035] FIG. 10 is a perspective view of a first alternate embodiment of an attachment means for the implant of FIG. 1.
- [0036] FIG. 11 is a perspective view of a second alternate embodiment of an attachment means for the implant of FIG. 1.
- [0037] FIG. 12 is a perspective view of a third embodiment of an implant for reducing the circumference of an anatomic orifice.
- [0038] FIG. 13 is a perspective view of one end of the implant of FIG. 12 showing an optional keyed relationship between three coaxial cannulae to prevent relative rotation between the three components.
- [0039] FIG. 14 is a perspective view of the implant of FIG. 12 showing the outer cannula extended to cover the implant.
- [0040] FIG. 15 is a perspective view of the implant of FIG. 12 showing the outer cannula retracted to expose the implant.
- [0041] FIG. 16 is a perspective view of the implant of FIG. 12 showing the middle cannula extended to unfold the implant.
- [0042] FIGS. 17 and 18 are schematic views illustrating how extension of the middle cannula causes the implant to unfold, where FIG. 17 shows the implant in the folded position, and FIG. 18 shows the implant in the unfolded position.
- [0043] FIG. 19 is a perspective view of the lower end of a touchdown sensor of the implant of FIG. 12, showing the sensor in an uncompressed condition.
- [0044] FIG. 20 is a perspective view of the lower end of the touchdown sensor of FIG. 19, showing the sensor in a compressed condition.
- [0045] FIG. 21 is a perspective end view of a fourth embodiment of an implant for reducing the circumference of an anatomic orifice.
- [0046] FIG. 22 is a side view of the implant of FIG. 21 with the implant opened up to show its full length.
- [0047] FIG. 23 is a side view of the adjustment mechanism of the implant of FIG. 21.
- [0048] FIG. 24 is a close-up view of two of the retention barbs of the implant of FIG. 21.
- [0049] FIG. 25 is a front view of a fifth embodiment of an implant for reducing the circumference of an anatomic orifice, with the implant shown in its expanded configuration.

- [0050] FIG. 26 is a front view of the implant of FIG. 25, with the implant shown in its contracted configuration.
- [0051] FIG. 27 is an enlarged view of the area indicated by the circle 27 in FIG. 25, with the outer body removed to show interior detail.
- [0052] FIG. 28 is a schematic view showing the implant of FIG. 12 anatomically positioned at the mitral annulus in a heart with the implant in a fully expanded state.
- [0053] FIG. 29 is a schematic view showing the implant of FIG. 12 anatomically positioned at the gastroesophageal opening with the implant in a fully expanded state.
- [0054] FIG. 30 is a schematic view showing the implant of FIG. 29 implanted to reduce the circumference of the gastroesophageal opening.
- [0055] FIG. 31 is a lateral view of a first embodiment of an adjustment means incorporating a magnetic docking system.
- [0056] FIG. 32 is an end view of the adjustment means of FIG. 31.
- [0057] FIG. 33a is a schematic view of a first embodiment of an adjustment tool incorporating a magnetic docking system.
- [0058] FIG. 33b is a schematic view of the adjustment tool of FIG. 33a, with a hex driver in a retracted state.
- [0059] FIG. 34 is a lateral view of a second embodiment of an adjustment means incorporating a magnetic docking system.
- [0060] FIG. 35 is an end view of the adjustment means of FIG. 34.
- [0061] FIG. 36a is a schematic view of a second embodiment of an adjustment tool incorporating a magnetic docking system.
- [0062] FIG. 36b is a schematic view of the adjustment tool of FIG. 36a, with a hex driver in a retracted state.
- [0063] FIGS. 37-42 show the procedure for inserting an adjustment tool via the right jugular vein and coupling the adjustment tool with an adjustment means using an embodiment of a magnetic docking system.

DETAILED DESCRIPTION OF THE DISCLOSED EMBODIMENT

[0064] Referring now to the drawings, in which like numerals indicate like elements throughout the several views, an exemplary implant 10 comprising an implant body 15 is shown in FIG. 1. The implant body may be provided in a shape and size determined by the

anatomic needs of an intended native recipient anatomic site within a mammalian patient. Such a native recipient anatomic site may be, by way of illustration and not by way of limitation, a heart valve, the esophagus near the gastro-esophageal junction, the anus, or other anatomic sites within a mammalian body that are creating dysfunction that might be relieved by an implant capable of changing the size and shape of that site and maintaining a desired size and shape after surgery.

[0065] The implant 10 of FIG. 1 comprises a circular implant body 15 which is provided with adjustable corrugated sections 20 alternating with intervening grommet-like attachment means 25 having narrowed intermediate neck portions. As can be seen in FIGS. 2 and 3, the implant body 15 may be secured to the annulus of a heart valve 30 by a fixation means such as a suture 35 secured over or through the attachment means 25. The corrugated sections 20 fold and unfold as the circumference of the implant body 15 shortens or lengthens. Adjustment of the implant 10 in situ may decrease the overall size of the heart valve 30, increasing the coaptation of the valve leaflets 40, and changing the configuration from that shown in FIG. 2 to that shown in FIG. 3.

[0066] An additional exemplary embodiment 100 of the present invention is shown in FIGS. 4 and 5, with an open operative cardiac incision 105 in a heart 110 shown in FIG. 4, and closure of the cardiac incision 105 in FIG. 5. As shown in FIG. 4, the exemplary adjustable implant 100 according to the present invention comprises an implant body 115 with attachment means 120 that allows fixation to the annulus of a mitral valve 125. The exemplary adjustable implant 100 is further provided with an adjustment means 130 that is controlled by an attached or coupled adjustment tool 135. After closure of the myocardial incision 105 in FIG. 5, the adjustment tool 135 remains attached or coupled to the adjustment means 130, so that the size and shape of the implant 100 may further be affected after physiologic flow through the heart 110 is resumed, but with the chest incision still open. Once the desired shape and function are achieved, the adjustment tool 135 may be disengaged from the adjustment means 130 and withdrawn from the myocardial incision 105. In various embodiments according to the present invention, the adjustment means 130 may be configured and placed to allow retention by or re-introduction of the adjustment tool 135 for adjustment following closure of the chest incision.

[0067] To use the implant 100 of FIGS. 4 and 5, the physician makes the open operative incision 105 in the heart 110, as shown in FIG. 4, in the conventional manner. The implant 100, mounted at the forward end of adjustment tool 135, is then advanced through

the incision 105 and sutured to the annulus of the mitral valve 125. The adjustment tool 135 is then manipulated, e.g., rotated, depending upon the design of the adjustment means 130, to cause the adjustment means to reduce the size of the implant body 115, and hence the underlying mitral valve 125 to which it is sutured, to an approximate size. The myocardial incision 105 can now be closed, as shown in FIG. 5, leaving the adjustment tool extending through the incision for post-operative adjustment.

[0068] Once the patient has been taken "off pump" and normal flow of blood through the heart 110 has resumed, but before the chest incision has been closed, further adjustments to the size of the mitral valve 125 can be made by manipulating the adjustment tool 135.

[0069] FIGS. 6-8 show an exemplary adjustment means 200 for adjusting the circumference of an annular implant such as the implant 100 previously described. The adjustment means 200 comprises a rack and pinion system in which a first cam 205 with geared teeth 210 and an engagement coupler 215 turns on a first axel 220. In this example, the first cam 205 engages a geared rack 225 on one or more surfaces of a first band 230. The first band 230 passes between the first cam 205 and a second cam 235 that turns on a second axel 240 that is joined to a second band 245. As shown in FIG. 8, the first and second axels 220, 240 are maintained in suitable spaced-apart relation by means of a bracket 250 formed at the end of the second band 245.

[0070] The adjustment means 200 is preferably set within a hollow annular implant 100 of the type previously described, though it is possible to use the adjustment means in a stand-alone configuration wherein the first and second bands 230, 245 are opposing ends of the same continuous annular structure. In either event, to adjust the length of an implant comprising the adjustment means 200, a tool such as a hex wrench engages the engagement coupler 215 on the first cam 205 and rotates the first cam in a counterclockwise direction as shown in FIG. 7, as indicated by the arrow 255. Rotation of the first cam 205 causes the teeth 210 to drive the rack 225 to move the first band 230 toward the right, as indicated by the arrow 260 in FIG. 7. This movement of the first band tightens the circumference of the annular implant. If the physician inadvertently adjusts the implant too tight, reversing direction of the engagement coupler 215 will loosen the implant.

[0071] In various embodiments according to the present invention, the first and second bands 230, 245 may be separate structures, or they may be opposing ends of the same continuous structure. In such an embodiment, when motion is imparted to the

engagement coupler 215, the first cam 205 is rotated, causing the geared teeth 210 to engage the geared rack 225, and causing the first band 230 to move with respect to the second band 245 to adjust the circumference of an implant.

[0072] FIG. 9 shows a somewhat different configuration of an exemplary engagement means 300 according to the present invention, in which there is no engagement coupler, and a bracket 350 is provided on both sides of the cams to maintain the first cam 315 and the second cam 320 in close approximation. In one proposed embodiment, the bracket is designed with close tolerances so as to press the first band 330 closely against the second band 345, thereby to hold the bands in fixed relative position by friction. In another proposed embodiment, the brackets 350 are fabricated from an elastic material such that the cams 315, 320 can be spread apart to insert the first band 330 between the cams, whereupon the cams are pulled back together with sufficient force to hold the bands 330, 345 in fixed relative position by friction. In still another proposed embodiment involving an elastic mounting arrangement between the cams 315, 320, the lower edge of the first band 330 and the upper edge of the second band 345 have mating frictional or mechanical surfaces, whereby the cams 315, 320 can be spread apart to permit relative movement between the bands or released to clamp the bands together in fixed relation.

[0073] FIG. 10 shows an exemplary attachment means 400 for an implant according to the present invention. The attachment means 400 could be used, for example, in place of the attachment means 25 of the implant 10. The attachment means 400 takes the form of a grommet 410 comprising a wall 415 defining a lumen 420 and an attachment surface 425. Such an attachment means would be used with the implant body extending through the lumen 420 and with fixation devices such as sutures or wires either tied over or affixed through the attachment surface 425.

[0074] FIG. 11 shows another alternate embodiment of an attachment means 500 for an implant according to the present invention. The attachment means 500 could also be used, for example, in place of the attachment means 25 of the implant 10. FIG. 11 shows an attachment means 500 in the form of a hollow tube or tube segment 510 comprising a wall 515 defining a lumen 520, an outer surface 525, and an attachment tab 530. Such an attachment means would be used with the implant body extending through the lumen 520 and with fixation devices such as sutures or wires either tied or otherwise affixed over or through the attachment tab 530. Such fixation devices might be placed through holes 535 provided in the attachment tab 530. Alternately a solid attachment tab 530 might be

provided, and the fixation devices might be passed through the solid tab. Modifications of these attachment means may be used in conjunction with a sutureless attachment system.

[0075] FIGS. 12-18 show another embodiment of a percutaneous annuloplasty device according to the present invention, in which an implant/delivery system array 600 includes a housing sheath 605 (not seen in FIG. 12), an actuating catheter 610 coaxially slidably mounted within the housing sheath 605, and a core catheter 615 coaxially slidably mounted within the actuating catheter 610. The core catheter has a central lumen 616 (FIG. 13). The actuating catheter 610 and core catheter 615 may be round tubular structures, or as shown in FIG. 13, either or both of the actuating and core catheters may be provided with one or more keyed ridges 618, 620 respectively to be received by one or more reciprocal slots 622, 624 within the inner lumen of either the housing sheath 605 or the actuating catheter 610, respectively. Such keyed ridges 618, 620 would limit internal rotation of an inner element within an outer element, should such restriction be desirable to maintain control of the inner contents from inadvertent displacement due to undesired rotational motion during use.

[0076] The implant/delivery system array 600 includes a distal tip 625 at the forward end of the core catheter 615. One or more radial implant support arms 630 have their distal ends 632 pivotably or bendably mounted to the core catheter 615 adjacent its distal tip 625. The proximal ends 634 of the radial implant support arms 630 normally extend along the core catheter 615 but are capable of being displaced outward away from the core catheter.

[0077] One or more radial support struts 636 have their proximal ends 638 pivotably or bendably mounted to the distal end of the actuating catheter 610. The distal end 640 of each radial support strut is 636 pivotably or bendably attached to a midpoint of a corresponding radial implant support arm 630. As the actuating catheter 610 is advanced with respect to the core catheter 615, the radial support struts 636 force the radial implant support arms 630 upward and outward in the fashion of an umbrella frame. Thus, the actuating catheter 610, core catheter 615, radial support struts 636, and radial support arms 630 in combination form a deployment umbrella 642.

[0078] A prosthetic implant 645 is releasably attached to the proximal ends 634 of the radial implant support arms 630. Around the periphery of the prosthetic implant 645 and extending proximally therefrom are a plurality of retention barbs 646. In addition, one or more of the radial implant support arms 630 comprise touchdown sensors 648 whose

proximal ends extend proximal to the implant 645. Extending through the central lumen 616 (FIG. 13) of the core catheter 615 in the exemplary embodiment 600 and out lateral ports 650 (FIG. 12) spaced proximally from the distal tip 625 are one or more release elements 660, which serve to release the implant 645 from the delivery system, and one or more adjustment elements 665 which serve to adjust the implant's deployed size and effect. Because the release elements 660 and adjustment elements 665 extend through the proximal end of the core catheter 615, as seen in FIGS. 14-16, these elements can be directly or indirectly instrumented or manipulated by the physician. A delivery interface 670 (FIGS. 12,16) is defined in this example by the interaction of the deployment umbrella 642, the release elements 660, and the implant 645. In the disclosed embodiment, the release elements 660 may be a suture, fiber, or wire in a continuous loop that passes through laser-drilled bores in the implant 645 and in the radial implant support arms 630, and then passes through the length of the core catheter 615. In such an embodiment, the implant 645 may be released from the delivery system at a desired time by severing the release element 660 at its proximal end, outside the patient, and then withdrawing the free end of the release element 660 through the core catheter 610.

[0079] FIGS. 14-16 show the operation of the implant/delivery system array 600, in which an umbrella-like expansion of the prosthetic implant 645 is achieved by sliding movement of the housing sheath 605, the actuating catheter 610, and the core catheter 615. Referring first to FIG. 14, the housing sheath 605 is extended to cover the forward ends of the actuating catheter 610 and core catheter 615 for intravascular insertion of the implant/delivery system array 600. From this starting position, the housing sheath 605 is retracted in the direction indicated by the arrows 662. In FIG. 15 the housing sheath 605 has been retracted to expose the forward end of the actuating catheter 610 and the collapsed deployment umbrella 642. From this position the actuating catheter 610 is advanced in the direction indicated by the arrows 664. This will cause the deployment umbrellas to expand in the directions indicated by the arrows 666. FIG. 16 shows the expansion of the deployment umbrella 642 produced by distal motion of the actuating catheter 610 relative to the core catheter 615. After the implant 645 has been positioned and adjusted to the proper size, the housing sheath 605 is advanced in the direction indicated by the arrows 668 to collapse and to cover the deployment umbrella 642 for withdrawal of the device from the patient.

[0080] FIGS. 17 and 18 are schematic views illustrating the radial implant support arms 630 and the radial support struts 636 of the implant/delivery system array 600. In FIG. 17, a radial support strut 636 is pivotably attached at its proximal end 638 at a first pivotable joint 670 to the actuation catheter 610. The radial support strut 636 is attached at its distal end 640 to a second pivotable joint 672 at an intermediate point of a corresponding radial implant support arm 630. The radial implant support arm 630 is attached at its distal end 632 by a third pivotable joint 674 to the core catheter 620. FIG. 17 shows the assembly in a closed state. When the actuation catheter 610 is advanced distally over the core catheter 615, as shown by the arrows 676, the radial support strut 636 and the radial implant support arm 630 are extended by the motion at the first pivotable joint 670, the second pivotable joint 672, and the third pivotable joint 674, as shown by the arrow 678. This motion has the effect of expanding the deployment umbrella and folded implant (not shown in FIGS. 17 and 18), allowing it to achieve its greatest radial dimension, prior to engagement and implantation as previously discussed with reference to FIGS. 12-16.

[0081] FIGS. 19 and 20 show further details of the touchdown sensors 648 shown previously in FIG. 12. The touchdown sensor 648 of FIGS. 19 and 20 includes a distal segment 680, an intermediate segment 682, and a proximal segment 684. The distal segment 680 is spring-mounted, so that it is capable of slidable, telescoping displacement over the intermediate segment 682 to achieve a seamless junction with the proximal segment 684 upon maximal displacement. When the touchdown sensor 648 is in its normal condition, the spring extends the proximal segment such that the sensor assumes the orientation shown in FIG. 19. When the implant 645 (FIG. 12) is seated against the periphery of an anatomical opening, the proximal segment 684 of the sensor 648 is compressed against the distal segment 680, as shown in FIG. 20. The distal segment 680 and the proximal segment 684 are both constructed of, are sheathed by, or otherwise covered with a radio-opaque material. However, the intermediate segment 682 is not constructed or coated with such a radio-opaque material. Therefore, when the distal segment 680 is at rest, it is fully extended from the proximal segment 684, and the gap represented by the exposed intermediate segment 682 is visible on radiographic examination. However, when the distal segment 680 is brought to maximum closeness with the proximal segment 684, no such radio-opaque gap is radiographically visible, and the touchdown sensor is said to be "activated". This embodiment allows radiographic monitoring of the position of the touchdown sensor 648 with respect to the degree of extension of the distal catheter segment 680. In the

embodiment according to the present invention as shown, one or more touchdown detectors 648 are employed to ascertain that the delivery system for the prosthetic device is located in the proper position to deploy the implant into the mitral annulus. As this anatomic structure cannot be directly identified on fluoroscopy or standard radiographic procedures, such precise location could be otherwise difficult. At the same time, precise localization and engagement of the mitral annulus is critical for proper implant function and safety.

[0082] Touchdown detectors within the embodiments according to the present invention can have a multiplicity of forms, including the telescoping, spring-loaded, radio-opaque elements joined by a non-radio-opaque element as in the aforementioned examples. In embodiments employing magnetic resonance imaging, touchdown detectors according to the present invention may utilize metallic segments interposed by nonmetallic segments in a similar telescoping, spring-loaded array. Other embodiments include a visually-evident system with telescoping, spring-loaded elements with color-coded or other visual features for procedures in which direct or endoscopic observation would be possible. Still other embodiments of touchdown detectors according to the present invention include touchdown detectors provided with microswitches at their tips, such that momentary contact of sufficient pressure completes an electrical circuit and signals the activation of the touchdown detector to the operator. Still other touchdown detectors according to the present invention are provided with fiberoptic pathways for Raman laser spectroscopy or other spectral analytical techniques which are capable of detecting unique tissue qualities of the tissue at the desired site for implantation. In addition, still other embodiments according to the present invention include touchdown detectors containing electrodes or other electronic sensors capable of detecting and signaling the operator when a desired electrophysiologic, impedance, or other measurable quality of the desired tissue is detected for proper implantation. Such electrophysiologic touchdown detectors may include electrical circuits that produce visual, auditory, or other signals to the operator that the detectors are activated and that the implant is in the proper position for attachment.

[0083] In yet other embodiments according to the present invention, other intracardiac or extracardiac imaging techniques including, but not limited to, intravascular ultrasound, nuclear magnetic resonance, virtual anatomic positioning systems, or other imaging techniques may be employed to confirm proper positioning of the implant, obviating the need for the touchdown sensors as previously described.

[0084] FIGS. 21-24 show an implant 700 according to one embodiment of the present invention. In this embodiment, the implant body 705 is bandlike and flexible. Through much of its length, the implant body 705 is provided with a series of retention barbs 710 which are oriented to facilitate placement, retention, and removal of the device. The implant body 705 is also provided with an adjustable section 715, which is provided in this example with a series of adjustment stops 720. The adjustment stops 720 may be slots, holes, detents, dimples, ridges, teeth, raised elements, or other mechanical features to allow measured adjustment of the implant 700 in use. In the embodiment shown in FIGS. 21-24, the adjustment stops 720 are engaged by a geared connector 725. FIG. 21 is an end view, showing the implant body 705 curved on itself, with the retention barbs 710 to the exterior, and with the adjustable section 715 passing through its engagement with the geared connector 725 and curving internally within the implant body 705 to form a closed, round structure. FIG. 23 shows details of an exemplary geared connector 725, in which a housing 730 is connected to the implant body 705. The housing 730 contains and supports a mechanical worm 740 with an attached first geared head 750 which mates with a second geared head 755. The second geared head 755 is attached to an adjustment stem 760 which is machined to receive a screwdriver-like adjustment element. The various embodiments according to the present invention may require a number of forms of adjustment elements. In the present example, the adjustment element is provided as a finely coiled wire with a distal tip machined to be received by a receiving slot in the adjustment stem 760 (not shown). The relationship between the distal tip of the adjustment element and the adjustment stem 760 is mechanically similar to a screwdriver bit and screwhead, such that torsion imparted to the adjustment means by the operator will result in the turning of the adjustment stem 760 and second geared head 755 allows motion of the first geared head 750 and worm 740, which creates motion of the adjustable implant section 715 as the worm engages with the series of adjustment tops 725. Excess length of the adjustable section 715 passes through a band slot 735 (FIG. 23), thus allowing the band to move concentrically inside the closed implant body 705. The adjustment element in this embodiment may be designed to remain in place after the deployment umbrella has been retracted and withdrawn. The connection between the adjustment element's distal tip and the adjustment stem 760 may be a simple friction connection, a mechanical key/slot formation, or may be magnetically or electronically maintained.

[0085] As further shown in FIG. 21, the exemplary embodiment employs unidirectional retention barbs 710 which are attached to the outer perimeter of the implant body 705. The retention barbs 710 are oriented in a consistent, tangential position with respect to the implant body 705 such that rotational motion of the implant body will either engage or release the retention barbs 710 upon contact with the desired tissue at the time of deployment. This positioning of the retention barbs 710 allows the operator to "screw in" the implant 700 by turning the implant 700 upon its axis, thus engaging the retention barbs 710 into the adjacent tissue. As shown in FIG. 24, the retention barbs 710 may each be further provided with a terminal hook 775 at the end which would allow for smooth passage through tissue when engaging the retention barbs 710 by rotating the implant 700, without permitting the implant 700 to rotate in the opposite direction, because of the action of the terminal hooks 775 grasping the surrounding tissue (much like barbed fish hooks). The terminal hooks 775 thus ensure the seating of the implant 700 into the surrounding tissue.

[0086] FIGS. 25-27 illustrate another embodiment of an implant 800 as contemplated according to the present invention. The implant 800 includes a band 805 (FIG. 27), but the retention barbs of the previous example have been eliminated in favor of an outer fabric implant sheath 810. The fabric sheath 810 can be sutured or otherwise affixed to the anatomic tissue in a desired location. The circumference of the implant body 800 is adjusted through a geared connector 825 similar to the geared connector of the bandlike implant array shown in FIG. 23. More specifically, adjustment stops 820 on the band are engaged by a mechanical worm 840 with an attached first geared head 850. The first geared head 850 mates with a second geared head 855. The second geared head 855 is attached to an adjustment stem 860 which is machined to receive a screwdriver-like adjustment element.

[0087] FIG. 28 illustrates an example of the method of use of an implant/delivery system array 600 for positioning an implant 645 in a patient with ischemic annular dilatation and mitral regurgitation. Peripheral arterial access is obtained via conventional cutdown, arterial puncture, or other standard access techniques. After access to the arterial system is attained, guidewire placement is performed and intravascular access to the heart 900 is obtained using fluoroscopic, ultrasound, three-dimension ultrasound, magnetic resonance, or other real-time imaging techniques. The guidewire, deployment device, and implant are passed through the aortic valve in a retrograde fashion into the left ventricle 905 and then into the left atrium 910. At this point, the operator retracts the housing sheath 605, thus unsheathing the collapsed deployment umbrella 642 and implant 645. The deployment

umbrella 642 is then distended by the distal motion of the actuation catheter, causing the radial support arms and struts to fully distend. At this point, the touchdown detectors 648 are not in contact with any solid structures, and are fully extended with their radiolucent gaps visible on the imaging system. Once the deployment umbrella is distended, the entire assembly is pulled back against the area of the mitral valve 915. At least two touchdown detectors 648 are employed in a preferred embodiment according to the present invention. When all touchdown detectors show the disappearance of their intermediate, non-opaque, intermediate segments and are thus activated, then the deployment umbrella must be in contact with the solid tissue in the region of the mitral annulus/atrial tissue, and further implant deployment and adjustment may proceed. However, if any one touchdown sensor is not activated, and a radiolucent gap persists, then the device is not properly positioned, and must be repositioned before further deployment. Thus, the touchdown sensor system may assist in the deployment and adjustment of prosthetic devices by the delivery system according to the present invention. Once properly positioned, the operator rotates the actuation catheter in a prescribed clockwise or counterclockwise manner to engage the retention barbs on the implant into the tissue in the region of the mitral annulus/atrial tissue. Should re-positioning be required, a reverse motion would disengage the retention barbs from the annular/atrial tissue, and repositioning may be performed, again using the touchdown detectors for proper placement. Once firmly seated, the adjustment element(s) are operated to achieve the desired degree of annular reduction. Real-time trans esophageal echocardiography, intravascular echocardiography, intracardiac echocardiography, or other modalities for assessing mitral function may then be employed to assess the physiologic effect of the repair on mitral function, and additional adjustments may be performed. Once a desired result has been achieved, the release elements are activated to detach the implant from the deployment umbrella. The operator then retracts the actuation catheter and extends the housing sheath, collapsing the deployment umbrella and covering the components for a smooth and atraumatic withdrawal of the device from the heart and vascular system.

[0088] If desired, the adjustment elements may be left in position after the catheter components are withdrawn for further physiologic adjustment. In yet other embodiments according to the present invention, a catheter-based adjustment elements may subsequently be re-inserted though a percutaneous or other route. Such an adjustment element may be steerably operable by the operator, and may be provided with magnetic, electronic, electromagnetic, or laser-guided systems to allow docking of the adjustment element with

the adjustable mechanism contained within the implant. In still other embodiments, the adjustment mechanism may be driven by implanted electromechanical motors or other systems, which may be remotely controlled by electronic flux or other remote transcutaneous or percutaneous methods.

[0089] In the case of pulmonic valve repair, initial catheter access is achieved through a peripheral or central vein. Access to the pulmonary valve is also achieved from below the valve once central venous access is achieved by traversing the right atrium, the tricuspid valve, the right ventricle, and subsequently reaching the pulmonic valve.

[0090] In yet other embodiments according to the present invention, catheter access to the left atrium can be achieved from cannulation of central or peripheral veins, thereby achieving access to the right atrium. Then a standard atrial trans-septal approach may be utilized to access the left atrium by creation of an iatrogenic atrial septal defect (ASD). In such a situation, the mitral valve may be accessed from above the valve, as opposed to the retrograde access described in Example 1. The implant and a reversed deployment umbrella may be utilized with implant placement in the atrial aspect of the mitral annulus, with the same repair technique described previously. The iatrogenic ASD may then be closed using standard device methods. Access to the aortic valve may also be achieved from above the aortic valve via arterial access in a similar retrograde fashion.

[0091] Other embodiments of the adjustable implant and methods according to the present invention include gastrointestinal disorders such as gastro-esophageal reflux disease (GERD), a condition in which the gastro-esophageal (GE) junction lacks adequate sphincter tone to prevent the reflux of stomach contents into the esophagus, causing classic heartburn or acid reflux. This not only results in discomfort, but may cause trauma to the lower esophagus over time that may lead to the development of pre-cancerous lesions (Barrett's esophagus) or adenocarcinoma of the esophagus at the GE junction. Surgical repair of the GE junction has historically been achieved with the Nissen Fundoplication, an operative procedure with generally good results. However, the Nissen procedure requires general anesthesia and a hospital stay. Utilizing the devices and methods according to the present invention, an adjustable implant would obviate the need for a hospital stay and be performed in a clinic or gastroenterologist's office. Referring now to FIGS. 29 and 30, an umbrella deployment device 600 with implant 645 is passed under guidance of an endoscope 1000, through the patient's mouth, esophagus 1005, and into the stomach 1010, where the deployment device 600 is opened with expansion of the implant 645 and

touchdown detectors 648 with a color-coded or otherwise visible gap. The touchdown detectors are then engaged onto the stomach around the gastroesophageal junction 1015 under direct endoscopic control until all touchdown detectors 648 are visually activated. The implant is then attached to the stomach wall, 1020 the umbrella 642 is released and withdrawn, leaving behind the implant 645 and the adjustment elements. The implant is then adjusted until the desired effect is achieved, i.e., minimal acid reflux either by patient symptoms, pH monitoring of the esophagus, imaging studies, or other diagnostic means. If the patient should suffer from gas bloat, a common complication of gastroesophageal junction repair in which the repair is too tight and the patient is unable to belch, the implant can be loosened until a more desirable effect is achieved.

[0092] In various embodiments anticipated by the present invention, the implant body may be straight, curved, circular, ovoid, polygonal, or some combination thereof. In various embodiments anticipated by the present invention the implant may be capable of providing a uniform or non-uniform adjustment of an orifice or lumen within the body. The implant body may further completely enclose the native recipient anatomic site, or it may be provided in an interrupted form that encloses only a portion of the native recipient anatomic site. In still other embodiments of the present invention, the implant body may be a solid structure, while in yet other embodiments the implant body may form a tubular or otherwise hollow structure. In one embodiment of the present invention, the body may further be a structure with an outer member, an inner member, and optional attachment members. In such an embodiment, the outer member of the implant body may serve as a covering for the implant, and is designed to facilitate and promote tissue ingrowth and biologic integration to the native recipient anatomic site. The outer member in such an embodiment may be fabricated of a biologically compatible material, such as Dacron, PTFE, malleable metals, other biologically compatible materials or a combination of such biologically compatible materials in a molded, woven, or non-woven configuration. The outer member in such an embodiment also serves to house the inner member. In this embodiment, the inner member provides an adjustment means that, when operated by an adjustment mechanism, is capable of altering the shape and/or size of the outer member in a defined manner.

[0093] In alternate embodiments according to the present invention, the adjustment means may be located external to or incorporated within the outer member. In yet additional alternate embodiments contemplated by the present invention, the implant body may consist of an adjustment means without a separate outer member covering said adjustment means.

[0094] In various embodiments according to the present invention, the adjustment means may include a mechanism which may be threaded or non-threaded, and which may be engaged by the action of a screw or worm screw, a friction mechanism, a friction-detent mechanism, a toothed mechanism, a ratchet mechanism, a rack and pinion mechanism, or such other devices to permit discreet adjustment and retention of desired size a desired position, once the proper size is determined.

[0095] In yet other embodiments according to the present invention, the adjustment means may comprise a snare or purse string-like mechanism in which a suture, a band, a wire or other fiber structure, braided or non-braided, monofilament or multifilament, is capable of affecting the anatomic and/or physiologic effects of the implant device on a native anatomic recipient site upon varying tension or motion imparted to said wire or fiber structure by a surgeon or other operator. Such an adjustment means may be provided as a circular or non-circular structure in various embodiments. Changes in tension or motion may change the size and/or shape of the implant.

[0096] In various embodiments according to the present invention, the adjustment means may be a metallic, plastic, synthetic, natural, biologic, or any other biologically-compatible material, or combination thereof. Such adjustment means may further be fabricated by extrusion or other molding techniques, machined, or woven. Furthermore, in various embodiments of the present invention, the adjustment means may be smooth or may include slots, beads, ridges, or any other smooth or textured surface.

[0097] In various embodiments of the present invention, the implant body may be provided with one or more attachment members such as grommets or openings or other attachment members to facilitate attachment of the implant to the native recipient site. In alternate embodiments, the implant body may attach to or incorporate a mechanical tissue interface system that allows a sutureless mechanical means of securing the implant at the native recipient site. In still other alternate embodiments, sutures or other attachment means may be secured around or through the implant body to affix the implant body to the native recipient site. In yet other embodiments of the present invention, mechanical means of securing the implant body to the native recipient site may be augmented or replaced by use of fibrin or other biologically-compatible tissue glues or similar adhesives.

[0098] In additional various embodiments according to the present invention, the adjustable implant may be employed to adjustably enlarge or maintain the circumference or

other dimensions of an orifice, ostium, lumen, or anastomosis in which a disease process tends to narrow or constrict such circumference or other dimensions.

[0099] In various embodiments according to the present invention, an adjustment mechanism may be provided to interact with the adjustment means to achieve the desired alteration in the size and/or position of the adjustment means. Such an adjustment mechanism may include one or more screws, worm-screw arrays rollers, gears, frictional stops, a friction-detent system, ratchets, rack and pinion arrays, micro-electromechanical systems, other mechanical or electromechanical devices or some combination thereof.

[00100] In some embodiments as contemplated by the present invention, an adjustment tool may be removably or permanently attached to the adjustment mechanism and disposed to impart motion to the adjustment mechanism and, in turn, to the adjustment means to increase or decrease the anatomic effect of the implant on the native recipient site.

[00101] In alternate embodiments according to the present invention, micromotor arrays with one or more micro-electromechanical motor systems with related electronic control circuitry may be provided as an adjustment means, and may be activated by remote control through signals conveyed by electromagnetic radiation or by direct circuitry through electronic conduit leads that may be either permanently or removably attached to said micromotor arrays.

[00102] In still other various embodiments according to the present invention, the adjustment mechanism may be provided with a locking mechanism disposed to maintain the position of the adjustment means in a selected position upon achievement of the optimally desired anatomic and/or physiologic effect upon the native recipient site and the bodily organ to which it belongs. In other embodiments, no special locking mechanism may be necessary due to the nature of the adjustment means employed.

[00103] In yet other alternate embodiments according to the present invention, the adjustment means and/or the outer member structure may be a pliable synthetic material capable of rigidification upon exposure to electromagnetic radiation of selected wavelength, such as ultraviolet light. In such embodiments, exposure to the desired electromagnetic radiation may be achieved by external delivery of such radiation to the implant by the surgeon, or by internal delivery of such radiation within an outer implant member using fiberoptic carriers placed within said outer member and connected to an appropriate external radiation source. Such fiberoptic carriers may be disposed for their removal in whole or in

part from the outer implant member after suitable radiation exposure and hardening of said adjustment means.

[00104] The present invention also provides methods of using an adjustable implant device to selectively alter the anatomic structure and/or physiologic effects of tissues forming a passageway for blood, other bodily fluids, nutrient fluids, semi-solids, or solids, or wastes within a mammalian body. Various embodiments for such uses of adjustable implants include, but are not limited to, open surgical placement of said adjustable implants at the native recipient site through an open surgical incision, percutaneous or intravascular placement of said implants under visual control employing fluoroscopic, ultrasound, magnetic resonance imaging, or other imaging technologies, placement of said implants through tissue structural walls, such as the coronary sinus or esophageal walls, or methods employing some combination of the above techniques. In various embodiments as contemplated by the present invention, adjustable implants may be placed and affixed in position in a native recipient anatomic site by trans-atrial, trans-ventricular, trans-arterial, trans-venous (i.e., via the pulmonary veins) or other routes during beating or non-beating cardiac surgical procedures or endoscopically or percutaneously in gastrointestinal surgery.

[00105] Furthermore, alternate methods for use of an adjustable implant device may provide for the periodic, post-implantation adjustment of the size of the anatomic structure receiving said implant device as needed to accommodate growth of the native recipient site in a juvenile patient or other changes in the physiologic needs of the recipient patient.

[00106] Adjustment of the adjustable implants and the methods for their use as disclosed herein contemplates the use by the surgeon or operator of diagnostic tools to provide an assessment of the nature of adjustment needed to achieve a desired effect. Such diagnostic tools include, but are not limited to, transesophageal echocardiography, echocardiography, diagnostic ultrasound, intravascular ultrasound, virtual anatomic positioning systems integrated with magnetic resonance, computerized tomographic, or other imaging technologies, endoscopy, mediastinoscopy, laparoscopy, thoracoscopy, radiography, fluoroscopy, magnetic resonance imaging, computerized tomographic imaging, intravascular flow sensors, thermal sensors or imaging, remote chemical or spectral analysis, or other imaging or quantitative or qualitative analytic systems.

[00107] In one aspect, the implant/delivery system of the present invention comprises a collapsible, compressible, or distensible prosthetic implant and a delivery interface for such a prosthetic implant that is capable of delivering the prosthetic implant to a desired

anatomic recipient site in a collapsed, compressed, or non-distended state, and then allowing controlled expansion or distension and physical attachment of such a prosthetic implant by a user at the desired anatomic recipient site. Such a system permits the delivery system and prosthetic implant to be introduced percutaneously through a trocar, sheath, via Seldinger technique, needle, or endoscopically through a natural bodily orifice, body cavity, or region and maneuvered by the surgeon or operator to the desired anatomic recipient site, where the delivery system and prosthetic implant may be operably expanded for deployment. When desirable, the implant/delivery system according to the present invention is also capable of allowing the user to further adjust the size or shape of the prosthetic implant once it has been attached to the desired anatomic recipient site. The delivery system according to the present invention is then capable of detaching from its interface with the prosthetic implant and being removed from the anatomic site by the operator. The delivery system and prosthetic implant may be provided in a shape and size determined by the anatomic needs of an intended native recipient anatomic site within a mammalian patient. Such a native recipient anatomic site may be a heart valve, the esophagus near the gastro-esophageal junction, the anus, or other anatomic sites within a mammalian body that are creating dysfunction that might be relieved by an implant capable of changing the size and shape of that site and maintaining a desired size and shape after surgery.

[00108] In various embodiments contemplated by the present invention, the delivery system may be a catheter, wire, filament, rod, tube, endoscope, or other mechanism capable of reaching the desired recipient anatomic site through an incision, puncture, trocar, or through an anatomic passageway such as a vessel, orifice, or organ lumen, or trans-abdominally or trans-thoracically. In various embodiments according to the present invention, the delivery system may be steerable by the operator. The delivery system may further have a delivery interface that would retain and convey a prosthetic implant to the desired recipient anatomic site. Such a delivery interface may be operably capable of distending, reshaping, or allowing the independent distension or expansion of such a prosthetic implant at the desired recipient anatomic site. Furthermore, such a delivery interface may provide an operable means to adjust the distended or expanded size, shape, or physiologic effect of the prosthetic implant once said implant has been attached in situ at the desired recipient anatomic site. In various embodiments according to the present invention, such adjustment may be carried out during the procedure in which the implant is placed, or at a subsequent time. Depending upon the specific anatomic needs of a specific application,

the delivery interface and the associated prosthetic implant may be straight, curved, circular, helical, tubular, ovoid, polygonal, or some combination thereof. In still other embodiments of the present invention, the prosthetic implant may be a solid structure, while in yet other embodiments the prosthetic implant may form a tubular, composite, or otherwise hollow structure. In one embodiment of the present invention, the prosthetic implant may further be a structure with an outer member, an inner member, and optional attachment members. In such an embodiment, the outer member of the prosthetic implant may serve as a covering for the implant, and is designed to facilitate and promote tissue ingrowth and biologic integration to the native recipient anatomic site. The outer member in such an embodiment may be fabricated of a biologically compatible material, such as Dacron, PTFE, malleable metals, other biologically compatible materials or a combination of such biologically compatible materials in a molded, woven, or non-woven configuration. The outer member in such an embodiment also serves to house the inner member. In this embodiment, the inner member provides an adjustment means that, when operated by an adjustment mechanism, is capable of altering the shape and/or size of the outer member in a defined manner.

[00109] In some embodiments according to the present invention, at least some portions of the adjustable inner or outer member may be elastic to provide an element of variable, artificial muscle tone to a valve, sphincter, orifice, or lumen in settings where such variability would be functionally valuable, such as in the treatment of rectal incontinence or vaginal prolapse.

[00110] In various embodiments according to the present invention, the delivery interface would have an attachment means to retain and convey the prosthetic implant en route to the native anatomic recipient site and during any in situ adjustment of the prosthetic implant once it has been placed by the operator. Such an attachment means would be operably reversible to allow detachment of the prosthetic implant from the delivery interface once desired placement and adjustment of the prosthetic implant has been accomplished.

[00111] As mentioned above, according to the present invention, an adjustment tool may be inserted though a percutaneous or other route and coupled with an adjustment means of the implant. In one aspect of the present invention, a magnetic docking system may be used to aid in the coupling or re-coupling of the adjustment tool with the adjustment

means. Consistent with this aspect of the present invention, FIGS. 31-36 show embodiments of such a magnetic docking system.

[00112] FIGS. 31-33 show one embodiment of the present invention in which the adjustment tool can be coupled to the adjustment means using a magnetic docking system. FIG. 31 is a lateral view of adjustment means 1130 that comprises gears 1103 inside a housing 1104. The adjustment means 1130 further comprises an internal hex 1101 that can drive the gears 1103, which in turn can adjust the size and/or shape of the implant. Specific details regarding the adjustment of the size and/or shape of the implant using the adjustment means 1130 are provided above, with respect to FIGS. 6-9. It is contemplated that the magnetic docking system of the present invention can be used with any of the methods or systems for adjusting the size and/or shape of the implant that were previously described herein or that are otherwise known in the art. Turning now to the magnetic docking aspect of the present invention, the adjustment means 1130 includes an interface location 1120 that enables the coupling of an adjustment tool. In the embodiment shown in FIG. 31, a magnetic docking collar 1102 is located along the internal surface of the interface location 1120. The magnetic docking collar 1102 is preferably comprised of a ferromagnetic material, but any magnetic material that is consistent with the purpose of the present invention can be used. The function of the magnetic docking collar 1102 will be further described below.

[00113] FIG. 32 is an end view of the adjustment means 1130 shown in FIG. 31. As discussed above, the adjustment means 1130 comprises an internal hex 1101, a magnetic docking collar 1102, gears 1103 for adjusting the implant, and a housing 1104.

[00114] FIGS. 33a and 33b show an embodiment of an adjustment tool 1135 designed to couple with the interface location 1120 of the adjustment means 1130. A distal end of the adjustment tool 1135 comprises a magnetic docking element 1105 and a hex driver 1106. As shown in FIGS. 33a and 33b, the magnetic docking element 1105 is located along a distal tip of the adjustment tool 1135. The magnetic docking element 1105 preferably comprises an electromagnet, but can be any type of magnet that is consistent with the purpose of the present invention. In a particular embodiment of the present invention where the magnetic docking element 1105 comprises an electromagnet, the adjustment tool 1135 also preferably includes an electromagnetic winding 1110, as shown in FIGS. 33a and 33b. The magnetic docking element 1105 is used to aid in coupling or re-coupling the adjustment tool 1135 with the adjustment means 1130. More specifically, the magnetic

docking element 1105 of the adjustment tool 1135 and the magnetic docking collar 1102 of the adjustment means 1130 are selected so that an attractive force will be generated when they are placed within a particular proximity of one another. The attractive force generated between the magnetic docking element 1105 and the magnetic docking collar 1102 will pull the distal end of the adjustment tool 1135 toward the adjustment means 1130 and guide it into the interface location 1120. For example, in a particular embodiment of the present invention where the magnetic docking element 1105 comprises an electromagnet, the adjustment tool 1135 is first manually guided to a location near the adjustment means 1130. Then, the electromagnet is turned on using a switch and an attractive force is generated between the electromagnet and the magnetic docking collar 1102 of the adjustment means 1130. This attractive force pulls the adjustment tool 1135 toward the adjustment means 1130 and guides it into the interface location 1120. Once coupled, the attractive force generated between the magnetic docking element 1105 and the magnetic docking collar 1102 will keep the adjustment tool 1135 and the adjustment means 1130 locked together.

[00115] The adjustment tool 1135 further comprises a hex driver 1106, as shown in FIGS. 33a and 33b. The hex driver 1106 is used to drive the internal hex 1101 of the adjustment means 1130, which in turn causes the gears 1103 to adjust the shape and/or size of the implant. The hex driver 1106 can be retracted within the adjustment tool 1135 while the tool is being inserted into the body (see FIG. 33b) and extended outward from the distal end of the adjustment tool 1135 when the tool is coupled with the adjustment means 1130 (see FIG. 33a). For example, after the adjustment tool 1135 has been coupled to the interface location 1120 using the magnetic docking system of the present invention, the hex driver 1106 can be extended until functionally connected to the internal hex 1101 and then rotated in order to actuate the gears 1103 and adjust the size and/or shape of the implant. The extension or retraction of the hex driver 1106 is accomplished by pushing or pulling the hex driver handle 1111, respectively, which causes the hex driver shaft 1112 to move. In one embodiment of the present invention, extension of the hex driver 1106 is limited to the distance needed to actuate the gears 1103, using a limiting collar 1109. Once the adjustment tool 1135 is coupled to the adjustment means 1130 and the hex driver 1106 is extended into a functional connection with the internal hex 1101, the hex driver 1106 may be operated by holding the adjustment tool handle 1108 (which may be rough for increased grip) and rotating the hex driver tool handle 1111 (which may also have a rough surface for better control and grip). Rotation of the hex driver handle 1111 will cause the internal hex

1101 to drive the gears 1103, which in turn causes adjustment of the shape and/or size of the implant. As discussed above with respect to FIGS. 6-9, the direction of rotation will determine whether the implant increases or decreases in size. The desired adjustments for the implant can be determined by monitoring the mitral valve during adjustment using echocardiography or other known diagnostic modalities. Once the desired adjustments are complete, the hex driver 1106 can be retracted into the adjustment tool 1135 and the attractive force between the magnetic docking element 1105 and the magnetic docking collar 1102 can be eliminated, such as by turning off the electromagnet that comprises the magnetic docking element 1105. Then, the adjustment tool 1135 can be removed from the interface location 1120 of the adjustment means 1130.

[00116] FIGS. 34-36 show another embodiment of the present invention in which the adjustment tool can be coupled to the adjustment means using a magnetic docking system. FIG. 34 is a lateral view of adjustment means 1230 that comprises gears 1203 inside a housing 1204. The adjustment means 1230 further comprises an internal hex 1201 that can drive the gears 1203, which in turn can adjust the size and/or shape of the implant. Specific details regarding the adjustment of the size and/or shape of the implant using the adjustment means 1230 are provided above, with respect to FIGS. 6-9. It is contemplated that the magnetic docking system of the present invention can be used with any of the methods or systems for adjusting the size and/or shape of the implant that were previously described herein or that are otherwise known in the art. Turning now to the magnetic docking aspect of the present invention, the adjustment means 1230 includes an interface location 1220 that enables the coupling of an adjustment tool. In the embodiment shown in FIG. 34, a magnetic docking collar 1202 is located along the surface of the housing 1204 adjacent the interface location 1220. The magnetic docking collar 1202 is preferably comprised of a ferromagnetic material, but any magnetic material that is consistent with the purpose of the present invention can be used. The function of the magnetic docking collar 1202 will be further described below.

[00117] FIG. 35 is an end view of the adjustment means 1230 shown in FIG. 34. As discussed above, the adjustment means 1230 comprises an internal hex 1201, a magnetic docking collar 1202, gears 1203 for adjusting the implant, and a housing 1204.

[00118] FIGS. 36a and 36b show an embodiment of an adjustment tool 1235 designed to couple with the interface location 1220 of the adjustment means 1230. A distal end of the adjustment tool 1235 comprises a magnetic docking element 1205 and a hex

driver 1206. As shown in FIGS. 36a and 36b, the magnetic docking element 1205 is located on a shaft of the adjustment tool 1235 adjacent to a distal tip of the adjustment tool 1235. The magnetic docking element 1205 preferably comprises an electromagnet, but can be any type of magnet that is consistent with the purpose of the present invention. In a particular embodiment of the present invention where the magnetic docking element 1205 comprises an electromagnet, the adjustment tool 1235 also preferably includes an electromagnetic winding 1210, as shown in FIGS. 36a and 36b. The magnetic docking element 1205 is used to aid in coupling or re-coupling the adjustment tool 1235 with the adjustment means 1230. More specifically, the magnetic docking element 1205 of the adjustment tool 1235 and the magnetic docking collar 1202 of the adjustment means 1230 are selected so that an attractive force will be generated when they are placed within a particular proximity of one another. The attractive force generated between the magnetic docking element 1205 and the magnetic docking collar 1202 will pull the distal end of the adjustment tool 1235 toward the adjustment means 1230 and guide it into the interface location 1220. For example, in a particular embodiment of the present invention where the magnetic docking element 1205 comprises an electromagnet, the adjustment tool 1235 is first manually guided to a location near the adjustment means 1230. Then, the electromagnet is turned on using a switch and an attractive force is generated between the electromagnet and the magnetic docking collar 1202 of the adjustment means 1230. This attractive force pulls the adjustment tool 1235 toward the adjustment means 1230 and guides it into the interface location 1220. Once coupled, the attractive force generated between the magnetic docking element 1205 and the magnetic docking collar 1202 will keep the adjustment tool 1235 and the adjustment means 1230 locked together.

[00119] The adjustment tool 1235 further comprises a hex driver 1206, as shown in FIGS. 36a and 36b. The hex driver 1206 is used to drive the internal hex 1201 of the adjustment means 1230, which in turn causes the gears 1203 to adjust the shape and/or size of the implant. The hex driver 1206 can be retracted within the adjustment tool 1235 while the tool is being inserted into the body (see FIG. 36b) and extended outward from the distal end of the adjustment tool 1235 when the tool is coupled with the adjustment means 1230 (see FIG. 36a). For example, after the adjustment tool 1235 has been coupled to the interface location 1220 using the magnetic docking system of the present invention, the hex driver 1206 can be extended until functionally connected to the internal hex 1201 and then rotated in order to actuate the gears 1203 and adjust the size and/or shape of the implant.

The extension or retraction of the hex driver 1206 is accomplished by pushing or pulling the hex driver handle 1211, respectively, which causes the hex driver shaft 1212 to move. In one embodiment of the present invention, extension of the hex driver 1206 is limited to the distance needed to actuate the gears 1203, using a limiting collar 1209. Once the adjustment tool 1235 is coupled to the adjustment means 1230 and the hex driver 1206 is extended into a functional connection with the internal hex 1201, the hex driver 1206 may be operated by holding the adjustment tool handle 1208 (which may be rough for increased grip) and rotating the hex driver tool handle 1211 (which may also have a rough surface for better control and grip). Rotation of the hex driver handle 1211 will cause the internal hex 1201 to drive the gears 1203, which, in turn, causes adjustment of the shape and/or size of the implant. As discussed above with respect to FIGS. 6-9, the direction of rotation will determine whether the implant increases or decreases in size. The desired adjustments for the implant can be determined by monitoring the mitral valve during adjustment using echocardiography or other known diagnostic modalities. Once the desired adjustments are complete, the hex driver 1206 can be retracted into the adjustment tool 1235 and the attractive force between the magnetic docking element 1205 and the magnetic docking collar 1202 can be eliminated, such as by turning off the electromagnet that comprises the magnetic docking element 1205. Then, the adjustment tool 1235 can be removed from the interface location 1220 of the adjustment means 1230.

[00120] In another embodiment of the magnetic docking system, the magnetic docking collar and the magnetic docking element enable the adjustment tool and the adjustment means to be functionally coupled to one another without a direct, physical engagement.

[00121] FIG. 37 shows an adjustment tool 1335 with a magnetic docking element 1305 entering the right atrium of the heart via the superior vena cava. In this embodiment, the magnetic docking element 1305 is an electromagnet, which is controlled by switch 1350. When the switch 1350 is open, as in FIG. 37, the electromagnet is off. It is contemplated that the adjustment tool can be inserted into the right atrium using any known methods, including percutaneous methods.

[00122] FIG. 38 shows the adjustment tool 1335 crossing into the left atrium where the mitral valve 1340 is located. An implant 1345 is attached to the mitral valve 1340 and includes an adjustment means 1330 with a magnetic docking collar (not shown), as

previously described above. It is contemplated that the adjustment tool can be inserted into the left atrium using any known methods, including percutaneous methods.

[00123] FIGS. 39 and 40 show the magnetic docking system when the switch 1350 that controls the magnetic docking element 1305 is closed. An attractive force is generated between the magnetic docking element 1305 and the magnetic docking collar (not shown) of the adjustment means 1330. The adjustment tool 1335 is pulled toward the adjustment means 1330 until the two become coupled together. Once coupled, the attractive force generated between the magnetic docking element 1305 and the magnetic docking collar (not shown) of the adjustment means 1330 will keep the adjustment tool 1335 and the adjustment means 1330 locked together. The adjustment tool 1335 can then be used to make the desired adjustments to the implant 1345 and the mitral valve 1340, as described above.

[00124] Once the desired adjustments are complete, the switch 1350 can be opened as shown in FIGS. 41 and 42. This will turn the electromagnet off, and eliminate the attractive force between the magnetic docking element 1305 and the magnetic docking collar (not shown). The adjustment tool 1335 can then be removed from the body using known techniques.

[00125] It is understood that the adjustment tool 1335 can be inserted into the body and delivered to an area near the adjustment means 1330 using any known methods or techniques, including for example delivering the adjustment tool 1335 via the right jugular vein or the right femoral vein.

[00126] Finally, it will be understood that the preferred embodiment has been disclosed by way of example, and that other modifications may occur to those skilled in the art without departing from the scope and spirit of the appended claims.

CLAIMS

1. A device for adjusting at least one of the shape and size of an anatomic orifice or lumen, comprising:
 - an adjustable implant body configured to adjust at least one of the shape and size of an anatomic orifice or lumen; and
 - an adjustment tool configured to be removably coupled to an adjustable member of the adjustable implant body such that the adjustment tool can be used to activate adjustment of at least one of the shape and size of the anatomic orifice or lumen, wherein the adjustment tool comprises a magnet that can be used to couple the adjustment tool to the adjustable member.
2. The device of claim 1, wherein the magnet is an electromagnet.
3. The device of claim 1, wherein the adjustable member comprises a magnetic material that can be used to couple the adjustment tool to the adjustable member.
4. The device of claim 3, wherein the magnetic material is a ferromagnetic material.
5. The device of claim 3, wherein an attractive force is generated between the magnet and the magnetic material when the adjustable member and the adjustment tool are in close proximity to one another.
6. The device of claim 5, wherein the attractive force guides the adjustment tool into an interface location of the adjustable member.
7. The device of claim 1, wherein the adjustable tool comprises a hex driver that can be withdrawn into a shaft of the adjustment tool before the adjustment tool is coupled with the adjustable member and extended out from the shaft after the adjustment tool is coupled with the adjustable member.
8. The device of claim 1, wherein the adjustment tool comprises a distal end and a proximal end, the distal end being removably coupled to the adjustable member and a

shaft of the adjustment tool extending therefrom such that adjustments to the anatomic orifice or lumen can be made remotely using the proximal end of the adjustment tool.

9. The device of claim 1, wherein the adjustment tool can be coupled to the adjustable member of the adjustable implant body using a minimally invasive procedure.

10. The device of claim 1, wherein the adjustment tool and the adjustment member are functionally coupled to one another without any direct physical engagement such that the adjustment tool can be used to activate adjustment of at least one of the shape and size of the anatomic orifice or lumen.

11. A method for adjusting at least one of the shape and size of an anatomic orifice or lumen, comprising the steps of:

attaching an adjustable implant body to tissue adjacent to the anatomic orifice or lumen;

coupling an adjustment tool to an adjustable member of the adjustable implant body, wherein the adjustment tool comprises a magnet that can be used to couple the adjustment tool to the adjustable member; and

using the adjustment tool to adjust at least one of the shape and size of the anatomic orifice or lumen.

12. The method of claim 11, wherein the magnet is an electromagnet.

13. The method of claim 12, wherein the electromagnet is turned on when the adjustment tool is in close proximity to the adjustable member.

14. The method of claim 11, wherein the adjustable member comprises a magnetic material that can be used to couple the adjustment tool to the adjustable member.

15. The method of claim 14, wherein an attractive force is generated between the magnet and the magnetic material when the adjustable member and the adjustment tool are in close proximity to one another.

16. The method of claim 15, wherein the attractive force guides the adjustment tool into an interface location of the adjustable member.
17. The method of claim 11, wherein the adjustable tool comprises a hex driver that can be withdrawn into a shaft of the adjustment tool before the adjustment tool is coupled with the adjustable member and extended out from the shaft after the adjustment tool is coupled with the adjustable member.
18. The method of claim 11, wherein the adjustment tool comprises a distal end and a proximal end, the distal end being removably coupled to the adjustable member and a shaft of the adjustment tool extending therefrom such that adjustments to the anatomic orifice or lumen can be made remotely using the proximal end of the adjustment tool.
19. The method of claim 11, wherein the adjustment tool can be coupled to the adjustable member of the adjustable implant body using a minimally invasive procedure.
20. The method of claim 11, wherein the step of using the adjustment tool to adjust at least one of the shape and size of the anatomic orifice or lumen is performed after normal flow of blood through the anatomic orifice or lumen has resumed.

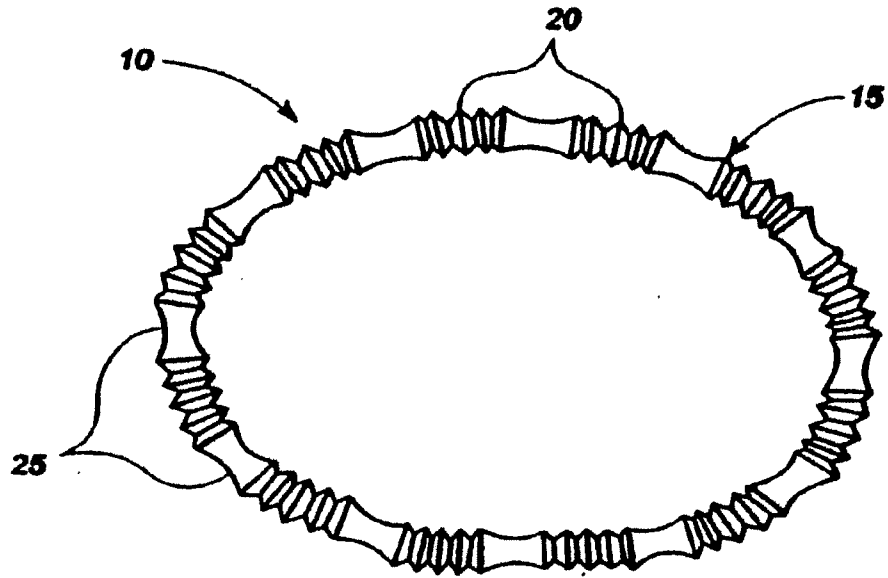

Fig. 1

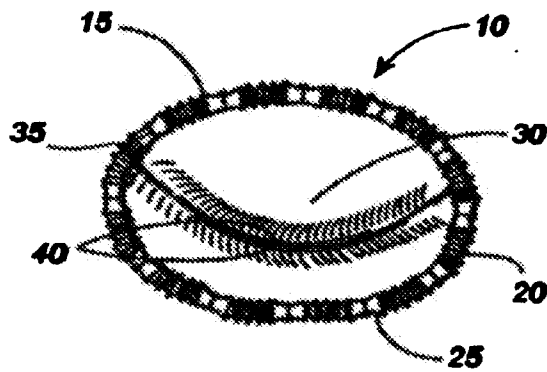

Fig. 2

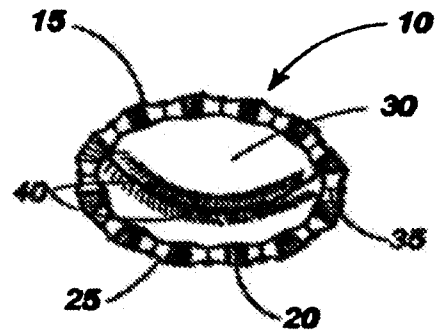
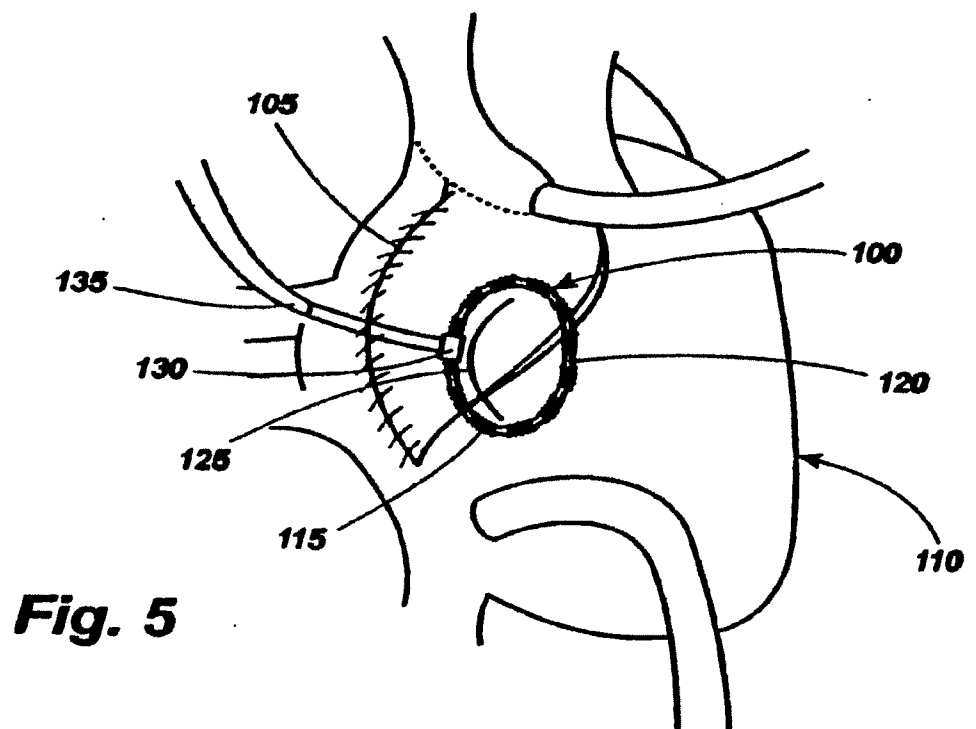
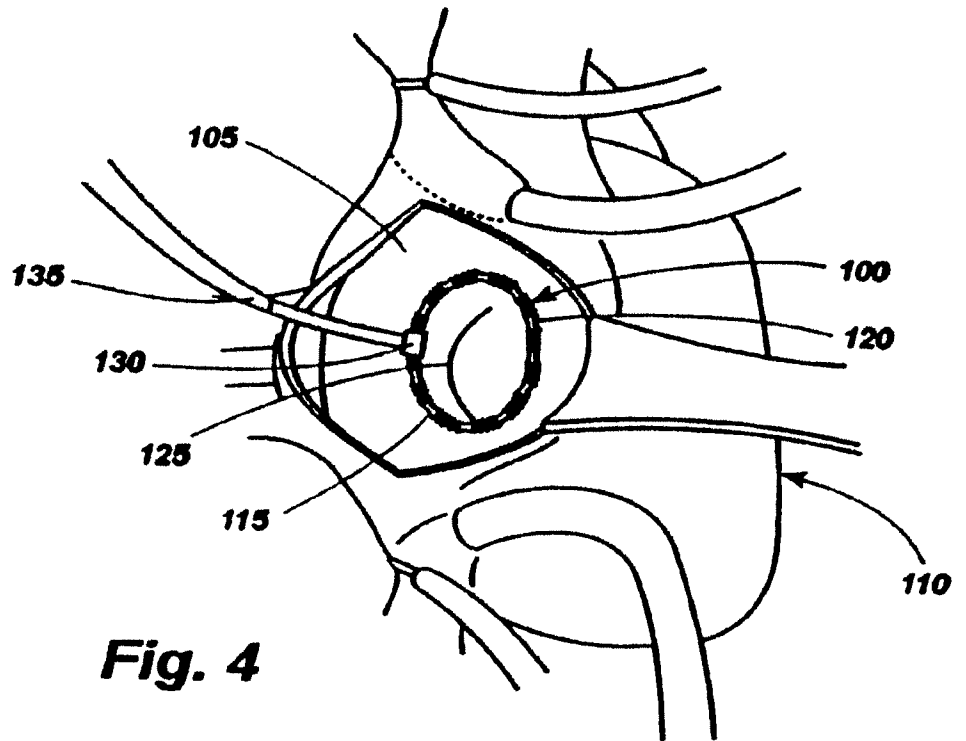
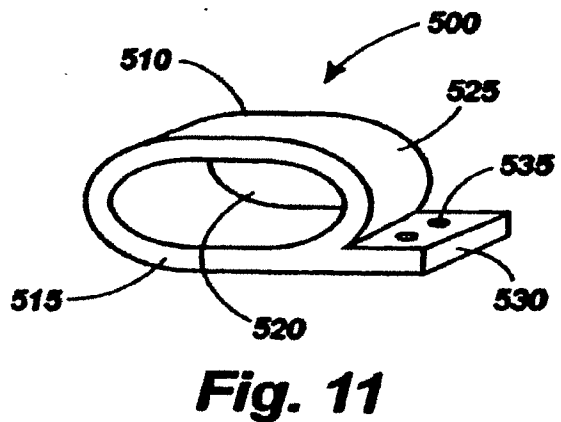
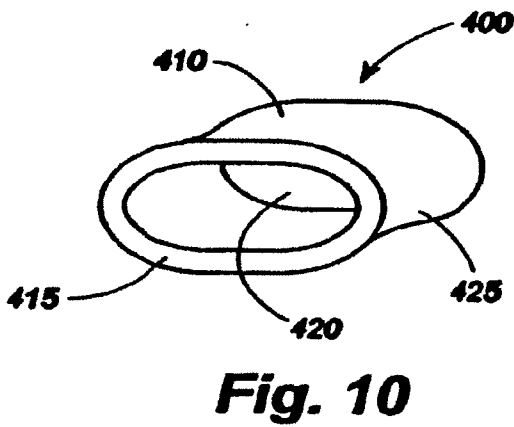
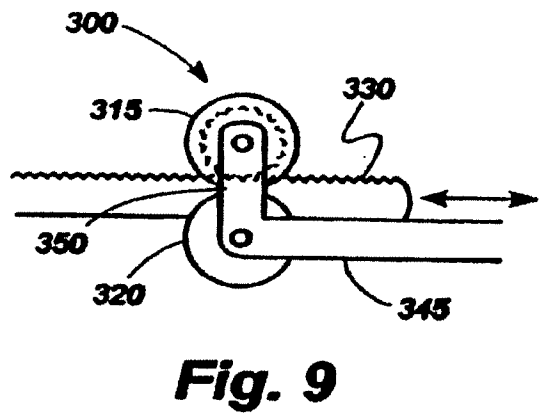
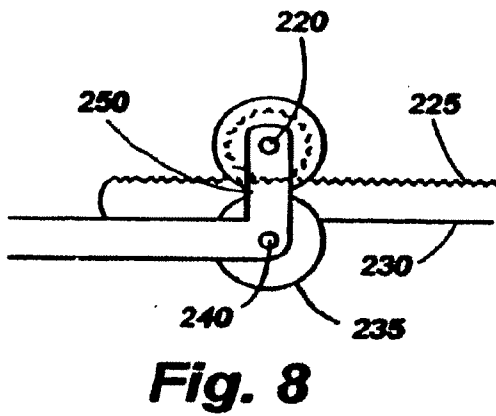
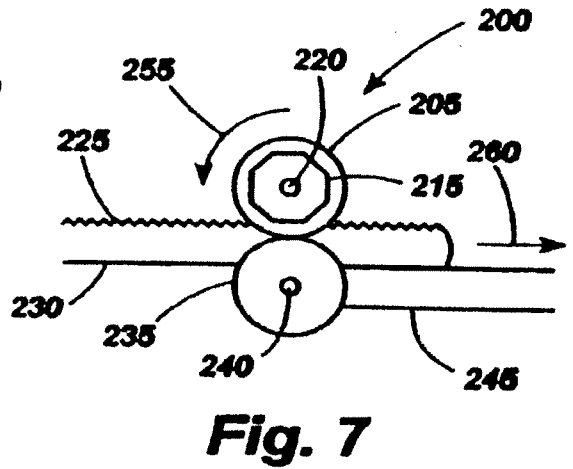
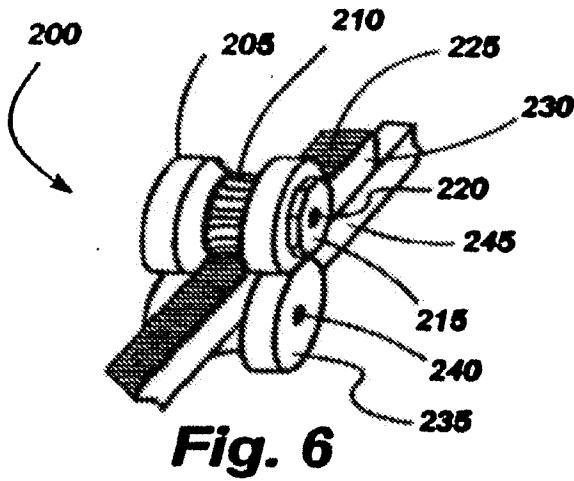

Fig. 3





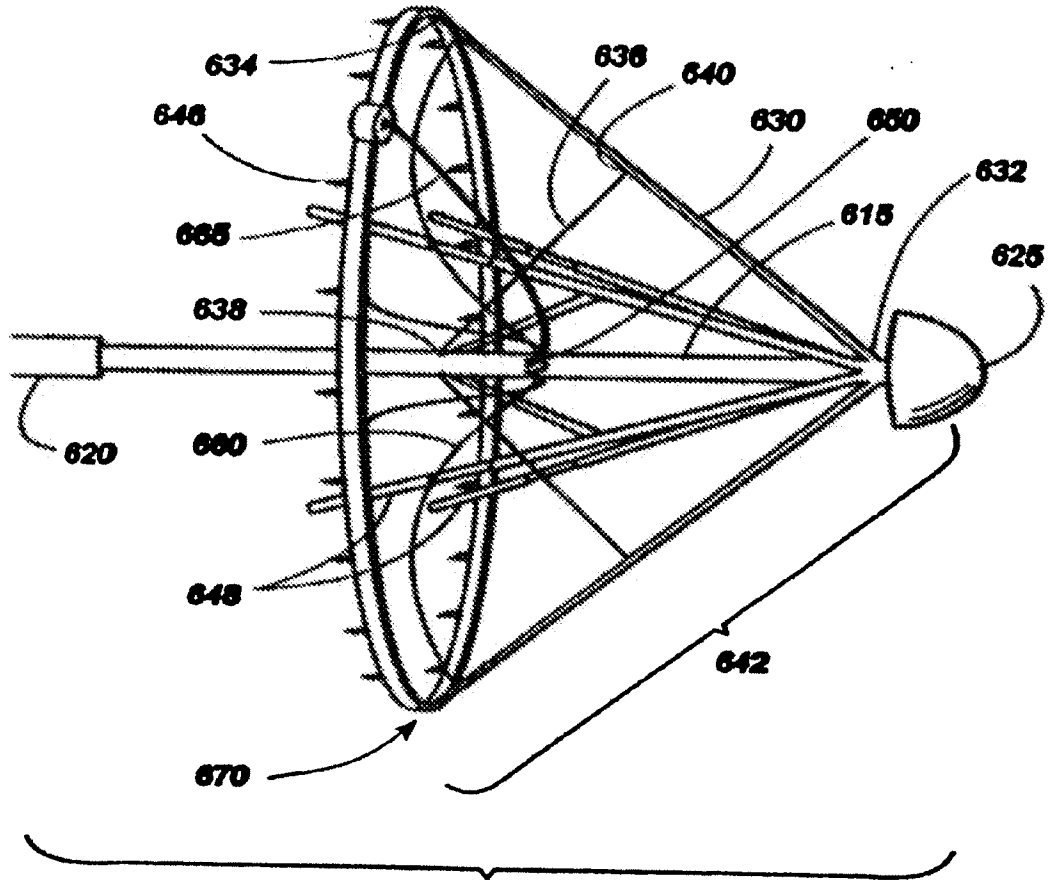

Fig. 12

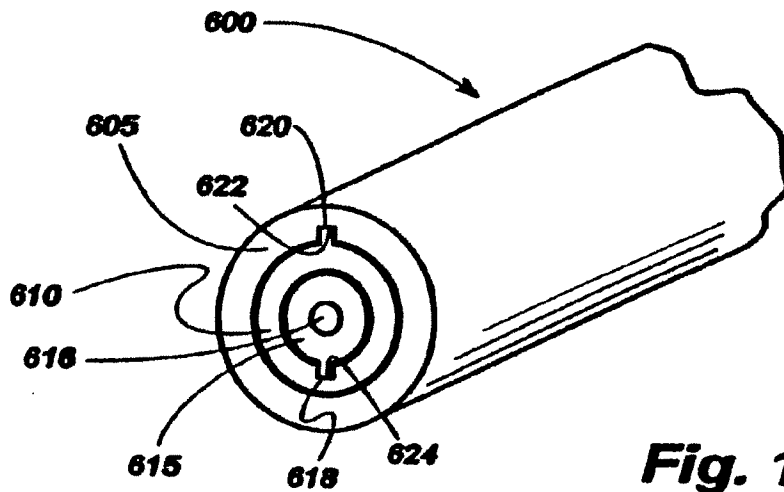
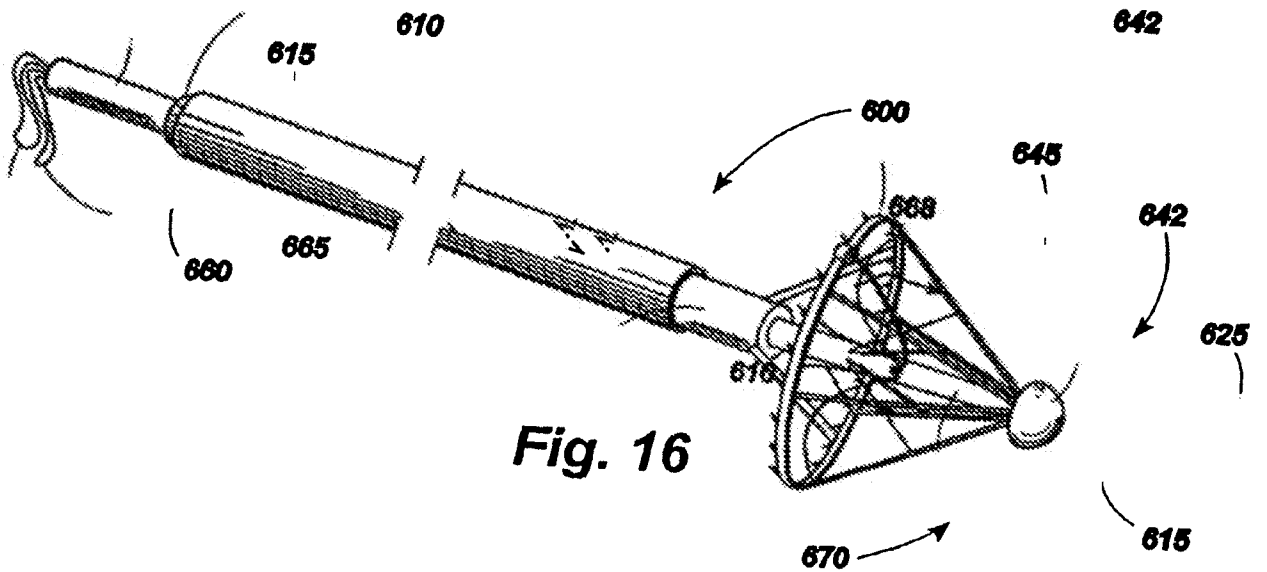
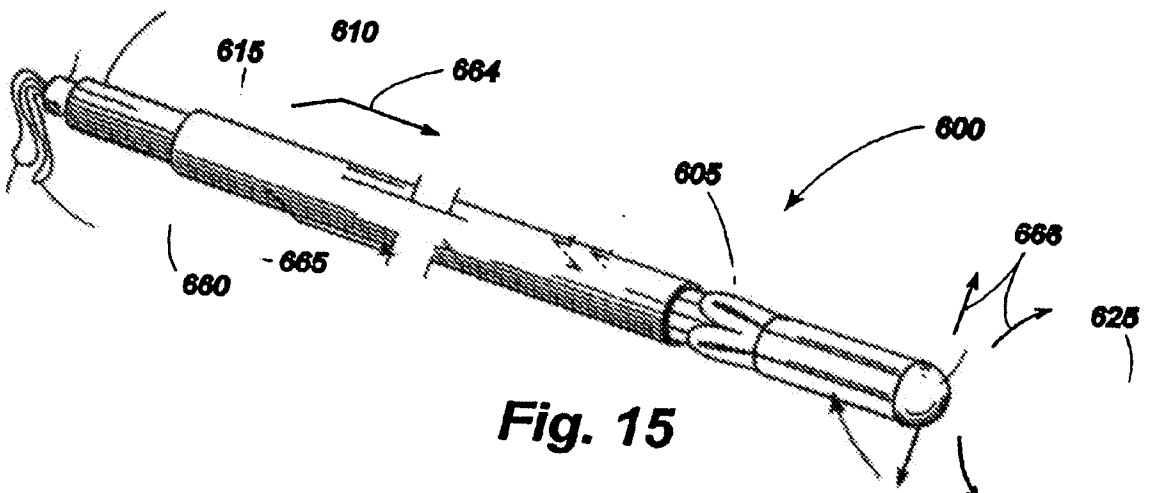
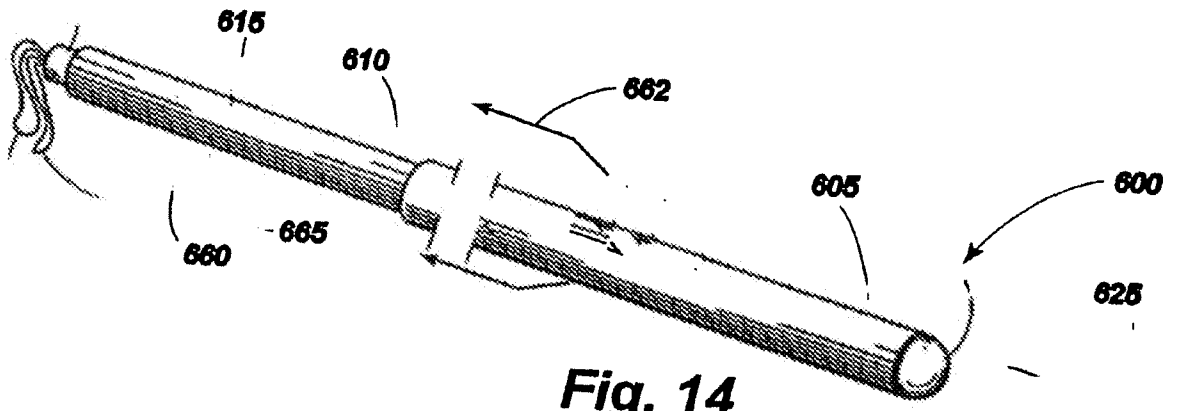

Fig. 13



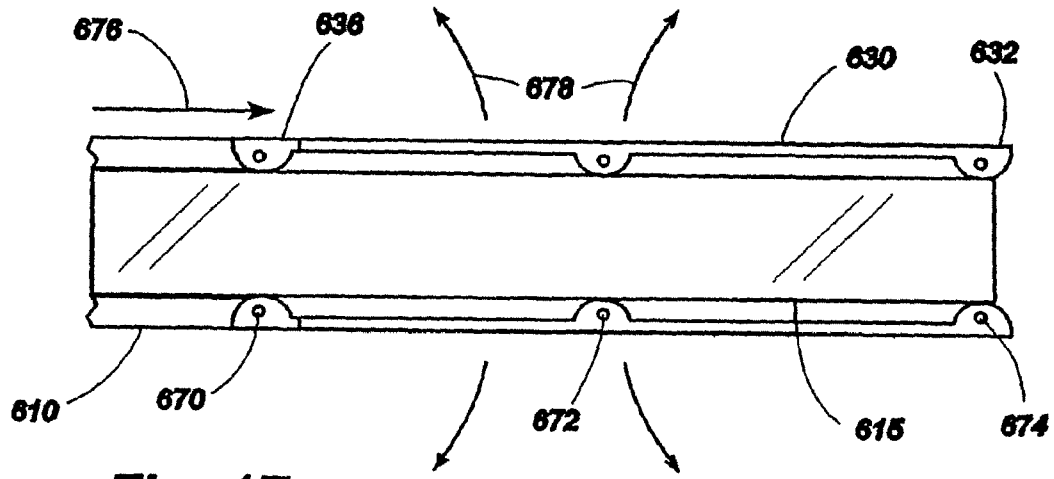

Fig. 17

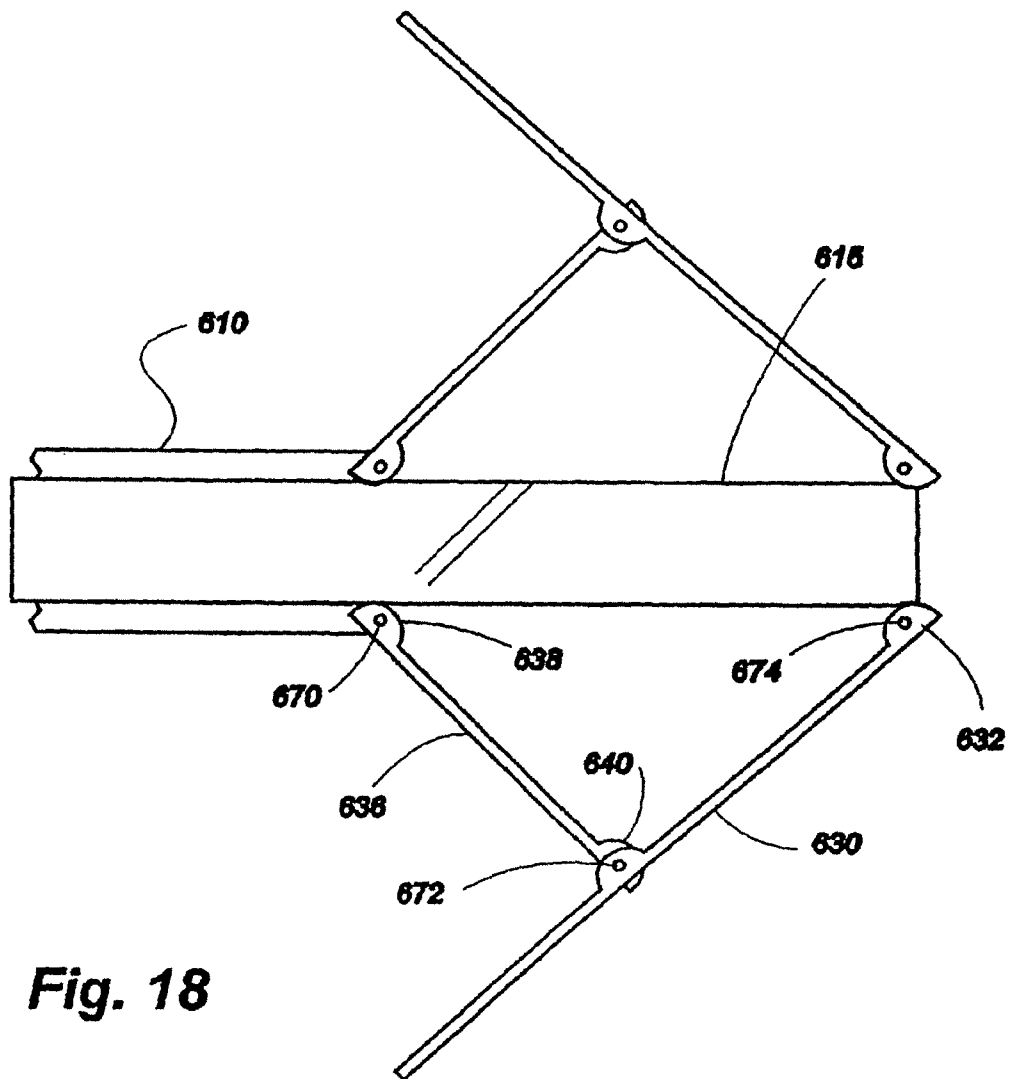
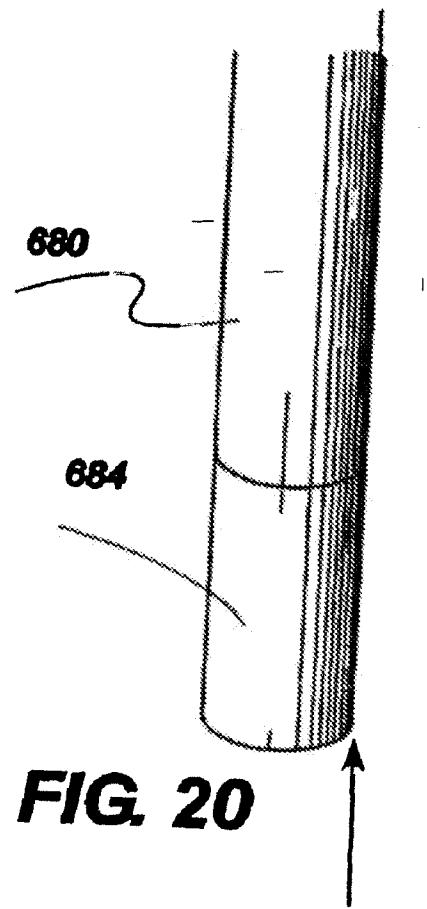
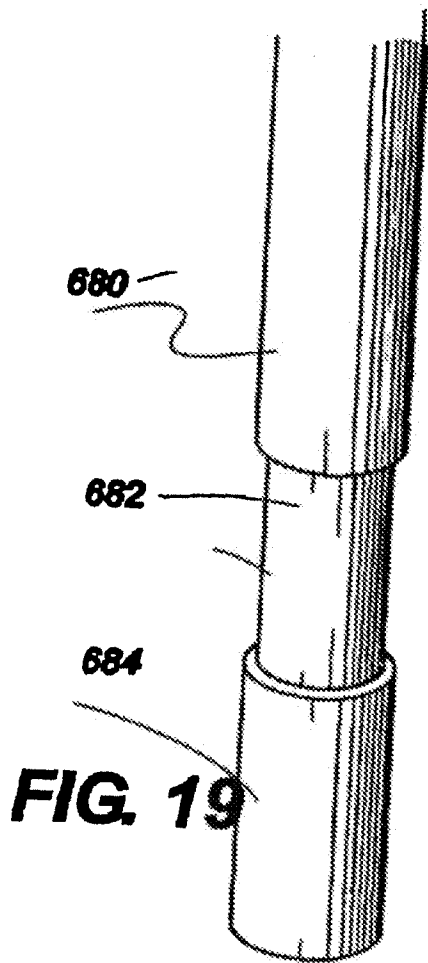
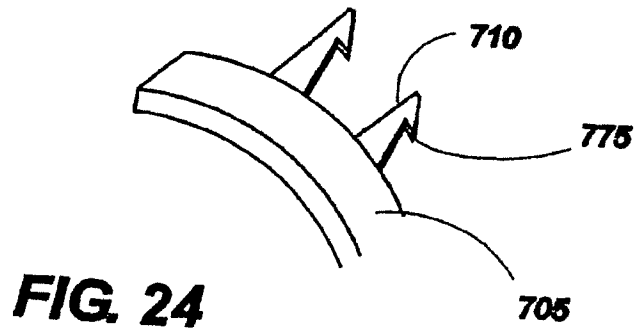
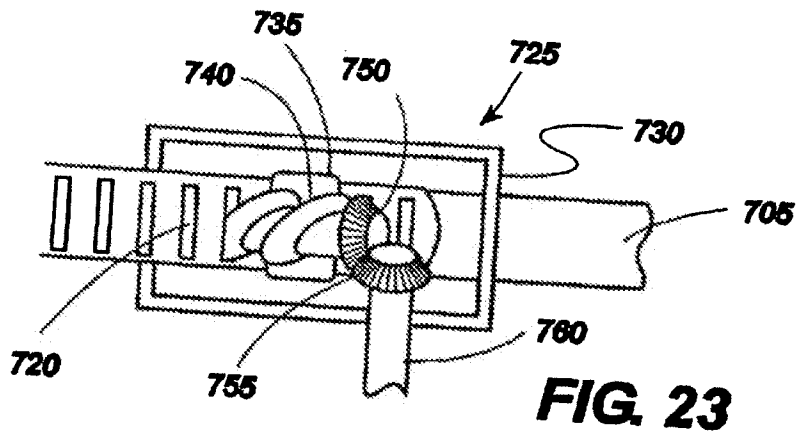
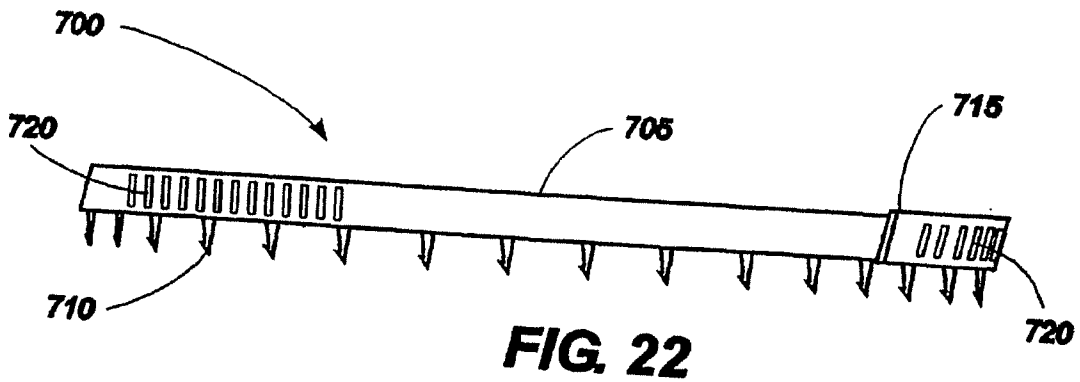
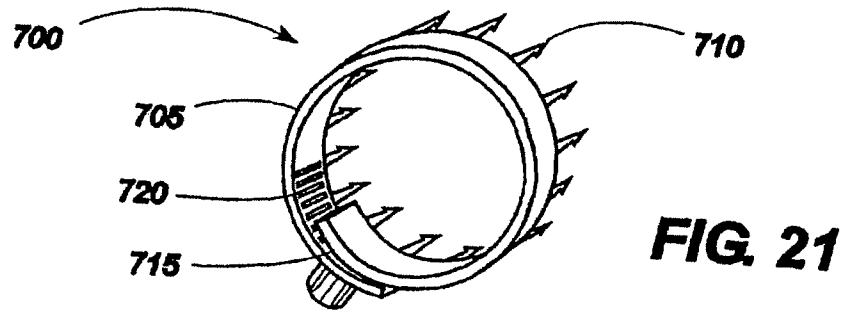

Fig. 18





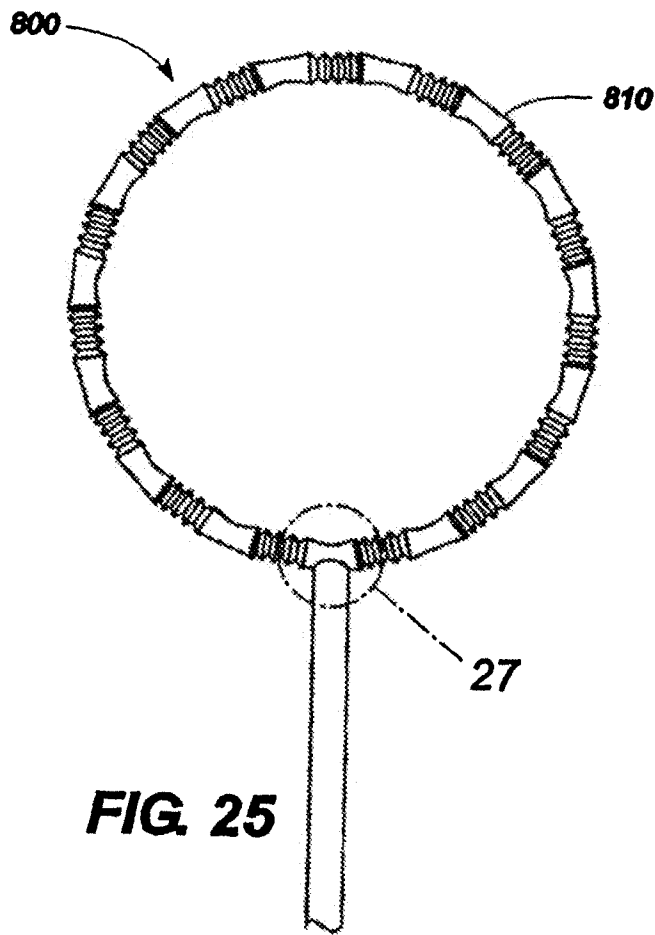

FIG. 25

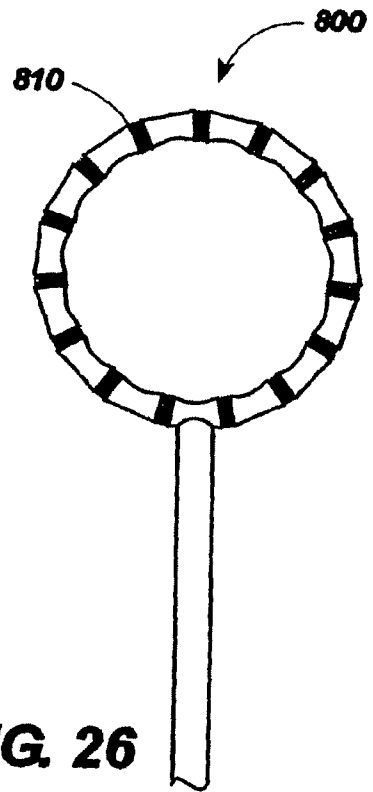

FIG. 26

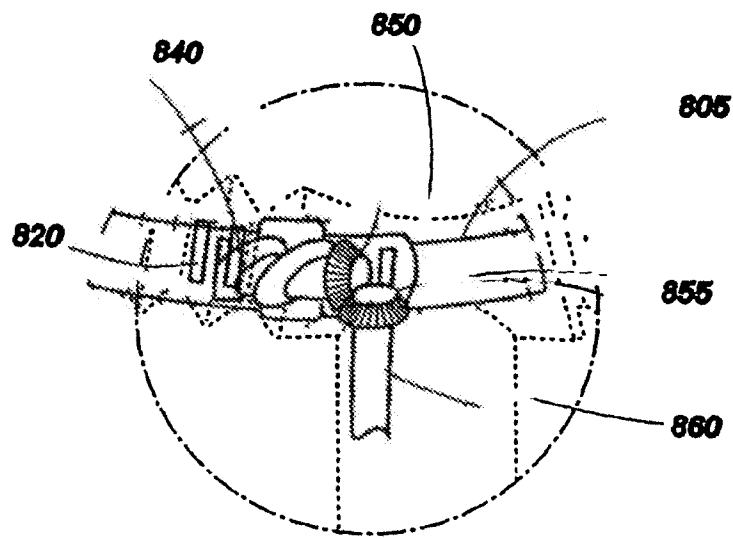

FIG. 27

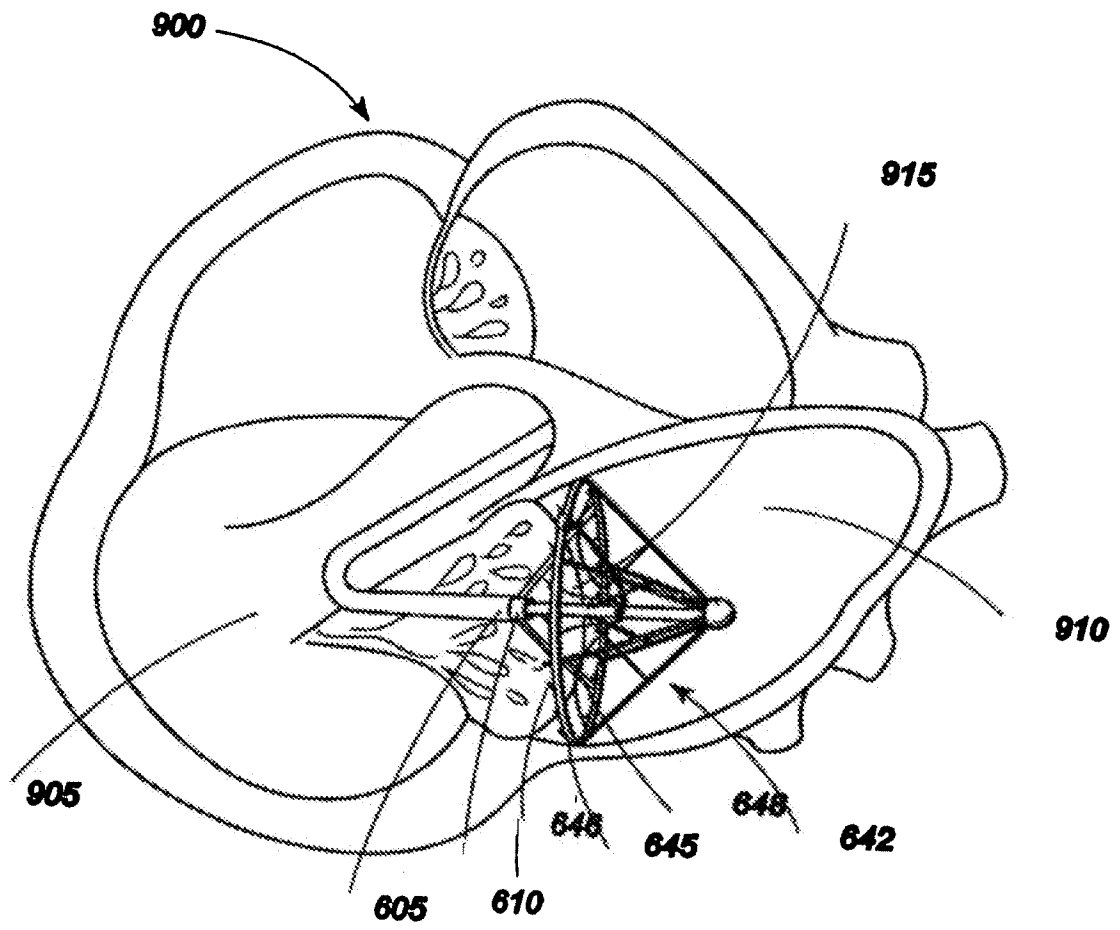

FIG. 28

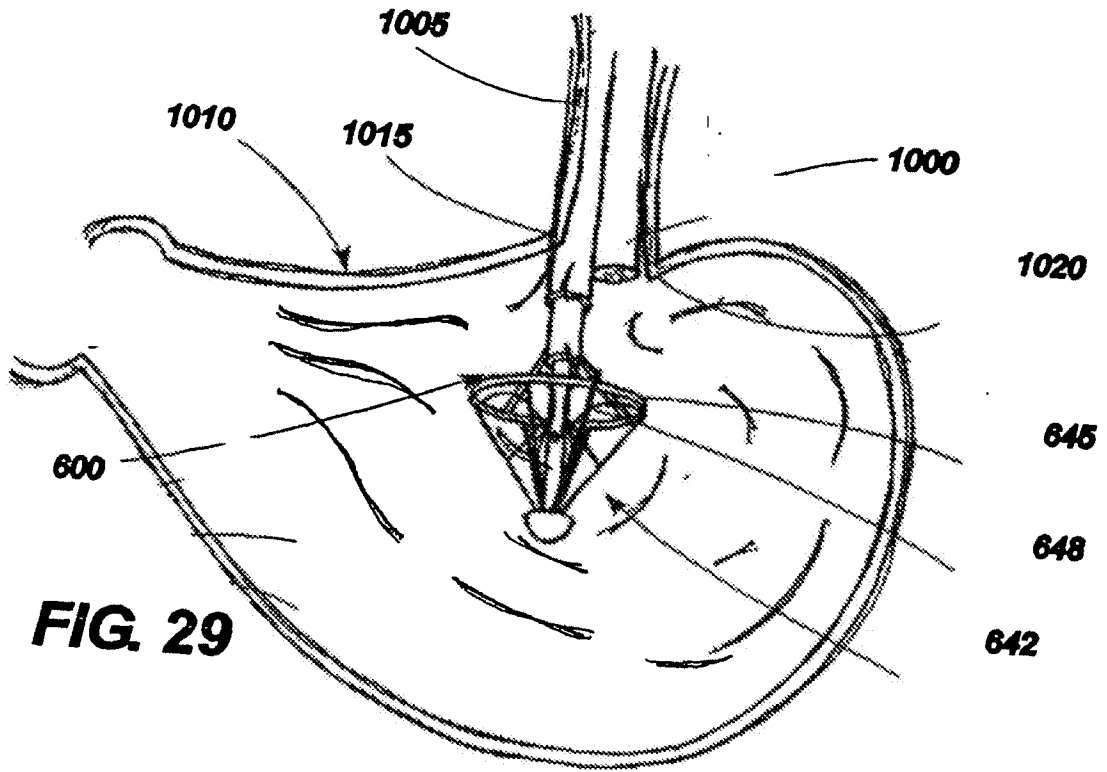

FIG. 29

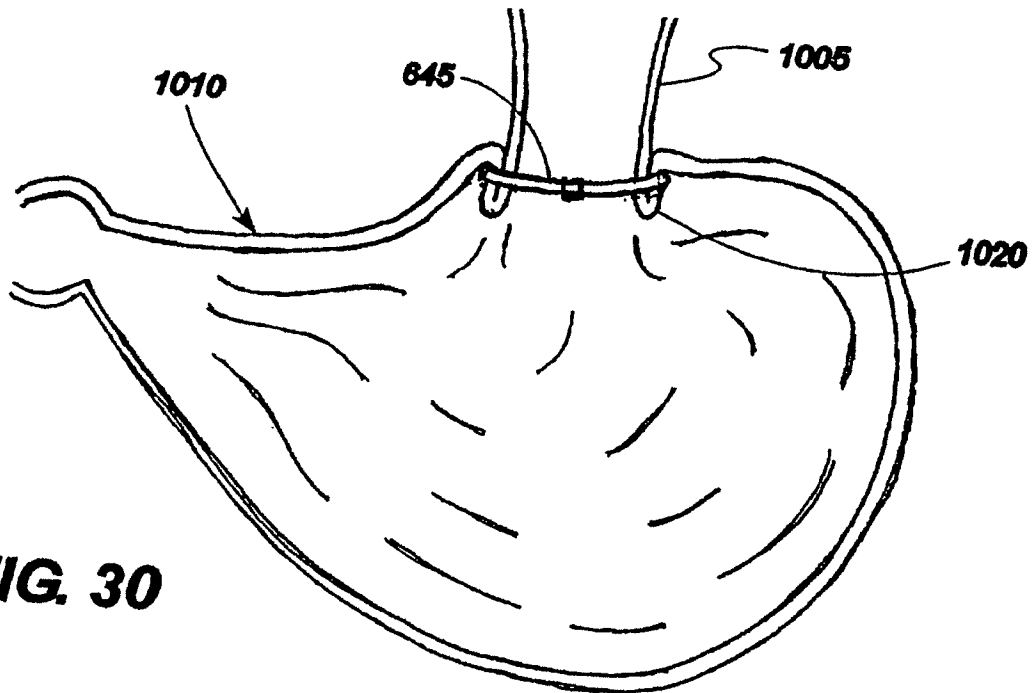

FIG. 30

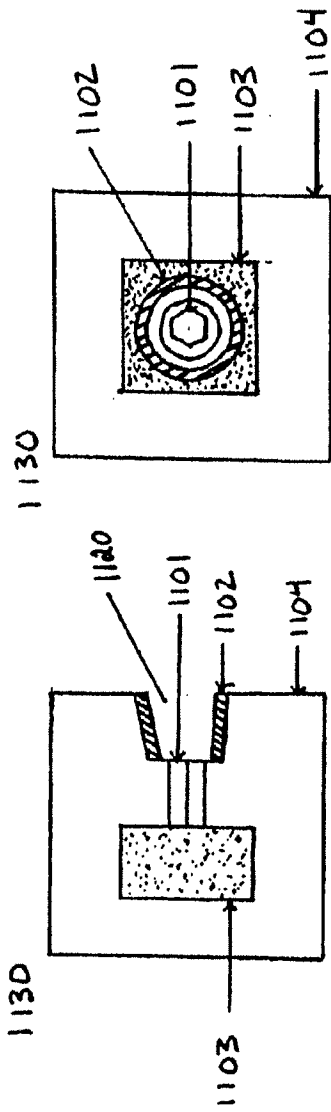

Fig. 32

Fig. 31

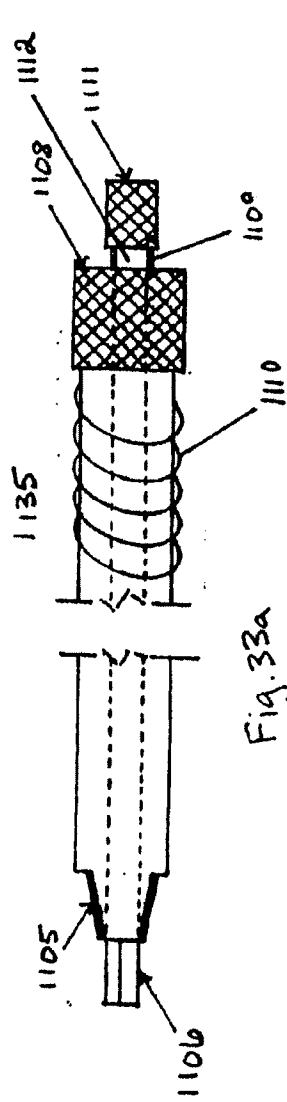

Fig. 33a

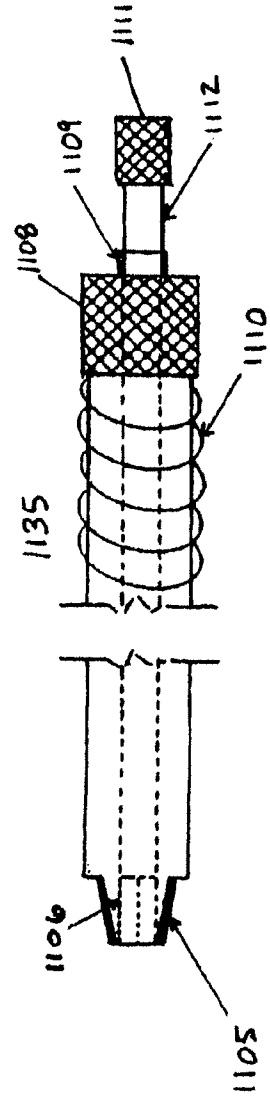

Fig. 33b

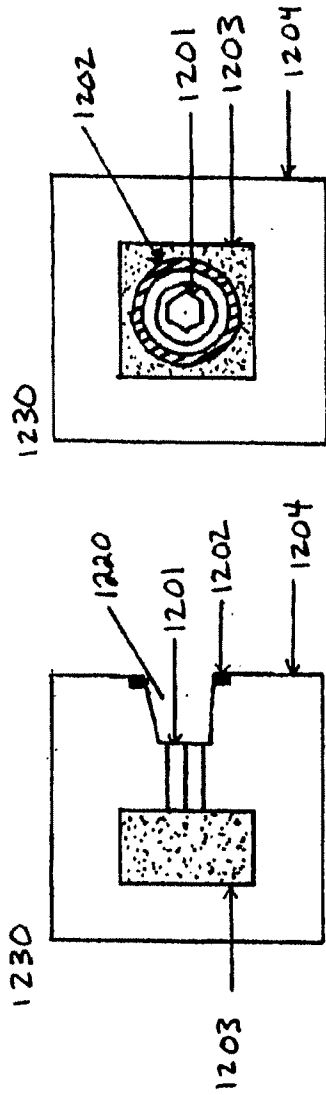

Fig. 35

Fig. 34

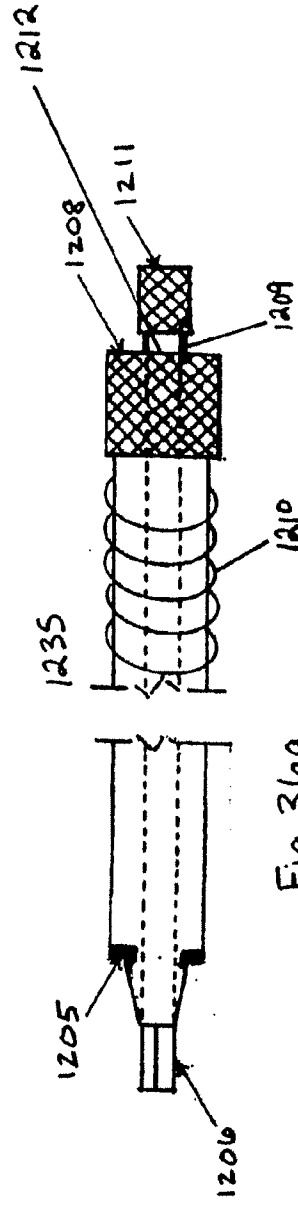

Fig. 36a

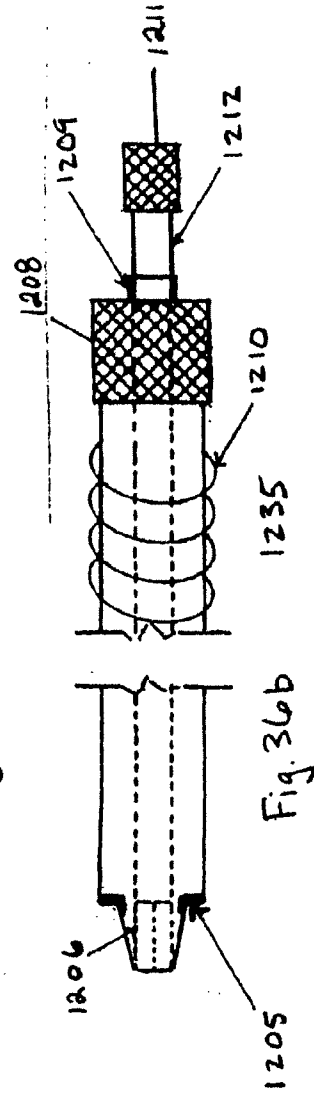

Fig. 36b

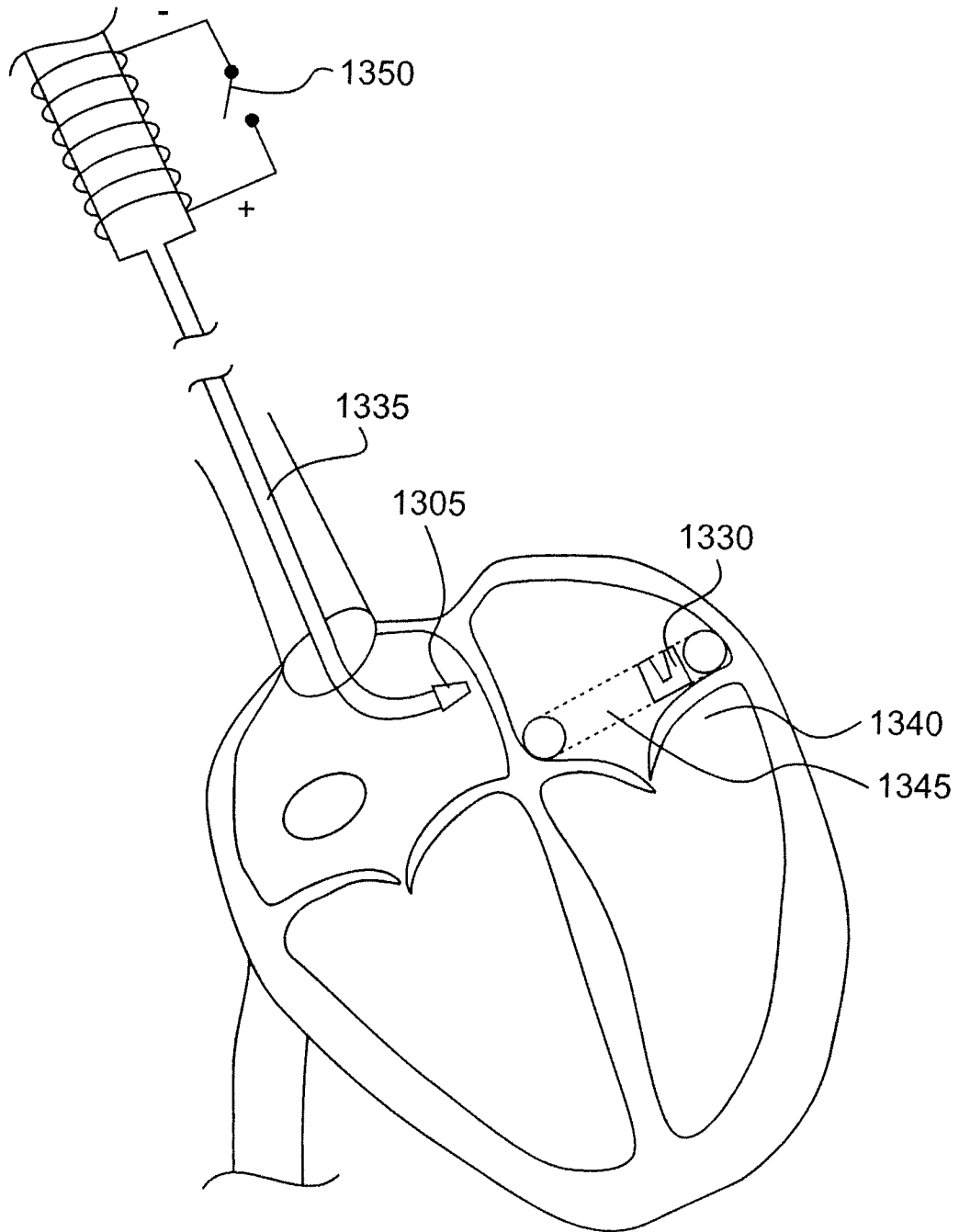

FIG. 37

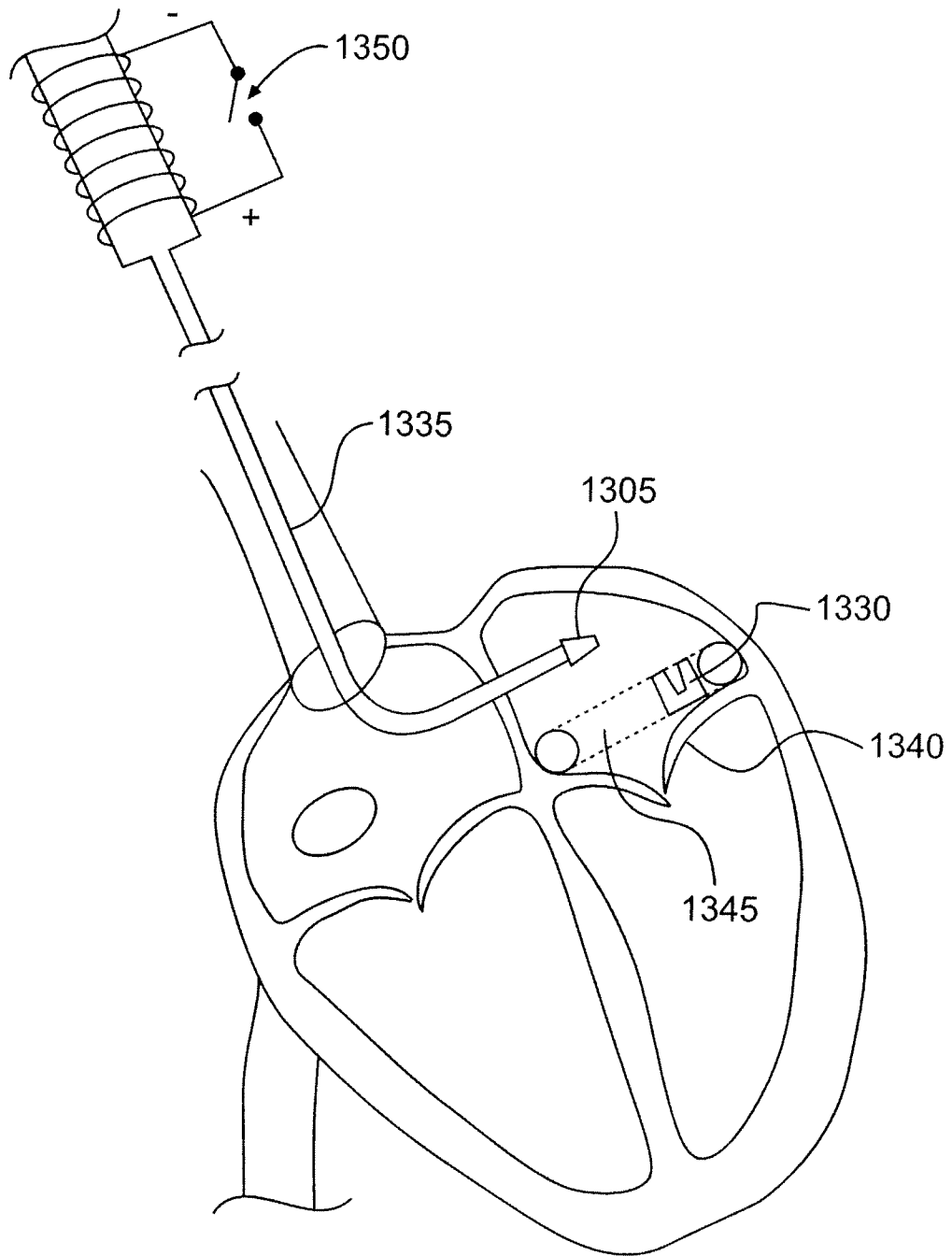

FIG. 38

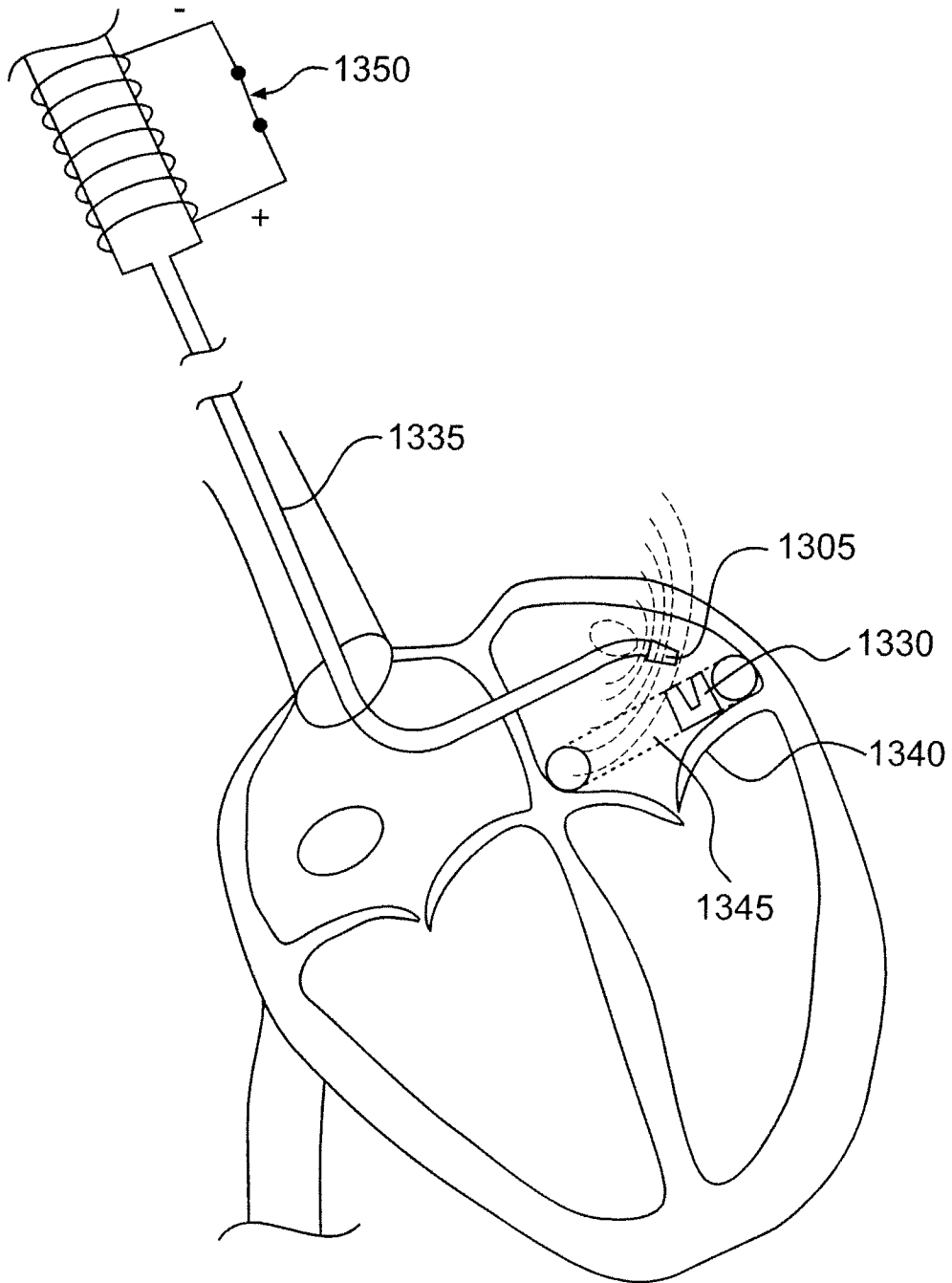

FIG. 39

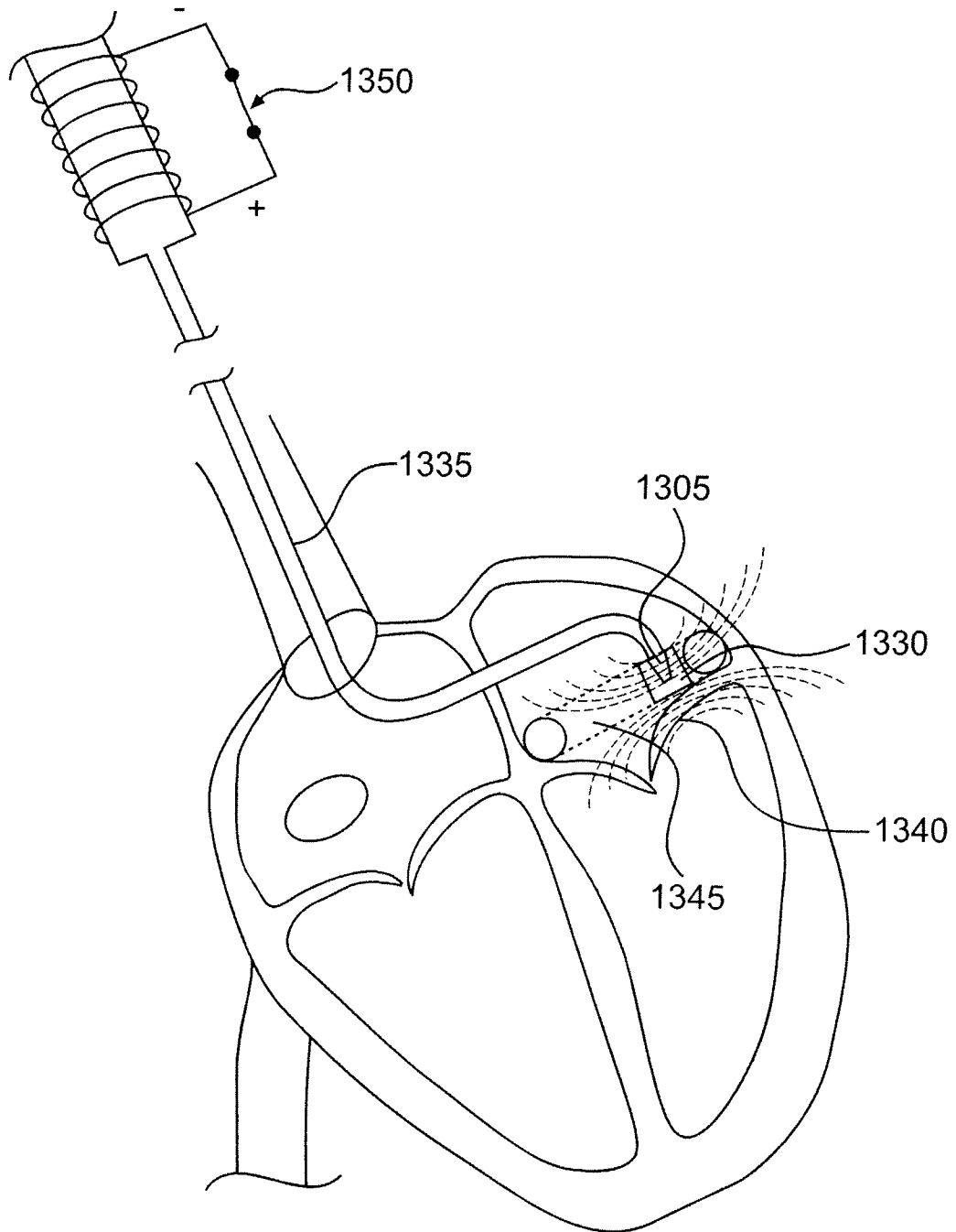

FIG. 40

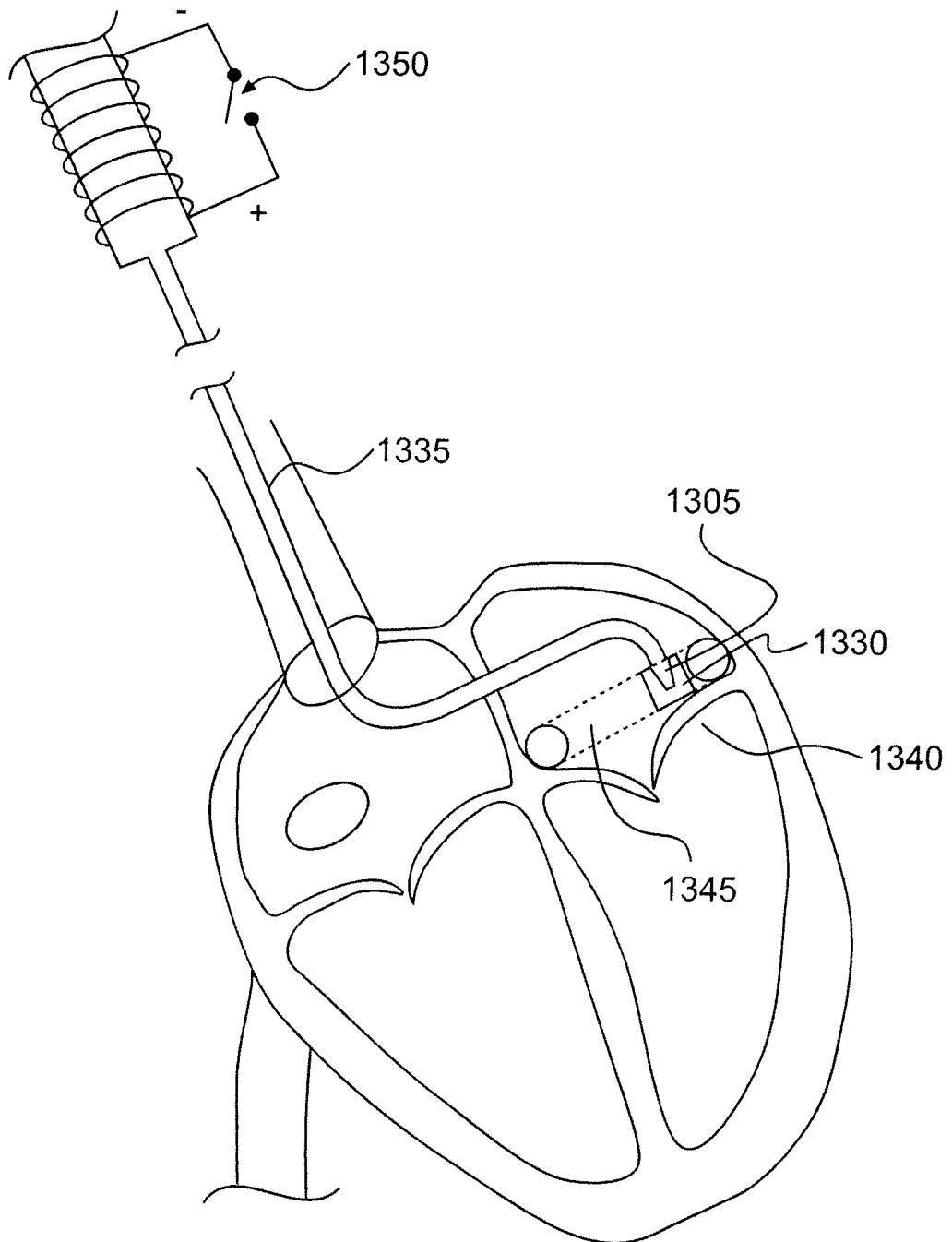

FIG. 41

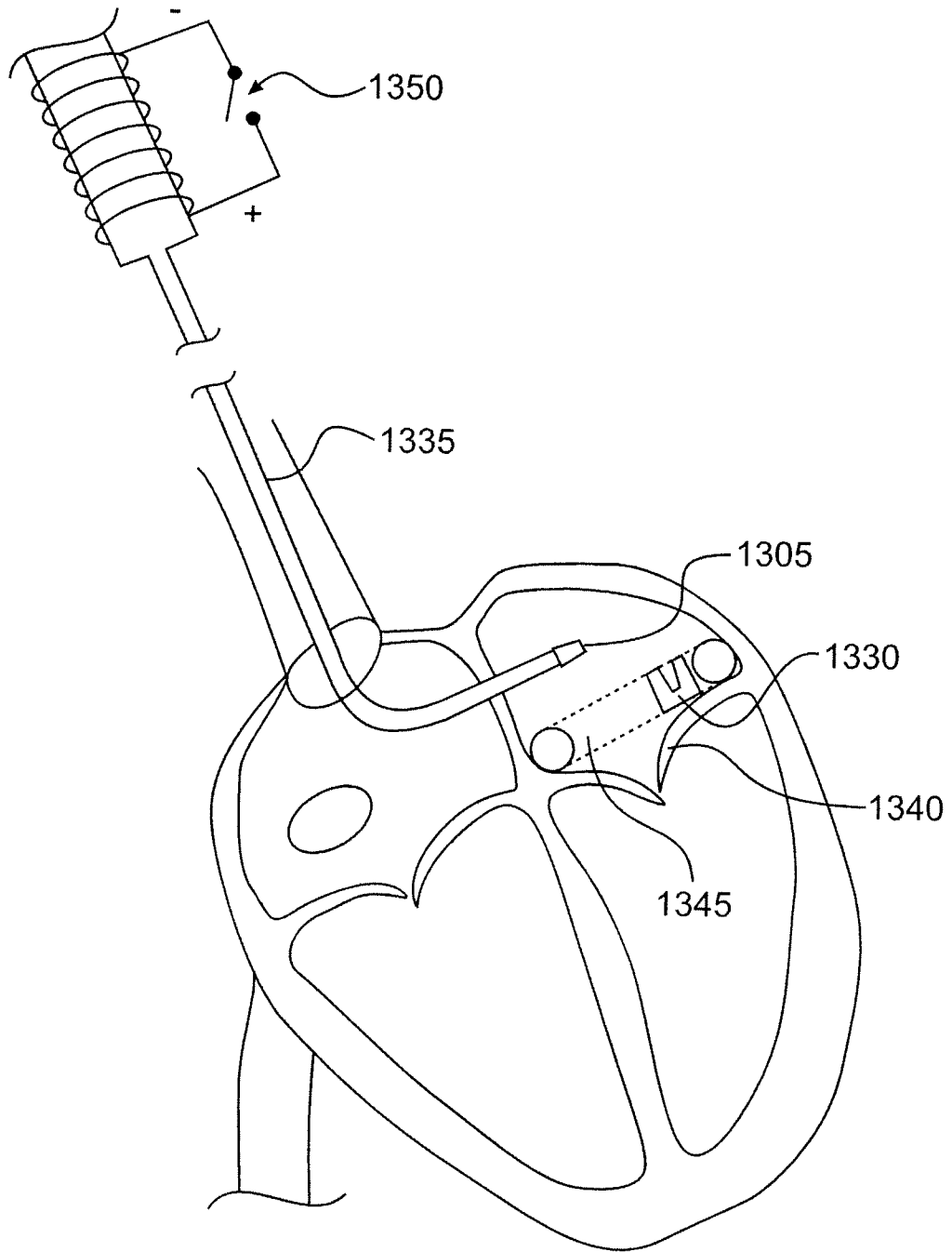

FIG. 42

INTERNATIONAL SEARCH REPORT

International application No.

PCT/US2010/021822

A. CLASSIFICATION OF SUBJECT MATTER IPC(8) - A61F 2/24 (2010.01) USPC - 623/2.37 According to International Patent Classification (IPC) or to both national classification and IPC		
B. FIELDS SEARCHED Minimum documentation searched (classification system followed by classification symbols) IPC(8) -A61F 2/24 (2010.01) USPC - 623/2.37, 3.11 Documentation searched other than minimum documentation to the extent that such documents are included in the fields searched Electronic data base consulted during the international search (name of data base and, where practicable, search terms used) PatBase		
C. DOCUMENTS CONSIDERED TO BE RELEVANT		
Category*	Citation of document, with indication, where appropriate, of the relevant passages	Relevant to claim No.
Y	US 2004/0148021 A1 (CARTLEDGE et al) 29 July 2004 (29.07.2004) entire document	1-20
Y	US 2004/0011365 A1 (GOVARI et al) 22 January 2004 (22.01.2004) entire document	1-20
Y	US 2007/0016287 A1 (CARTLEDGE et al) 18 January 2007 (18.01.2007) entire document	7, 17, 20
<input type="checkbox"/> Further documents are listed in the continuation of Box C. <input type="checkbox"/>		
* Special categories of cited documents: "A" document defining the general state of the art which is not considered to be of particular relevance "E" earlier application or patent but published on or after the international filing date "L" document which may throw doubts on priority claim(s) or which is cited to establish the publication date of another citation or other special reason (as specified) "O" document referring to an oral disclosure, use, exhibition or other means "P" document published prior to the international filing date but later than the priority date claimed "T" later document published after the international filing date or priority date and not in conflict with the application but cited to understand the principle or theory underlying the invention "X" document of particular relevance; the claimed invention cannot be considered novel or cannot be considered to involve an inventive step when the document is taken alone "Y" document of particular relevance; the claimed invention cannot be considered to involve an inventive step when the document is combined with one or more other such documents, such combination being obvious to a person skilled in the art "&" document member of the same patent family		
Date of the actual completion of the international search 06 March 2010		Date of mailing of the international search report 17 MAR 2010
Name and mailing address of the ISA/US Mail Stop PCT, Attn: ISA/US, Commissioner for Patents P.O. Box 1450, Alexandria, Virginia 22313-1450 Facsimile No. 571-273-3201		Authorized officer: Blaine R. Copenheaver PCT Helpdesk: 571-272-4300 PCT OSP: 571-272-7774