

I. UNGER.
TOBACCO TRANSPLANTER.

No. 523,800.

Patented July 31, 1894.

Fig. 1.

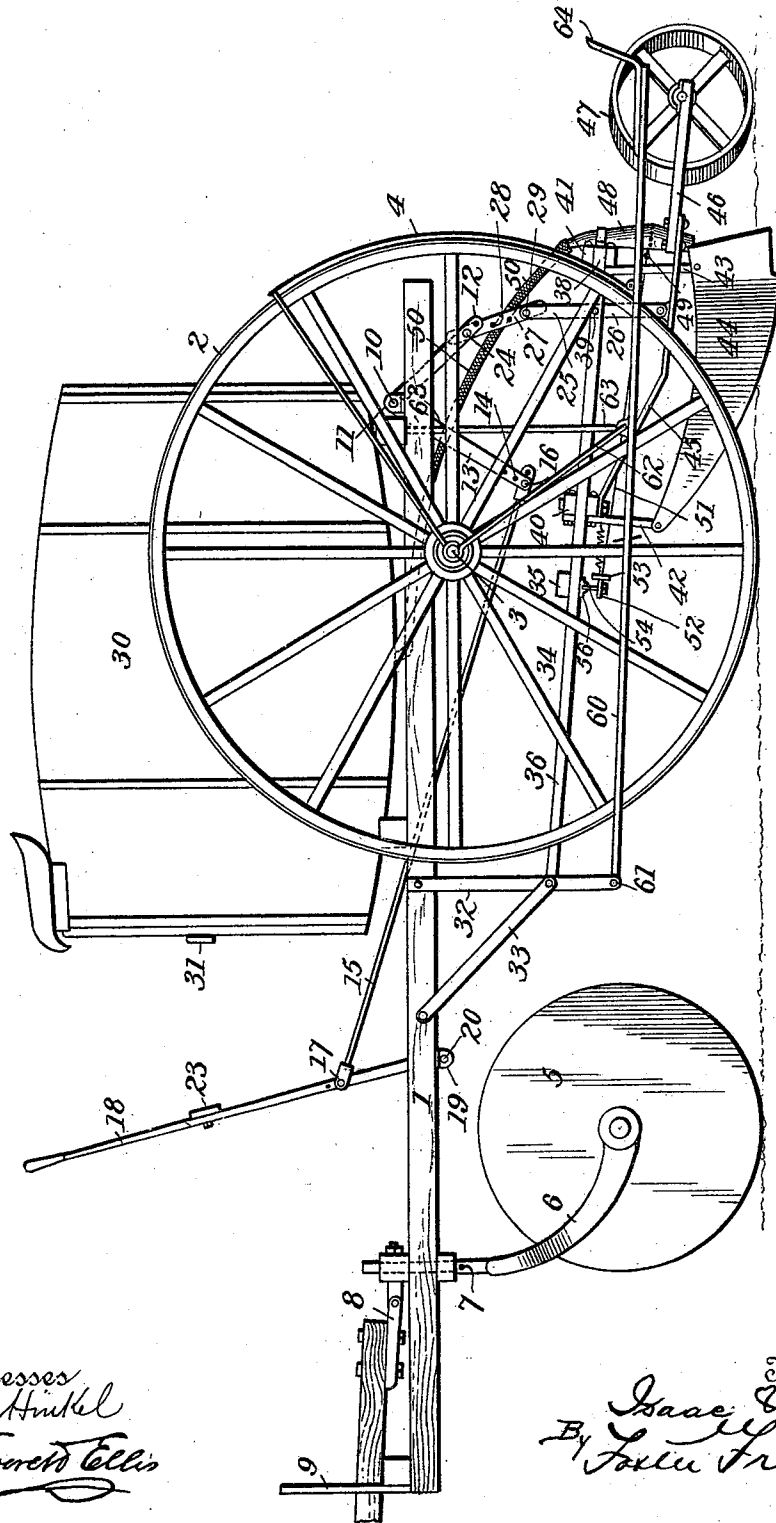

Witnesses
J. G. Hinkel
E. Everett Ellis

Inventor
Isaac Unger
 By *John Freeman*
 Attorneys

I. UNGER.
TOBACCO TRANSPLANTER.

No. 523,800.

Patented July 31, 1894.

Fig. 2.

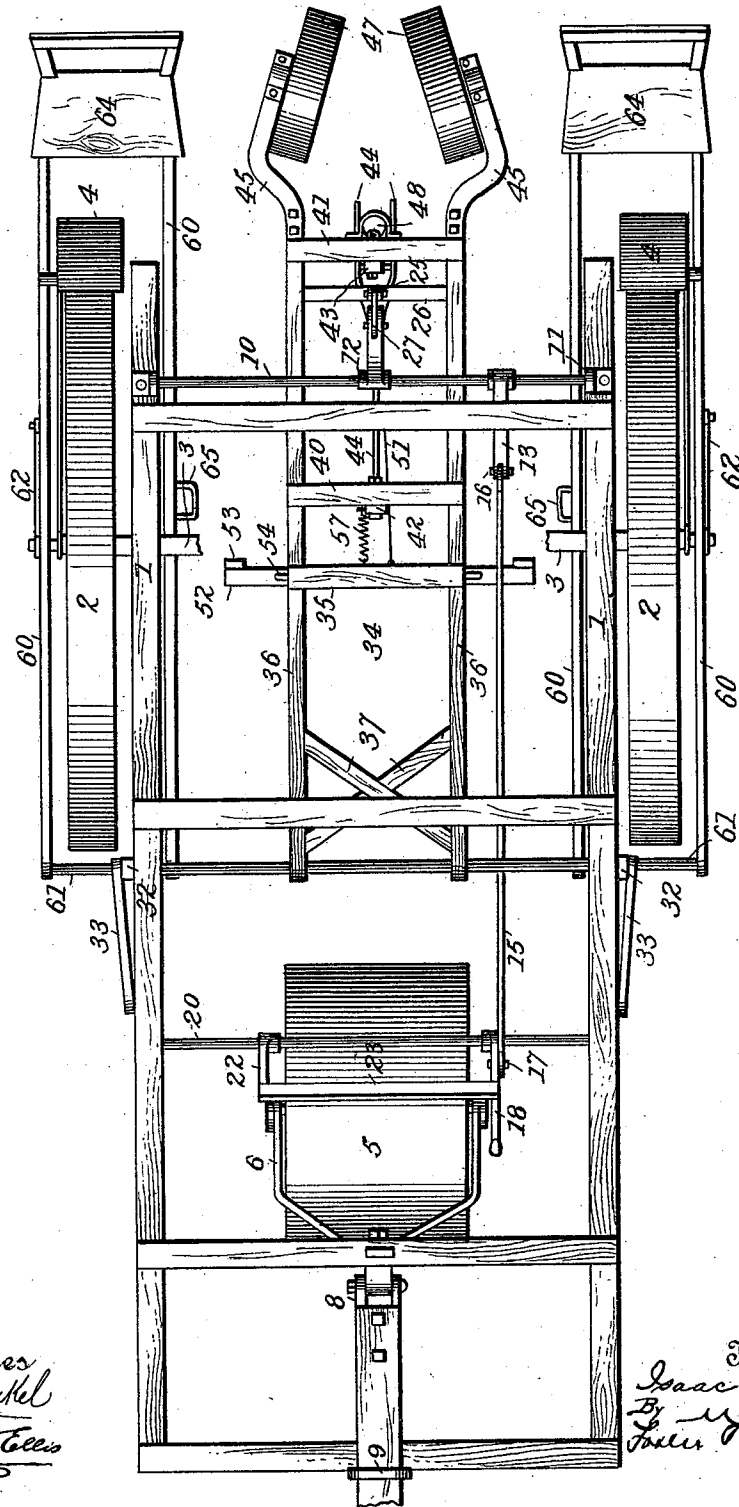

Witnesses
John H. Hinkel
E. C. Coates

Inventor
Isaac Unger
 By *Wm. Freeman*
 Attorneys

I. UNGER.
TOBACCO TRANSPLANTER.

No. 523,800.

Patented July 31, 1894.

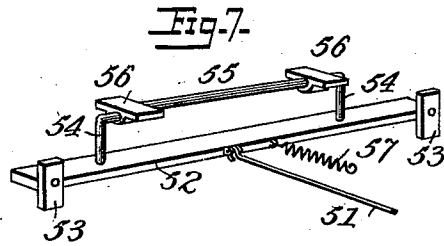
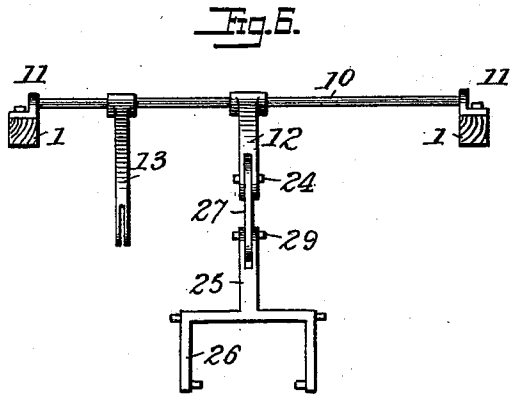
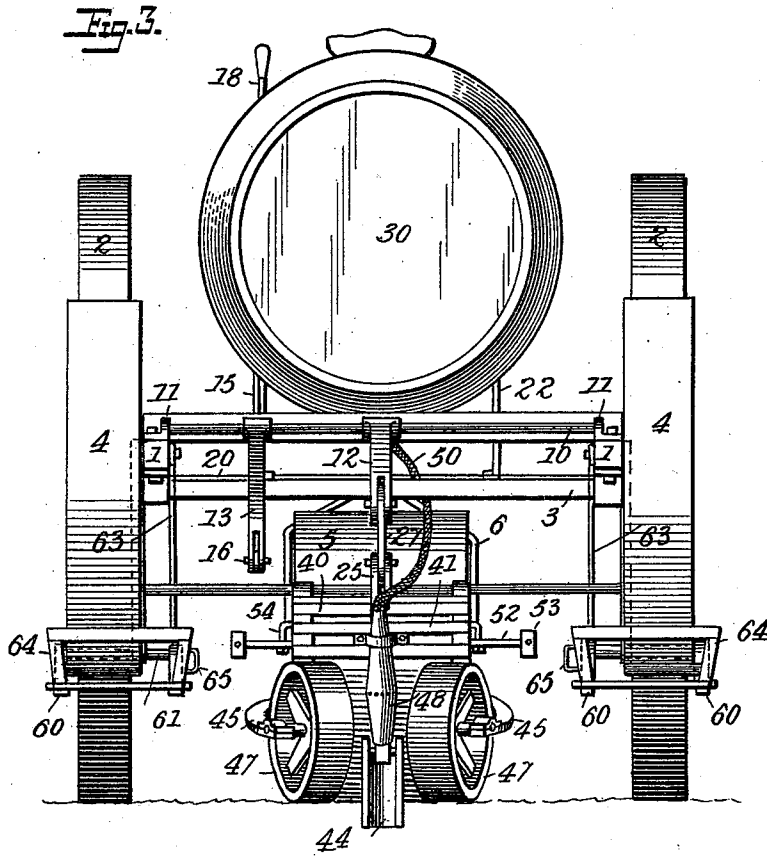

Witnesses
Jud. Hinkel
Edward Beer

Inventor
Isaac Unger
 By *John Freeman*
 Attorneys

I. UNGER.
TOBACCO TRANSPLANTER.

No. 523,800.

Patented July 31, 1894.

Fig. 4.

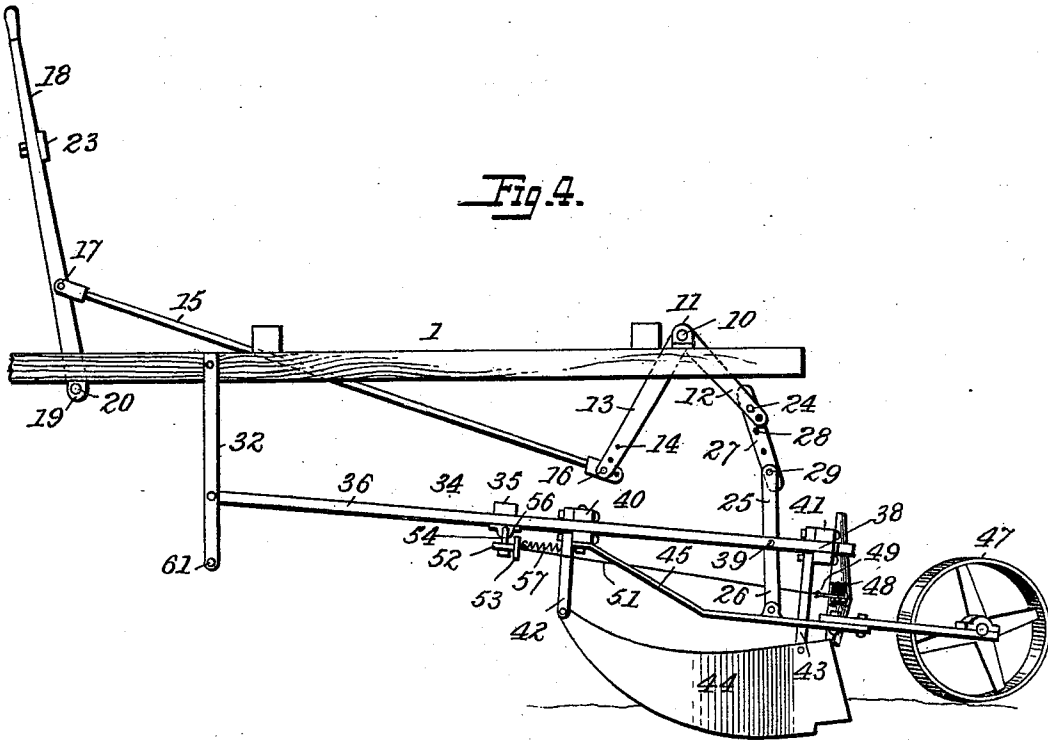
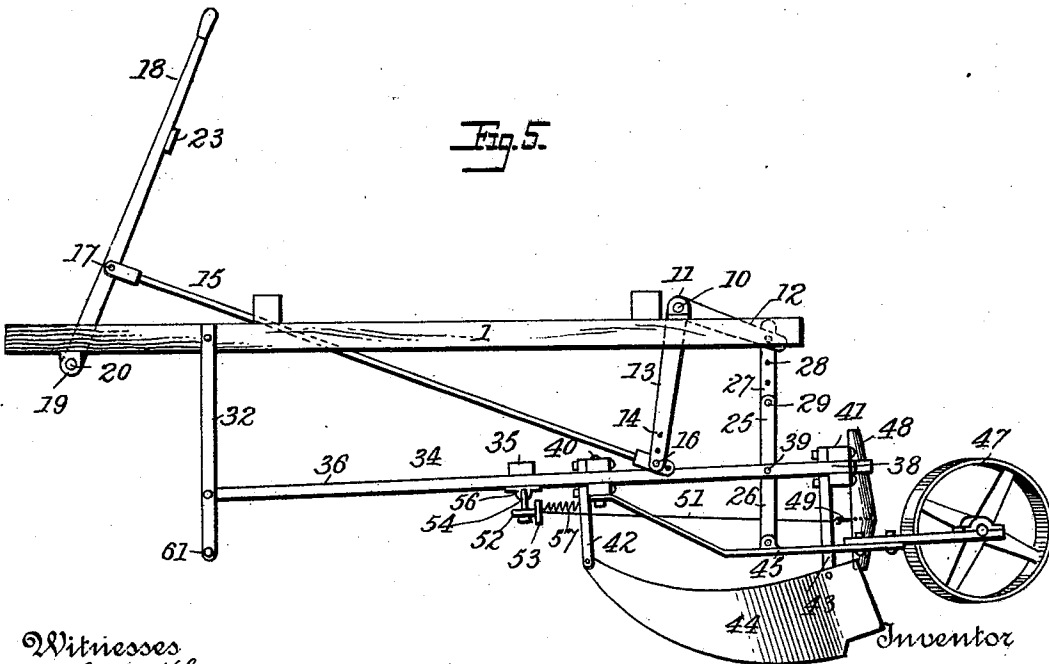

Fig. 5.



Witnesses
Jno. G. Hinkel
Charles Ellis

Inventor
By Isaac Unger
Justin Freeman
 Attorneys

UNITED STATES PATENT OFFICE.

ISAAC UNGER, OF ARCANUM, OHIO.

TOBACCO-TRANSPLANTER.

SPECIFICATION forming part of Letters Patent No. 523,800, dated July 31, 1894.

Application filed February 6, 1894. Serial No. 499,287. (No model.)

To all whom it may concern:

Be it known that I, ISAAC UNGER, a citizen of the United States, residing in Arcanum, in the county of Darke and State of Ohio, have
5 invented certain new and useful Improvements in Tobacco-Transplanters, of which the following is a specification.

This invention relates to certain new and useful improvements in machines for setting
10 or placing tobacco and other small plants; and it consists substantially in such features of construction, arrangement, and combinations of parts as will hereinafter be more particularly described.

15 The invention has for its object to provide a machine of this character which shall be under perfect control of the operator, and one in which the setting and watering of the plants can be easily and quickly effected.

20 A further object of the invention is to enable the driver or other operator with but little exertion to cause the plow and packing-rollers to bear down to their work with the desired degree of pressure.

25 A further object of the invention is to provide for rapidly elevating the plow, packing-rollers, and their appurtenances, so as to enable the machine to be readily turned around or moved over fields to the place of use.

30 A still further object of the invention is to provide a machine of the character referred to which shall be comparatively simple in construction and operation, one in which the parts shall always be reliable and effective,
35 and also a machine which shall exert less strain upon the horses in pulling, besides being easy of repair and manipulation.

In the accompanying drawings: Figure 1 is a side elevation of a plant-setting machine
40 embodying my improvements. Fig. 2, is a plan view thereof, with the water tank and some of the other parts removed, by which the construction and general arrangement will be more fully understood. Fig. 3 is a
45 rear end elevation. Fig. 4 is a skeleton-like side view, showing the position and arrangement of the several operative parts when the plow and packing-rollers are down to their work. Fig. 5 is a similar view, representing
50 the positions assumed by the several operative parts when the plow and packing-rollers have been lifted or elevated. Figs. 6 and 7

are detail views to more clearly indicate the construction and operation of certain parts hereinafter more specifically referred to. 55

It may be here stated that in order to carry my invention into effect, I am not obliged to employ expensive or complicated contrivances or devices, as for instance, the water-tank may consist of an ordinary hogshead, 60 while the main supporting frame is constructed very much the same as is employed in many other classes of vehicles.

The driver sits upon the tank in a position at the forward part of the machine, and a
65 maximum pressure is communicated to the plow and rollers through intermediate mechanism by means of the foot. While the parts of the machine are down, the work of furrowing, watering, and covering the plants
70 with earth will be thoroughly effected, and when desired to elevate said parts, it is done by a single movement of a hand-lever.

Referring to the drawings, 1, 1, represents the main frame of the machine, and 2, 2, the
75 supporting wheels thereof, which latter, as shown, turn upon a suitable axle 3, supported transversely of the frame. The said supporting wheels are preferably provided with
80 guards 4, 4, which may be supported in any suitable manner.

5, represents a caster-wheel supporting the forward part of the main frame, and which wheel is supported in a curved bracket 6,
85 which is provided with a series of holes, 7, for adjustable attachment to the forward part of the main frame, so as to enable such part of the frame to be elevated or lowered in conformity with the nature of ground traveled
90 over. The rear end of the shaft has a movable connection 8, and is embraced by a clevis 9, to prevent the same moving upward too far.

10, represents a rock-shaft having its bearings in staples 11, or other suitable boxes, arranged on top of the supporting frame 1, 1,
95 and the said shaft is provided with a crank-arm 12, carried about centrally thereof, and an additional crank-arm 13, set at an angle to the first, see Figs. 1, 4 and 5. The arm 13, is provided at its end with a series of openings
100 14, to form an adjustable movable connection with the rear end of the operating rod 15, a small pin or bolt 16, uniting the two, and it is evident that such connection can be made so

as to effect a greater or less throw whenever said operating rod is drawn or forced backward, and vice versa. Forwardly, the operating-rod 15 is movably connected at 17, to an operating hand-lever 18, which is pivoted at 19 to a cross-rod 20, extending between the two frame-pieces 1, 1. Opposite to said hand-lever on the same cross-rod but nearer to the opposite frame-piece 1, is also a pivoted rod 22, which together with the hand-lever supports or carries a foot-board 23, for the feet of the driver, and thus is constituted what may be termed a frame which firmly holds such board and which is swung with the lever when the latter is operated.

The crank-arm 12, of the rock-shaft 10, is movably and adjustably connected at 24, to a projecting arm 25, from a rectangular or other suitably shaped frame or yoke 26, by means of a link or coupling iron 27, provided with a series of holes or openings 28, through which the attachment is effected by means of a pin or bolt 29.

It is evident that when the rock-shaft 10 is turned in its bearings by a backward thrust or lunge of the operating connecting rod 15, the crank-arm 12, will be thrown or drawn upwardly, as indicated in Fig. 5, and the said frame or yoke will be carried upward with such crank-arm. The degree of movement can be easily and quickly regulated or adjusted by changing the point of connection with the link or coupling-iron 27.

30 represents the water-tank which is provided with a seat at its forward end, and which also is provided with a catch or lock 31, which receives and holds the handle-lever whenever the same has been drawn backwardly to move the operating connecting-rod.

The plow and the packing rollers are held down to their work through power applied by the foot of the operator, which gives the advantage to the driver of permitting the parts to yield to roughness or irregularities of surface traveled over. In this way all plants in a line or row may be evenly set or placed.

Pendent from each of the frame-pieces 1, 1, is an arm 32, which is securely braced by an angle-piece 33, fastened by one end to the arm and by its other end to the frame. Pivoted or swung to the said pendent arms and working between the same toward the center of the machine is a frame 34, constituted of the cross-pieces 35, and the longitudinal members 36, 36. The latter are connected by strong braces 37 and they extend back somewhat beyond the yoke or frame 26, leaving projecting portions 38, as shown. Said members 36, are movably connected at 39, to the vertical sides of said frame or yoke 26, and the entire frame 34 (of which these members constitute a part, as stated) serves to sustain the weight of the parts when the plow and rollers are raised or lifted. The portions or members 36, of said pivoted or swinging frame 34, are connected together about centrally by a strip 40, and are similarly connected at or

near their rear ends by an additional strip 41. These connecting strips serve to strengthen said frame. Pendent from each of said strips 40, 41, rigid therewith and about centrally of the machine, are the hangers 42 and 43, which support at their lower ends the plow or cutter 44, the latter being of any preferred construction to cut a furrow in the ground deep enough for the purpose desired.

Secured to the ends of the yoke or frame 26, by suitable bolts, are angle-pieces 45, 45, the inner ends of which extend up beneath the brace-strip 40, of the swung frame 34, to which they are also firmly secured. Attached firmly to the outer ends of the angle-pieces 45 are the bearing-forks 46, 46, which carry the packing rollers 47, 47, which latter are arranged at an angle to each other, as shown, which gives them a tendency to throw the dirt or loose earth inwardly upon the roots of the plants.

Fastened intermediate of the plow or cutters and the packing rollers is the watering-pot or nozzle 48, the same being hollow and provided with a suitable push valve 49, adapted to be opened to let water flow to the plants. Said pot or nozzle is in communication with the lower end of preferably a flexible water-pipe 50, leading from any suitable part of the water-tank, as shown. The said valve 49, is normally closed, but is connected to one end of a strong wire 51, the other end of which is connected centrally with a loose rod 52, having a foot-piece 53, at each end thereof. The said loose rod 52, is fastened on opposite sides of its center to the bent or turned ends 54, 54, of a frame 55, which is loosely held or supported in bearings 56, secured to the under side of the members 36, of the frame 34.

A spring 57, having one end connected to the rod 52, and the other end fastened to one of the cross braces of said frame 34, tends to hold the said rod 52 up tightly against the under side of frame 34, and also to keep the valve of the watering-pot closed.

It is evident that by placing the foot on either one of the foot-pieces 53, and pressing downwardly, the valve will be opened sufficiently to allow a quantity of water to flow to the plants, and that the action of the spring will again close said valve when the pressure of the foot is removed from the rod. By pressing upon the rod in the manner stated, the latter is carried down or swung away from the under side of frame 34, but when released, it flies back to its place.

Extending longitudinally of the machine to each side of each of the supporting wheels 2, 2, are the parallel rods or beams 60, the forward ends of which are attached to and supported by the ends of small shafts 61, passing through the pendent arms 32 of the main frame; and these rods or beams 60 are further supported at or near their centers or at any suitable point near their rearward ends by other suitable supports. Preferably they

are supported by rigid arms 62 and 63, pendant respectively from the ends of the shaft or axle 3, and the side-pieces 1, 1 of the main frame, substantially in the manner shown.

5 The said parallel rods or beams 60, support at their rearward extremities suitable seats 64, upon which the persons who set the plants in the furrows may be seated while performing such work. Suitable stirrups 65, are provided on the sides of the beams 60, and upon
10 these stirrups the feet of the operators may be rested while at work.

From the foregoing description, it is thought the construction and arrangement of my invention will be fully understood. It will be
15 seen that the plow and rollers can be easily and quickly raised and lowered by the driver or operator, and that when lowered the parts may be easily kept down to their work with
20 but little exertion.

It will further be seen that the parts are all reliable in operation; that the machine is simple and strong, and that the same is thoroughly operative and effective for the purpose intended.
25

It is apparent that the details of construction and arrangement of parts could be varied, and therefore without limiting myself to the precise details shown and described,
30

I claim—

1. In a plant setting machine, the combination with the operating rod 15, of the cross rod 20, the hand lever working on said cross rod and movably connected with the operating rod, the pivoted rod 22 carried by the
35

cross rod at a point inside of or beyond the hand lever, and the foot board supported by said lever and pivoted rod, substantially as described.

2. In a plant setting machine, the combination with the rod 15, the rock shaft 10, and means for operating said rod, of the arm 13 extending inwardly from the rock shaft to which it is fixed, and provided at its inner end with openings for adjustable connection
45 with the rod 15, the yoke 26, the crank arm 12 on the shaft, the perforated coupling uniting said yoke and crank arm, the pivoted movable frame 34, and the plow suspended from said frame at the rear end thereof, substantially as described.
50

3. In a plant setting machine, the combination of the operating rod, the rock shaft, connections between said shaft and rod, the crank arm 12, the yoke movably connected to
55 the crank arm, the swinging or movable frame 34 connected to the yoke and carrying the plow, the angle arms also connected to the yoke and secured at their inner ends to said frame, and the bearing forks attached to said
60 angle arms and carrying the rollers arranged at an angle to each other, substantially as described.

In testimony whereof I have signed my name to this specification in the presence of
65 two subscribing witnesses.

ISAAC UNGER.

Witnesses:

M. N. TILMAN,
KIRK HOFFMAN.