

No. 704,635.

Patented July 15, 1902.

J. HARRIS.
GAS BURNER.

(Application filed Mar. 10, 1902.)

(No Model.)

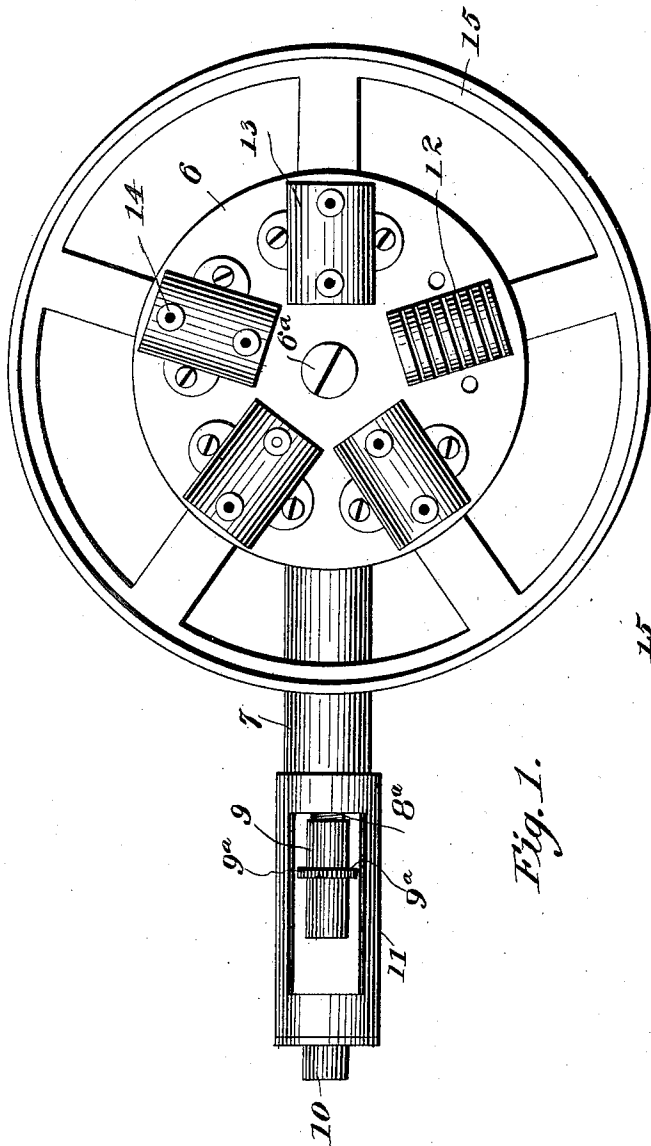

Fig. 1.

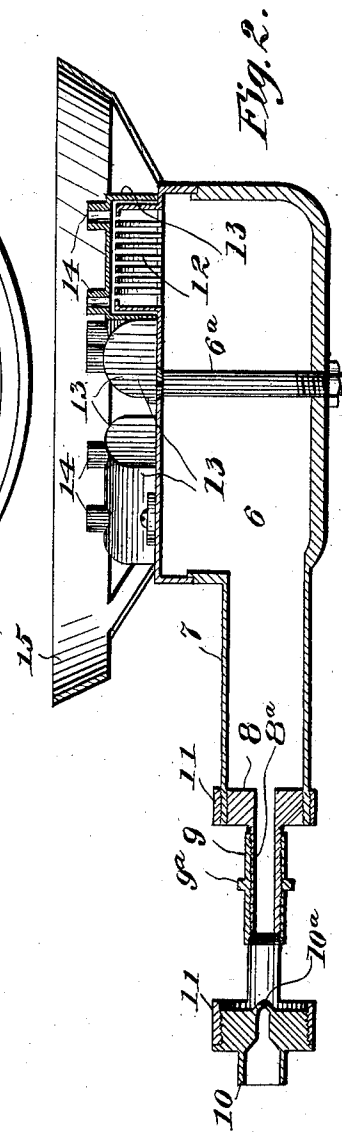

Fig. 2.

WITNESSES:

J. A. Baxter
Geo. E. Tew

INVENTOR

John Harris
BY
Milo B. Stevens & Co.
ATTORNEYS.

UNITED STATES PATENT OFFICE.

JOHN HARRIS, OF CLEVELAND, OHIO.

GAS-BURNER.

SPECIFICATION forming part of Letters Patent No. 704,635, dated July 15, 1902.

Application filed March 10, 1902. Serial No. 97,445. (No model.)

To all whom it may concern:

Be it known that I, JOHN HARRIS, a citizen of the United States, residing at Cleveland, in the county of Cuyahoga and State of Ohio, have invented certain new and useful Improvements in Gas-Burners; and I do hereby declare the following to be a full, clear, and exact description of the invention, such as will enable others skilled in the art to which it appertains to make and use the same, reference being had to the accompanying drawings, and to the figures of reference marked thereon, which form a part of this specification.

This invention relates to gas-burners, and particularly to burners for gas-stoves.

The object of the invention is to form a burner with which acetylene may be used for cooking or heating purposes.

A further object is to provide means for preventing overheating of the burner and flashing back of the flame.

A further object is to provide improved means for mixing air with the gas in the proper proportion to form perfect combustion.

In the use of acetylene for cooking or heating purposes it is important that the heat be kept below 600° Fahrenheit, because when that point is reached molecular changes take place which produce benzene vapor, which requires several times the quantity of air for proper combustion that acetylene does. It is the aim of my invention to accomplish this by locating the ignition-place as far as possible from the mixing-chamber and by a new and improved burner produce perfect and safe combustion of acetylene in a gas-stove.

Figure 1 is a top plan view of the burner, one of a number of burner-caps being removed to show an inner slotted barrier. Fig. 2 is a vertical section.

Referring specifically to the drawings, 6 indicates a mixing-chamber, the body and top of which are held together by a bolt 6^a. 7 indicates the supply-pipe thereto. This pipe is reduced at the air-inlet valve by a bushing 8, having a projecting neck 8^a, which is threaded for the sleeve 9, adjustable thereon.

The gas-supply pipe is indicated at 10 and has a nipple 10^a directed into the sleeve in proximity to the open end thereof and to the mouth of the neck 8^a. The air enters at the open end of the sleeve around the nipple and mixes with the gas discharged therefrom.

The amount of air may be regulated by adjustment of the sleeve, increasing or decreasing its distance from the nipple. A milled rim 9^a is provided on the sleeve to facilitate its manipulation. A frame 11 is fitted to the ends of the supply and gas pipes to properly space and support the same.

The top of the mixing-chamber has a number of discharge-openings, over which are finely-slotted covers 12, which in turn are covered and inclosed by chambered caps 13, fitted and screwed to the top of the mixing-chamber. These caps have ignition-nipples 14.

15 indicates a ring to support a grating above the flame in the usual manner.

By the construction above described the gases are mixed in the supply-pipe and mixing-chamber and also in the chambers of the caps. Flashing back or ignition in the mixing-chamber is prevented by the slotted covers 12, which act as safety-barriers to prevent transmission of the flame. They also assist in the proper supply and mixture of the gas.

It is to be understood that I do not limit my invention to the exact form and construction herein shown and described. The provision of a safety-barrier in the passage between the flame and the mixing-chamber permits acetylene to be used as fuel for gas-stoves and also forms a safe and useful burner for any other gas.

Having thus described the invention, what I claim as new, and desire to secure by Letters Patent, is—

1. The combination, in a gas-burner, of a mixing-chamber having discharge-openings in the top thereof, a slotted cover over each of said openings, and chambered caps fitted to the top of the mixing-chamber and entirely inclosing said covers, said caps having ignition-nipples spaced from the slotted covers.

2. The combination in a gas-burner, of a mixing-chamber having discharge-openings, covers having small apertures over said openings, and chambered caps inclosing each of said covers and having ignition-nipples.

In testimony whereof I affix my signature in presence of two witnesses.

JOHN HARRIS.

Witnesses:

LOTTIE NEWBURN,
JOHN A. BOMMARDT,