

April 12, 1955

H. M. PONT

2,705,928

BUILDING STRUCTURES

Filed Feb. 12, 1951

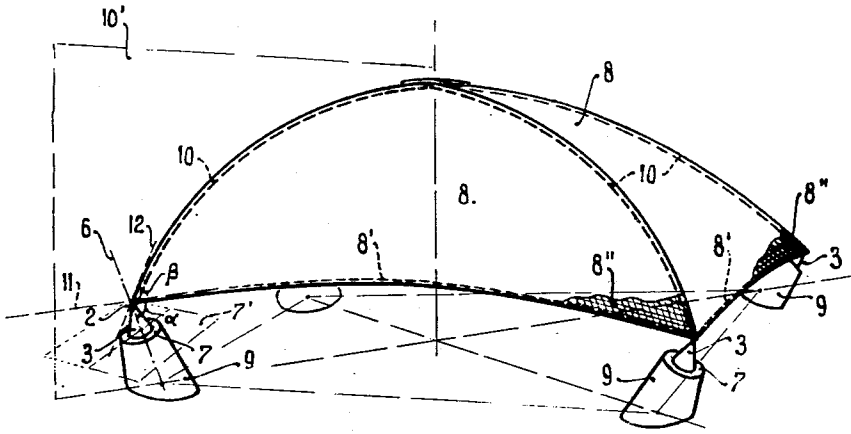

FIG. 1

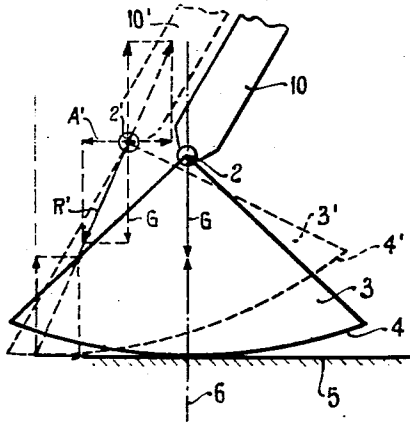

FIG. 2

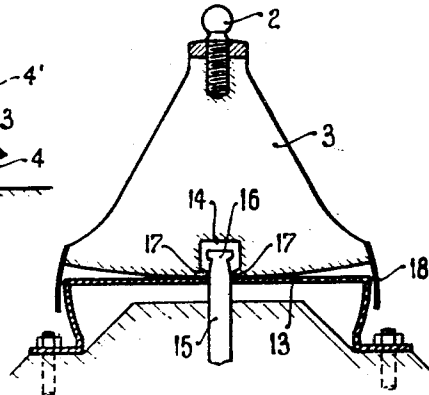

FIG. 3

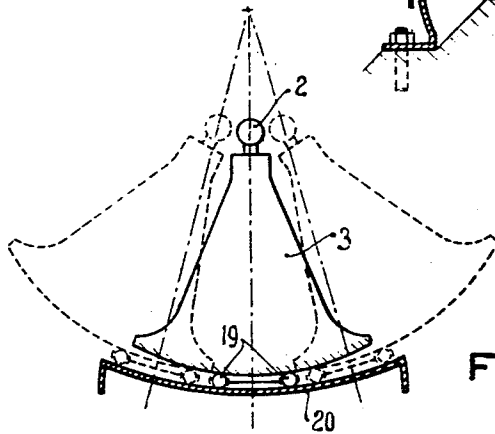

FIG. 4

Henri Maclaine PONT

INVENTOR

BY *Stevens, Davis, Miller & Mooker*  
ATTYS.

1

2,705,928

**BUILDING STRUCTURES**

Henri Maclaine Pont, Voorburg, Netherlands

Application February 12, 1951, Serial No. 210,510

Claims priority, application Netherlands March 9, 1950

6 Claims. (Cl. 108—1)

The invention relates to a large span roof of the elastic type described in applicant's copending applications Nos. 759,584 and 759,585 both filed on July 8, 1947, and now Patents 2,545,556 and 2,592,465 respectively and comprising self-adjusting supports at the corners of the roofed space only, resiliently flexible curved rafter principals which bear upon the supports, meet in the top of the roof and are turned with their concave sides towards the inside, eaves-cables provided round about the roof on the level of the lower ends of said rafter principals, networks provided in the roofing planes between said principals and said eaves-cables and a roof covering supported directly by said roofing networks.

The invention has for a primary object to so improve such elastic roofs, which have already the tendency to restore by their weight the state of equilibrium, as to obtain an equal distribution of the stresses set up by forces from the outside, say by the wind, in all sides of the roofs. It consists in that the self-adjusting supports include movable supporting elements and stationary supporting members, the lower end of each rafter principal being hingedly connected to such a movable supporting element by a ball joint and each of said supporting elements having a curved sole-surface bearing on a stationary supporting member, which permits each movable element to perform a restricted rolling movement in all directions on the supporting face of its stationary member, the main axis of each movable supporting element containing the center of the corresponding ball joint, and each ball joint is situated at a greater distance from the supporting face of the stationary supporting member in any position of the supporting element differing from the position of preference than in said latter position, said position of preference being defined by the fact that only in that position the said axis of revolution is at right angles to the supporting face of the stationary supporting member.

Movement of the supporting elements from the position of preference raises the roof and/or tightens the eaves cables, so that the weight of the roof and/or the tension of the eaves cables tend or tends to keep the supporting elements in their positions of preference or to bring them back into said positions. Moreover the rafter principals are free to adjust themselves to the stresses exerted in the roof structure and therefore they will assume positions in which the stresses will be equally distributed round about the roof, even when the forces from the outside are exerted on one side of the roof only.

If the supporting elements are placed on supporting faces which are in an inclined plane sloping towards the outside and, transverse to such plane, are at right angles with the vertical plane containing the curved rafter principals, they are able to exert horizontal stretching or tautening forces on the elastic roof, which forces are dependent on the weight of the roof.

In an embodiment of the invention balls may be interposed between the sole-surface of each supporting element and the supporting face of each stationary member. This embodiment has the advantage, that the pressure exerted by a supporting element on a supporting face is distributed over a great number of balls, that means is not concentrated in one single point any more.

These and other features of the invention will be elucidated by means of the following description and the accompanying drawing, in which:

Fig. 1 is a diagrammatical perspective view of a roof of large span supported in its corners by movable self-

2

adjusting supporting elements, which bear upon inclined supporting faces of stationary members,

Fig. 2 is a diagrammatical view of one of the movable supporting elements of Fig. 1 bearing on a horizontal supporting face in two different positions,

Fig. 3 is a sectional view of a movable supporting element and a corresponding stationary supporting member, in which the element is coupled with said member and the supporting face of the latter is made elastic, and

Fig. 4 is a sectional view of another embodiment of the invention in which the supporting element is placed with its sole-surface on balls, which are adapted to roll on a curved supporting face.

Fig. 1 illustrates a roof of large span and elastic structure of the type described in the copending U. S. specifications 2,545,556 and 2,592,465. This roof, consisting of rafter principals 10, eaves-cables 8', networks 8'' and a roof covering 8, bears on corner supports, each of which consists of a stationary supporting member 9 having an inclined supporting face 7, which is contained in a plane 7' sloping towards the outside and directed, transversely of such inclined plane, at right angles to the vertical plane 10' containing the curved rafter principal 10 in question, and a supporting element 3 in the shape of a spherical sector-like bearing with its spherical sole-surface 4 on said supporting face 7. The apex 2 of said supporting element is connected by a ball joint to the foot or lower end of the rafter principal 10. In the neutral position or the position of preference the angle  $d$  enclosed by the main axis 6 of the supporting element 3 and the horizontal plane intersecting the vertical plane in the line 11 is equal to the angle B enclosed by said line 11 and the tangent 12 to the foot of the curved rafter principal 10.

Fig. 2 illustrates on a larger scale a movable supporting element which is similar to the element shown in Fig. 1. Said element has the shape of a spherical sector-like portion and bears in this case with its spherical sole-surface 4 on a horizontal supporting face 5 of the stationary supporting member. The distance between the apex 2 of the element 3, said apex being the center of the ball joints, and any point of the sole-surface 4 is smaller than the radius of said sole-surface so that the supporting element is not a true sector but is only sector-like in appearance.

When a force is exerted in horizontal direction on the roof 8, for instance by the wind, the supporting elements 3 perform a restricted true rolling movement on the supporting face 5 and they are adjusted in a position, in which the sum of the forces exerted in horizontal direction on the roof by said supporting elements is equal and contrary to the original force exerted on the roof.

Fig. 2 shows that in the case of the horizontal support the apex 2 is raised, so that the roof 8 is lifted, when the supporting element 3 is rolled with its sole-surface 4 over the base 5. In this case the supporting element 3 will be brought into a position, in which the resultant R' of the force A', which is laterally exerted on the apex 2' of the supporting element and for instance is set up by the wind, and the weight G of the roof is directed towards the point of contact between the sole surface 4 and the supporting face 5. Since the weight G is constant the deviation from the position of preference, which is shown in Fig. 2 in continuous lines, will increase, when the lateral force A is increased. In the position of preference the lateral force A has the value zero. Thus the supporting elements tend to bring the roof back into its position of preference, in which position said roof is on its lowest level.

If the supporting element 3 is positioned on an inclined supporting surface 7 as is illustrated in Fig. 1 the above described self-adjusting effect of the supports of the roof will also be obtained. In that case the apex 2 of a supporting element will move away from the apices of adjacent supporting elements during its downward rolling movement, said rolling movement thus being counteracted by the stress set up in the eaves-cables, and said apex will move upwards during its upward rolling movement, said latter movement thus being counteracted by the weight of the roof. In both cases, there will be generated a force which will tend to return the supporting element into its position of preference. It will be apparent that in the case of the sloping support of the supporting elements

3

these elements have a permanent tautening action on the roof structure.

In Fig. 3 the supporting element 3 rests with its sole surface 4 on a supporting surface in the form of a plate 13, which is supported on the marginal portion only. This plate is a little bent by the weight to be supported, so that the contact between the supporting element and the supporting face has the shape of an area instead of being a point only. The specific pressure is considerably reduced by this measure. The plate 13 operates as the membrane of a drum.

In order to prevent sliding movement of the supporting element, said element 3 may be provided with a recess 14 and the base may have a peg 15, which engages said recess. The peg is provided with a head 16 forming an abutment for an annular rib 17 at the edge of said recess which delimits the rolling movement of the supporting element from its position of preference. In order to keep the supporting surface free from dirt and dust the supporting element 3 is provided with a screen 18 suspending from the circumference of the sole-surface of the supporting element.

In Fig. 4 the supporting element 3 is positioned on balls 19, which are supported by a curved supporting surface 20. Also in this case, in which the supporting element performs both a rolling movement and a translatory movement, the conditions must be so chosen, that the apex of the supporting element always moves in a direction having a component pointing from the supporting surface, when the supporting element is rolled from its position of preference. The use of balls gives more points of contact that the direct support, so that the specific pressure is reduced.

A curved supporting surface may also be used in the embodiment according to Figs. 1, 2 and 3. It is not necessary that the sole-surfaces of the supporting elements are spherically curved. Said sole-surfaces may also be curved otherwise and may for instance have the shape of a parabola, an ellipse, a hyperbola or the shape of a portion of the surface of another body of revolution.

What I claim is:

1. A roof of large span comprising, in combination, self-adjusting supports at the corners of the roofed space only, resiliently flexible curved rafter principals which bear upon the supports, meet in the top of the roof and are turned with their concave sides towards the inside, eaves-cables provided round about the roof on the level of the lower ends of said rafter principals, networks provided in the roofing planes between said principals and said eaves-cables and a roof covering supported directly by said roofing networks, said self-adjusting supports including movable supporting elements and stationary supporting members, a ball joint hingedly connecting the lower end of each rafter principal to a movable supporting element, each of said supporting elements having a curved sole surface bearing on a stationary supporting

4

member, which permits each movable element to perform a restricted rolling movement in all directions on the supporting face of its stationary member, the main axis of each movable supporting element containing the center of the corresponding ball joint and each ball joint being situated at a greater distance from the supporting face of the stationary supporting member in any position of the supporting element differing from the position of preference, the position of preference being defined as the position of the supporting element when the said axis is at right angles to the supporting face of the stationary supporting member.

2. A roof of large span as claimed in claim 1, characterized in that a recess opening towards the sole surface of the movable supporting element is formed in said element and is provided at its edge with an annular rib narrowing said opening and a peg having an enlarged head carried by the supporting face of the stationary supporting member and having its head received in said recess of the movable supporting element, said annular rib surrounding the opening of the recess abutting the head of said peg, when the movable supporting element is deviated maximally from its position of preference.

3. A roof of large span as claimed in claim 1, characterized in that balls are interposed between the sole surface of the movable supporting element and the supporting face of the stationary member.

4. A roof of large span as claimed in claim 1, characterized in that the supporting face of each stationary member is contained in an inclined plane sloping downwardly towards the outside and at right angles transverse of said inclined plane, with the vertical plane containing the corresponding curved rafter principal.

5. A roof of large span as claimed in claim 1, characterized in that the supporting face of the stationary member is constituted by a flexible plate having a circumference and being supported on said circumference only.

6. A roof of large span as claimed in claim 1, characterized in that the supporting face of the stationary member is curved.

#### References Cited in the file of this patent

##### UNITED STATES PATENTS

311,338	Lindenthal	Jan. 27, 1885
592,852	Westwood	Nov. 2, 1897
2,014,643	Bakker	Sept. 17, 1935
2,208,872	Ropp	July 23, 1940
2,359,036	Harper	Sept. 26, 1944
2,545,556	Pont	Mar. 20, 1951

##### FOREIGN PATENTS

266,568	Italy	1929
367,847	Italy	1939