



INTERNATIONAL APPLICATION PUBLISHED UNDER THE PATENT COOPERATION TREATY (PCT)

<p>(51) International Patent Classification 5 : B65D 83/54</p>	<p>A1</p>	<p>(11) International Publication Number: WO 93/22221 (43) International Publication Date: 11 November 1993 (11.11.93)</p>
<p>(21) International Application Number: PCT/US93/04328 (22) International Filing Date: 3 May 1993 (03.05.93) (30) Priority data: 07/878,041 4 May 1992 (04.05.92) US (71) Applicant: MINNESOTA MINING AND MANUFACTURING COMPANY [US/US]; 3M Center, Post Office Box 33427, Saint Paul, MN 55133-3427 (US). (72) Inventor: MARECKI, Paul, E. ; Post Office Box 33427, Saint Paul, MN 55133-3427 (US). (74) Agents: REEDICH, Douglas, E. et al.; Office of Intellectual Property Counsel, Minnesota Mining and Manufacturing Company, Post Office Box 33427, Saint Paul, MN 55133-3427 (US).</p>		<p>(81) Designated States: AU, CA, JP, NZ, European patent (AT, BE, CH, DE, DK, ES, FR, GB, GR, IE, IT, LU, MC, NL, PT, SE). Published <i>With international search report. Before the expiration of the time limit for amending the claims and to be republished in the event of the receipt of amendments.</i></p>
<p>(54) Title: DEVICE FOR DELIVERING AN AEROSOL</p>		
<p>(57) Abstract</p> <p>A device for delivering an aerosol, comprising: a casing member (14), a valve stem (12), and a diaphragm (16), wherein the diaphragm comprises a styrene-ethylene/butylene-styrene block copolymer. Also disclosed are sealing members, e.g., for use in sealing an aerosol canister. The devices of the invention are particularly useful with formulations containing 1,1,1,2-tetrafluoroethane or 1,1,1,2,3,3,3-heptafluoropropane as the propellant.</p>		

FOR THE PURPOSES OF INFORMATION ONLY

Codes used to identify States party to the PCT on the front pages of pamphlets publishing international applications under the PCT.

AT	Austria	FR	France	MR	Mauritania
AU	Australia	GA	Gabon	MW	Malawi
BB	Barbados	GB	United Kingdom	NL	Netherlands
BE	Belgium	GN	Guinea	NO	Norway
BF	Burkina Faso	GR	Greece	NZ	New Zealand
BG	Bulgaria	HU	Hungary	PL	Poland
BJ	Benin	IE	Ireland	PT	Portugal
BR	Brazil	IT	Italy	RO	Romania
CA	Canada	JP	Japan	RU	Russian Federation
CF	Central African Republic	KP	Democratic People's Republic of Korea	SD	Sudan
CG	Congo	KR	Republic of Korea	SE	Sweden
CH	Switzerland	KZ	Kazakhstan	SK	Slovak Republic
CI	Côte d'Ivoire	LI	Liechtenstein	SN	Senegal
CM	Cameroon	LK	Sri Lanka	SU	Soviet Union
CS	Czechoslovakia	LU	Luxembourg	TD	Chad
CZ	Czech Republic	MC	Monaco	TG	Togo
DE	Germany	MG	Madagascar	UA	Ukraine
DK	Denmark	ML	Mali	US	United States of America
ES	Spain	MN	Mongolia	VN	Viet Nam
FI	Finland				

DEVICE FOR DELIVERING AN AEROSOLTechnical Field

This invention relates to devices for
5 delivering aerosols. In another aspect this invention
relates to sealing members. In yet another aspect this
invention relates to sealing members for use in devices
for delivering aerosols. This invention also relates
to thermoplastic polymer blends.

10

Description of the Related Art

The continuing use of aerosol formulations
comprising conventional chlorofluorocarbon propellants
is being debated due to the suspected role of such
15 propellants in atmospheric depletion of ozone.
Accordingly, alternative propellants such as HFC-134a
(1,1,1,2-tetrafluoroethane) and HFC-227 (1,1,1,2,3,3,3-
heptafluoropropane) are being developed to replace
those conventional propellants thought to contribute to
20 atmospheric ozone depletion.

Containers for aerosol formulations commonly
include a rubber valve seal intended to allow
reciprocal movement of the valve stem while preventing
leakage of propellant from the container. These rubber
25 valve seals are commonly made of thermoset rubbers such
as butyl rubber, butadiene-acrylonitrile rubbers,
("Buna") and neoprene (polychloroisoprene), which are
compounded with vulcanizing agents prior to being
fashioned into valve seals.

30

Summary of the Invention

It has been found that some conventional
devices for delivering aerosols suffer impaired
performance when used in connection with HFC-134a
35 and/or HFC-227. Accordingly, this invention provides a
device for delivering an aerosol, comprising: a valve
stem, a diaphragm having walls defining a diaphragm
aperture, and a casing member having walls defining a

casing aperture, wherein the valve stem passes through the diaphragm aperture and the casing aperture and is in slidable sealing engagement with the diaphragm aperture, and wherein the diaphragm is in sealing engagement with the casing member, the diaphragm material comprising a thermoplastic elastomer comprising styrene-ethylene/butylene-styrene block copolymer. The thermoplastic elastomer optionally further comprises a polyolefin such as polypropylene, and further optionally comprises a siloxane such as polydimethylsiloxane or polymethyloctylsiloxane. In a preferred embodiment the diaphragm material exhibits a leak rate of less than about 2500 mg/yr when tested according to the Leak Rate Test Method set forth herein.

This invention also provides a metered-dose device for delivering an aerosol that comprises, in addition to the above-discussed valve stem, diaphragm, and casing member, a tank seal having walls defining a tank seal aperture, and a metering tank of a predetermined volume and having an inlet end, an inlet aperture, and an outlet end, wherein the outlet end is in sealing engagement with the diaphragm, the valve stem passes through the inlet aperture and the tank seal aperture and is in slidable engagement with the tank seal aperture, and the tank seal is in sealing engagement with the inlet end of the metering tank, and wherein the valve stem is movable between an extended closed position, in which the inlet end of the metering tank is open and the outlet end is closed, and a compressed open position in which the inlet end of the metering tank is substantially sealed and the outlet end is open to the ambient atmosphere.

In a preferred embodiment the casing member defines a formulation chamber, and in a further preferred embodiment the formulation chamber contains an aerosol formulation comprising a propellant, said propellant comprising 1,1,1,2-tetrafluoroethane,

-3-

1,1,1,2,3,3,3-heptafluoropropane, or a mixture thereof.

In another aspect, this invention provides a thermoplastic elastomeric sealing member, e.g., for maintaining a desired atmosphere in a sealed chamber or
5 for minimizing and/or preventing escape of propellants, such as 1,1,1,2-tetrafluoroethane or 1,1,1,2,3,3,3-heptafluoropropane, from a sealed chamber. Such sealing members can be used as appropriate in connection with static seals or dynamic seals, with
10 pressurized or unpressurized systems, and with liquid or dry systems. In a preferred embodiment the sealing member is used in a dynamic seal in a pressurized system in order to prevent escape of formulation components, such as 1,1,1,2-tetrafluoroethane or
15 1,1,1,2,3,3,3-heptafluoropropane, from a device for delivering an aerosol.

Devices and sealing members of this invention find use in connection with aerosol formulations involving HFC-134a or HFC-227 as a propellant as well
20 as with formulations containing other propellants such as chlorofluorocarbon propellants. Conventional devices involving thermoset diaphragms of neoprene (polychloroprene), butyl rubber, or butadiene-acrylonitrile "buna" copolymers allow
25 excessive leakage of HFC-134a and HFC-227 from some formulations over time. Particularly in low volume formulations such as pharmaceutical formulations for use in inhalation therapy, this leakage can cause a substantial increase in concentration of the active
30 ingredient in the formulation, resulting in delivery of an improper dose. Furthermore, with some formulations the valve stem tends to stick, pause, or drag during the actuation cycle when neoprene or butadiene-acrylonitrile "buna" diaphragms are used.
35 Leakage and smoothness of operation are improved in the devices of the invention compared to like devices involving the conventional diaphragm materials. Hence this invention is particularly desirable for use with

aerosol formulations wherein the propellant comprises HFC-134a, HFC-227, or a mixture thereof. Moreover, the thermoplastic elastomers used in the sealing members of the invention are not compounded with vulcanizing agents and therefore they are free of complications that might arise from contamination by leaching of such vulcanizing agents.

Brief Description of the Drawings

10 The drawing is represented by FIGS. 1 and 2. FIG. 1 is a partial cross-sectional view of one embodiment of a device of the invention, wherein the valve stem is in the extended closed position.

15 FIG. 2 is a partial cross-sectional view of the embodiment illustrated in FIG. 1, wherein the valve stem is in the compressed open position.

Detailed Description of the Invention

20 As used herein the term "thermoplastic elastomer" refers to a thermoplastic polymeric material that is capable of returning to essentially its original dimensions after deformation.

In order to minimize and/or prevent leakage of refrigerants, propellants, or other formulation components, especially propellants such as 1,1,1,2-tetrafluoroethane and 1,1,1,2,3,3,3-heptafluoropropane, from a sealed chamber, this invention provides thermoplastic elastomeric sealing members, i.e., sealing members that comprise a thermoplastic elastomer. In a preferred embodiment the thermoplastic elastomer exhibits a leak rate of less than about 2500 mg/year, preferably less than about 2000 mg/year, more preferably less than about 1000 mg/year, even more preferably less than about 500 mg/year, and most preferably less than about 300 mg/year when tested according to the Leak Rate Test Method set forth below.

The sealing member of the invention comprises a thermoplastic elastomer comprising styrene-ethylene/butylene-styrene block copolymer. The thermoplastic elastomer optionally further comprises a polyolefin, e.g., polypropylene, and further optionally comprises a siloxane such as polydimethylsiloxane or polymethyloctylsiloxane. These block copolymers preferably have a density between about 0.87 g/cm³ and about 0.97 g/cm³, more preferably between about 0.89 g/cm³ and 0.91 g/cm³. Shore A hardness is preferably between about 40 and about 95, more preferably between about 50 and about 75, and melt index is preferably about 0.3 g/10min to about 3 g/10min.

Thermoplastic elastomers used as seal materials according to this invention can also contain minor amounts of conventional polymer additives such as processing aids, colorants, lubricants, silica, talc, or mineral oil.

Certain suitable thermoplastic elastomers are commercially available. Others can be prepared using methods known to those skilled in the art and disclosed, e.g., in U.S. Pat. Nos. 4,386,179, 4,481,323, and 4,511,354. Preferred thermoplastic elastomers include:

KRATON™ G rubbers (Shell Chemical Co., Houston, TX) such as KRATON G 1657 rubber.

C-FLEX™ thermoplastic elastomer R70-001 (Concept Polymer Technologies), a material comprising a styrene-ethylene/butylene-styrene (SEBS) block copolymer modified with polypropylene, dimethylsiloxane, and mineral oil, and having a density of 0.90 g/cm³ and a melt index of 0.25 g/10 min.

C-FLEX™ thermoplastic elastomer R70-051, a material comprising a SEBS block copolymer modified with polypropylene, mineral oil, and polymethyloctylsilane as described in U.S. Pat. No.

4,613,640 (Deisler et al.), having a density of 0.90 g/cm³ and melt index of 2.7 g/10 min.

C-FLEX™ thermoplastic elastomer R70-041, a material comprising a SEBS block copolymer modified with polypropylene and polydimethylsiloxane having a density of 0.90 g/cm³.

C-FLEX™ thermoplastic elastomer R70-085, a material comprising a SEBS block copolymer modified with polypropylene, mineral oil, and siloxanes including polymethyloctylsiloxane and having a density of 0.90 g/cm³.

C-FLEX™ thermoplastic elastomer R70-003, a material comprising a SEBS block copolymer modified with polydimethylsiloxane, polypropylene, and mineral oil, having a density of 0.90 g/cm³.

C-FLEX™ thermoplastic elastomer R70-026, a material comprising a SEBS block copolymer modified with polypropylene, polydimethylsiloxane, and mineral oil, having a density of 0.90 g/cm³.

Blends of two or more thermoplastic elastomers described above in any proportion are also suitable. Such polymer blends can also comprise minor amounts of conventional polymer additives such as processing aids, colorants, lubricants, silica, talc, or mineral oil.

As illustrated in the TABLES below, some of the seal materials and sealing members of the invention are superior to others for use in the dynamic seal of a pressurized aerosol container. Those seal materials that are less than optimal for use in the exemplified systems can nonetheless find use, e.g., in connection with a different general type of drug or a different valve stem than exemplified, as a static seal in a pressurized system, or in a non-pressurized system having a dynamic seal. The TABLES below occasionally contain data that appear somewhat inconsistent with other data. These aberrant results are generally

-7-

attributable to failure of one or two vials in the test group.

The device of the invention will be described with reference to the Drawing. FIG. 1 shows device 10 comprising valve stem 12, casing member 14, and diaphragm 16. The casing member has walls defining casing aperture 18, and the diaphragm has walls defining diaphragm aperture 17. The valve stem passes through and is in slidable sealing engagement with the diaphragm aperture. The diaphragm is also in sealing engagement with casing member 14. Diaphragm 16 represents a thermoplastic elastomeric sealing member of the invention. Such a sealing member can be one piece or it can be in the form of a plurality of thinner layers arranged in a stack.

The illustrated embodiment is a device for use with pharmaceutical formulations. The diaphragm in the illustrated embodiment is a single piece of a thickness sufficient to form an effective seal with the casing member, preferably about 0.125 mm (0.005 inch) to about 1.25 mm (0.050 inch). It has an outside diameter of about 8.6 mm (0.340 inch), and an inside diameter sufficient to form an effective seal with the valve stem. As valve stems having an outside diameter of about 2.79 mm (0.110 inch) are commonly used, suitable diaphragm inside diameter can be in the range of about 2.03 mm (0.080 inch) to about 2.67 mm (0.105 inch). Diaphragm dimensions suitable for use with other general types of devices can be easily selected by those skilled in the art.

Valve stem 12 is in slidable engagement with diaphragm aperture 17. Helical spring 20 holds the valve stem in an extended closed position as illustrated in FIG. 1. Valve stem 12 has walls defining orifice 22 which communicates with exit chamber 24 in the valve stem. The valve stem also has walls defining channel 26.

In the illustrated embodiment casing member 14 comprises mounting cup 28 and canister body 30 and defines formulation chamber 32. The illustrated embodiment further comprises tank seal 34 having walls 5 defining tank seal aperture 35, and metering tank 36 having inlet end 38, inlet aperture 40, and outlet end 42. The metering tank also has walls defining metering chamber 44 of predetermined volume (e.g., 50 μ L). Outlet end 42 of metering tank 36 is in sealing 10 engagement with diaphragm 16, and valve stem 12 passes through inlet aperture 40 and is in slidable engagement with tank seal 34.

When device 10 is intended for use with a suspension aerosol formulation it further comprises 15 retaining cup 46 fixed to mounting cup 28 and having walls defining retention chamber 48 and aperture 50. When intended for use with a solution aerosol formulation retaining cup 46 is optional. Also 20 illustrated in device 10 is sealing member 52 in the form of an O-ring that substantially seals formulation chamber 32 defined by mounting cup 28 and canister body 30. Sealing member 52 preferably comprises the thermoplastic elastomer described above.

Operation of device 10 is illustrated in 25 FIGS. 1 and 2. In FIG. 1, the device is in the extended closed position. Aperture 50 allows open communication between retention chamber 48 and formulation chamber 32, thus allowing the aerosol formulation to enter the retention chamber. Channel 26 30 allows open communication between the retention chamber and metering chamber 44 thus allowing a predetermined amount of aerosol formulation to enter the metering chamber through inlet aperture 40. Diaphragm 16 seals outlet end 42 of the metering tank.

35 FIG. 2 shows device 10 in the compressed open position. As valve stem 12 is depressed channel 26 is moved relative to tank seal 34 such that inlet aperture 40 and tank seal aperture 35 are substantially sealed,

thus isolating a metered dose of formulation within metering chamber 44. Further depression of the valve stem causes orifice 22 to pass through aperture 18 and into the metering chamber, whereupon the metered dose 5 is exposed to ambient pressure. Rapid vaporization of the propellant causes the metered dose to be forced through the orifice, and into and through exit chamber 24. Device 10 is commonly used in combination with an actuator that facilitates inhalation of the resulting 10 aerosol by a patient.

A particularly preferred device of the invention is a metered dose configuration substantially as described above and illustrated in the Drawing. Other particular configurations, metered dose or 15 otherwise, are well known to those skilled in the art are suitable for use with the sealing members of this invention. For example the devices described in U.S. Pat. Nos. 4,819,834 (Thiel), 4,407,481 (Bolton), 3,052,382 (Gawthrop), 3,049,269 (Gawthrop), 2,980,301 20 (DeGorter), 2,968,427 (Meshberg), 2,892,576 (Ward), 2,886,217 (Thiel), and 2,721,010 (Meshberg) involve a valve stem, a diaphragm, and a casing member in the general relationship described herein. Generally any and all sealing members (such as diaphragms, seals, and 25 gaskets) that serve to minimize and/or prevent escape of components, especially propellant, from such assemblies can comprise the above described thermoplastic elastomer.

The devices and sealing members of the 30 invention can be used in connection with aerosol formulations involving propellants such as fluorotrichloromethane, dichlorodifluoromethane, and 1,2-dichlorotetrafluoroethane. However, this invention finds particular use with aerosol formulations 35 involving a propellant comprising HFC-134a or HFC-227. Any such formulation can be used. Pharmaceutical formulations are preferred.

Preferred pharmaceutical formulations generally comprise HFC-134a, HFC-227, or a mixture thereof in an amount effective to function as an aerosol propellant, a drug having local or systemic action and suitable for use by inhalation, and any optional formulation excipients. Exemplary drugs having local effect in the lung include bronchodilators such as albuterol, formoterol, pirbuterol, and salmeterol, and pharmaceutically acceptable salts and derivatives thereof, and steroids such as beclomethasone, fluticasone, and flunisolide, and pharmaceutically acceptable salts, derivatives, solvates, and clathrates thereof. Exemplary drugs having systemic effect include peptides such as insulin, calcitonin, interferons, colony stimulating factors, and growth factors.

The drug is present in the formulation in an amount sufficient to provide a predetermined number of therapeutically effective doses by inhalation, which can be easily determined by those skilled in the art considering the particular drug in the formulation. Optional excipients include cosolvents (e.g., ethanol, water) and surfactants (e.g., oleic acid, sorbitan esters, polyoxyethylenes, glycols) and others known to those skilled in the art.

A particularly preferred formulation comprises, by weight, 0.40% albuterol sulfate, 0.48% oleic acid, 14.26% absolute ethanol, and 84.86% HFC-134a. Another preferred formulation comprises, by weight, 0.337% beclomethasone dipropionate, 8.0% absolute ethanol, and 91.663% HFC-134a. Yet another preferred formulation comprises, by weight, 0.084% of beclomethasone dipropionate, 8.0% absolute ethanol, and 91.916% HFC-134a.

35

Diaphragm Preparation

Diaphragms of the invention can be prepared by conventional techniques known to those skilled in

the art, such as compression molding, extrusion, and injection molding. Those diaphragms exemplified herein were prepared according to the general methods set forth below:

5

Compression Molding

An amount of a selected elastomer sufficient to provide a compression molded sheet of the desired thickness is compression molded between appropriately spaced aluminum press plates in a CARVER™ Laboratory Press Model 2696 (Fred S. Carver, Inc., Menomonie Falls, Wisconsin) at elevated temperature (e.g., about 150°C) and pressure (e.g., 170 kPa) and for a time sufficient to form a molded sheet. The press is then cooled until the mold plates can be handled. The compression molded sheet is removed from the mold and hand punched with a die of the desired size to afford a diaphragm of the invention.

20 Extrusion

A sample of a selected elastomer is fed into the feed throat of a Haake RHEOCORT™ single-screw extruder fitted with a Haake RHEOMIX™ three-zone extruder head and equipped with a 1.9 cm (0.75 inch) diameter screw having a 3:1 pitch and a length to diameter ratio of 25:1. Appropriate screw speed and operating temperatures are selected according to the characteristics of the selected elastomer. The melt is extruded through a flat film die, fitted with a shim to provide the desired opening, and over a cooled chrome roller. The thickness of the resulting sheet is controlled by appropriate adjustment of screw speed and speed of the cooled roller. Diaphragms of the invention were hand cut from the sheet with a die of appropriate size.

Injection Molding

The selected elastomer is fed into the feed throat of a Van Dorn 75 ton injection molding machine equipped with a 5 ounce barrel. Operating conditions
5 are selected according to the characteristics of the selected elastomer. The melt is injected into a mold having cavity dimensions appropriate to provide the desired sealing member. Cooling and opening of the mold affords the sealing member.

10

Test Methods

Sealing members were tested as follows:

Leak Rate

15 Aerosol canister bodies (10 mL) are filled with an aerosol formulation and fitted with a metered dose valve substantially as described and illustrated above and comprising a diaphragm of a selected size and material. The valve is actuated several times in
20 order to assure its function. The mass of the filled device is measured. The filled device is allowed to stand in an upright position under the indicated conditions (30°C unless otherwise indicated) for a period of time, after which time mass is again
25 measured. The loss of mass over time is extrapolated to one year and reported in mg/year.

As used in the claims below the "Leak Rate Test Method" involves twenty-five independent determinations as described above, using HFC-134a as
30 the aerosol formulation and using a valve having a stainless steel valve stem with a 2.79 mm (0.110 inch) outside diameter and fitted with a diaphragm of the specified diaphragm material. The diaphragm is 0.89 mm
(0.035 inch) thick having an inside diameter of 2.41 mm
35 (0.095 inch), and having an outside diameter of 8.64 mm (0.34 inch).

Valve Delivery

The mass of a filled device is measured. The device is then inverted and actuated one time. Mass is again determined and the valve delivery is recorded as the difference.

The formulations used in the TABLES below in order to demonstrate the invention are as follows, wherein all parts and percentages are by weight:

Formulation	Albuterol Sulfate (%)	Beclomethasone Dipropionate (%)	Oleic Acid (%)	Ethanol (%)	HFC 134a (%)
A3	0.4	---	0.5	15	84.1
A5	1.2	---	0.5	15	83.3
B4	---	0.084	---	8.0	91.916
	Pirbuterol Acetate				HFC-227
P1	0.89	---	---	10.0	89.11
P2	0.5	---	---	---	99.5
	Albuterol Sulfate				HFC-227
A7	0.4	---	---		99.6

In the TABLES that follow, "ID" represents the inside diameter of the diaphragm; "ss" indicates a stainless steel valve stem; "pl" indicates a Delrin™ acetal resin valve stem; "N" indicates the number of 5 independent determinations used to evaluate the leak rate and valve delivery values. When two values are given, the first represents the number of determinations used to evaluate leak rate, the second represents the number of determinations used to 10 evaluate valve delivery. Leak rate and valve delivery are shown along with standard deviation. Unless otherwise indicated the outside diameter of the diaphragms is 8.64 mm (0.34 inch) and the thickness is 0.89 mm (0.035 inch).

15 For comparative purposes, diaphragms were prepared from "Buna" rubber and from butyl rubber, both materials being commonly used in commercially available metered dose inhalers. These diaphragms were tested with formulations as indicated in TABLES 1 and 2 below:

TABLE 1 - BUNA RUBBER

Formulation	ID (mm)	Stem	Time (Weeks)	N	Leak Rate (mg/yr)	Valve Delivery (mg/actuation)
A5	2.11	SS	0	20/12	---	50.56 ± 1.70
			4		386 ± 20	51.11 ± 1.33
			12		377 ± 14	53.82 ± 1.77
	2.24	SS	0	20/12	---	52.81 ± 1.64
			4		347 ± 49	52.97 ± 1.33
			12		392 ± 13	54.19 ± 2.70
	2.36	SS	0	20/12	---	53.05 ± 1.42
			4		345 ± 12	51.88 ± 3.76
			12		386 ± 13	54.14 ± 1.79
	2.49	SS	0	20/12	---	53.88 ± 1.80
			4		345 ± 16	53.78 ± 1.02
			12		388 ± 19	54.05 ± 1.14
2.11	Pl	0	20/12	---	50.62 ± 0.71	
		4		312 ± 18	49.00 ± 1.18	
		12		395 ± 160	51.02 ± 0.71	
2.24	Pl	0	20/12	---	53.32 ± 1.80	
		4		335 ± 12	52.53 ± 2.37	
		12		380 ± 13	53.71 ± 0.79	
2.36	Pl	0	20/12	---	51.22 ± 0.75	
		4		324 ± 19	49.94 ± 1.36	
		12		378 ± 22	51.00 ± 0.45	
2.49	Pl	0	20/12	---	51.27 ± 0.60	
		4		322 ± 12	50.57 ± 0.62	
		12		368 ± 13	51.13 ± 0.63	

TABLE 2 - BUTYL RUBBER

Formulation	ID (mm)	Stem	Time (Weeks)	N	Leak Rate (mg/yr)	Valve Delivery (mg/actuation)
A5	2.11	SS	0	20/12	---	58.86 ± 2.59
			4		174 ± 24	57.98 ± 2.04
			12		216 ± 16	58.13 ± 3.15
	2.24	SS	0	20/12	---	57.86 ± 2.49
			4		152 ± 9	58.02 ± 1.27
			12		197 ± 10	58.39 ± 3.32
	2.36	SS	0	20/12	---	59.12 ± 2.19
			4		151 ± 8	58.72 ± 3.35
			12		195 ± 9	58.92 ± 3.46
	2.49	SS	0	20/12	---	58.74 ± 2.54
			4		168 ± 28	58.02 ± 2.14
			12		208 ± 30	60.59 ± 4.11
2.11	pl	0	20/12	---	55.92 ± 0.59	
		4		159 ± 12	54.45 ± 1.73	
		12		247 ± 160	54.62 ± 1.04	
2.24	pl	0	20/12	---	56.31 ± 0.28	
		4		169 ± 25	54.50 ± 3.10	
		12		218 ± 22	54.37 ± 2.59	
2.36	pl	0	20/12	---	56.20 ± 0.73	
		4		161 ± 14	54.32 ± 1.58	
		12		211 ± 15	55.04 ± 0.78	
2.49	pl	0	20/12	---	56.67 ± 1.11	
		4		156 ± 11	55.16 ± 0.43	
		12		204 ± 11	55.24 ± 0.78	

The results in TABLES 1 and 2 show that, when used with the indicated formulations, "Buna" diaphragms generally exhibit leak rates higher than 300 mg/yr with generally acceptable valve delivery variability. The 5 results also show that the butyl rubber diaphragms exhibit acceptable leak rates when used with the indicated formulations but valve delivery variability is not acceptable.

Compression molded, hand cut diaphragms of 10 the invention were prepared from the materials set forth in TABLES 3-8 below and tested with the indicated formulations. The absence of an entry indicates that no measurement was made.

TABLE 3
C-FLEX™ COPOLYMER R70-001-000

Formulation	Stem	ID (mm)	Time (Weeks)	Leak Rate (mg/YR) ± SD	Valve Delivery (mg/actuation) ± SD
A3	ss	2.03	6	390 ± 28	54.01 ± 1.25
	ss	2.16	6	410 ± 41	55.62 ± 1.70
	ss	2.29	6	426 ± 35	55.42 ± 1.68
	ss	2.41	6	417 ± 26	58.04 ± 5.59
	ss	2.54	6	439 ± 13	61.37 ± 6.29
	ss	2.67	6	449 ± 48	66.41 ± 8.89
	pl	2.03	6	383 ± 30	49.98 ± 0.78
	pl	2.16	6	387 ± 19	50.03 ± 0.78
	pl	2.29	6	411 ± 33	50.28 ± 0.71
	pl	2.41	6	399 ± 22	51.06 ± 0.71
	pl	2.54	6	445 ± 42	50.59 ± 0.55
	pl	2.67	6	398 ± 21	50.55 ± 0.69

TABLE 3 - Continued

Formulation	Stem	ID (mm)	Time (Weeks)	Leak Rate (mg/yr) ± SD	Valve Delivery (mg/actuation) ± SD
B4	SS	2.03	6	305 ± 26	58.08 ± 0.47
	SS	2.16	6	278 ± 15	58.46 ± 1.69
	SS	2.29	6	297 ± 28	58.97 ± 1.33
	SS	2.41	6	299 ± 16	60.18 ± 1.65
	SS	2.54	6	288 ± 14	60.31 ± 3.43
	SS	2.67	6	293 ± 12	66.28 ± 4.17
	pl	2.03	6	282 ± 15	53.60 ± 0.87
	pl	2.16	6	275 ± 15	53.79 ± 0.87
	pl	2.29	6	288 ± 17	53.72 ± 1.58
P1	pl	2.41	6	280 ± 16	53.73 ± 0.63
	pl	2.54	6	272 ± 21	54.47 ± 1.63
	pl	2.67	6	271 ± 17	54.74 ± 0.51
P2	SS	2.29	12	46 ± 8	64.18 ± 0.98
A7	SS	2.29	6	25 ± 3	74.14 ± 1.88
	SS	2.29	6	42 ± 19	75.10 ± 1.09

TABLE 4
C-FLEX™ COPOLYMER R70-026

Formulation	Stem	ID (mm)	Time (Weeks)	Leak Rate (mg/Yr) ± SD	Valve Delivery (mg/actuation) ± SD
A3	SS	2.03	6	468 ± 24	59.49 ± 0.95
	SS	2.16	6	606 ± 473	59.72 ± 0.75
	SS	2.29	6	432 ± 33	59.76 ± 0.83
	SS	2.41	6	412 ± 32	59.36 ± 0.92
	SS	2.54	6	427 ± 30	59.36 ± 1.02
	SS	2.67	6	430 ± 25	58.10 ± 2.84
	p1	2.03	6	455 ± 60	56.50 ± 1.34
	p1	2.16	6	437 ± 29	57.02 ± 0.77
	p1	2.29	6	411 ± 26	57.58 ± 0.58
	p1	2.41	6	437 ± 25	57.44 ± 0.93
	p1	2.54	6	411 ± 36	57.48 ± 1.36
	p1	2.67	6	443 ± 47	57.87 ± 0.84

TABLE 4 - Continued

Formulation	Stem	ID (mm)	Time (Weeks)	Leak Rate (mg/yr) ± SD	Valve Delivery (mg/actuation) ± SD
B4	SS	2.03	6	290 ± 18	63.90 ± 0.59
	SS	2.16	6	310 ± 25	63.95 ± 0.89
	SS	2.29	6	295 ± 15	63.88 ± 0.86
	SS	2.41	6	332 ± 67	63.59 ± 0.61
	SS	2.54	6	316 ± 29	64.01 ± 0.65
	SS	2.67	6	310 ± 14	64.24 ± 0.81
	p1	2.03	6	303 ± 26	61.08 ± 0.63
	p1	2.16	6	314 ± 27	62.09 ± 0.36
	p1	2.29	6	292 ± 16	62.65 ± 1.78
P1	p1	2.41	6	302 ± 20	63.00 ± 1.39
	p1	2.54	6	303 ± 29	66.26 ± 0.98
	p1	2.67	6	334 ± 84	63.94 ± 1.21
P1	SS	2.29	12	51 ± 11	69.24 ± 0.79
P2	SS	2.29	6	26 ± 2	76.36 ± 0.43
A7	SS	2.29	6	36 ± 6	77.74 ± 1.10

TABLE 5
C-FLEX™ COPOLYMER R70-041

Formulation	Stem	ID (mm)	Time (Weeks)	Leak Rate (mg/yr) ± SD	Valve Delivery (mg/actuation) ± SD
A3	SS	2.03	6	651 ± 37	56.83 ± 2.47
	SS	2.16	6	702 ± 65	56.87 ± 0.69
	SS	2.29	6	693 ± 74	56.39 ± 1.22
	SS	2.41	6	682 ± 53	56.44 ± 1.46
	SS	2.54	6	719 ± 44	56.80 ± 4.42
	SS	2.67	6	706 ± 53	58.75 ± 4.02
	pl	2.03	6	648 ± 35	52.27 ± 0.86
	pl	2.16	6	689 ± 50	52.56 ± 1.15
	pl	2.29	6	694 ± 35	52.66 ± 0.99
	pl	2.41	6	649 ± 50	52.88 ± 2.07
	pl	2.54	6	660 ± 42	52.23 ± 0.75
	pl	2.67	6	707 ± 45	-----

TABLE 5 - Continued

Formulation	Stem	ID (mm)	Time (Weeks)	Leak Rate (mg/yr) ± SD	Valve Delivery (mg/actuation) ± SD
B4	SS	2.03	6	450 ± 28	60.99 ± 1.93
	SS	2.16	6	478 ± 36	60.57 ± 1.39
	SS	2.29	6	437 ± 21	60.86 ± 0.69
	SS	2.41	6	450 ± 25	60.55 ± 1.09
	SS	2.54	6	434 ± 21	61.71 ± 1.69
	SS	2.67	6	439 ± 30	62.04 ± 3.47
	pl	2.03	6	449 ± 35	56.40 ± 1.25
P1	pl	2.16	6	453 ± 29	56.93 ± 1.25
	pl	2.29	6	417 ± 13	56.67 ± 1.42
	pl	2.41	6	433 ± 15	56.72 ± 0.94
	pl	2.54	6	435 ± 21	57.99 ± 2.65
	pl	2.67	6	441 ± 18	57.58 ± 1.48
	SS	2.29	12	34 ± 10	63.18 ± 1.65
	SS	2.29	6	19 ± 2	72.10 ± 2.54
A7	SS	2.29	6	38 ± 16	72.32 ± 0.88

TABLE 6
C-FLEX™ COPOLYMER R70-051

Formulation	Stem	ID (mm)	Time (Weeks)	Leak Rate (mg/Yr) ± SD	Valve Delivery (mg/actuation) ± SD
A3	SS	2.03	6	408 ± 21	54.99 ± 1.41
	SS	2.16	6	403 ± 29	56.59 ± 1.44
	SS	2.29	6	433 ± 32	57.33 ± 0.75
	SS	2.41	6	421 ± 50	56.65 ± 1.67
	SS	2.54	6	403 ± 22	56.85 ± 0.61
	SS	2.67	6	438 ± 38	57.27 ± 1.02
	pl	2.03	6	382 ± 22	53.49 ± 1.15
	pl	2.16	6	399 ± 20	53.57 ± 1.16
	pl	2.29	6	416 ± 31	54.28 ± 0.58
	pl	2.41	6	466 ± 90	54.44 ± 0.97
	pl	2.54	6	427 ± 34	53.95 ± 0.63
	pl	2.67	6	395 ± 20	54.69 ± 1.01

TABLE 6 - Continued

Formulation	Stem	ID (mm)	Time (Weeks)	Leak Rate (mg/yr) ± SD	Valve Delivery (mg/actuation) ± SD
B4	SS	2.03	6	285 ± 20	61.12 ± 0.80
	SS	2.16	6	282 ± 13	62.06 ± 2.29
	SS	2.29	6	308 ± 49	61.12 ± 0.80
	SS	2.41	6	273 ± 14	61.15 ± 0.66
	SS	2.54	6	287 ± 17	61.84 ± 1.47
	SS	2.67	6	288 ± 16	61.89 ± 1.55
	p1	2.03	6	282 ± 20	57.79 ± 0.86
	p1	2.16	6	286 ± 11	58.05 ± 0.66
	p1	2.29	6	289 ± 11	58.38 ± 0.67
	p1	2.41	6	272 ± 16	58.27 ± 0.75
	p1	2.54	6	273 ± 19	59.33 ± 1.99
	p1	2.67	6	282 ± 7	59.63 ± 3.35
P1	SS	2.29	12	46 ± 12	65.80 ± 0.82
P2	SS	2.29	6	20 ± 3	73.74 ± 0.71
A7	SS	2.29	6	30 ± 8	74.00 ± 0.85

TABLE 7
C-FLEX™ COPOLYMER R70-085

Formulation	Stem	ID (mm)	Time (Weeks)	Leak Rate (mg/yr) ± SD	Valve Delivery (mg/actuation) ± SD
A3	SS	2.03	6	360 ± 20	50.19 ± 8.72
	SS	2.16	6	403 ± 20	53.57 ± 1.68
	SS	2.29	6	376 ± 20	54.23 ± 0.89
	SS	2.41	6	430 ± 60	53.31 ± 0.88
	SS	2.54	6	501 ± 47	54.73 ± 1.04
	SS	2.67	6	460 ± 42	54.54 ± 2.01
	p1	2.03	6	346 ± 18	49.02 ± 1.17
	p1	2.16	6	379 ± 21	50.02 ± 0.89
	p1	2.29	6	383 ± 56	49.41 ± 1.00
	p1	2.41	6	352 ± 29	50.11 ± 0.52
	p1	2.54	6	493 ± 33	49.59 ± 1.05
	p1	2.67	6	505 ± 42	50.21 ± 1.01

TABLE 7 - continued

Formulation	Stem	ID (mm)	Time (Weeks)	Leak Rate (mg/yr) \pm SD	Valve Delivery (mg/actuation) \pm SD
B4	SS	2.03	6	280 \pm 16	59.12 \pm 3.26
	SS	2.16	6	261 \pm 17	59.07 \pm 0.85
	SS	2.29	6	276 \pm 18	58.54 \pm 0.84
	SS	2.41	6	277 \pm 21	59.31 \pm 0.98
	SS	2.54	6	243 \pm 17	62.18 \pm 2.60
	SS	2.67	6	279 \pm 75	60.61 \pm 2.76
	pl	2.03	6	274 \pm 24	52.63 \pm 0.74
	pl	2.16	6	272 \pm 20	53.31 \pm 0.95
	pl	2.29	6	262 \pm 13	52.10 \pm 0.65
	pl	2.41	6	269 \pm 12	54.03 \pm 1.19
	pl	2.54	6	252 \pm 17	54.82 \pm 2.81
	pl	2.67	6	252 \pm 21	53.22 \pm 1.08

TABLE 7 - continued

Formulation	Stem	ID (mm)	Time (Weeks)	Leak Rate (mg/Yr) ± SD	Valve Delivery (mg/actuation) ± SD
P1	SS	2.29	12	36 ± 8	63.00 ± 1.87
P2	SS	2.29	6	15 ± 2	70.48 ± 1.00
A7	SS	2.29	6	27 ± 7	73.26 ± 1.23

TABLE 8
C-FLEX™ COPOLYMER R70-003-000

Formulation	Stem	ID (mm)	Time (Weeks)	Leak Rate (mg/yr) ± SD	Valve Delivery (mg/actuation) ± SD
B4	SS	2.03	6	393 ± 25	59.94 ± 1.16
	SS	2.16	6	387 ± 15	60.36 ± 1.07
	SS	2.29	6	405 ± 25	60.75 ± 0.84
	SS	2.41	6	392 ± 23	62.62 ± 3.17
	SS	2.54	6	380 ± 23	62.49 ± 1.60
	SS	2.67	6	393 ± 29	64.45 ± 4.28
	pl	2.03	6	417 ± 27	56.92 ± 0.79
	pl	2.16	6	394 ± 39	56.84 ± 0.51
	pl	2.29	6	374 ± 23	57.42 ± 1.46
	pl	2.41	6	391 ± 17	57.41 ± 1.15
	pl	2.54	6	396 ± 32	57.19 ± 0.82
	pl	2.67	6	395 ± 20	58.32 ± 0.53

TABLE 8 - continued

Formulation	Stem	ID (mm)	Time (Weeks)	Leak Rate (mg/YR) ± SD	Valve Delivery (mg/actuation) ± SD
A3	SS	2.03	6		55.22 ± 0.83
	SS	2.16	6		55.48 ± 0.66
	SS	2.29	6		55.29 ± 0.85
	SS	2.41	6		55.57 ± 0.64
	SS	2.54	6		55.39 ± 0.67
	SS	2.67	6		55.46 ± 1.69
	pl	2.03	6		54.21 ± 0.46
	pl	2.16	6		54.38 ± 0.44
	pl	2.29	6		55.24 ± 3.12
	pl	2.41	6		53.74 ± 0.93
	pl	2.54	6		54.10 ± 1.62
	pl	2.67	6		54.04 ± 1.28

TABLE 8 - continued

Formulation	Stem	ID (mm)	Time (Weeks)	Leak Rate (mg/yr) ± SD	Valve Delivery (mg/actuation) ± SD
P1	SS	2.29	12	54 ± 17	65.73 ± 1.06
P2	SS	2.29	6	26 ± 3	74.80 ± 1.29
A7	SS	2.29	6	54 ± 27	75.60 ± 1.15

The results in TABLES 3-8 above show that the indicated materials have acceptable leak rate and valve delivery variability when used as diaphragm materials in metered dose inhalers containing formulations with 5 HFC-134a or HFC-227 as the propellant.

The Claimed Invention Is:

1. A device for delivering an aerosol, comprising: a valve stem, a diaphragm having walls
5 defining a diaphragm aperture, and a casing member having walls defining a casing aperture, wherein the valve stem passes through the diaphragm aperture and the casing aperture and is in slidable sealing engagement with the diaphragm aperture, and wherein the
10 diaphragm is in sealing engagement with the casing member, the diaphragm material comprising a thermoplastic elastomer comprising a styrene-ethylene/butylene-styrene block copolymer.
- 15 2. A device according to Claim 1, wherein the thermoplastic elastomer further comprises a polyolefin.
3. A device according to Claim 2 wherein the
20 polyolefin is polypropylene.
4. A device according to Claim 2, wherein the thermoplastic elastomer further comprises a
siloxane.
- 25 5. A device according to Claim 1, wherein the diaphragm material exhibits a leak rate of less than about 500 mg/year when tested according to the Leak Rate Test Method.
- 30 6. A device according to Claim 1, further comprising: a tank seal having walls defining a tank seal aperture, and a metering tank of a predetermined volume and having an inlet end, an inlet aperture, and
35 an outlet end, wherein the outlet end is in sealing engagement with the diaphragm, the valve stem passes through the inlet aperture and the tank seal aperture and is in slidable engagement with the tank seal

aperture, and the tank seal is in sealing engagement with the inlet end of the metering tank, and wherein the valve stem is movable between an extended closed position, in which the inlet end of the metering tank
5 is open and the outlet end is closed, and a compressed open position in which the inlet end of the metering tank is substantially sealed and the outlet end is open to the ambient atmosphere.

10 7. A device according to Claim 6, wherein the casing member defines a formulation chamber.

 8. A device according to Claim 7, wherein the formulation chamber contains an aerosol formulation
15 comprising 1,1,1,2-tetrafluoroethane, 1,1,1,2,3,3,3-heptafluoropropane, or a mixture thereof, in an amount effective to function as a propellant.

 9. A device according to Claim 8, wherein
20 the formulation is a pharmaceutical formulation comprising 1,1,1,2-tetrafluoroethane, 1,1,1,2,3,3,3-heptafluoropropane, or a mixture thereof, in an amount effective to function as an aerosol propellant, and a drug in an amount sufficient to provide a predetermined
25 number of therapeutically effective doses for inhalation.

 10. A device according to Claim 9, wherein the formulation further comprises ethanol.

30

 11. A device according to Claim 10, wherein the formulation further comprises a surfactant.

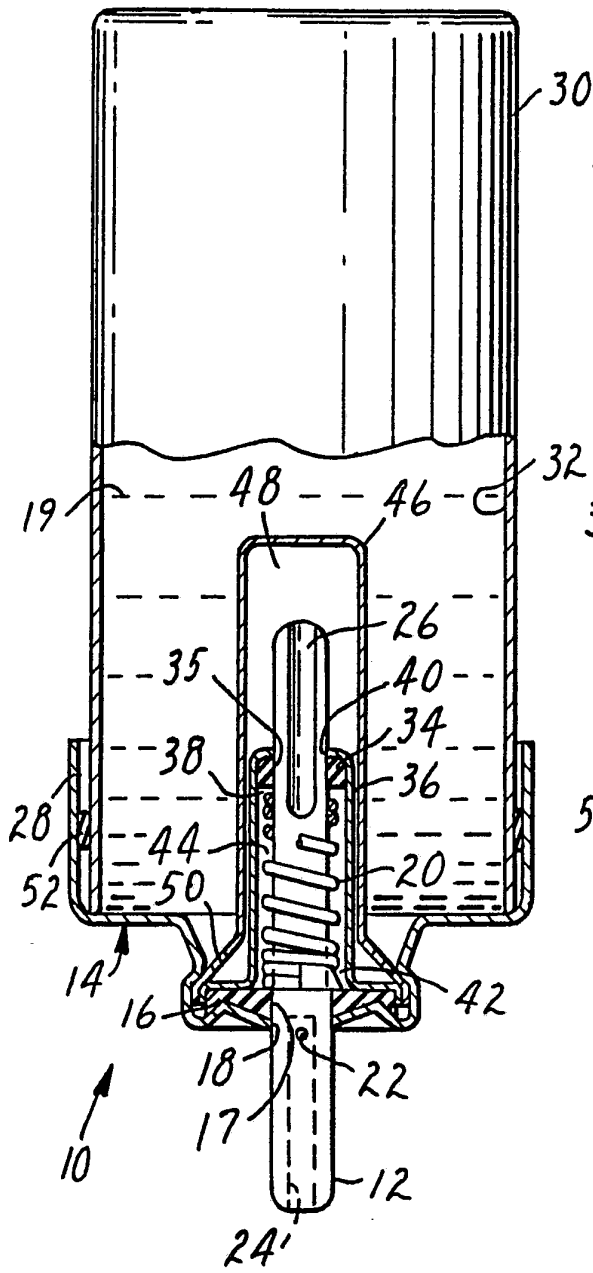

FIG. 1

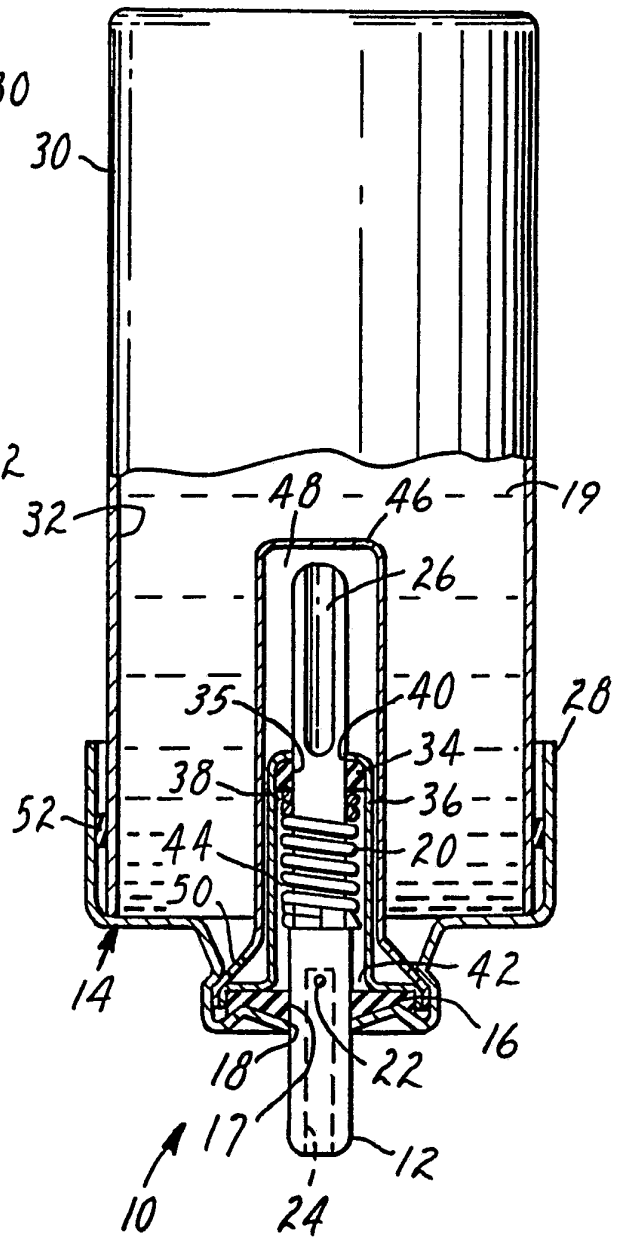

FIG. 2

INTERNATIONAL SEARCH REPORT

International Application No

PCT/US 93/04328

I. CLASSIFICATION OF SUBJECT MATTER (if several classification symbols apply, indicate all) ⁶		
According to International Patent Classification (IPC) or to both National Classification and IPC Int.Cl. 5 B65D83/54		
II. FIELDS SEARCHED		
Minimum Documentation Searched ⁷		
Classification System	Classification Symbols	
Int.Cl. 5	B65D	
Documentation Searched other than Minimum Documentation to the Extent that such Documents are Included in the Fields Searched ⁸		
III. DOCUMENTS CONSIDERED TO BE RELEVANT⁹		
Category ¹⁰	Citation of Document, ¹¹ with indication, where appropriate, of the relevant passages ¹²	Relevant to Claim No. ¹³
Y	DATABASE WPIL Week 9221, Derwent Publications Ltd., London, GB; AN 92172534 & JP,A,4 110 381 (SEKISUI CHEM IND CO LTD) 10 April 1992 see abstract ---	1-11
Y	GB,A,2 077 229 (NEOTECHNIC ENG. LTD) 16 December 1981 see claim 1; figure 1 & US,A,4 407 481 (NEOTECHNIC) ---	1-11
Y	WO,A,9 111 495 (BOEHRINGER) 8 August 1991 see page 2, line 1 - page 4, line 2 ---	8-11
A	US,A,3 702 310 (SIMONS) 7 November 1972 ---	-/--
<p>¹⁰ Special categories of cited documents:</p> <ul style="list-style-type: none"> "A" document defining the general state of the art which is not considered to be of particular relevance "E" earlier document but published on or after the international filing date "L" document which may throw doubts on priority claim(s) or which is cited to establish the publication date of another citation or other special reason (as specified) "O" document referring to an oral disclosure, use, exhibition or other means "P" document published prior to the international filing date but later than the priority date claimed "T" later document published after the international filing date or priority date and not in conflict with the application but cited to understand the principle or theory underlying the invention "X" document of particular relevance; the claimed invention cannot be considered novel or cannot be considered to involve an inventive step "Y" document of particular relevance; the claimed invention cannot be considered to involve an inventive step when the document is combined with one or more other such documents, such combination being obvious to a person skilled in the art. "&" document member of the same patent family 		
IV. CERTIFICATION		
Date of the Actual Completion of the International Search	Date of Mailing of this International Search Report	
06 SEPTEMBER 1993	23. 09. 93	
International Searching Authority	Signature of Authorized Officer	
EUROPEAN PATENT OFFICE	MARTENS L.G.R.	

III. DOCUMENTS CONSIDERED TO BE RELEVANT (CONTINUED FROM THE SECOND SHEET)		
Category °	Citation of Document, with indication, where appropriate, of the relevant passages	Relevant to Claim No.
A	FR,A,2 532 714 (AEROSOL INVENTIONS AND DEVELOPMENT SA) 9 March 1984 ----	
A	DE,B,1 700 092 (RIKER LAB) 15 January 1970 & US,A,2 886 217 (THIEL) ----	
P,A	WO,A,9 211 190 (MINNESOTA MINING AND MANUFACTURING CY) 9 July 1992 see page 4, line 30 - page 11, line 28; figures 1,2 -----	1-11

**ANNEX TO THE INTERNATIONAL SEARCH REPORT
ON INTERNATIONAL PATENT APPLICATION NO.**

US 9304328
SA 74115

This annex lists the patent family members relating to the patent documents cited in the above-mentioned international search report. The members are as contained in the European Patent Office EDP file on The European Patent Office is in no way liable for these particulars which are merely given for the purpose of information. 06/09/93

Patent document cited in search report	Publication date	Patent family member(s)	Publication date
GB-A-2077229	16-12-81	BE-A- 888819	28-08-81
		US-A- 4407481	04-10-83
WO-A-9111495	08-08-91	DE-A- 4003272	08-08-91
		AU-A- 7211391	21-08-91
		CA-A- 2075058	04-08-91
		EP-A- 0514415	25-11-92
		JP-T- 5504160	01-07-93
US-A-3702310	07-11-72	DE-A- 2055122	22-06-72
		FR-A- 2112650	23-07-72
		GB-A- 1309838	14-03-73
FR-A-2532714	09-03-84	DE-A- 3332167	08-03-84
DE-B-1700092	15-01-70	GB-A- 864694	
		US-A- 2886217	
WO-A-9211190	09-07-92	AU-A- 9167991	22-07-92