



(11) **EP 2 256 281 B1**

(12) **EUROPEAN PATENT SPECIFICATION**

(45) Date of publication and mention of the grant of the patent:
31.03.2021 Bulletin 2021/13

(51) Int Cl.:
E06B 7/02 (2006.01)

(21) Application number: **10397508.2**

(22) Date of filing: **24.05.2010**

(54) **AIR GUIDE**

LUFTFÜHRUNG

GUIDAGE D'AIR

(84) Designated Contracting States:
AL AT BE BG CH CY CZ DE DK EE ES FI FR GB GR HR HU IE IS IT LI LT LU LV MC MK MT NL NO PL PT RO SE SI SK SM TR

(30) Priority: **29.05.2009 FI 20090210 U**

(43) Date of publication of application:
01.12.2010 Bulletin 2010/48

(73) Proprietor: **Air Termico Oy**
05460 Hyvinkää (FI)

(72) Inventor: **TARPIO, Tapio**
11710 Riihimäki (FI)

(74) Representative: **Berggren Oy, Tampere**
Visiokatu 1
33720 Tampere (FI)

(56) References cited:
WO-A1-2006/042550 DE-A1- 2 404 836
DE-U1- 29 719 751 GB-A- 2 250 088

EP 2 256 281 B1

Note: Within nine months of the publication of the mention of the grant of the European patent in the European Patent Bulletin, any person may give notice to the European Patent Office of opposition to that patent, in accordance with the Implementing Regulations. Notice of opposition shall not be deemed to have been filed until the opposition fee has been paid. (Art. 99(1) European Patent Convention).

Description

Field of the invention

[0001] The present invention relates to an air guide according to the appended claim 1 as well as a window according to the appended claim 3.

Background of the invention

[0002] For implementing the ventilation of rooms, gravitational ventilation systems, exhaust air ventilation systems, as well as supply air/exhaust air ventilation systems are known. In the gravitational ventilation system, the ventilation of rooms is based on pressure differences and temperature differences, wherein warm indoor air tends to rise upwards and exits the room via an exhaust valve. This will result in an underpressure, by means of which replacement air is sucked from the outside of the room, typically from atmospheric air, via a replacement air valve into the room. The exhaust air ventilation system comprises a mechanical vent device which removes air mechanically from a room and causes an underpressure in the room. Thus, the underpressure causes a flow of replacement air via the replacement air valve into the room. The supply air/exhaust air system also comprises a mechanical vent arrangement for removing spent air from a room, and an inlet air duct system, through which replacement air is introduced into the room.

[0003] Of the above-mentioned ventilation systems, both the gravitational system and the exhaust air ventilation system apply a replacement air valve, via which replacement air is introduced into the room. Such a replacement air valve is typically provided in connection with a window, for example in the built-in frame above the window or in the casement frame.

[0004] With more stringent energy-saving standards, so-called supply air windows have been developed for the purpose of warming the replacement air before it is introduced into a room in a situation in which the temperature of outdoor air is lower than the indoor temperature. The supply air window utilizes thermal energy conducted from the room through the window, as well as thermal energy emitted through the window. Thus, this thermal energy warms the replacement air before it is introduced into the room. This is typically achieved with a replacement air valve comprising a duct system to guide replacement air into a so-called interspace in the window. A window normally comprises two or more panes, wherein said interspace is formed in the space left between two panes in the window. If the window comprises three panes, the window thus comprises two interspaces, of which the first one is between the outermost pane (the pane on the outdoor side) and the middle pane, and the second one is between the middle pane and the innermost pane (the pane on the indoor side), respectively. In such a case, the replacement air can be introduced into either the first interspace or the second interspace or even both, for

example first into the first interspace and from there into the second interspace.

[0005] DE29719751 U1 discloses a ventilation device for a window. The ventilation element comprises cylindrical, tapered air channels for leading replacement air into a room. The air channels have balls which are able to rotate in the air channels. If the speed of the air flow in the air channels increases e.g. due to a strong wind, the balls rotate towards the narrower end of the air channels wherein they reduce, if not totally suspend, air flowing into the room. In other words, the balls are adapted to operate as air flow restricting elements.

[0006] The ventilation device also comprises an air guide installed on the surface of the casement of the window. The air guide has a louver via which the replacement air can flow into the room, and a wall which turns the air flow downwards. The air guide has a protrusion which can be used to attach the air guide to the ventilation device above the casement of the window.

[0007] In supply air windows of the above-described kind, two inlets are needed, of which the first inlet conveys the replacement air from the outside into the interspace of the window, and the second inlet conveys the air warmed in the interspace of the window further via the replacement air valve into the room. The first inlet is normally provided either in the casement or, for example, in the lower profile of the built-in frame of the window. Providing such an inlet requires drilling, milling and/or other work stages, so that an air flow duct is formed from outdoor air into the window interspace.

[0008] DE2404836 discloses a frame, especially for double-glazed windows. The frame comprises metal frame beams formed from bevelled or corresponding profiled metal strip. At least in the middle region is embedded a hard ash layer, such as polyurethane or the like, wherein in the coating area of the thermally conductive cross-section of the metal strips is kept to a minimum through holes or through complete transection.

Brief summary of the invention

[0009] It is an aim of the present invention to provide an air guide arrangement, in which the first inlet does not need to be manufactured separately, but it is implemented by utilizing an air gap formed in the window during its manufacture. To put it more precisely, the air guide according to the present invention is primarily characterized in what will be presented in the characterizing part of the appended claim 1. The window according to the present invention is primarily characterized in what will be presented in the characterizing part of the appended claim 3.

[0010] The present invention shows remarkable advantages over solutions of prior art. When the air guide according to the invention is applied, there is no need to provide the window with a separate inlet for introducing replacement air from the outside into the window interspace, but this can be implemented by means of a gap left between the casement and the built-in frame of the

window. Thus, the air guide and this gap together form a first inlet for introducing replacement air from outdoors to the window interspace in such a way that the replacement air from outdoors tends to flow downwards in the window interspace, until the replacement air becomes warmer and starts to flow upwards in the window interspace towards a second inlet, from which the replacement air is conveyed to the duct system of a replacement air valve and further into a room. By means of the invention, the supply of replacement air can be implemented by fewer work stages than by using solutions of prior art.

Description of the drawings

[0011] In the following, the present invention will be described in more detail with reference to the appended drawings, in which

- Fig. 1 shows an air guide according to an advantageous embodiment of the invention in a perspective view,
- Fig. 2 shows the air guide of Fig. 1 in a reduced cross-sectional view,
- Fig. 3 shows a window according to an embodiment of the invention in a cross-sectional view,
- Fig. 4 shows an example of a sheet preform used for making the air guide shown in Fig. 1, and
- Fig. 5 shows an air guide according to another advantageous embodiment of the invention in a reduced cross-sectional view.

Detailed description of the invention

[0012] In the following, we shall discuss the air guide 1 of Fig. 1 in more detail with reference to Figs. 1 and 2. The air guide 1 comprises a first wall 2 which is used for fastening the air guide in connection with a window 3 (Fig. 3) in a way to be presented below. The air guide 1 further comprises a second wall 4 and a flow louver 5 which form a first inlet 6 for introducing air into a window interspace 10a, 10b. The flow louver 5 is formed, for example, by punching or providing openings in another way in that part of the air guide 1 which is between the first wall 2 and the second wall 4. The openings can be made in the sheet preform 21, for example, by die cutting. An example of such a sheet preform 21 and the manufacture of an air guide from the sheet preform 21 will be described below in this description.

[0013] The air guide 1 further comprises a guide wall 8 for the air flow, tending to guide the air flowing through the flow louver 5 towards the surface of the outer pane 9a of the window and further downwards in the window interspace. This will be described in more detail below in this description. It should be mentioned that the guide

wall 8 for the air flow can be formed as a solid wall with said second wall 4. If necessary, the flow louver 5 can be provided with one or more filters 24 for filtering out impurities, such as dust particles etc., possibly entrained in the replacement air. In this way, at least part of the impurities are trapped in the filter and do not find their way into the room.

[0014] Figure 3 shows an embodiment of a window 3 provided with an air guide 1 according to the invention. In this advantageous example, the window 3 comprises three panes 9a, 9b, 9c, wherein a first interspace 10a is formed between the first pane 9a and the second pane 9b, and a second interspace 10b is formed between the second pane 9b and the third pane 9c, respectively. The window 3 also comprises a first casement 11a and a second casement 11b, but it is obvious that the number of casements 11a, 11b may also be only one or greater than two. The casements 11a, 11b are preferably formed to encircle the panes 9a, 9b, 9c at each edge; in other words, the casements 11a, 11b preferably comprise four casement elements, one at each edge of the pane. Each pane 9a, 9b, 9c is partly embedded in the respective casement 11a, 11b and, if necessary, the joint between the casement 11a, 11b and the pane can be sealed with, for example, silicone.

[0015] Finally, the window 3 comprises a built-in frame 12, to which the casements 11a, 11b can be attached, for example, by hinges (not shown). The built-in frame 12 is also arranged to encircle the casements of the window, wherein the frame preferably consists of four frame elements.

[0016] The window 3 can be fixed to the wall 13 of a room by any suitable fastening means (not shown). Between the frame 12 and the wall 13, a small gap is typically left, whose size is in the order of a few millimetres. This gap, such as, for example, the gap formed between the frame element above the window and the wall 13, can be used to accommodate, for example, a replacement air valve 14 to introduce replacement air into the room.

[0017] From the cross-sectional view of Fig. 3, it can be seen that there is a small gap 15 between the first casement 11a and the built-in frame 12 of the window, connected to outdoor air. At the stage of manufacturing the window, this gap may have been equipped with a sealing to prevent an air flow through this gap. In the present invention, this gap 15 is utilized by fastening an air guide 1 preferably to the first casement 11a of the window in such a way that the air guide 1 is in the first interspace 10a and that the first inlet 6 of the air guide 1 is in a flow connection with this gap 15. Thus, replacement air from the outside can flow through the gap 15 and the first inlet 6 into the first interspace 10a. The air flow guide wall 8 of the air guide guides the flow of replacement air towards the inner surface of the outermost pane 9a of the first interspace 10a. This flow is illustrated by arrow F1 in Fig. 3. In a situation, in which the replacement air is colder than the indoor temperature, the replacement air flows downwards; in other words, it, in a

way, runs on the inner surface of the first pane 9a. From the room, warm air is emitted and conducted through the panes into the interspace, wherein replacement air from outdoors also becomes slightly warmer when it flows downwards. At least partly for this reason, the air flow starts to turn upwards towards the upper end of the first interspace 10a. At the upper edge of the window, an air flow duct 16 is provided in the built-in frame to let the replacement air that has become warmer in the first interspace 10a flow into the replacement air valve 14. This flow is illustrated by an arrow F2 in Fig. 3.

[0018] The upper edge of the second wall 4 of the air guide 1 can further be provided with a sealing 20 to prevent the flow of replacement air from between the second wall 4 and the built-in frame 12 directly into the air flow duct 16. Such a by-pass flow might diminish the effect of warming the replacement air.

[0019] Preferably, the replacement air valve 14 has two positions which may be called, for example, the summer position and the winter position. In the summer position, the above-mentioned air flow duct 16 is closed, preventing the flow of replacement air through the window interspace into the replacement air valve. This is advantageous, among other things, for the reason that in a situation in which outdoor air is warmer than the target temperature of indoor air, the warming effect of the window interspace is not desirable. In the summer position, the replacement air is guided to pass directly from the inlet 17 to the duct system of the replacement air valve and further into the room.

[0020] The window 3 can also be provided with a protective plate 18 which, particularly above the window, reduces the entry of rain water through the gap 15 between the first casement 11a, that is, the casement of the outermost pane, and the built-in frame into the interspace 10a. A small clearance is left between this protective plate and the first casement 11a along at least part of the length of the first casement 11a, to enable the flow of replacement air into the first interspace 10a.

[0021] In the advantageous embodiment of the window shown in Fig. 3, this protective plate 18 also extends to the built-in frame advantageously so that an air gap 19 is also left between the protective plate 18 and the built-in frame 12, allowing replacement air to flow into the inlet 17 of the replacement air valve 14, when the replacement air valve 14 is in the summer position. This flow is illustrated by an arrow F3 in Fig. 3.

[0022] Figure 4 shows an advantageous example of a sheet preform 21, of which the air guide 1 according to the invention can be made. The sheet preform 21 is shaped so that by bending it at the locations marked with broken lines, the desired shape of the air guide 1 can be achieved. In the sheet preform of Fig. 4, four such bending lines 22a-22d are shown. The area between the first bending line 22a and the second bending line 22b is provided with a set of openings, wherein this part of the sheet preform constitutes the flow louver 5 of the air guide 1. The sheet preform 21 can also be bent at the third bend-

ing line 22c to form the air flow guide wall 8. This air flow guide wall 8 can be provided with yet another deflection at the location indicated by the fourth bending line 22d. However, a relatively small deflection is made in this location, to prevent the flow resistance from growing excessively high. On the other hand, the deflection serves the function of directing the replacement air flow diagonally towards the surface of the first pane 9a to make the flow as close to this surface as possible and to enable the flow of replacement air down to the lower part of the first window interspace 10a before the flow turns towards the air flow duct 16 in the upper part of the first interspace 10a. It should still be mentioned in this context that the air guide 1 can also be made of two or more parts, for example in such a way that the air flow guide wall 8 is a separate sheet that is attached to the second wall 2 by means of a suitable fastening method. In this alternative (Fig. 5), the sheet preform can be thought to be cut at the third bending line into two separate parts, wherein one part forms the first wall 2, the second wall 4 and the flow louver 5, and the other part forms the air flow guide wall 8.

[0023] According to the invention, at least one of the bending angles corresponding to the first bending line 22a and second bending line 22b is a few degrees greater than 90 degrees while the other is in the order of 90 degrees, wherein the distance between the first wall 2 and the second wall 4 reduces slightly when moving away from the flow louver. This makes it possible that the filter 24 does not necessarily need to be fastened to the air guide 1, but it is supported by the first wall 2 and the second wall 4, between them.

[0024] The air guide 1 according to the invention can be fastened to the first casement 11a of the window by means of, for example, double sided tape, magnetic tape 23 that is, for example, glued to the first wall 2 of the air guide as shown in Fig. 2, sticker tape, or the like.

[0025] The first interspace 10a and the second interspace 10b of the window 3 can be arranged in a flow connection with each other advantageously in the vicinity of the lower edge of the window, wherein the replacement air flowing into the first interspace 10a can move into the second interspace 10b of the window. Thus, the air flow duct 16 of the replacement air valve 14 is placed advantageously in the second built-in frame. Thus, the replacement air entering the lower part of the second interspace 10b can flow upwards in this second interspace 10b and further through the air flow duct 16 into the replacement air valve 14.

[0026] Even if the invention was described above in connection with a window, the air guide 1 according to the invention can also be used, for example, in connection with a door arrangement for a balcony or a terrace. Such a door arrangement preferably comprises two doors, wherein a relatively tight interspace is left between these two doors (not shown) when both of the doors are closed. The air guide 1 according to the invention is fastened at the upper edge of the outermost door, where at

least part of the sealing is removed, if necessary, to enable the flow of replacement air from outdoor air via the air guide into the interspace between the doors. A replacement air valve can be provided at the upper edge of the inner door or in its upper built-in frame, through which valve the replacement air that has entered the interspace can be led into the room.

[0027] It is obvious that the present invention is not limited solely to the above-presented embodiments but it can be modified within the scope of the appended claims.

Claims

1. An air guide (1) for a window (3), the window comprising at least a first casement (11a) to which a first pane (9a) is fastened, and a second casement (11b) to which a second pane (9b) is fastened, wherein an interspace (10a) is provided between the first pane (9a) and the second pane (9b), wherein the air guide (1) comprises a first wall (2), a second wall (4), a flow louver (5) between the first wall (2) and the second wall (4), and an air flow guide wall (8) for guiding the replacement air into said first interspace (10a) of the window, wherein the first wall (2), the second wall (4) and the flow louver (5) form a first inlet (6) for conveying replacement air into the air guide (1), wherein the air guide (1) comprises means (23) for fastening the air guide to the first casement (11a) of the window (3), **characterized in that** the distance between the first wall (2) and the second wall (4) reduces slightly when moving away from the flow louver (5), and **in that** a filter (24) is supported by the first wall (2) and the second wall (4), between them.
2. The air guide (1) according to claim 1, **characterized in that** the means (23) for fastening the air guide is arranged to be fastened to the first casement (11a) of the window (3) by at least one of the following:
 - double sided tape;
 - magnetic tape.
3. A window (3) comprising at least a first casement (11a), to which a first pane (9a) is fastened, and a second casement (11b), to which a second pane (9b) is fastened, and a built-in frame (12) with which the first casement (11a) and the second casement (11b) are adapted to be attached, wherein an interspace (10a) is provided between the first pane (9a) and the second pane (9b), and a gap (15) is provided between the first casement (11a) and the built-in frame (12), **characterized in that** the window (1) further comprises an air guide (1) according to any of the claims 1 to 2 in said interspace (10a), wherein the first inlet (6) is adapted to receive replacement air

via said gap (15).

Patentansprüche

1. Luftführung (1) für ein Fenster (3), wobei das Fenster mindestens einen ersten Flügel (11a) umfasst, an dem eine erste Scheibe (9a) befestigt ist, und einen zweiten Flügel (11b), an dem eine zweite Scheibe (9b) befestigt ist, wobei ein Zwischenraum (10a) zwischen der ersten Scheibe (9a) und der zweiten Scheibe (9b) vorgesehen ist, wobei die Luftführung (1) eine erste Wand (2), eine zweite Wand (4), einen Strömungsschlitz (5) zwischen der ersten Wand (2) und der zweiten Wand (4) und eine Luftströmungsführungswand (8) zum Führen der Ersatzluft in den ersten Zwischenraum (10a) des Fensters umfasst, wobei die erste Wand (2), die zweite Wand (4) und der Strömungsschlitz (5) einen ersten Einlass (6) zum Fördern von Ersatzluft in die Luftführung (1) bilden, wobei die Luftführung (1) Mittel (23) zum Befestigen der Luftführung an dem ersten Flügel (11a) des Fensters (3) umfasst, **dadurch gekennzeichnet, dass** sich der Abstand zwischen der ersten Wand (2) und der zweiten Wand (4) beim Wegbewegen von de Strömungsschlitz (5) geringfügig verringert, und dass ein Filter (24) von der ersten Wand (2) und der zweiten Wand (4) zwischen ihnen getragen wird.
2. Luftführung (1) nach Anspruch 1, **dadurch gekennzeichnet, dass** das Mittel (23) zum Befestigen der Luftführung angeordnet ist, um an dem ersten Flügel (11a) des Fensters (3) durch mindestens eines der folgenden befestigt zu werden:
 - doppelseitiges Klebeband;
 - Magnetband.
3. Fenster (3), das mindestens einen ersten Flügel (11a) umfasst, an dem eine erste Scheibe (9a) befestigt ist, und einen zweiten Flügel (11b), an dem eine zweite Scheibe (9b) befestigt ist, und einen eingebauten Rahmen (12), mit dem der erste Flügel (11a) und der zweite Flügel (11b) zum Befestigen angepasst sind, wobei ein Zwischenraum (10a) zwischen der ersten Scheibe (9a) und der zweiten Scheibe (9b) vorgesehen ist und ein Spalt (15) zwischen dem ersten Flügel (11a) und dem eingebauten Rahmen (12) vorgesehen ist, **dadurch gekennzeichnet, dass** das Fenster (1) ferner eine Luftführung (1) gemäß einem der Ansprüche 1 bis 2 in dem Zwischenraum (10a) umfasst, wobei der erste Einlass (6) angepasst ist, um Ersatzluft über den Spalt (15) aufzunehmen.

Revendications

1. Guidage d'air (1) pour une fenêtre (3), la fenêtre comprenant au moins un premier battant (11a) auquel une première vitre (9a) est fixée, et un second battant (11b) auquel une seconde vitre (9b) est fixée, dans lequel un espace intermédiaire (10a) est prévu entre la première vitre (9a) et la seconde vitre (9b), dans lequel le guidage d'air (1) comprend une première paroi (2), une seconde paroi (4), une persienne d'écoulement (5) entre la première paroi (2) et la seconde paroi (4), et une paroi de guidage d'écoulement d'air (8) pour guider l'air de remplacement dans ledit premier espace intermédiaire (10a) de la fenêtre, dans lequel la première paroi (2), la seconde paroi (4) et la persienne d'écoulement (5) forment une première entrée (6) pour transporter de l'air de remplacement dans le guidage d'air (1), dans lequel le guidage d'air (1) comprend un moyen (23) pour fixer le guidage d'air au premier battant (11a) de la fenêtre (3), **caractérisé en ce que** la distance entre la première paroi (2) et la seconde paroi (4) diminue légèrement en s'éloignant de la persienne d'écoulement (5), et **en ce qu'**un filtre (24) est supporté par la première paroi (2) et la seconde paroi (4), entre elles.
2. Guidage d'air (1) selon la revendication 1, **caractérisé en ce que** le moyen (23) pour fixer le guidage d'air est agencé pour être fixé au premier battant (11a) de la fenêtre (3) par au moins l'un des éléments suivants :
- un ruban double face ;
 - un ruban magnétique.
3. Fenêtre (3) comprenant au moins un premier battant (11a), auquel une première vitre (9a) est fixée, et un second battant (11b), auquel une seconde vitre (9b) est fixée, et un cadre intégré (12) avec lequel le premier battant (11a) et le second battant (11b) sont conçus pour être fixés, dans laquelle un espace intermédiaire (10a) est prévu entre la première vitre (9a) et la seconde vitre (9b), et un espace (15) est prévu entre le premier battant (11a) et le cadre intégré (12), **caractérisée en ce que** la fenêtre (1) comprend en outre un guidage d'air (1) selon l'une quelconque des revendications 1 et 2 dans ledit espace intermédiaire (10a), dans laquelle la première entrée (6) est conçue pour recevoir de l'air de remplacement par l'intermédiaire dudit espace (15).

55

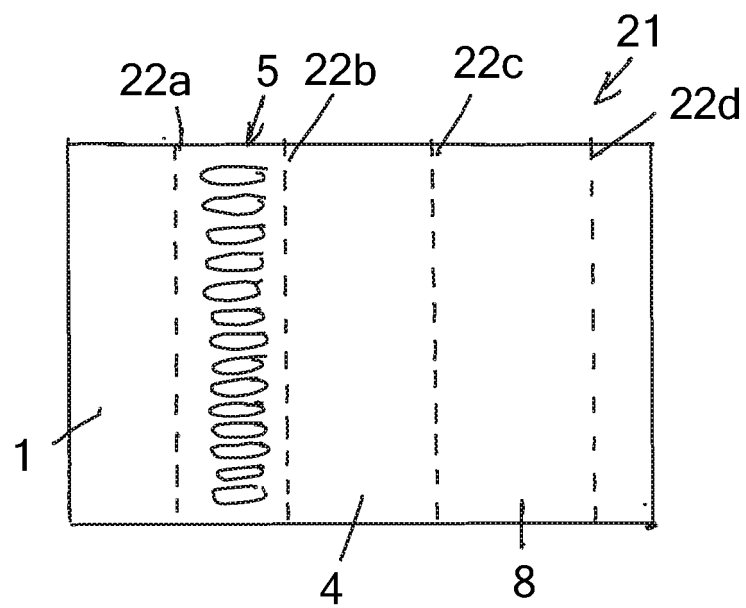
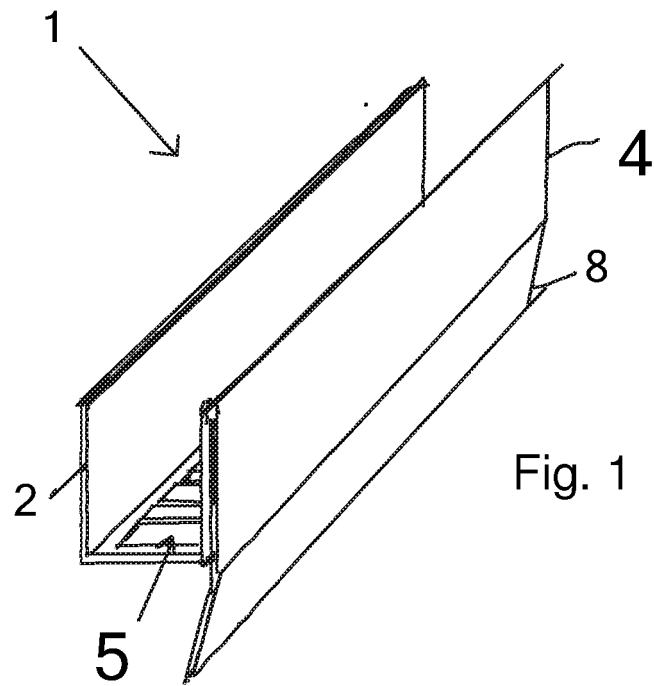

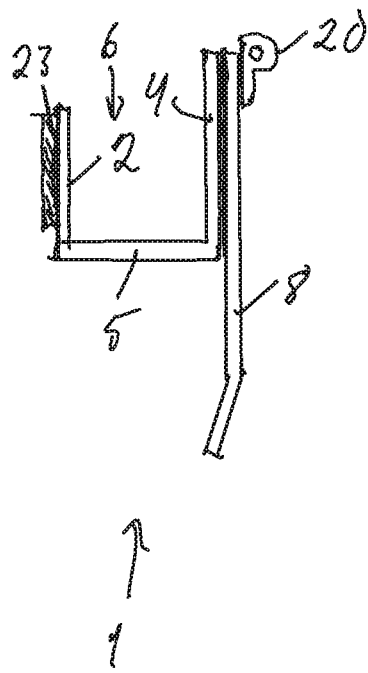

Fig. 5

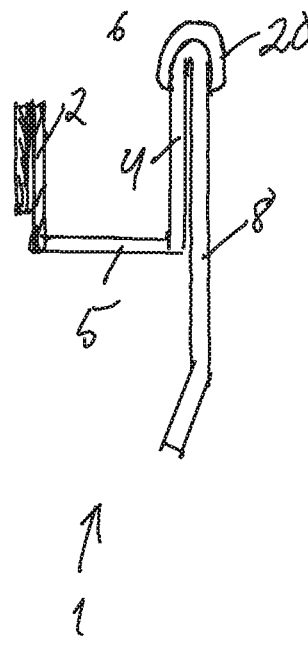

Fig. 2

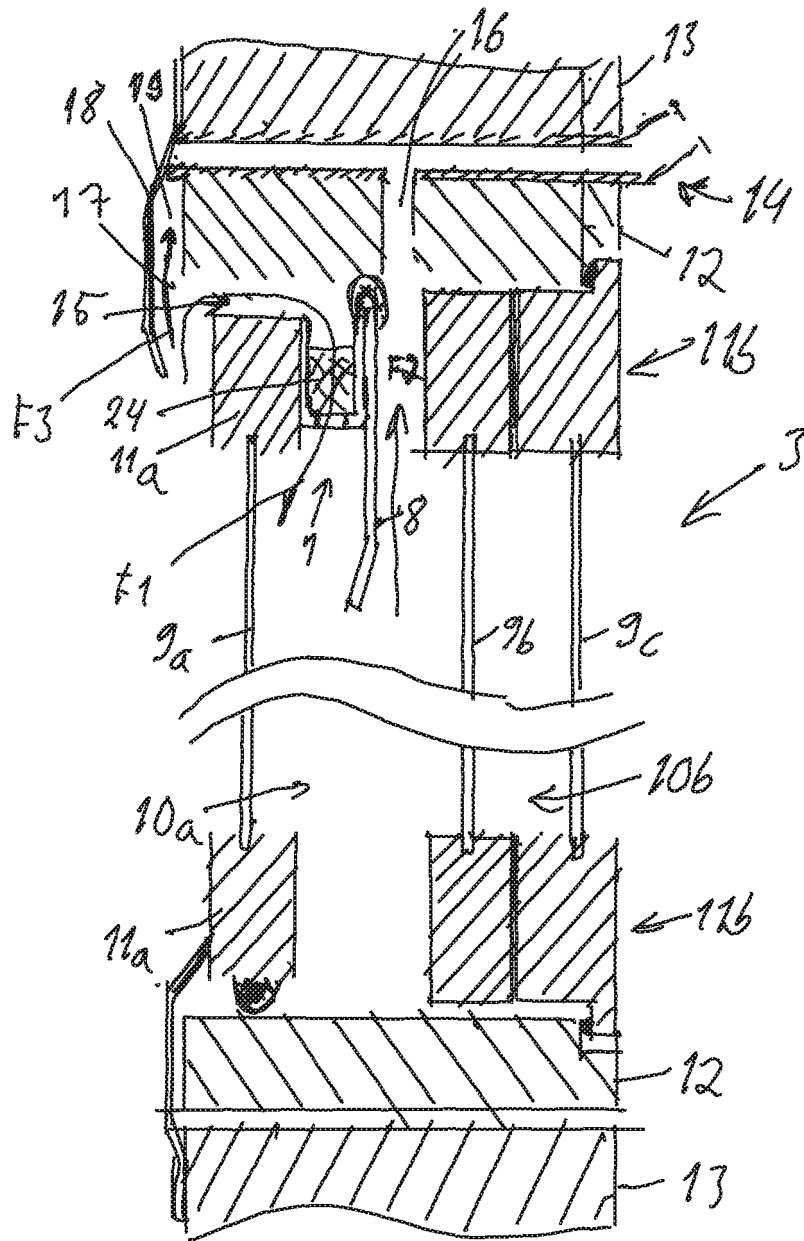

Fig. 3

REFERENCES CITED IN THE DESCRIPTION

This list of references cited by the applicant is for the reader's convenience only. It does not form part of the European patent document. Even though great care has been taken in compiling the references, errors or omissions cannot be excluded and the EPO disclaims all liability in this regard.

Patent documents cited in the description

- DE 29719751 U1 [0005]
- DE 2404836 [0008]