

May 9, 1933.

C. E. JACOBS ET AL

1,908,362

OIL PUMP

Filed Nov. 5, 1931

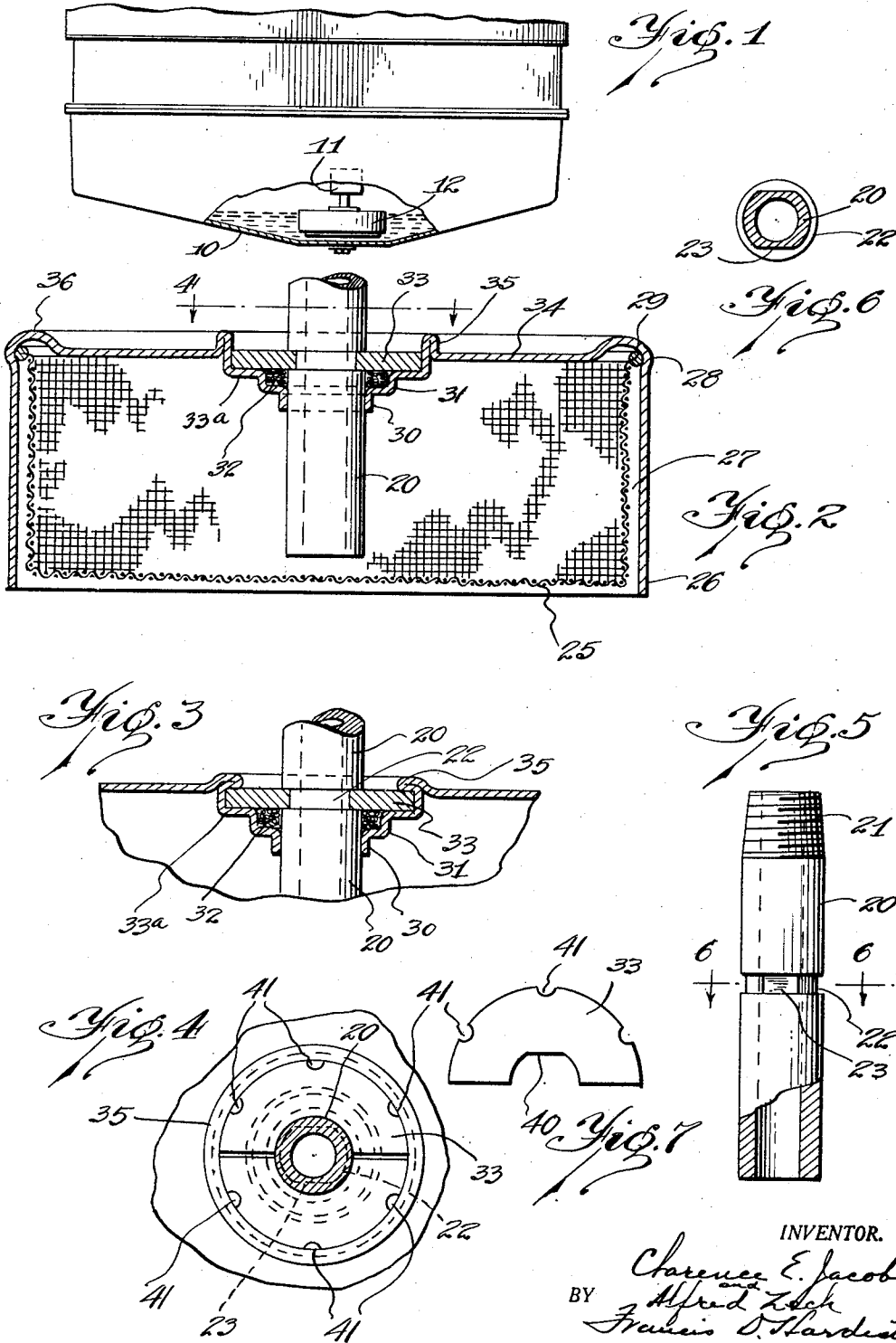

INVENTOR.

Charles E. Jacobs
BY Alfred L. Lohr
Francis D. Hardisty
ATTORNEY.

UNITED STATES PATENT OFFICE

CLARENCE E. JACOBS AND ALFRED ZECH, OF DETROIT, MICHIGAN, ASSIGNORS TO INDUSTRIAL WIRE CLOTH PRODUCTS CORPORATION, OF WAYNE, MICHIGAN, A CORPORATION OF MICHIGAN

OIL PUMP

Application filed November 5, 1931. Serial No. 573,224.

The present invention relates to oil pumps for internal combustion engines, and more especially to the screened inlets for such pumps.

In the conventional practice, it is customary to provide a pump screen of rather large area and to place over the screen, and spaced somewhat from it, a bell which encases the sides and may extend to or below the lowest part of the screen to prevent quick clogging by solid particles or by ice in winter. Difficulty has been experienced, however, in securing the bell over the screen by satisfactory economical means.

Among the objects of the present invention is to overcome this difficulty and provide securing means not only permanent and sufficiently leakproof but low in cost as well.

Other objects will readily occur to those skilled in the art, upon reference to the following description and the accompanying drawing in which:

Fig. 1 is a more or less diagrammatic view, with parts broken away, of an engine crank case in side elevation, showing the use and location of the present device.

Fig. 2 is a vertical central section through the screen and bell in process of assembly.

Fig. 3 is a part of the same, showing the parts as assembled.

Fig. 4 is a section substantially on line 4—4 of Fig. 2 looking in the direction of the arrows.

Fig. 5 is a partly sectional and partly side elevational view of the pump inlet pipe.

Fig. 6 is a section substantially on line 6—6 of Fig. 5 and looking in the direction of the arrows, and

Fig. 7 is a detail plan view of a part of the securing means.

In the drawing the lower part of an internal combustion engine including a crank case is shown in Fig. 1, with the crankcase and oil sump indicated at 10. In the latter is arranged an oil pump 11 having a suitable delivery conduit (not shown) leading to the moving parts to be lubricated.

The pump is shown as mounted upon or just above a screened inlet chamber 12 from which

the pump draws lubricant free from screen separable matter.

The screen chamber construction is shown more in detail in enlarged Figs. 2 to 7, and comprises an inlet pipe 20 threaded at its upper end as at 21 for securing to the pump 11, and near its lower end provided with an annular groove 22 which is deepened at two diametrically opposite portions to provide flats 23. This inlet pipe 20 also forms the support for the screen chamber and the screen 25.

The screen may be cup shaped as shown, and secured in any suitable fashion, open end up, within a bell 26 which in the form shown extends to preferably just below the screen and is sufficiently larger than the same to provide a space 27 around the sides of the screen. The shown method of securing the screen in place, consists in providing the inner surface of the bell with a shallow groove 28 near its top and the upper edge of the screen with a resilient ring 29 which expands into the groove when forced thereto.

The upper surface 34 of the bell 26 is formed, as indicated in Fig. 2, with a central downwardly flanged opening 30 very slightly greater than the outside diameter of pipe 20. Surrounding the opening 30 is a gasket seat 31 also formed of the metal of the bell as a rabbet surrounding the flange 30, to receive a suitable gasket 32. Surrounding and above the seat 31 is another flat shoulder portion 33a for receiving a split disc or washer 33, formed in two substantially semi-circular portions. The shoulder 33a is also sufficiently below the top of the bell to make the upper surface of washer 33 substantially flush with or slightly below or above the surface 34. Around the shoulder portion 33a, the metal of the bell 26 is so formed as to provide an upstanding folded flange 35, which is, under the circumstances, double. The remaining upper portion of the bell may be flat, or as shown, provided with a stiffening rib 36.

In assembling the parts, the split washer sections 33 are first placed in groove 22, the inner opening of the washer sections having suitable flats 40 to cooperate with flats 23 in the groove. The end of the pipe 20 is then

thrust through opening 30, gasket 32 being in place, and the washer 33 seated on the shoulder 33a within flange 35. The parts then occupy the position shown in Fig. 2.

5 After the parts are so assembled, the flange 35 is turned in, as shown in Fig. 3, upon the outer edge of the washer 33, holding the parts in permanently fixed relation.

10 In order to more definitely fix the parts against relative rotary movement, the outer edges of washer 33 may be notched as at 41 so that some of the metal of flange 35 may flow into the notches.

15 When the flange 35 has been turned down as shown, there is produced a substantially liquid tight joint and one which will withstand the stress occasioned by threading the pipe 20 into the pump housing.

20 It is contemplated to omit the gasket 32 and seat 31 and also the notches 33, as under some conditions these may be found unnecessary.

25 Now having described the invention and the preferred embodiment thereof, it is to be understood that the said invention is to be limited, not to the specific details herein set forth, but only by the scope of the claims which follow:

I claim:

30 1. In a screened pump inlet, a screen, a bell covering said screen to form a pump inlet chamber, and a pump inlet conduit extending through said bell into said chamber, means for mounting the bell upon said conduit comprising an opening for said conduit, a seat surrounding said opening, a metallic washer on said seat means for fixing said washer against longitudinal movement with respect to said conduit, and means for fixing said washer upon said seat.

40 2. In a screened pump inlet, a screen, a bell covering said screen to form a pump inlet chamber, and a pump inlet conduit extending through said bell into said chamber, means for mounting the bell upon said conduit comprising a split washer having a flattened portion on its inner periphery, a peripheral channel on said conduit adapted to receive said washer, there being a flattened portion in said channel bottom to cooperate with said first mentioned flattened portion, and means to fix said washer to said bell against movement.

50 3. In a screened pump inlet having a screen, a bell covering said screen to form a pump inlet chamber, and a pump inlet conduit extending through said bell into said chamber, means for mounting the bell upon said conduit comprising a split washer having a flattened portion on its inner periphery, a seat for said washer concentric with the opening for said conduit, a peripheral channel on said conduit adapted to receive said washer, there being a flattened portion in said channel bottom to cooperate with said first

mentioned flattened portion, and means to fix said washer upon said seat.

4. In a screened pump inlet, a screen, a bell covering said screen to form a pump inlet chamber, and a pump inlet conduit extending through said bell into said chamber, means for mounting the bell upon said conduit comprising a flanged opening for said conduit, a seat concentric with said opening, a flange integral with said bell and surrounding said seat, and a washer on said seat and provided with means for gripping said conduit, said last mentioned flange being pressed down upon said washer to thereby fix it against movement.

5. In a screened pump inlet, a screen, a bell covering said screen to form a pump inlet chamber, and a pump inlet conduit extending through said bell into said chamber, said conduit being provided with a peripheral channel of uneven depth a short distance from its inlet end, and said bell having a suitable opening to receive said conduit, means for fixing said conduit in said opening comprising a washer having an inner periphery corresponding to the contour of the bottom of said channel and adapted to lie therein, a seat for said washer around said opening, and means for fixing said washer upon said seat against rotation or displacement.

6. In a screened pump inlet member, a screen, a bell partly covering said screen to form an inlet chamber, and a pump inlet conduit extending through the bell into said chamber, means for mounting the bell upon the conduit comprising an opening in the bell for said conduit, a seat surrounding said opening, a metallic locking member on said seat and engaging the conduit, means for fixing said locking member against longitudinal and rotative movement with respect to the conduit, and means for fixing said locking member upon the seat.

In testimony whereof, we sign this specification.

CLARENCE E. JACOBS.
ALFRED ZECH.