



**EUROPEAN PATENT APPLICATION**

Application number : **92309787.7**

Int. Cl.<sup>5</sup> : **B66B 7/06**

Date of filing : **26.10.92**

Priority : **25.10.91 JP 87670/91**

Inventor : **Kawarasaki, Masashi**  
**Akitsu 2-2-1-202**  
**Narashino-shi, Chiba-ken (JP)**

Date of publication of application :  
**28.04.93 Bulletin 93/17**

Designated Contracting States :  
**DE FR GB**

Representative : **Tomlinson, Kerry John**  
**Frank B. Dehn & Co. European Patent**  
**Attorneys Imperial House 15-19 Kingsway**  
**London WC2B 6UZ (GB)**

Applicant : **OTIS ELEVATOR COMPANY**  
**Four Farm Springs**  
**Farmington Connecticut 06032 (US)**

**Roping method of an elevator.**

An elevator is provided having a car, with a ceiling defined by a width and a depth, a counterweight, a plurality of ropes, a pair of first sheaves, a pair of second sheaves, and a pair of third sheaves. The car and the counterweight are connected by a plurality of ropes extending from the car to the first sheave, and then to the second sheave, then to the third sheave, and finally to the counterweight. The sheaves are positioned inside the hoistway, outside of the projected horizontal area of the ceiling of the car and therefore not directly above the ceiling in the hoistway.

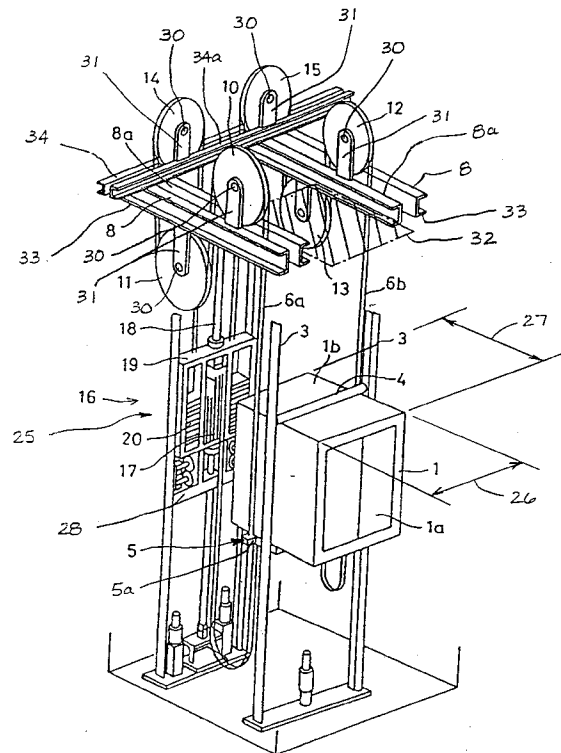

FIG.3

This invention relates to elevators, and in particularly to the roping of an elevator in a hoistway.

Elevators typically consist of an elevator car, a counterweight, a plurality of ropes, and a sheave, all located in a hoistway. The ropes connect the elevator car and counterweight. Conventionally, one end of each rope attaches to a support frame connected to the ceiling of the car. From there the ropes extend up the hoistway to the sheave attached to overhead beams located directly above the car at the top of the hoistway. The ropes then wrap around the sheave and return back down the hoistway, finally attaching to the counterweight.

Service personnel checking or performing maintenance on this type of elevator are required to perform some of their operations on the support frame above the car. To avoid service personnel being crushed between the ceiling of the car and the overhead beams supporting the sheave, safety codes require a prescribed amount of overhead space be provided between the support frame and the overhead beam. Space is also required between the ceiling of the car and the top of the support frame. This space also contributes to the unusable space in the hoistway. In sum, an elevator using this type of conventional arrangement has a minimum of unusable space equal to the code required space plus the space from the ceiling of the car to the top of the support frame. Any space that cannot be used in a building detracts from the value of the building, and it is, therefore, desirable to minimize the unusable space.

It is, therefore, an object of the present invention to provide an elevator which minimizes the unusable amount of building space necessary in a hoistway.

According to the present invention, an elevator is provided having a car with a horizontal area, a counterweight, a plurality of rope portions, and a plurality of sheaves. The car and the counterweight are connected by the ropes extending from the car to the sheaves, and finally to the counterweight. The sheaves are positioned inside the hoistway, outside of the protected horizontal area of the car and therefore not above the car in the hoistway.

An advantage to the roping arrangement of the present invention is that the space necessary for the sheaves at the top of the hoistway also provides the code required space for service. Placing the sheaves outside of the travel path of the elevator car enables the space to be used both for the sheaves and for the required service space thereby reducing the total amount of unusable space in the hoistway.

These and other objects, features and advantages of the present invention will become more apparent in light of the detailed description of an embodiment thereof, given by way of example only, as illustrated in the accompanying drawings.

FIG.1 is a diagrammatic view of the prior art method of roping the counterweight to the elevator

car.

FIG.2 is a diagrammatic view of prior art FIG.1 showing the elevator car and counterweight in relation to the entire hoistway.

FIG.3 is a diagrammatic view of the elevator showing a roping method of the present invention connecting the car and the counterweight by ropes outside of the projected horizontal area of the elevator car.

FIG.4 is a diagrammatic view of FIG.3 showing the elevator car and counterweight in relation to the entire hoistway.

Referring to prior art FIGS. 1 and 2, a conventional elevator is shown having an elevator car 101, a counterweight 112, a plurality of ropes 103, and a number of sheaves 106, 107, all located in a hoistway 110. The elevator car 101 has a ceiling 101a and a support frame 102 attached to that ceiling 101a. The counterweight 112 consists of a frame 113, weights 114, and the primary 108a of a linear motor 108. The linear motor 108 comprises the aforementioned movable primary 108a and a secondary 116 consisting of a ferromagnetic cylindrical column received by the primary 108a. The column 116 extends the length of the hoistway 110 and is attached to the hoistway 110 at the top 109 and the bottom 117 of the hoistway 110. Attractive and repulsive forces between the primary 108a and secondary 116 power the counterweight 112, and therefore the attached elevator car 101, up and down the hoistway 110.

One end of each rope 103 is attached to the support frame 102 attached to the ceiling 101a of the car 101. From there the ropes 103 extend up the hoistway 110 to the sheaves 106, 107. The sheaves 106, 107 are attached to overhead beams 105 located directly above the car 101 at the top 109 of the hoistway 110. The ropes 103 wrap around the sheaves 106, 107 and return back down the hoistway 110, finally attaching to the counterweight 112. A minimum space 118 is required between the support frame 102 and the overhead beams 105 for safety purposes. Space 120 is also required between the ceiling 101a of the car 101 and the top of the support frame 102 attached to the car 101. This space 120 contributes to the unusable space in the hoistway 110. An elevator using this type of conventional arrangement has, therefore, a minimum of unusable space equal to the code required space 118 plus the space 120 from the ceiling 101a of the car 101 to the top of the support beam 102.

Now referring to FIGS.3 and 4, in the present invention an elevator is provided having a car 1, a counterweight 25, a pair of ropes 6a, 6b, a pair of first sheaves 10, 12, a pair of second sheaves 11, 13, and a pair of third sheaves 14, 15. The car 1 has a ceiling 1b whose horizontal area is defined by a width 26 and a depth 27. A support frame 4 is attached to the ceiling 1b of the car 1 and a suspending frame 5 is attach-

ed to the floor of the car 1. The suspending frame 5 has extensions 5a projecting beyond the left and right sides of the car 1, passing through the center of gravity of the car 1.

The counterweight 25 consists of a frame 28, weights 20, and the primary 17 of a linear motor 16. The linear motor 16 comprises the aforementioned movable primary 17 and a secondary 18 consisting of a ferromagnetic cylindrical column received by the primary 17. The column extends the length of the hoistway 2 and is attached to the hoistway 2 at the top 21 and the bottom 29 of the hoistway 2. The weight of the counterweight 25, including the primary 17, is set to equal the combined weight of the car 1 and the half of the weight of the rated maximum load of the elevator.

The first 10, 12, second 11, 13, and third 14, 15 pairs of sheaves are cylindrical sheaves rotatably counted on axles 30. Each axle 30 is received and supported by a sheave bracket 31 having an arm on each side of the sheave. Each sheave bracket 31 is attached to and supported by a pair of spaced apart structural beams 8, 8a.

To move the elevator car 1 up and down the hoistway 2, current is introduced into the primary 17 of the linear motor 16. Attractive and repulsive forces produced by the current passing through the primary 17 provide the motive force necessary to move the counterweight 25. Because the counterweight 25 is attached to the elevator car 1 by a pair of ropes 6a, 6b in communication with the sheaves, the car is also propelled through the hoistway 2, but in a direction opposite that of the counterweight 25.

One rope 6a is attached to an extension 5a of the suspending frame 5 projecting horizontally outward from the floor of the car on the left side of the car 1, and the other rope 6b is attached to an extension 5a of the suspending frame projecting horizontally outward from the floor of the car 1 on the right side. Each first sheave 10, 12 is mounted on a pair of spaced apart parallel structural beams 8, 8a at the top of the hoistway 2. The ropes 6a, 6b extending directly up from the extensions 5a, pass between the beams 8, 8a and enter the first sheaves 10, 12 centered on the beams 8, 8a. The ropes 6a, 6b are attached to the extensions 5a far enough away from the car 1 such that neither the beams 8, 8a nor the sheaves 10, 12 are located in the projected horizontal area 32 of the car 1. The projected horizontal area 32 of the car 1 is defined by the width 26 and the depth 27 of the car projected directly upward in the hoistway 2.

Each rope 6a, 6b then wraps around the respective first sheave 10, 12 and passes back down between the structural beams 8, 8a to the second sheave 11, 13. The second sheaves 11, 13 are supported and centered on the same structural beams 8, 8a as the first sheaves 10, 12, but are located on the side opposite the first sheaves 10, 12. Each rope 6a,

6b wraps around the respective second sheave 11, 13 and exits passing upward back between the parallel, spaced apart structural beams 8, 8a, and is received by a third sheave 14, 15.

The third sheaves are supported by a pair of parallel, spaced apart structural beams 34, 34a attached to the top of the structural beams 8, 8a supporting the first 10, 12 and second 11, 13 sheaves. Like the first 10, 12 and second 11, 13 sheaves, the third sheaves 14 15 and beams 34, 34a are positioned outside of the projected horizontal area 32 of the car 1. The ropes 6a, 6b wrap around the third sheaves 14, 15, exiting the third sheaves 14, 15 directly above the counterweight 25. The ropes 6a, 6b then attach to the counterweight 25, thereby fixing the counterweight 25 and the car 1 to one another.

Alternatively, a single rope may be used to connect the elevator car 1 and the counterweight 25. In such a case, the rope would attach to one side of the car 1 and extend upward to the sheave(s) on that side of the car. From there, the rope would either engage other sheaves and extend down to a sheave attached to the counterweight 25, or extend directly down to a sheave attached to the counterweight 25. The rope would then extend back up to the sheave(s) on the opposite side of the car 1 and return back to the car 1 along a path similar to that taken on the first side. In this case two portions of the single rope would follow the paths of the separate ropes 6a, 6b.

In sum, the roping arrangement described heretofore saves space in two significant ways. First, all of the sheaves and the structural beams supporting them are positioned outside of the projected horizontal area 32 of the car 1. Consequently, the space 35 required by code above the car 1 is inside of the beams 8, 8a, 34, 34c and sheaves 10 - 15 and extends up to the ceiling 21 of the hoistway 2; thereby eliminating the space required for the overhead beams 105 (see FIGS. 1 and 2) and sheaves. Second, the rope portions 6a, 6b are attached to the suspending frame 5 below the car 1. As a result, the unusable space between the ceiling 1b of the car 1 and the support frame 102 (see FIGS. 1 and 2) beam is eliminated.

## Claims

1. An elevator comprising:
  - a car, having a horizontal area defined by a width and a depth, for movement up and down a hoistway;
  - a counterweight, for movement up and down a hoistway;
  - a plurality of rope portions connecting said car to said counterweight; and
  - a plurality of sheaves, positioned in said hoistway outside of said horizontal area projected

upward in said hoistway, and therefore not directly above said car, wherein said rope portions extend from said car to said sheaves, wrap around said sheaves, and extend to said counterweight.

5

2. An elevator according to claim 1, wherein said counterweight further comprises:

means for driving said counterweight, and therefore said attached car, up and down said hoistway.

10

3. An elevator according to claim 1 or 2, wherein said plurality of sheaves comprises:

a pair of first sheaves, positioned in the hoistway;

15

a pair of second sheaves, positioned in the hoistway; and

a pair of third sheaves, positioned in the hoistway, wherein said sheaves are positioned

20

outside of said horizontal area projected upward in said hoistway and therefore not directly above said car, and wherein said rope portions extend from said car to said first sheaves, around said first sheaves to said second sheaves, around said second sheaves to said third sheaves, around said third sheaves, and finally to said counterweight.

25

4. An elevator according to claim 3, wherein the sheaves of the first pair are disposed at opposite

30

sides of the hoistway, the sheaves of the second pair are disposed at opposite sides of the hoistway generally coplanar with the respective

sheaves of the first pair, and the sheaves of the third pair are disposed at the rear of the hoistway

35

generally above the counterweight in a common plane generally perpendicular to the planes of the first and second pairs.

5. An elevator according to any preceding claim wherein said car comprises:

40

a lower frame; and

one end of each rope portion is connected to said lower frame of said car.

45

6. A method for roping an elevator having an elevator car with a horizontal area and a counterweight connected by a plurality of ropes in a hoistway, comprising the steps of:

providing a plurality of sheaves, positioned in the hoistway outside of the horizontal area of the car projected upward in the hoistway; and

50

extending the ropes from the car to said sheaves;

wrapping the ropes around said sheaves;

55

and

extending the ropes from said sheaves to said counterweight.

4

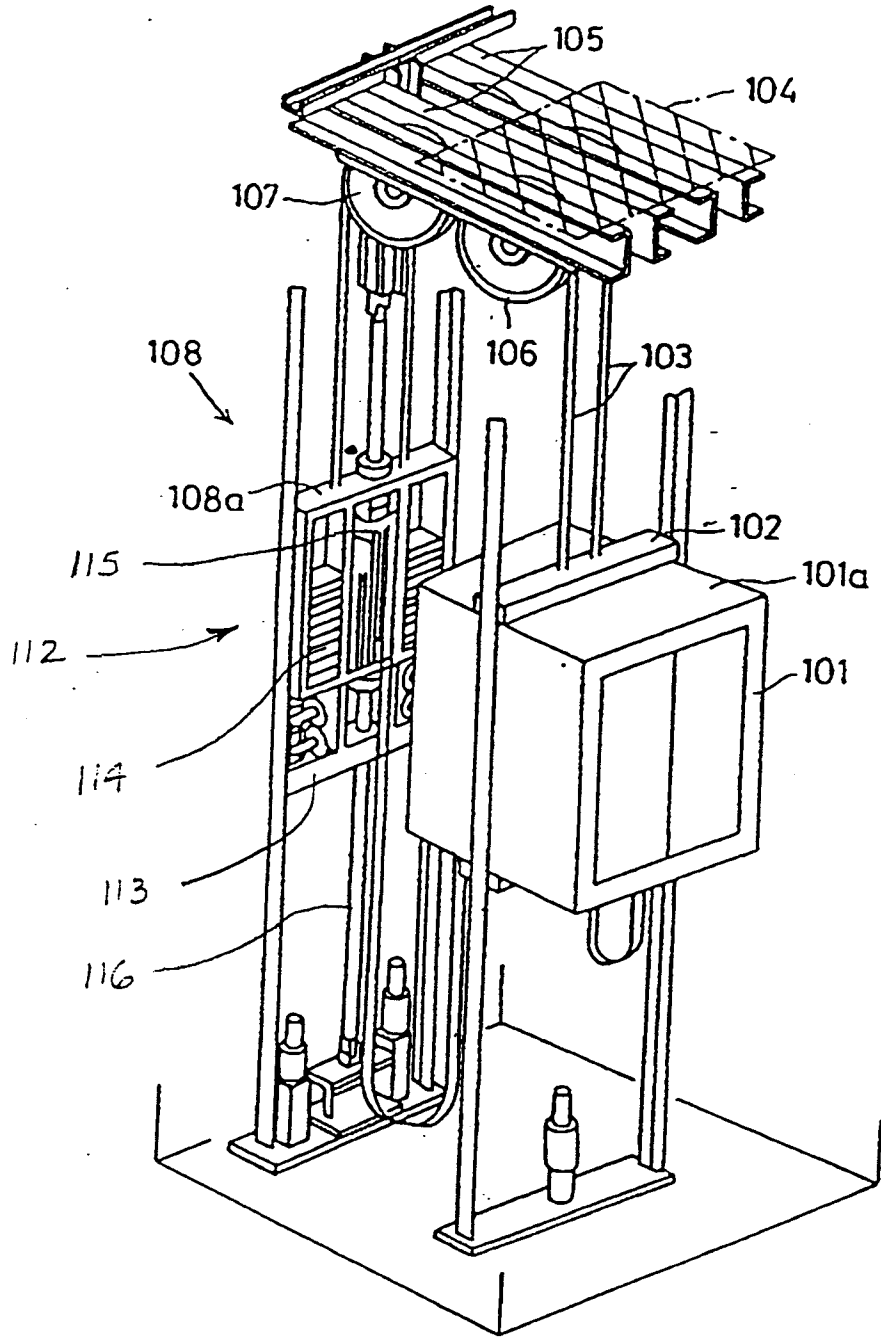

FIG. 1  
PRIOR ART

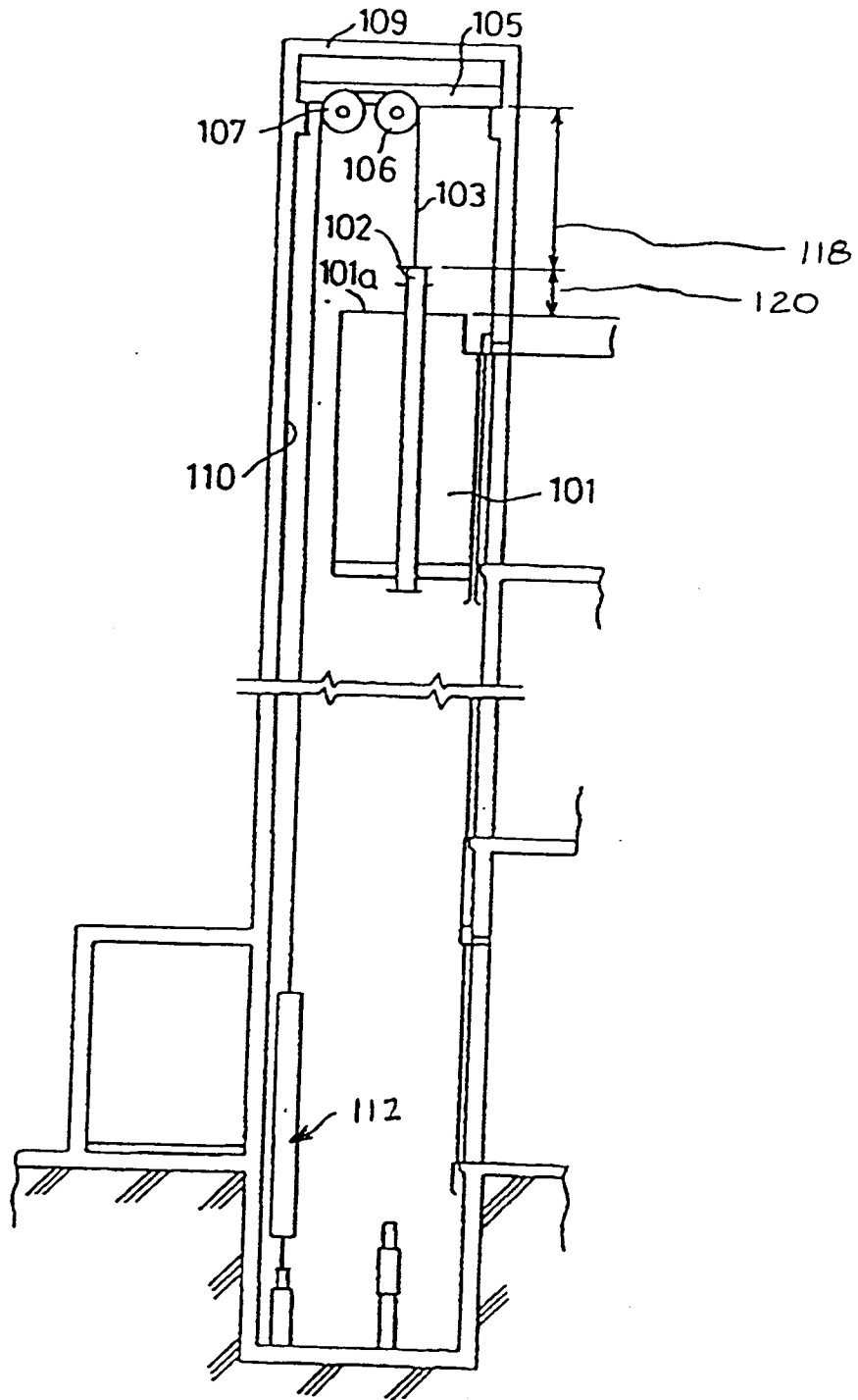

FIG 2  
PRIOR ART

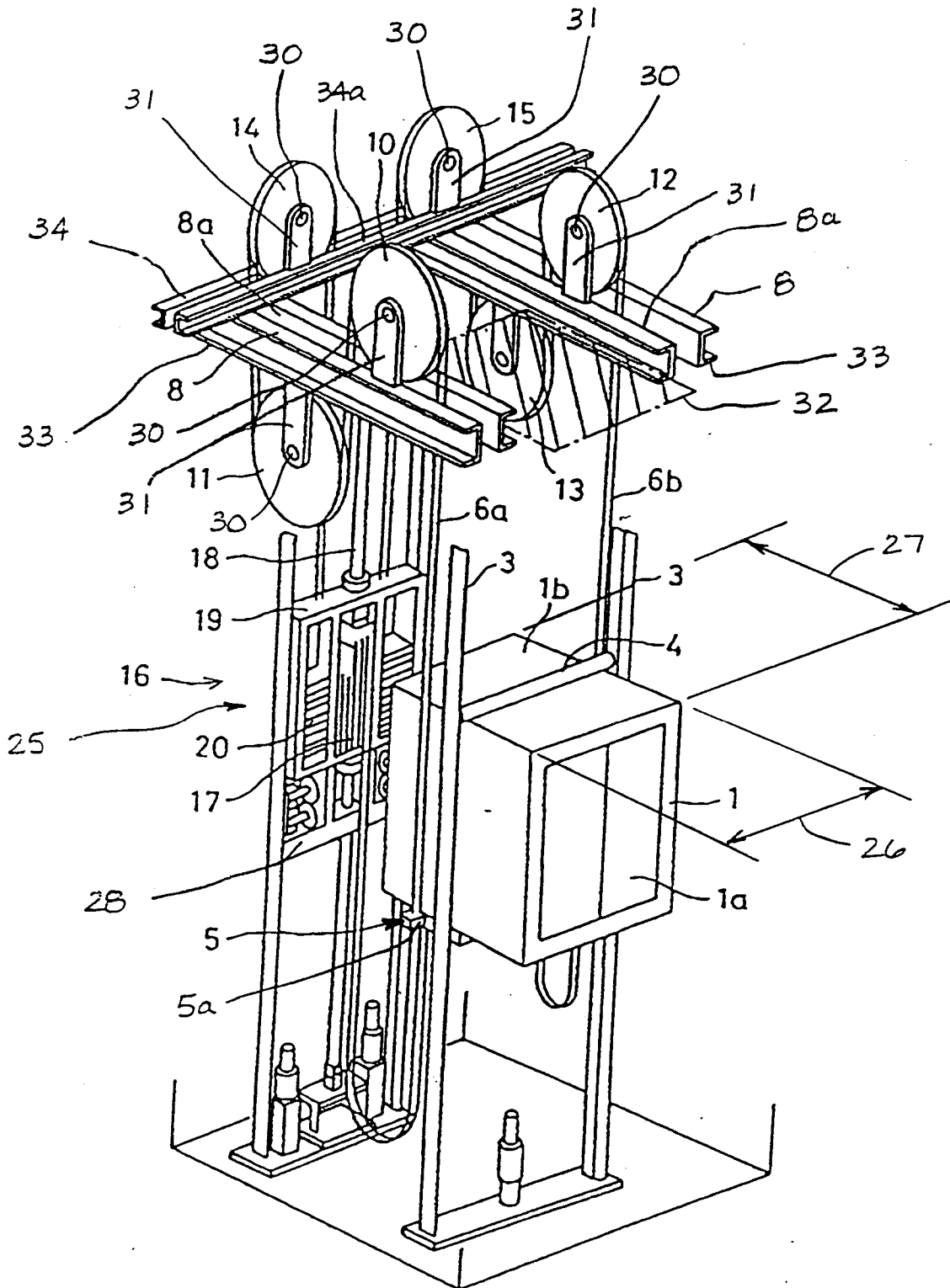

FIG. 3

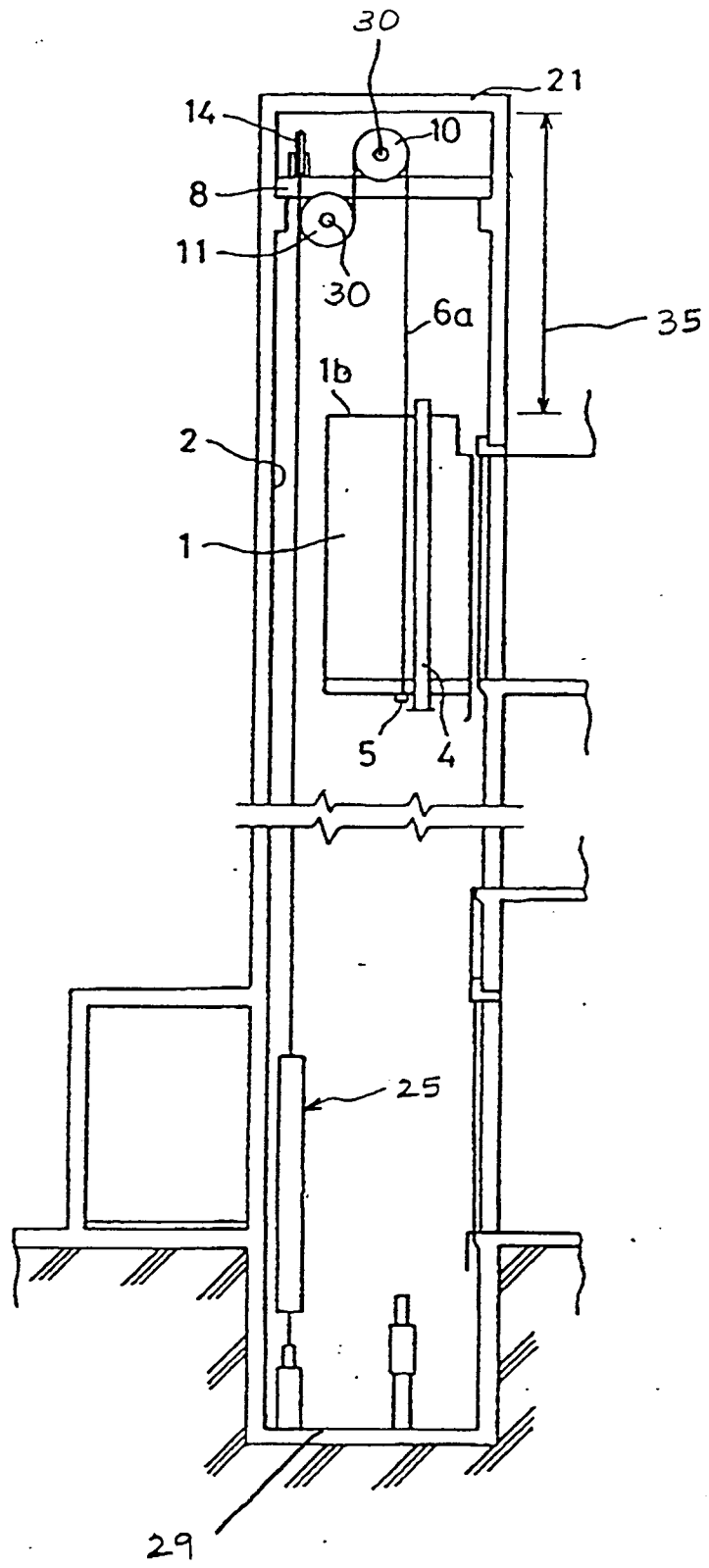

FIG.4