

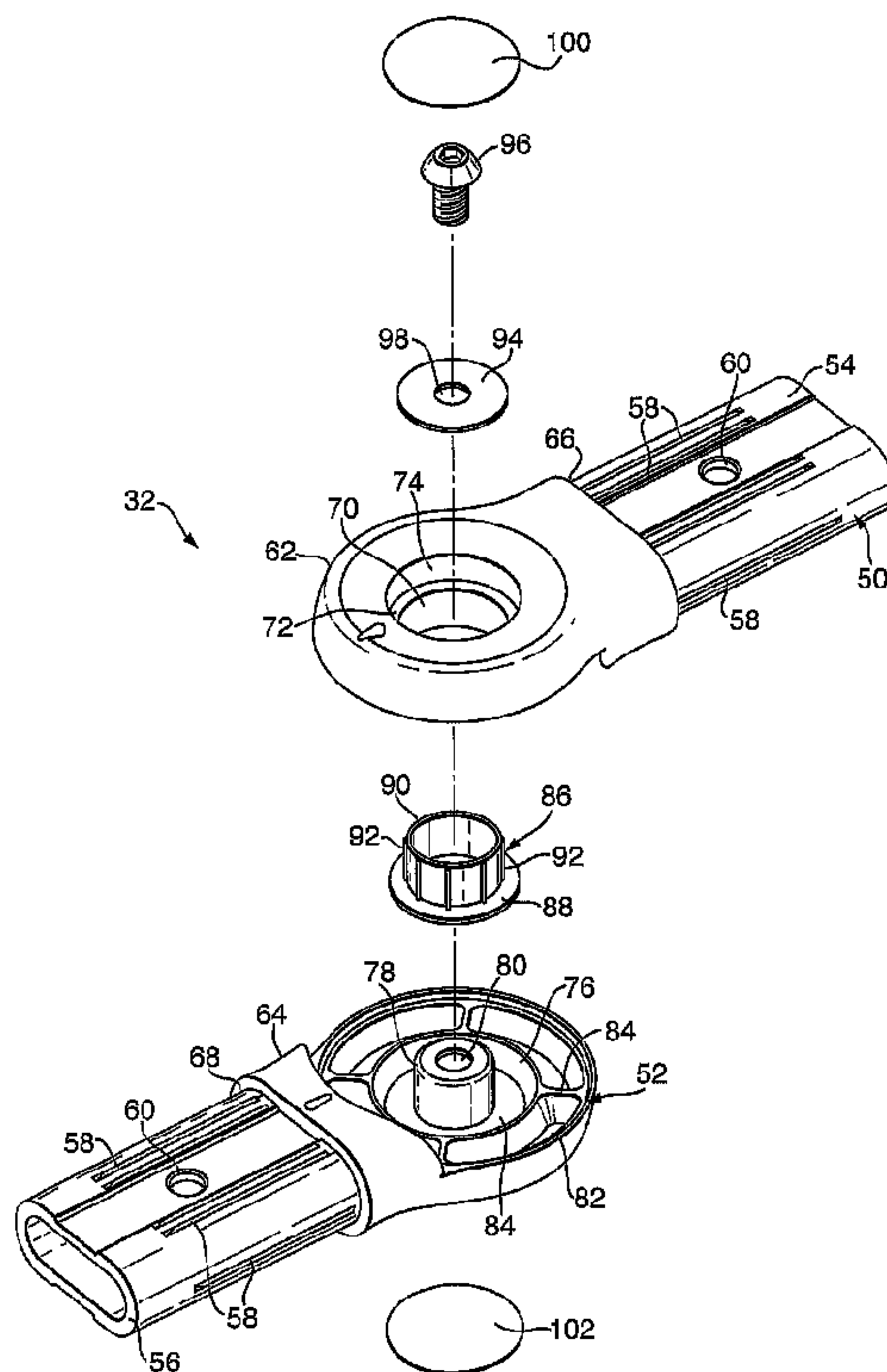

(86) Date de dépôt PCT/PCT Filing Date: 2006/07/17
 (87) Date publication PCT/PCT Publication Date: 2007/01/25
 (45) Date de délivrance/Issue Date: 2014/08/26
 (85) Entrée phase nationale/National Entry: 2008/01/18
 (86) N° demande PCT/PCT Application No.: GB 2006/002653
 (87) N° publication PCT/PCT Publication No.: 2007/010234
 (30) Priorités/Priorities: 2005/07/20 (GB0514926.5);
 2005/11/14 (GB0523169.1)

(51) Cl.Int./Int.Cl. *A47C 19/12* (2006.01),
E05D 5/02 (2006.01)
 (72) Inventeurs/Inventors:
 HAYES, STEPHEN, GB;
 HOLLYOAK, STEPHEN, GB
 (73) Propriétaire/Owner:
 HUNTLEIGH TECHNOLOGY LIMITED, GB
 (74) Agent: TORYS LLP

(54) Titre : CHARNIERE POUR ASSEMBLAGE DE CADRE DE LIT
 (54) Title: A HINGE FOR BED FRAME ASSEMBLY



(57) Abrégé/Abstract:

A hinge assembly (32-36) for a frame assembly (20) of, for example, a hospital bed, has a smooth outer form which substantially conforms to the outer size of frame assembly struts to which it couples. The hinge assembly (32-36) has its components located internally and provides at least one reliable electrically conductive path therethrough so as to provide an electrical connection between frame struts (24-30) coupled together by the hinge (32-36), avoiding the need for electrical wires. There are provided angle markers on the hinge to indicate the degree of rotation of the hinge halves (50 52).



(12) INTERNATIONAL APPLICATION PUBLISHED UNDER THE PATENT COOPERATION TREATY (PCT)

(19) World Intellectual Property Organization
International Bureau(43) International Publication Date
25 January 2007 (25.01.2007)

PCT

(10) International Publication Number
WO 2007/010234 A1

(51) International Patent Classification:

A47C 19/12 (2006.01) E05D 5/02 (2006.01)

(21) International Application Number:

PCT/GB2006/002653

(22) International Filing Date: 17 July 2006 (17.07.2006)

(25) Filing Language: English

(26) Publication Language: English

(30) Priority Data:

0514926.5 20 July 2005 (20.07.2005) GB
0523169.1 14 November 2005 (14.11.2005) GB(71) Applicant (for all designated States except US):
HUNTLEIGH TECHNOLOGY PLC [GB/GB];
310-312 Dallow Road, Luton, Bedfordshire LU1 1TD
(GB).

(72) Inventors; and

(75) Inventors/Applicants (for US only): **HAYES, Stephen**
[GB/GB]; 46 Wallows Wood, Straits, Lower Gornal,
Dudley, West Midland DY3 3AF (GB). **HOLLYOAK,**Stephen [GB/GB]; 42 Oregon Close, Kingswinford, West
Midlands DY6 8SJ (GB).(74) Agent: **THAKER, Shalini**; Group IP Department,
Huntleigh Technology PLC, 310-312 Dallow Road, Luton,
Bedfordshire LU1 1TD (GB).(81) Designated States (unless otherwise indicated, for every
kind of national protection available): AE, AG, AL, AM,
AT, AU, AZ, BA, BB, BG, BR, BW, BY, BZ, CA, CH, CN,
CO, CR, CU, CZ, DE, DK, DM, DZ, EC, EE, EG, ES, FI,
GB, GD, GE, GH, GM, HN, HR, HU, ID, IL, IN, IS, JP,
KE, KG, KM, KN, KP, KR, KZ, LA, LC, LK, LR, LS, LT,
LU, LV, LY, MA, MD, MG, MK, MN, MW, MX, MZ, NA,
NG, NI, NO, NZ, OM, PG, PH, PL, PT, RO, RS, RU, SC,
SD, SE, SG, SK, SL, SM, SY, TJ, TM, TN, TR, TT, TZ,
UA, UG, US, UZ, VC, VN, ZA, ZM, ZW.(84) Designated States (unless otherwise indicated, for every
kind of regional protection available): ARIPO (BW, GH,
GM, KE, LS, MW, MZ, NA, SD, SL, SZ, TZ, UG, ZM,
ZW), Eurasian (AM, AZ, BY, KG, KZ, MD, RU, TJ, TM),
European (AT, BE, BG, CH, CY, CZ, DE, DK, EE, ES, FI,

[Continued on next page]

(54) Title: A HINGE FOR BED FRAME ASSEMBLY

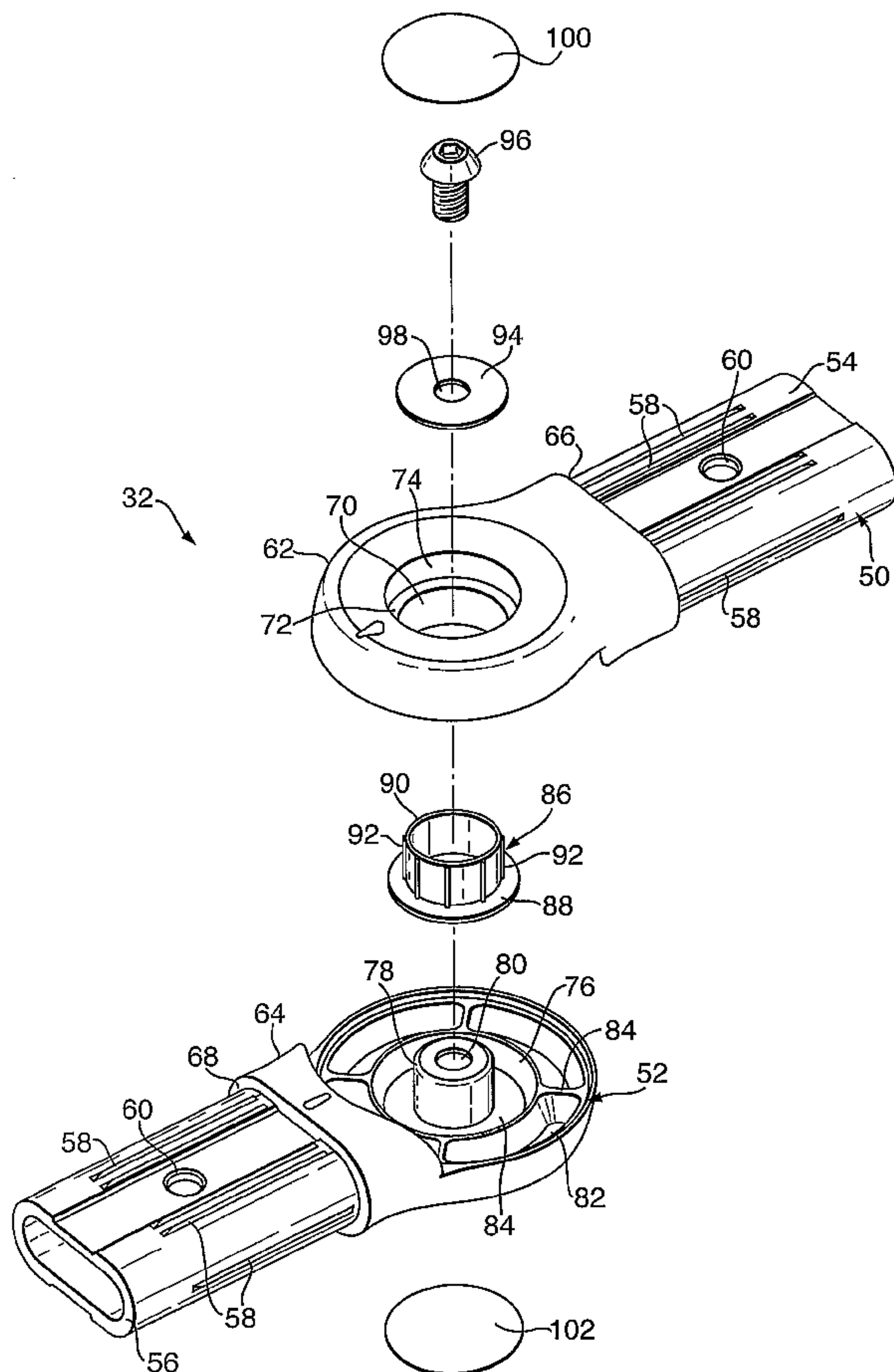
(57) Abstract: A hinge assembly (32-36) for a frame
assembly (20) of, for example, a hospital bed, has a smooth
outer form which substantially conforms to the outer size of
frame assembly struts to which it couples. The hinge
assembly (32-36) has its components located internally and
provides at least one reliable electrically conductive
path therethrough so as to provide an electrical connection
between frame struts (24-30) coupled together by the hinge
(32-36), avoiding the need for electrical wires. There are
provided angle markers on the hinge to indicate the degree
of rotation of the hinge halves (50 52).

WO 2007/010234 A1

WO 2007/010234 A1



FR, GB, GR, HU, IE, IS, IT, LT, LU, LV, MC, NL, PL, PT,
RO, SE, SI, SK, TR), OAPI (BF, BJ, CF, CG, CI, CM, GA,
GN, GQ, GW, ML, MR, NE, SN, TD, TG).

For two-letter codes and other abbreviations, refer to the "Guidance Notes on Codes and Abbreviations" appearing at the beginning of each regular issue of the PCT Gazette.

Published:

— *with international search report*

A HINGE FOR A BED FRAME ASSEMBLY

The present invention relates to a bed frame assembly and in particular to a hinge structure for a configurable bed frame.

Configurable bed frame assemblies have been known for many years. These are provided with a bed frame formed of various portions which can be pivoted relative to one another to configure the bed from a flat configuration to different raised configurations. Typically, the portions include a back rest, a thigh rest and a leg rest. Some beds are also provided with a seat rest between the back rest and the thigh rest. The various portions can be moved or pivoted to raise a patient into a sitting position, to raise a patient's legs only to assist in vascular flow and so on.

Such configurable beds have also for many years been controlled electrically, being provided with a plurality of electrically operated actuators which allow for the bed configuration to be changed by pressing one or more buttons on a key pad. Electrical systems are increasingly being incorporated into such beds to provide other functions and facilities.

An example of a prior art bed assembly is the applicant's well known Contoura range of hospital beds.

The various portions of the bed are typically connected by hinges, either directly to one another or through connecting elements such as supports integral with a bed sub-frame. The hinges are typically provided by bolts and nuts passing through two or more circular apertures in adjacent frame elements or brackets to be coupled pivotally together. These hinges can cause a number of problems in maintaining the bed, particularly in a hospital or care home environment. The hinges tend to form protrusions beyond the pivoted frame elements, which must be covered in order to protect patients and users and also to prevent the accumulation of dirt at the site of the hinges. Thus, the use of tarpaulins or other covers is commonplace in the industry. However, it is not possible to keep such tarpaulins and other covers totally clean, particularly in the current medical environments where "super-bugs" such as MRSA and the like can quickly develop. This has resulted in the need to carry out extensive cleaning maintenance procedures often taking a bed out of service for significant periods of time.

The provision of an electrical supply to such a bed also means that all metallic parts of the bed must be electrically coupled to a fixed voltage, typically ground. This has necessitated the provision of electrical wires connecting together all the metal components

and connecting to ground. Where possible, these wires are located within the cavity of hollow members by welding and then externally to any members which do not have any such cavity. These wires, although performing an essential electrical function, add complexity to the manufacture and structure of the bed and represent another source of possible failure and areas for collection of dirt.

The present invention seeks to provide an improved bed assembly and hinge structure of a bed assembly.

According to an aspect of the present invention, there is provided a frame assembly for a configurable bed including a plurality of movable frame portions formed from one or more frame struts and a hinge assembly including first and second hinge parts each provided with an integral connecting member, each connecting member being able to fit to respective frame struts, the hinge having an outer perimeter which presents a substantially flat surface with one or more outer surfaces of the frame struts to which it connects.

The term substantially flat surface is intended to refer to a surface which does not present a substantial protrusion from the frame struts which could trap dirt or which requires physical separation from a user such as by a cover or tarpaulin. Advantageously, the hinge has an outer perimeter which presents a substantially flat surface with all of outer surfaces of the frame struts to which it connects.

Preferably, the hinge connecting members are able to fit within tubular frame struts. Alternatively, the connecting members are able to fit over an outer surface of the frame struts.

Advantageously, the first and second hinge parts have internal hinge couplings. Thus, no hinge coupling element needs to be provided outside of the flush outer perimeter of the hinge assembly.

Preferably, the hinge assembly is electrically conductive such that a conductive path is provided through the assembly from one of the connecting members to the other. This enables the hinge to provide the electrical coupling between adjacent frame struts without the need for separate electrical wires.

Advantageously, the hinge assembly includes an electrically conductive hinge bush provided between the first and second hinge parts. The bush is preferably an interference fit with one of the hinge parts and abuts the other hinge part. The bush assists in providing a reliable electrical path between the first and second hinge parts and it has been found that

this is more than sufficient and permanent. However, in some instances it is envisaged that the hinge assembly will be provided with an electrically conductive spring element therewithin. The spring element in one embodiment is a coil spring located around the bush and abutting internal walls of the first and second hinge parts. In another
5 embodiment, the spring element is located between the bush and one of the hinge parts, for example a Belleville spring or similar.

Advantageously, the first and second connecting members are provided with a fastening element, in the preferred embodiment an aperture able to receive an electrically conductive rivet or other electrically conductive fastener which would fasten together the
10 hinge connectors to their respective frame strut, thereby providing an even more secure mechanical and electrical coupling.

According to another aspect of the present invention, there is provided a hinge assembly including first and second hinge parts each provided with an integral connecting member, the assembly being electrically conductive such that a conductive path is
15 provided through the assembly from one connecting member to the other.

Advantageously, the hinge assembly includes an electrically conductive hinge bush provided between the first and second hinge parts. The bush is preferably an interference fit with one of the hinge parts and abuts the other hinge part.

In an embodiment the hinge assembly is provided with an electrically conductive
20 spring element therewithin. The spring element in one embodiment is a coil spring located around the bush and abutting internal walls of the first and second hinge parts.

Advantageously, the first and second connecting members are provided with a fastening element, in the preferred embodiment an aperture able to receive an electrically conductive rivet or other electrically conductive fastener which would fasten together the
25 hinge connectors to their respective frame strut.

According to another aspect of the present invention, there is provided a frame assembly for a bed including a hinge structure as herein specified.

According to another aspect of the present invention, there is provided a bed including a hinge structure as herein specified.

30 Embodiments of the present invention are described below, by way of example only, with reference to the accompanying drawings, in which:

Figure 1 shows a perspective view of an embodiment of frame assembly;

Figure 2 is an exploded view of the preferred embodiment of coupling hinge;

Figure 3 is a cross-sectional view of the hinge of Figure 2;

Figure 4 is a front view of the preferred embodiment of hinge assembly; and

Figure 5 is a side elevational view of an example of hospital bed showing a portion
5 of the configurable frame in a bent configuration.

Referring to Figure 1, there is shown a preferred embodiment of bed assembly 10
which includes a wheeled base 12 provided with four castors 14 of conventional type.
Coupled to the base 12 is a bed platform 20 which can be raised and lowered relative to the
base 12 and tilted by means of one or more electrical actuators (not shown), also of
10 conventional type.

The platform 20 is provided with a frame 22 formed, in this embodiment, of four
frame sections 24, 26, 28 and 30 which are coupled to one another by means of hinged
joints 32, 34 and 36.

Each frame section 24-30 is provided with an upper frame member having
15 substantially vertical inner side walls 38 and a plurality of depending transverse struts 40 to
form a recessed support surface for supporting a plurality of mattress support panels,
described in the applicant's co-pending British patent application numbers 0514926.5
and 0523184.0.

The hinges 32, 34 and 36 are provided in the upper frame members 24-30 and
20 enable the frame members to pivot relative to one another about the hinges 32-36.

The frame 22 is typically made of metal or a metal alloy. The frame struts are, in
this embodiment, tubular but could be substantially solid if preferred.

As will be apparent from Figure 1, in this embodiment the frame sections 24-30 are
formed from struts which are of rounded rectangular form in transverse cross-section. Of
25 course, any other cross-section could be used but it is preferred that the outer form is
smooth and has rounded corners. A circular outer profile is a suitable alternative.

The hinges 32-36 have an outer form which complements the outer form of the
frame struts and present substantially flat inner and outer surfaces to the frame 20. There
are no features of the hinges which protrude laterally beyond the frame sections to require
30 special provision such as covering to protect a patient or care staff.

Referring now to Figure 2 there is shown in exploded form a preferred embodiment
of assembly forming the hinges 32-36. Each hinge, which is made substantially entirely of

metal, is formed of first and second metal or metal alloy hinge halves 50, 52 which are externally substantially identical to each other although this is not strictly necessary.

Each hinge half 50, 52 includes a connector element 54, 56 of a rounded rectangular outer form which is of a size to fit tightly within the inner cavity of the tubular frame struts 24-30. There is provided a plurality longitudinally extending metal or metal alloy ribs 58, triangular in transverse cross-section, around the periphery of the connecting elements 54, 56 which will dig into the internal surface of the frame struts 24-30 and which will thereby assist in producing a strong mechanical and electrical coupling between the frame struts and the hinge parts 54, 56.

Each connecting element 54, 56 is also provided with a circular aperture 60 which in use receives a metal rivet 55, 57 (shown in Figure 3) or other suitable fastener which passes through a corresponding aligned hole in the associated frame strut. Such rivet or other fastener can fix the two elements together and guarantee a good electrical coupling, although this feature is not always necessary. A rivet is preferred because of improved assembly and because it can provide a smooth rounded outer surface, which is not possible with a bolt or the like.

The connecting elements 54, 56 are integral with their respective hinge body members 62, 64, which members provide a shoulder 66, 68 at the junction with their respective connecting element 54, 56 of a height substantially identical to the thickness of the tubular strut such that the outer surface of the body members 62, 64 provides a substantially smooth transition from the outer surfaces of the frame struts to the outer surface of the hinge 32-36, as can be seen in Figure 3.

The hinge half 50 includes an inner tubular section 70 which provides a shoulder 72 which itself is at the base of a tubular recess 74.

The hinge half 52 includes an inner annular wall 76 circumscribing an annular boss 78, which boss is provided with a round aperture 80 therein. Coupling the wall 76 to the outer wall 82 of the hinge half 52 are a plurality of radially spaced strengthening ribs 82. Similar ribs may be provided in the hinge half 50 between the walls 70 and 74 and the outer wall of that hinge half.

The space between the wall 76 and the boss 78 of the hinge half 52 presents an annular base wall 84.

A hinge bush 86, made of metal or metal alloy in this embodiment, includes an annular base 88 and an upstanding annular wall 90 which is provided with a plurality of radially spaced longitudinally extending ribs 92. The annular base 88 of the hinge bush 86 fits into the recess formed by the wall 76 and boss 78 of the hinge half 52 and when assembled touches in rotatable manner the base wall 84, as best seen in Figure 3. The upstanding annular wall 90, on the other hand is an interference fit into the annular wall 70 of the hinge half 50 and in practice rotates with that hinge half.

The assembly includes a washer 94 which, when fitted, sits on the shoulder 72 and which provides an upper stop to the position of the upstanding wall 90 of the bush 86. A screw fixing, in this example a button head screw 96 fits through the aperture 98 of the washer 94 and, in the preferred embodiment, engages with threads of threaded aperture 80 in the boss 78 of the hinge half 52. In other embodiments, the screw 96 has an internally threaded bore (not shown) which is then fixed to a bolt fitted into the boss 78 from the underside of the hinge half 52 when viewed in the orientation of Figure 2.

The washer 94, in combination with the screw 96, acts to urge the bush 86 against the base wall 84 of the hinge half 52, for which the upstanding wall 90 is designed to be suitably high, thereby ensuring a consistent and reliable contact and thus in practice a reliable electrical connection between the two hinge halves 50, 52. Of course, since all the components of the hinges 32-36 are preferably of conductive material, a plurality of conductive paths is typically present, thereby ensuring a good electrical connection during all the positions of the hinge.

Should it be considered necessary, there could be provided an electrically conductive sprung element within the hinge assembly. In one embodiment, there is provided a coil spring, which would fit around the upstanding wall 90 of the bushing and within the annular wall 70, of such dimensions that it is compressed against the inner surface of annular wall 76 of the hinge half 52 and against the inner surface of a similar wall (not shown) in the hinge half 50, in a manner which would be immediately apparent to a person skilled in the art. Alternatively, a Belleville spring or washer could be placed between the base wall 84 of the hinge half 52 and the annular base 88 of the bush 86.

First and second cover panels 100, 102 fit over the recesses provided by the walls 74 and of the boss 78 (on the underside of the hinge half 52 when viewed in the orientation of Figure 2) to provide a smooth outer surface to the hinge assembly. These cover panels

could be of any suitable material and their coupling to the hinge body will be apparent to the skilled person, there being a variety of fixing methods known in the art.

As will be apparent from Figure 2, the two hinge halves 50, 52 nest within one another.

5 Referring now to Figure 4, there is shown a front view of the hinge of Figure 2 in assembled form. The hinge cover 100 is provided with a plurality of angle markings 104. These note the angle between the two hinge halves 50, 52 and in practice between two frame struts coupled together by the hinge 32-36, as shown in Figure 5. Such markings are useful during the assembly of the bed frame.

10 Although the hinge assemblies are shown as fitting into the bed frame sections, it is envisaged that this coupling could be reversed. For example, for frame sections which are solid, the connecting members of the hinge halves could fit over the ends of respective frame struts, which struts could be provided with ends of reduced outer dimensions to provide shoulders similar to the shoulders 66, 68 shown in Figure 2.

15 The hinge assembly and its various components could be made of a material other than metal or metal alloy as long it can conduct electricity from one frame strut to another.

CLAIMS

1. A frame assembly for a configurable bed comprising a plurality of movable frame portions formed from one or more frame struts and a hinge assembly comprising first and second hinge parts each provided with an integral connecting member, each connecting member being able to fit to respective frame struts, the hinge having an outer perimeter which presents a substantially flat surface with one or more outer surfaces of the frame struts to which it connects wherein the hinge assembly is provided with one or more angle markers operable to indicate the angle of pivoting of the hinge assembly.
2. A frame assembly according to claim 1, wherein the frame struts are tubular and the hinge connecting members are able to fit within the tubular frame struts.
3. A frame assembly according to claim 1 or 2, wherein the first and second hinge parts have internal hinge couplings.
4. A frame assembly according to claim 1, 2 or 3, wherein the hinge assembly is electrically conductive such that a conductive path is provided from one of the connecting members to the other.
5. A frame assembly according to claim 4, wherein the hinge assembly comprises an electrically conductive hinge bush provided between the first and second hinge parts.
6. A frame assembly according to claim 5, wherein the bush is an interference fit with one of the hinge parts and abuts the other hinge part.
7. A frame assembly according to claim 4, 5 or 6, comprising an electrically conductive spring element therewithin.
8. A frame assembly according to claim 7, wherein the spring element is a coil spring or a Belleville spring.
9. A frame assembly according to any one of claims 1 to 8, wherein the first and second connecting members are provided with a fastening element.

10. A frame assembly according to claim 9, wherein the fastening element is an aperture able to receive an electrically conductive rivet or other electrically conductive fastener.
11. A frame assembly according to any one of claims 1 to 10, wherein the hinge assembly comprises first and second hinge parts each provided with an integral connecting member, the hinge assembly being electrically conductive such that a conductive path is provided through the assembly from one connecting member to the other.
12. A hinge assembly including first and second hinge parts each provided with an integral connecting member, the assembly being electrically conductive such that a conductive path is provided through the assembly from one connecting member to the other, wherein the hinge assembly is provided with one or more angle markers operable to indicate the angle of pivoting of the hinge assembly.
13. A hinge assembly according to claim 12, including an electrically conductive hinge bush provided between the first and second hinge parts.
14. A hinge assembly according to claim 13, wherein the bush is an interference fit with one of the hinge parts and abuts the other hinge part.
15. A hinge assembly according to claim 12 or 13, including an electrically conductive spring element therewithin.
16. A hinge assembly according to claim 15, wherein the spring element is a coil spring or a Belleville spring.
17. A hinge assembly according to any one of claims 12 to 16, wherein the first and second connecting members are provided with a fastening element.
18. A hinge assembly according to claim 17, wherein the fastening element is an aperture able to receive an electrically conductive rivet or other electrically conductive fastener.

19. A bed comprising a frame assembly according to any one of claims 1 to 11.
20. A bed comprising a hinge assembly according to any one of claims 12 to 18.

2/4

Fig.2.

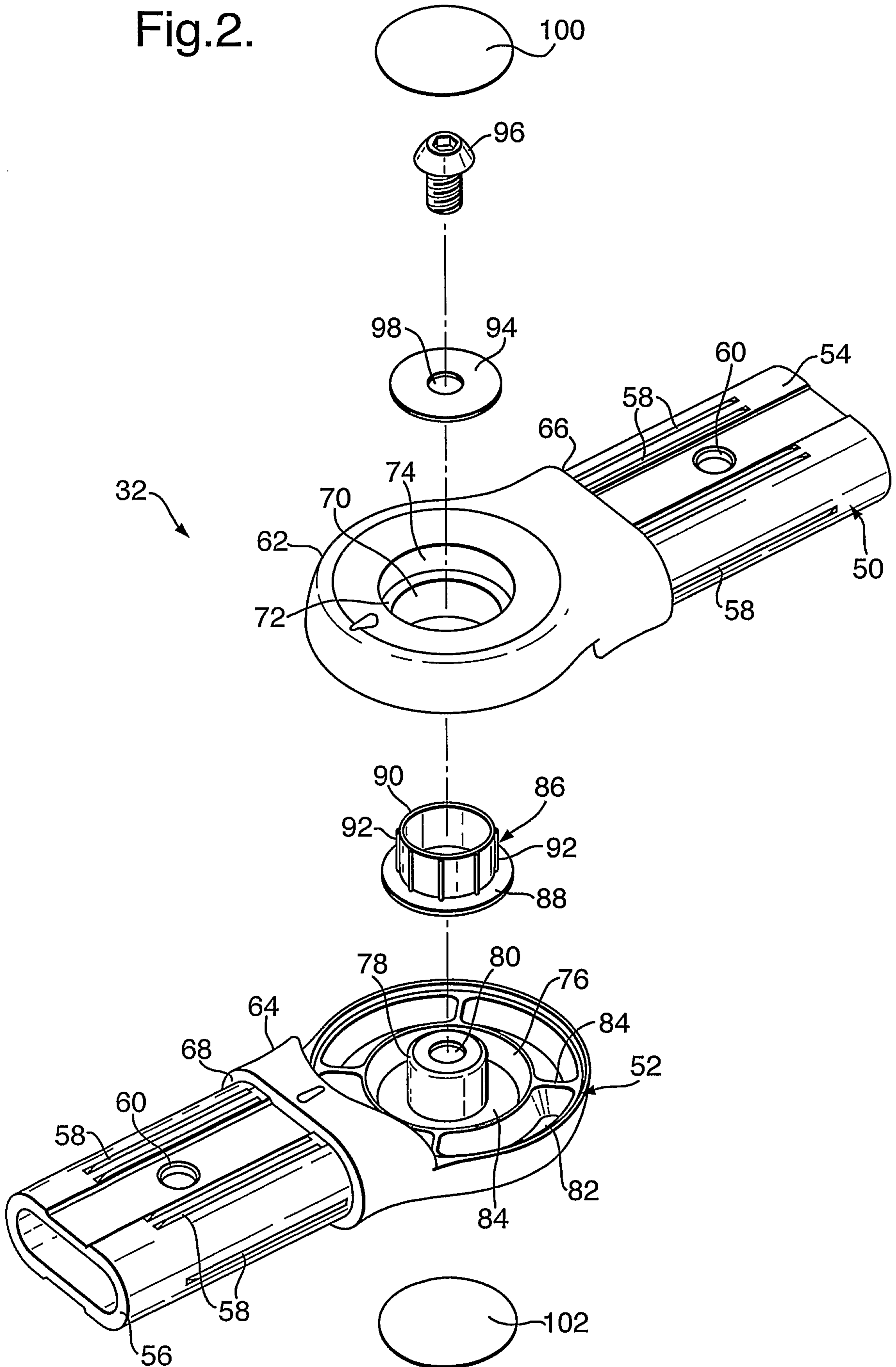

Fig.3.

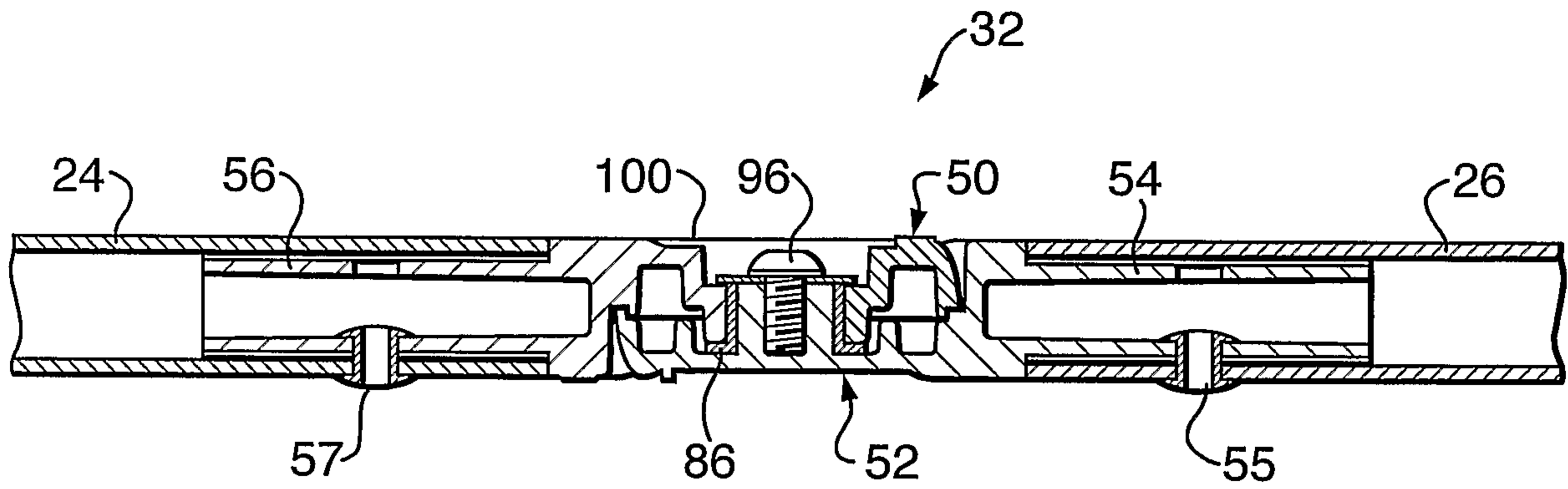

Fig.4.

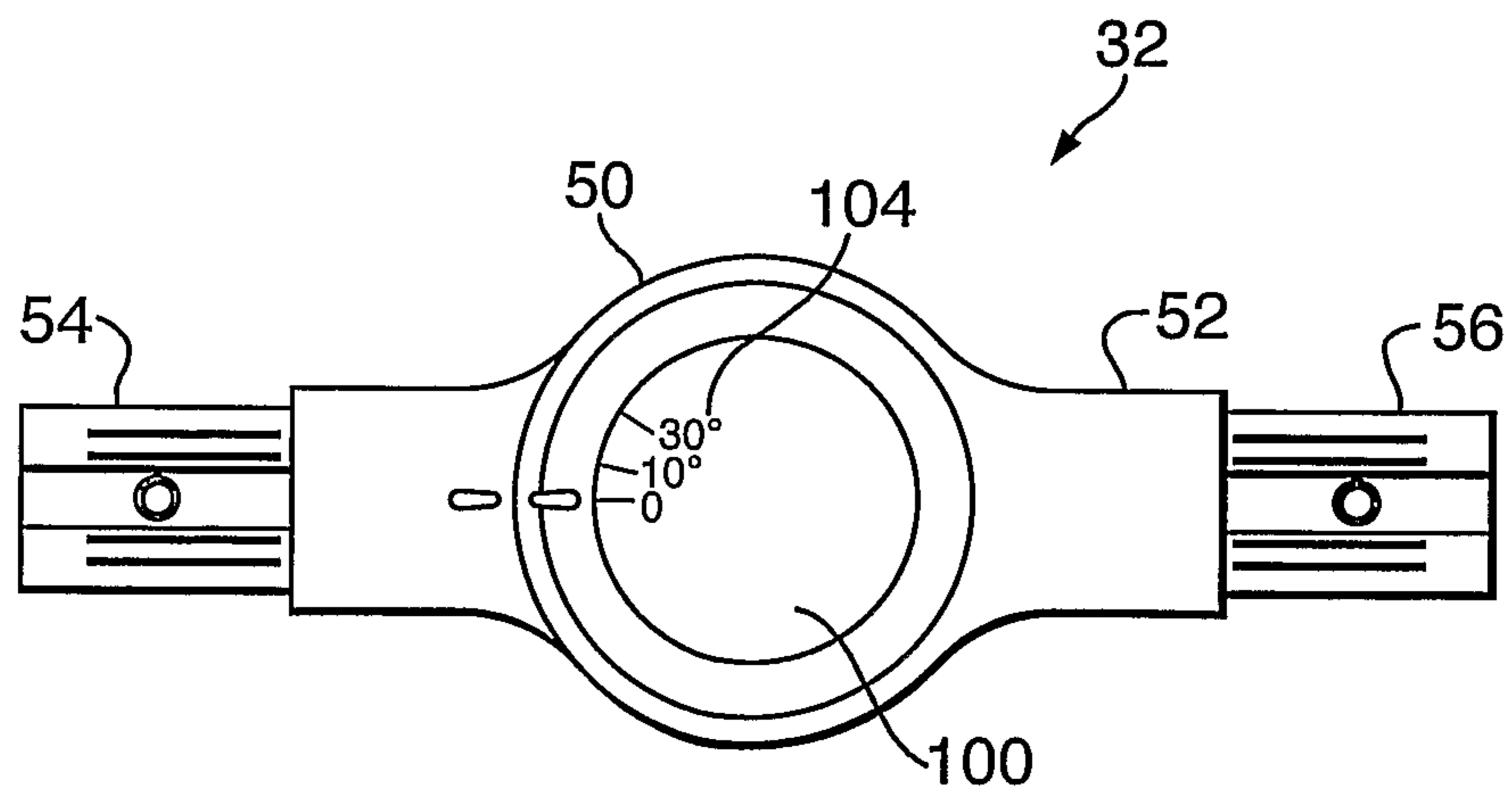

Fig.5.

