

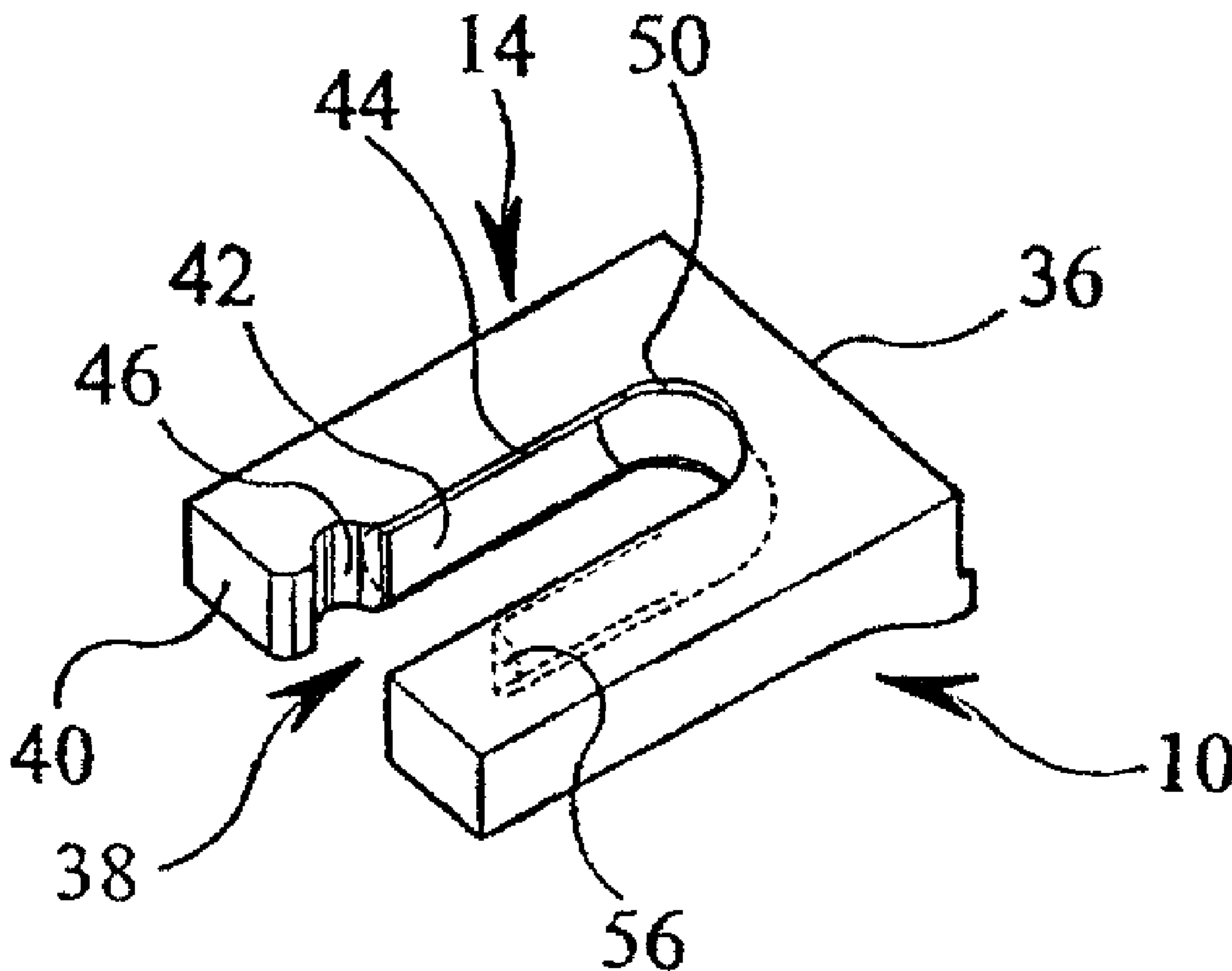

(22) Date de dépôt/Filing Date: 2004/08/12
 (41) Mise à la disp. pub./Open to Public Insp.: 2005/02/13
 (45) Date de délivrance/Issue Date: 2013/04/23
 (30) Priorités/Priorities: 2003/08/13 (GB0318995.8);
 2004/05/05 (GB0409966.9)

(51) Cl.Int./Int.Cl. *E02F 9/28* (2006.01),
E02F 3/38 (2006.01), *E02F 3/96* (2006.01),
E21B 10/44 (2006.01)
 (72) Inventeur/Inventor:
 RAYNER, ALISTER GORDON, GB
 (73) Propriétaire/Owner:
 AUGER TORQUE EUROPE LIMITED, GB
 (74) Agent: MARKS & CLERK

(54) Titre : DENT DE TARIERE LIBERABLE DOTEE D'UN DISPOSITIF DE RETENUE ABSORBANT LESCHOCS
 (54) Title: RELEASABLE AUGER TOOTH WITH SHOCK-ABSORBING RETAINING MEANS



(57) Abrégé/Abstract:

A releasable auger tooth for an auger comprises a slot shaped to fit a U-shaped or substantially U-shaped recess of a tooth holder element, and a tooth channel shaped to receive at least part of a shock-absorbing element and/or a wedging element. A holder element and assemblies are also provided.

ABSTRACT OF THE DISCLOSURE

- 5 A releasable auger tooth for an auger comprises a slot shaped to fit a U-shaped or substantially U-shaped recess of a tooth holder element, and a tooth channel shaped to receive at least part of a shock-absorbing element and/or a wedging element. A holder element and assemblies are also provided.

Releasable auger tooth with shock-absorbing retaining means

BACKGROUND OF THE INVENTION

This invention relates to a releasable auger tooth, holder element and assembly.

5

It is preferable that the teeth used on an auger (shown in Figure 1) are removable and replaceable. This allows for replacement of one or more of the teeth due to wear and damage without having to replace the entire shank plate. However, teeth rapidly become damaged when, for example, striking stone or other hard material, and this is especially so when the incorrect tooth is fitted. A case in point is the striking of rock or concrete when using a relatively soft earth-digging tooth.

10

In any new arrangement, backwards compatibility with existing tools and machinery is always a preferred option.

15

The present invention therefore seeks to provide a solution to the rapid wear and damage of auger teeth, while enabling backwards compatibility.

SUMMARY OF THE INVENTION

20

According to a first aspect of the invention, there is provided a releasable auger tooth comprising a slot shaped to fit a U-shaped or substantially U-shaped recess of a tooth holder element, and a tooth channel shaped to receive at least part of a shock-absorbing element and/or a wedging element.

In one embodiment, the tooth channel is formed in the wall defining the slot of the tooth. In one embodiment, the longitudinal extent of the tooth channel is U-shaped or substantially U-shaped. In one embodiment, the releasable auger tooth further comprises an opening in which a pin element can be inserted to releasably engage the tooth with the holder element. In one embodiment, the pin element opening is spaced from the channel. In one embodiment, the releasable auger tooth further comprises a tooth recess formed in the tooth channel, the tooth recess, in part, enabling releasable engagement of the tooth with the holder element. In one embodiment, the tooth channel is an open-ended channel. In one embodiment, the tooth channel is a closed-ended channel.

10

According to a second aspect of the invention, there is provided an auger tooth holder element for holding an auger tooth in accordance with the first aspect of the invention, the holder element comprising a U-shaped or substantially U-shaped holder element recess in which the tooth is receivable, and a holder element channel shaped to receive at least part of a shock-absorbing element.

15

In one embodiment, the holder element channel is formed in a bottom surface of the holder element recess. In one embodiment, the longitudinal extent of the holder element channel is U-shaped or substantially U-shaped. In one embodiment, the holder element further comprises a pin element aperture in which a pin element can be inserted to releasably engage the tooth and the holder element. In one embodiment, the pin element aperture is spaced from the holder element channel. In one embodiment, the holder element recess includes an occlusion which, in part, enables releasable engagement of the tooth with the holder element.

20

According to a third aspect of the invention, there is provided an auger tooth assembly comprising a releasable auger tooth in accordance with the first aspect of the invention, a holder element in accordance with the second aspect of the invention, and a shock-absorbing element which, when the tooth is received in the recess of the holder element, at least in part prevents shock imparted to the tooth from being transmitted to the holder element.

Preferably, the tooth assembly further comprises a pin element which, when the tooth is received in the recess of the holder element, prevents or limits unintentional separation of the tooth and the holder element.

According to a fourth aspect of the invention, there is provided an auger tooth assembly comprising a releasable auger tooth in accordance with the first aspect of the invention, a holder element in accordance with the second aspect of the invention, and a shock-absorbing element which, when the tooth is received in the recess of the holder element, at least in part prevents shock imparted to the tooth from being transmitted to the holder element, the shock-absorbing element also acting as a wedging element to prevent or limit unintentional separation of the tooth and holder element.

In one embodiment, the shock-absorbing element is a flexible elongate element.
In one embodiment, the shock-absorbing element is formed from rubber

According to a fifth aspect of the invention, there is provided an auger tooth assembly comprising a releasable auger tooth in accordance with the first aspect of the invention; an auger tooth holder element comprising a U-shaped or substantially U-

3a

shaped holder element recess in which the tooth is receivable, and a through-hole which
breaks out at two spaced locations in the recess; and a flexible elongate wedging
element locatable in the through-hole, the wedging element preventing or limiting
unintentional separation of the tooth and the holder element when the tooth is received
5 in the recess of the holder element.

Preferably, the wedging element is formed from rubber.

According to a sixth aspect of the invention, there is provided an excavating auger comprising a shank plate and a plurality of auger tooth assemblies in accordance with the third, fourth or fifth aspects of the invention.

5 In another aspect, the invention provides an auger tooth assembly comprising a releasable auger tooth including a slot shaped to fit a U-shaped or substantially U-shaped recess of a tooth holder element, and a tooth channel shaped to receive at least part of a shock-absorbing element, a holder element including a U-shaped or substantially U-shaped holder element recess in which the tooth is receivable, and a holder element
10 channel shaped to receive at least part of a shock-absorbing element, and a shock-absorbing element which, when the tooth is received in the recess of the holder element, at least in part prevents shock imparted to the tooth in at least a direction perpendicular to a leading edge of the tooth and towards the holder element from being transmitted to the holder element.

15 In another aspect, the invention provides an auger tooth assembly comprising a releasable auger tooth including a slot shaped to fit a U-shaped or substantially U-shaped recess of a tooth holder element, and a tooth channel shaped to receive at least part of a shock absorbing element, a holder element including a U-shaped or substantially U-shaped holder element recess in which the tooth is receivable, and a holder element
20 channel shaped to receive at least part of a shock-absorbing element, and a shock-absorbing element which, when the tooth is received in the recess of the holder element, at least in part prevents shock imparted to the tooth in at least a direction perpendicular to a leading edge of the tooth and towards the holder element from being transmitted to the holder element, the shock absorbing element also acting as a wedging element to prevent
25 or limit unintentional separation of the tooth and holder element.

4a

In another aspect, the invention provides an auger tooth assembly comprising a holder element, a tooth, a shock absorbing element, and means for releasably engaging the holder element and the tooth, the shock-absorbing element, when the tooth is held by the holder element, being interposed between the tooth and the holder element to at least in part prevent shock imparted to the tooth in at least a direction perpendicular to a leading edge of the tooth and towards the holder element from being transmitted to the holder element.

In another aspect, the invention provides a releasable auger tooth comprising a slot shaped to fit a V-shaped or substantially V-shaped recess of a tooth holder element, and a tooth channel in a rear wall of the tooth which is shaped to receive at least part of a shock absorbing element, so that, when the tooth is held by the holder element, the shock absorbing element is interposed between the tooth and the holder element to at least in part prevent shock imparted to the tooth in at least a direction perpendicular to a leading edge of the tooth and towards the holder element from being transmitted to the holder element.

The invention will now be more particularly described, by way of example, with reference to the accompanying drawings.

20

BRIEF DESCRIPTION OF THE DRAWINGS

Figure 1 shows a side view of the end of a known auger with shank plate and prior art holder elements, the teeth having been removed;

Figure 2 is a side elevational view of a holder element of a first embodiment of

4b

an auger tooth assembly and which is in accordance with the second aspect of the invention;

Figure 3 is a plan view of the holder element shown in Figure 2;

5 Figure 4 is a perspective view of an auger tooth of the first embodiment of the auger tooth assembly and which is in accordance with the first aspect of the invention;

Figure 5 is another perspective view of the tooth shown in Figure 4;

Figure 6 is a plan view of the tooth shown in Figure 4;

10 Figure 7 is a side view of a shock-absorbing element of the first embodiment of the auger tooth assembly, and which is also a wedging element of a second embodiment of an auger tooth assembly and a shock-absorbing / wedging element of a third embodiment of an auger tooth assembly;

Figure 8 is an end view of the shock-absorbing / wedging element shown in Figure 7;

Figure 9 is a perspective view of a prior art holder element;

Figure 10 is a side elevational view of the holder element shown in Figure 9;

Figure 11 is a perspective view of an auger tooth holder element of the third embodiment of the auger tooth assembly, in accordance with the second aspect of the invention;

Figure 12 is a perspective view of a releasable auger tooth of the third embodiment of the auger tooth assembly and which is in accordance with the first aspect of the invention; and

Figure 13 is a perspective view of a further embodiment of an auger tooth, in accordance with the first aspect of the invention.

DESCRIPTION OF THE PREFERRED EMBODIMENTS

Referring firstly to Figures 2 to 8 of the drawings, there is shown, in part, a first embodiment of an auger tooth assembly 10 which comprises a holder element 12, a tooth 14, a shock-absorbing element 16, and means for releasably engaging the holder element 12 and the tooth 14.

The holder element 12 is typically formed from cast alloy steel and includes a first portion 18 for welding to a shank plate 20 of an excavating auger 22 (see Figure 1, which shows an example of a typical auger) and a second portion 24 which receives the tooth 14. The second portion 24 has a U-shaped, or substantially U-shaped, recess 26 formed generally in the plane of the longitudinal extent of the holder element 12, and a U-shaped, or substantially U-shaped, channel 28 is formed in the bottom wall 30 of the

recess 26. The longitudinal extent of the channel 28 extends in parallel, or substantially in parallel, to the longitudinal extent of the recess 26.

The second portion 24 of the holder element 12 also includes an aperture 32 which forms part of the releasable engaging means and which passes entirely through the second portion 24 at right angles, or transversely, to the longitudinal extent of the recess 26. The aperture 32 partially breaks out into the recess 26, and is dimensioned to receive a known type of pin element. The pin element (not shown) forms another part of the releasable engaging means.

10

The tooth 14 is also typically formed from cast alloy steel and, depending on requirements, may include tungsten carbide claws 34 formed on the leading edge 36.

A slot 38 is formed in the trailing edge 40 of the tooth 14. The slot 38 defines two leg portions 39. The slot 38 and the leg portions 39 allow the tooth 14 to be complementarily fittable in the U-shaped recess 26 of the holder element 12.

A channel 42, similar to the channel 28 of the holder element 12, is formed in the wall 44 defining the slot 38 of the tooth 14. The longitudinal extent of the tooth channel 42 extends in parallel, or substantially in parallel, with the plane in which the slot 38 lies. The tooth channel 42 is also formed in the wall 44 of the slot 38 at a position which corresponds to the position of the holder element channel 28 so that, when the tooth 14 is received in the recess 26 of the holder element 12, the tooth channel 42 and the holder element channel 28 align or substantially align. The channel 42 is closed at both ends.

The tooth 14 also includes a slightly elongate opening 46, in the form of a recess which opens out on to the upper and lower major surfaces of the tooth 14. The opening 46 is formed in the wall 44 of the slot 38 and is spaced from the channel 42. The opening 46 forms the final part of the releasable engaging means and, when the tooth 14 is held by the holder element 12, the opening 46 aligns with the aperture 32 in the second portion 24 of the holder element 12. The provision of only one holder element aperture 32 and tooth opening 46 prevents the tooth 14 from being incorrectly engaged with the holder element 12, for example by being engaged upside-down.

The shock-absorbing element 16 is a flexible elongate, typically rubber, strip which is locatable equally, or substantially equally, in both the tooth channel 42 and the holder element channel 28, so as to be interposed between the tooth 14 and the holder element 12. The shock-absorbing element is cylindrical, or substantially cylindrical, and has a typical diameter of 6 millimetres (mm), but may be of any suitable diameter, and of any suitable grade of rubber.

Providing the holder element 12 is initially empty, the shock-absorbing element 16 is first inserted into the channel 42 of the new tooth 14. The depth of the channel 42 is less than half the diameter of the shock-absorbing element 16, so that part of the transverse extent of the shock-absorbing element 16 projects therefrom.

Insertion of the shock-absorbing element 16 into the tooth channel 42 is far more convenient than trying to initially insert the shock-absorbing element 16 into the

channel 28 in the recess 26 of the holder element 12, since the holder element 12 is generally fixed by welding to the shank plate 20 of the excavating auger 22.

The tooth 14 with shock-absorbing element 16 is then slotted into the recess 26
5 of the holder element 12 so that the projecting portion of the transverse extent of the shock-absorbing element 16 is, or is in part, received in the channel 28 of the holder element 12. As with the tooth channel 42, the depth of the holder element channel 28 is less than half the diameter of the shock-absorbing element 16. The blind-end of the slot
38 of the tooth 14 is thus, in a normal condition, spaced by the shock-absorbing element
10 16 from the tip 52 of the recess 26, which is adjacent the leading edge 48 of the holder element 12.

The pin element is then driven into the aperture 32 of the holder element 12 so that it passes through the slot opening 46 of the tooth 14. The tooth 14 is thus engaged
15 with the holder element 12.

If the tooth 14 is to be replaced, the pin element is simply driven back out of the aperture 32, and the tooth 14 is removed.

20 With an auger in normal use and fitted with the tooth assembly 10, the tooth 14 compresses the shock-absorbing element 16 to varying degrees as the shank plate turns, thus damping vibration and absorbing general knocks and strikes. Limited movement of the tooth 14 in the holder element 12 is facilitated by the opening 46 in the tooth slot 38

being elongate, which thus allows relative movement of the pin element along the longitudinal extent of the opening 46 when the tooth 14 moves.

The blind-end 50 of the tooth slot 38 is, under normal conditions, spaced from
5 the tip 52 of the recess 26 of the holder element 12.

If the tooth 14 strikes a particularly hard material, such as stone or rock, the generated energy from the impact is absorbed and dissipated by the tooth 14 increasingly compressing the shock-absorbing element 16. The limit of compression of
10 the shock-absorbing element 16 is reached when the blind-end 50 of the tooth slot 38 contacts the tip 52 of the recess 26 of the holder element 12, or the end of the elongate opening 46 in the tooth slot 38 contacts the pin element.

The tooth 14 described above is also backwards compatible with earlier types of
15 holder element 12'. As shown in Figures 9 and 10, the known prior art holder elements 12' forego the channel 28 of the first embodiment formed in the recess 26, but instead have a through-hole 54 formed in the bottom wall 30 of the holder element recess 26, transverse to the longitudinal extent of the holder element 12. A traditional auger tooth (not shown) has the slot 38 of the tooth 14 of the first embodiment, but is not formed
20 with the tooth channel 42.

The through-hole 54 of the earlier holder element 12' is adapted to receive a known flexible wedging element 16' (see Figures 7 and 8), which is in the form of an elongate rubber strip. The wedging element 16' is similar in appearance to the shock-

absorbing element 16 of the first embodiment, and projects from both ends of the through-hole 54 when inserted. A traditional auger tooth (not shown) is then simply urged onto the earlier holder element 12', causing the projecting ends of the wedging element 16' to be folded backwards and thus allowing the traditional tooth to be wedge
5 fit on to the earlier holder element 12'.

When using the prior art holder element 12', the shock-absorbing element 16 of the first embodiment is therefore used instead as wedging element 16'.

10 The wedging element 16' is first inserted through the through-hole 54 of the prior art holder element 12', rather than placed in the channel 42 of the tooth 14. The tooth 14 of the first embodiment is then, in a similar fashion to the prior art method, urged onto the traditional holder element 12'. This causes the wedging element 16' to fold backwards. However, in this case, the ends of the wedging element 16' then tend to
15 splay outwards into the channel 42 of the tooth 14 when the tooth 14 is fully pushed onto the prior art holder element 12'. The ends 56 (best seen in Figure 6) of the tooth channel 42 act as shoulders against which the ends 58 of the wedging element 16' press to further prevent or inhibit separation of the tooth 14 from the prior art holder element 12' and decrease relative tooth movement. The pin element can be dispensed with. In
20 this case, the wedging element 16' and the ends 56 of the channel 42 of the tooth 14 act in conjunction to form the releasable engaging means.

With reference to Figures 11 and 12, a third embodiment of an auger tooth assembly will now be described. The parts similar to the parts of the first and second embodiments bear similar references, and further description is omitted.

5 In this embodiment, the shock-absorbing element 16 or wedging element 16', shown in Figure 8, is employed not only to provide a shock-absorbing function, but also as part of the means for releasably engaging a tooth 14' with a holder element 12''. It is thus referred to as a shock-absorbing / wedging element and is referenced as 16''.

10 The holder element 12'' is formed similarly to that of the holder element 12 of the first embodiment. As such, the holder element 12'' also has the first portion (not shown) for welding to the shank plate 20 of an auger 22, and second portion 24 which receives the tooth 14'. The second portion 24 again has the U-shaped, or substantially U-shaped, recess 26 formed generally in the plane of the longitudinal extent of the
15 holder element 12'', and a U-shaped, or substantially U-shaped, channel 28' formed in the bottom wall 30 of the recess 26.

 In this embodiment, the channel 28' extends to end wall 59 of the recess 26 of the holder element 12'', and includes a single occlusion 60 formed adjacent to, but
20 spaced from, the end wall 59. The occlusion 60 does not project out of the channel 28', and forms part of the releasable engaging means. The aperture 32 of the holder element 12 and pin element are dispensed with.

The tooth 14' includes a channel 42' formed in the slot 38. The channel 42' extends around the wall 44 defining the slot 38, and breaks out on the trailing edge 40 of the tooth 14'.

5 The channel 42' includes an occlusion recess 62 adjacent to, but spaced from, the trailing edge 40 of the tooth 14'. The occlusion recess 62 of the tooth 14' and the occlusion 60 of the holder element 12'' are complementarily dimensioned. The occlusion recess 62 is positioned along the channel 42' so that it will align, or substantially align, with the occlusion 60 when the holder element 12'' and the tooth
10 14' are mated.

The occlusion recess 62 does not break out on to upper and lower major surfaces 64 and 66 of the tooth 14'. The occlusion recess 62 forms the final part of the releasable engaging means.

15

The elongate opening 46 of the tooth 14 of the first embodiment, which is intended to accept the pin element, is dispensed with.

It is intended, in this embodiment, that the shock-absorbing/wedging element
20 16'' is pre-moulded or pre-located in the channel 42' of the tooth 14' prior to the tooth 14' being supplied to the user. It is of course possible for a user to manually locate the shock-absorbing/wedging element 16'' in the channel 42' of the tooth 14'.

In any event, when the tooth 14' is separate from the holder element 12'', the shock-absorbing/wedging element 16'', when provided or located in the channel 42', simply bridges or spans the occlusion recess 62 rather than entering the occlusion recess 62.

5

In use, and with the shock-absorbing/wedging element 16'' residing in the channel 42', the tooth 14' is urged into engagement with the holder element 12'', as described previously. As the tooth 14' is pushed home, the occlusion 60 in the channel 28' of the holder element 12'' urges part of the shock-absorbing/wedging element 16'' into the adjacent occlusion recess 62 of the tooth 14'. The tooth 14' is thereby effectively locked to the holder element 12'', preventing or limiting unintentional separation.

The tooth 14' is removed from the holder element 12'' in any suitable known way, for example by knocking with a hammer and chisel.

Although only one occlusion and corresponding occlusion recess are required, more than one occlusion and corresponding occlusion recess could be provided. The provision of only one occlusion and occlusion recess aids in preventing the tooth 14' from being incorrectly engaged with the holder element 12'', for example by being engaged upside-down.

Referring to Figure 13, a further embodiment of an auger tooth is shown. This tooth 14'' differs from the tooth 14' described above in that the channel 42'' no longer

breaks out on to the trailing edge 40 of the tooth 14''. Parts which correspond to the parts of the earlier embodiments therefore share the same references, and further details are omitted.

5 The channel 42'' is therefore a closed channel, rather than the open channel of the previous embodiment. The occlusion recess 62, although not seen, is still provided.

By having the closed channel 42'', shock-absorbing/wedging element 16'', if not affixed to the tooth 14'', is prevented from separating from the tooth 14'' when the
10 tooth 14'' is removed from the holder element 12''. As the tooth 14'' is withdrawn from the recess 26 of the holder element 12'', the ends 58 of the shock-absorbing/wedging element 16'' contact the end faces 68 of the closed channel 42''. Further movement of the shock-absorbing/wedging element 16'' along the longitudinal extent of the channel 42'' is thus prevented, and the tooth 14'' can be separated from the holder element 12''
15 with the shock-absorbing/wedging element 16'' intact.

This is particularly advantageous when multiple holder elements 12'' are mounted to a shank plate in close proximity to each other, which is often the case. If the shock-absorbing/wedging element 16'' remains on the holder element 12'', it can be
20 particularly troublesome and difficult to try and then remove the element 16'' independently.

The reverse situation also holds true, and it is of particular advantage to have the shock-absorbing element 16 and shock-absorbing/wedging element 16''/16''' initially

residing on the tooth 14/14'/14'', rather than having to attempt mounting the element 16/16''/16''' initially on the holder element 12/12''.

The teeth 14'/14'' can also be used with existing holder elements, in a similar
5 manner to that described above.

The shock-absorbing element or shock-absorbing/wedging element could be
interposed between the trailing edge of the tooth and the end wall of the recess of the
holder element.
10

The shock-absorbing element and/or shock-absorbing/wedging element,
although preferably rubber, could be of any suitable shock-absorbing material. The
shock-absorbing element and/or shock-absorbing/wedging element could also have a
non-circular transverse cross-section, if necessary.
15

It is thus possible to provide an auger tooth assembly which reduces the wear
and damage caused to a tooth when in use. It is also possible to provide a tooth which is
backwards compatible with an existing holder element of a tooth assembly.

20 The embodiments described above are given by way of example only, and other
modifications will be apparent to persons skilled in the art without departing from the
scope of the invention as defined by the appended claims.

The embodiments of the invention in which an exclusive property or privilege is claimed are defined as follows:

1. An auger tooth assembly comprising a releasable auger tooth including a slot shaped to fit a U-shaped or substantially U-shaped recess of a tooth holder element, and a tooth channel shaped to receive at least part of a shock-absorbing element, a holder element including a U-shaped or substantially U-shaped holder element recess in which the tooth is receivable, and a holder element channel shaped to receive at least part of a shock-absorbing element, and a shock-absorbing element which, when the tooth is received in the recess of the holder element, at least in part prevents shock imparted to the tooth in at least a direction perpendicular to a leading edge of the tooth and towards the holder element from being transmitted to the holder element.
2. An auger tooth assembly as claimed in claim 1, further comprising a pin element which, when the tooth is received in the recess of the holder element, prevents or limits unintentional separation of the tooth and the holder element.
3. An auger tooth assembly comprising a releasable auger tooth including a slot shaped to fit a U-shaped or substantially U-shaped recess of a tooth holder element, and a tooth channel shaped to receive at least part of a shock absorbing element, a holder element including a U-shaped or substantially U-shaped holder element recess in which the tooth is receivable, and a holder element channel shaped to receive at least part of a shock-absorbing element, and a shock-absorbing element which, when the tooth is received in the recess of the holder element, at least in part prevents shock imparted to the tooth in at least a direction perpendicular to a leading edge of the tooth and towards the holder element from being transmitted to the holder element, the shock absorbing element also acting as a wedging element to prevent or limit unintentional separation of the tooth and holder element.
4. An auger tooth assembly as claimed in any one of claims 1 to 3, wherein the shock-absorbing element is a flexible elongate element.

5. An auger tooth assembly as claimed in any one of claims 1 to 4, wherein the shock-absorbing element is formed from rubber.
6. An auger tooth assembly as claimed in any one of claims 1 to 5, wherein the tooth channel is formed in the wall defining the slot of the tooth.
7. An auger tooth assembly as claimed in any one of claims 1 to 6, wherein the longitudinal extent of the tooth channel is U-shaped or substantially U-shaped.
8. An auger tooth assembly as claimed in any one of claims 1 to 7, further comprising an opening in which the pin element can be inserted to releasably engage the tooth with the holder element.
9. An auger tooth assembly as claimed in claim 8, wherein the pin element opening is spaced from the channel.
10. An auger tooth assembly as claimed in any one of claims 1 to 9, further comprising a tooth recess formed in the tooth channel, the tooth recess, in part, enabling releasable engagement of the tooth with the holder element.
11. An auger tooth assembly as claimed in any one of claims 1 to 10, wherein the tooth channel is an open-ended channel.
12. An auger tooth assembly as claimed in any one of claims 1 to 10, wherein the tooth channel is a closed-ended channel.
13. An auger tooth assembly as claimed in any one of claims 1 to 12, wherein the holder element channel is formed in a bottom surface of the holder element recess.
14. An auger tooth assembly as claimed in any one of claims 1 to 13, wherein the longitudinal extent of the holder element channel is U-shaped or substantially U-shaped.

15. An auger tooth assembly as claimed in any one of claims 1 to 14, wherein the holder element further comprises the pin element aperture in which a pin element can be inserted to releasably engage the tooth and the holder element.
16. An auger tooth assembly as claimed in claim 15, wherein the pin element aperture is spaced from the holder element channel.
17. An auger tooth assembly as claimed in any one of claims 1 to 14, wherein the holder element recess includes an occlusion which, in part, enables releasable engagement of the tooth with the holder element.
18. An auger tooth assembly comprising a holder element, a tooth, a shock absorbing element, and means for releasably engaging the holder element and the tooth, the shock-absorbing element, when the tooth is held by the holder element, being interposed between the tooth and the holder element to at least in part prevent shock imparted to the tooth in at least a direction perpendicular to a leading edge of the tooth and towards the holder element from being transmitted to the holder element.
19. A releasable auger tooth comprising a slot shaped to fit a U-shaped or substantially U-shaped recess of a tooth holder element, and a tooth channel in a rear wall of the tooth which is shaped to receive at least part of a shock absorbing element, so that, when the tooth is held by the holder element, the shock absorbing element is interposed between the tooth and the holder element to at least in part prevent shock imparted to the tooth in at least a direction perpendicular to a leading edge of the tooth and towards the holder element from being transmitted to the holder element.
20. An excavating auger comprising a shank plate and a plurality of auger tooth assemblies as defined in any one of claims 1 to 19.

FIG 1
Prior art

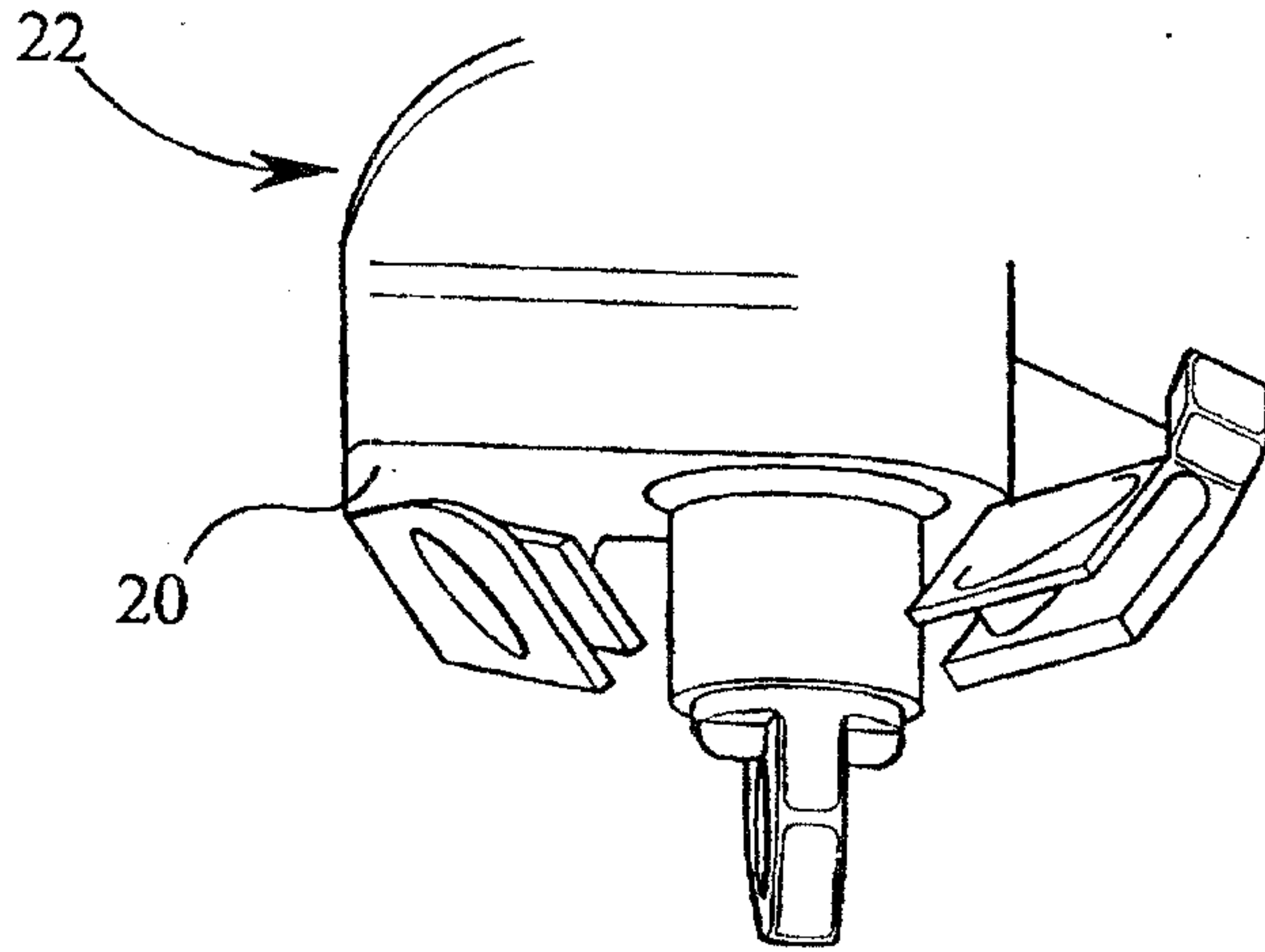

FIG 2

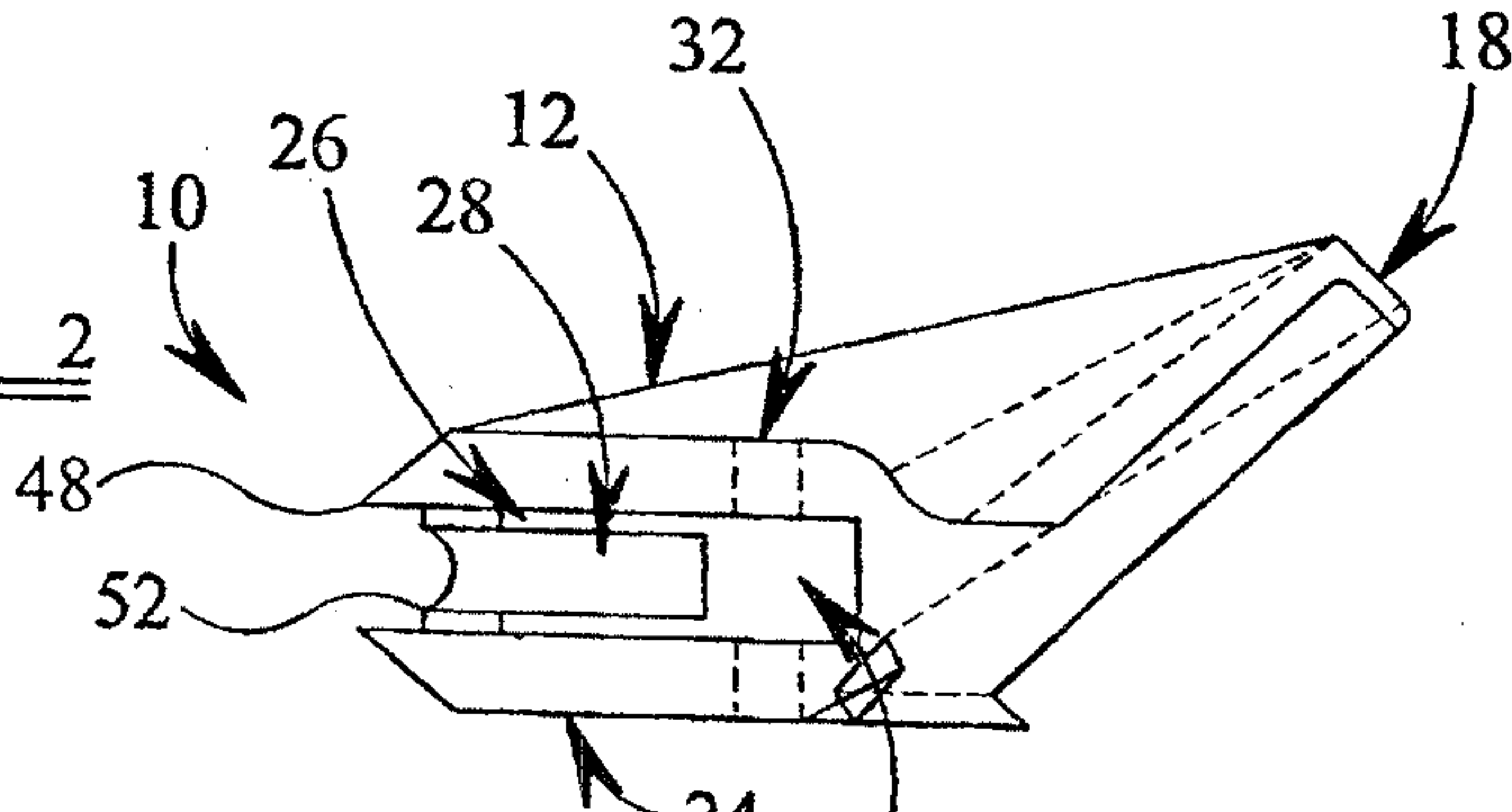

FIG 3

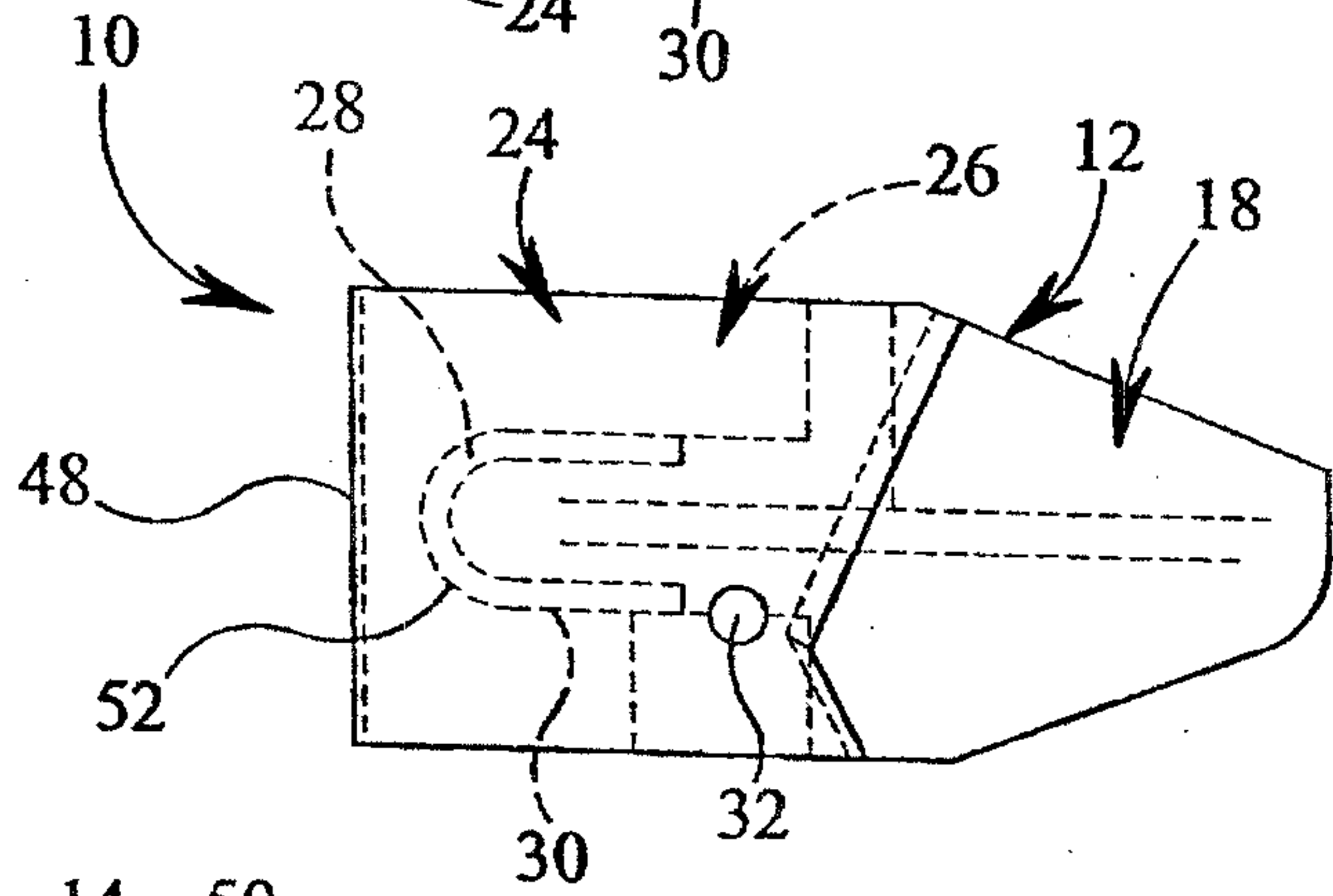

FIG 4

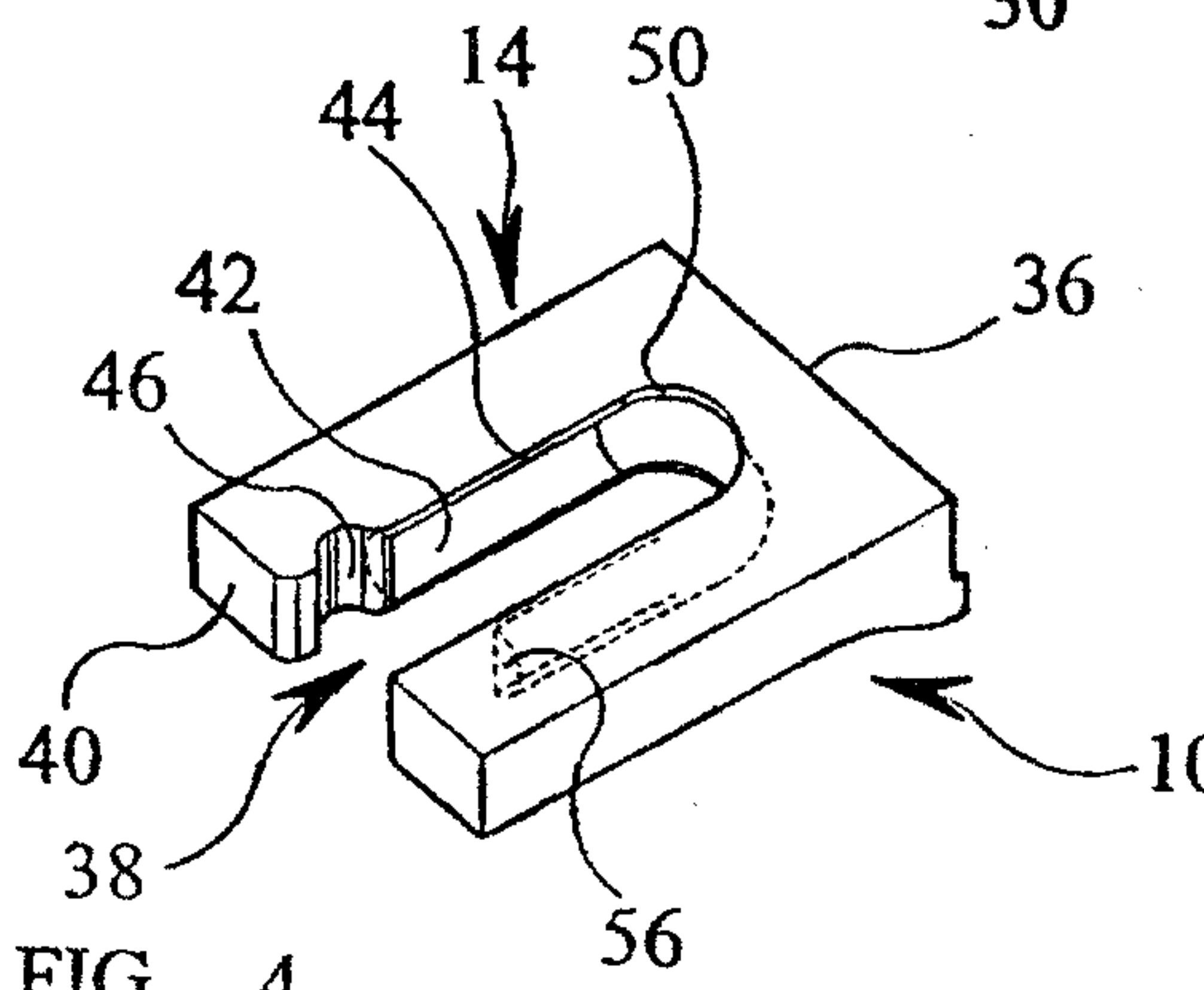
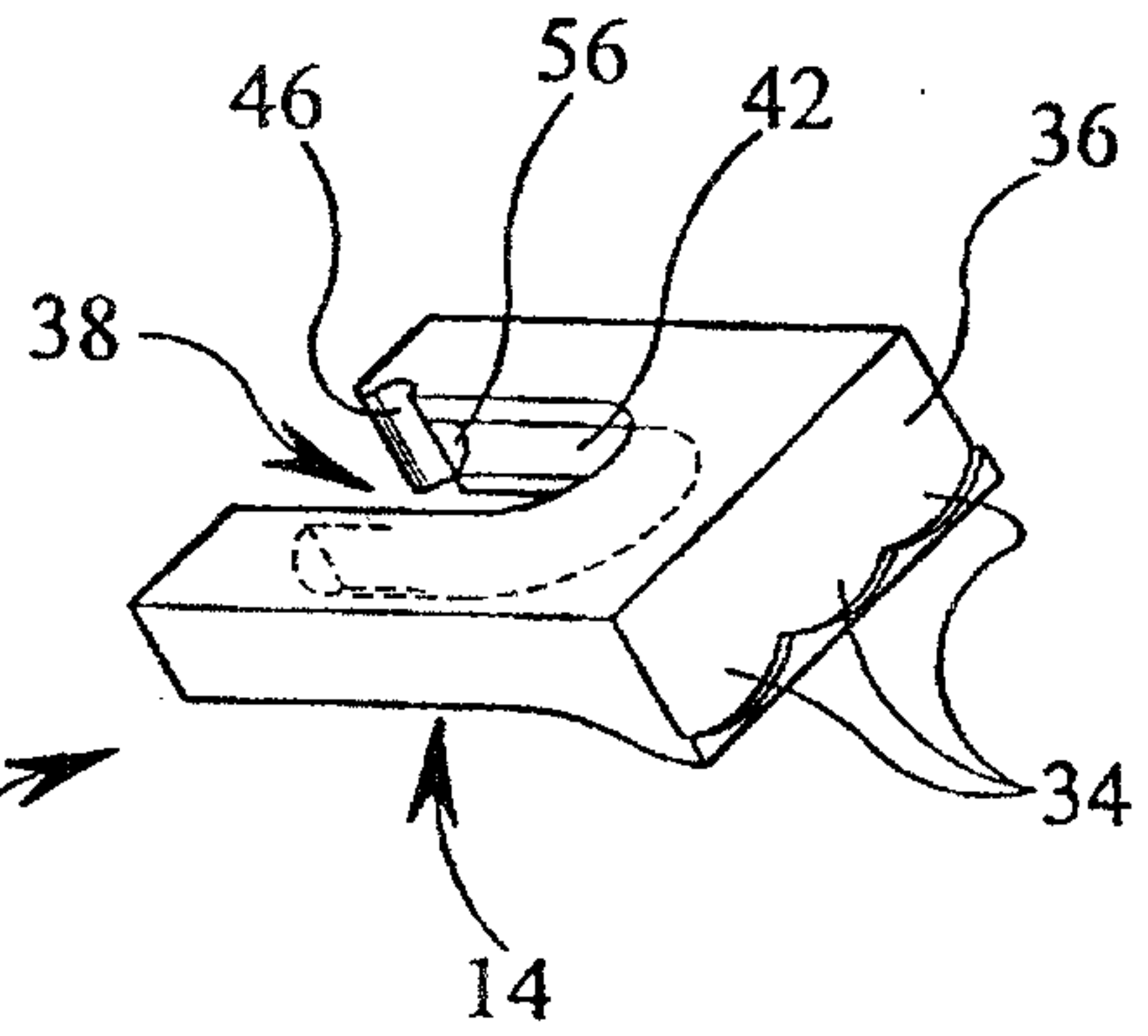
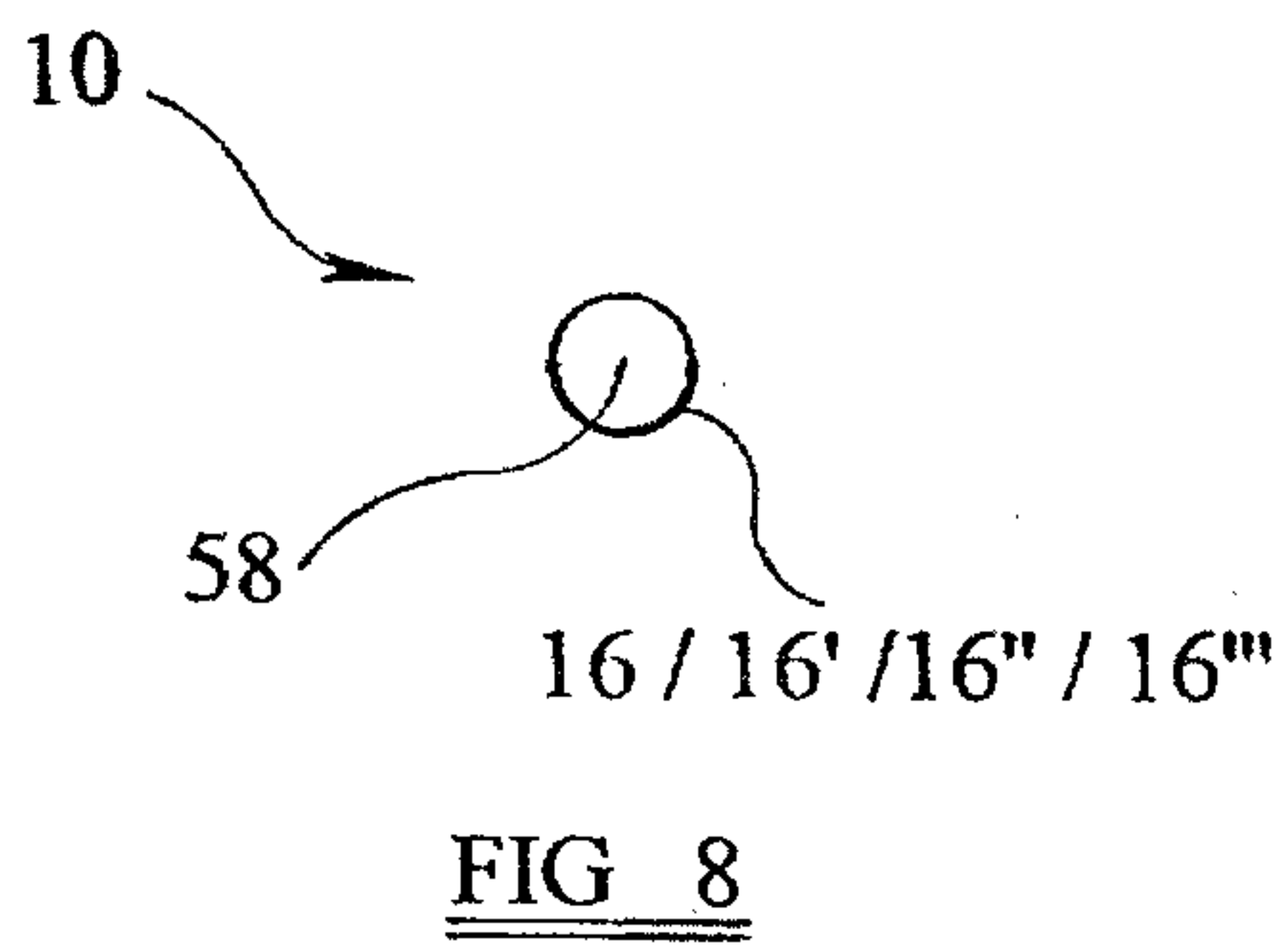
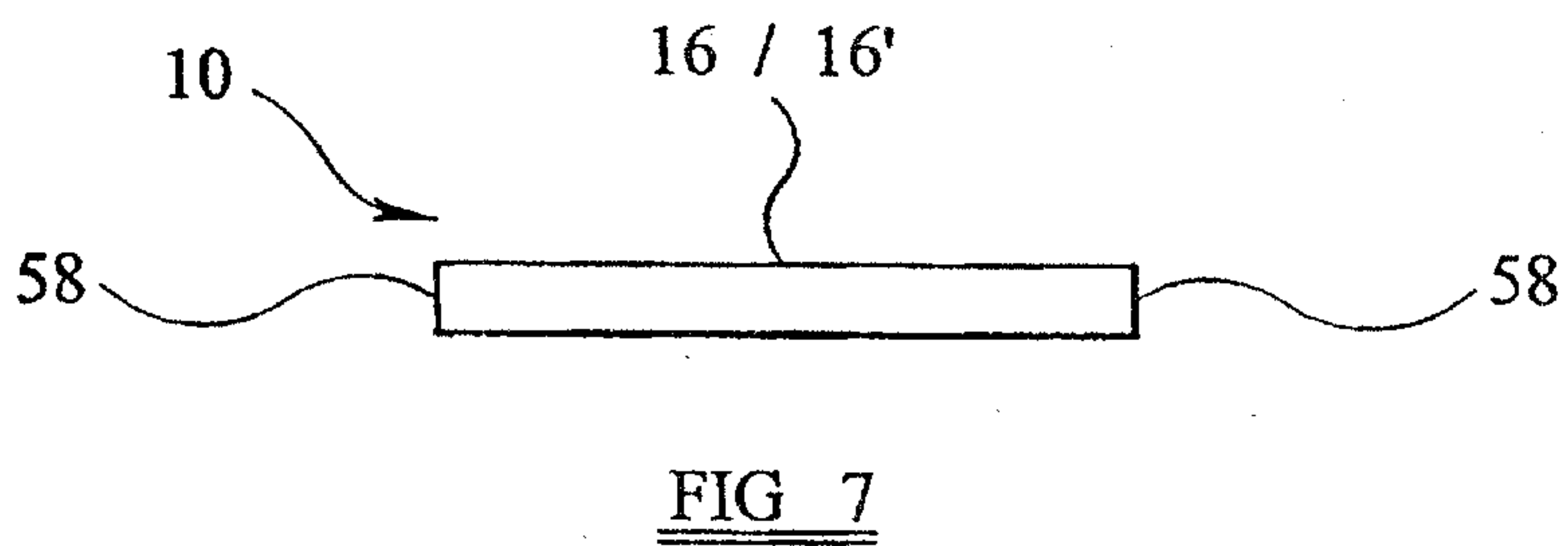
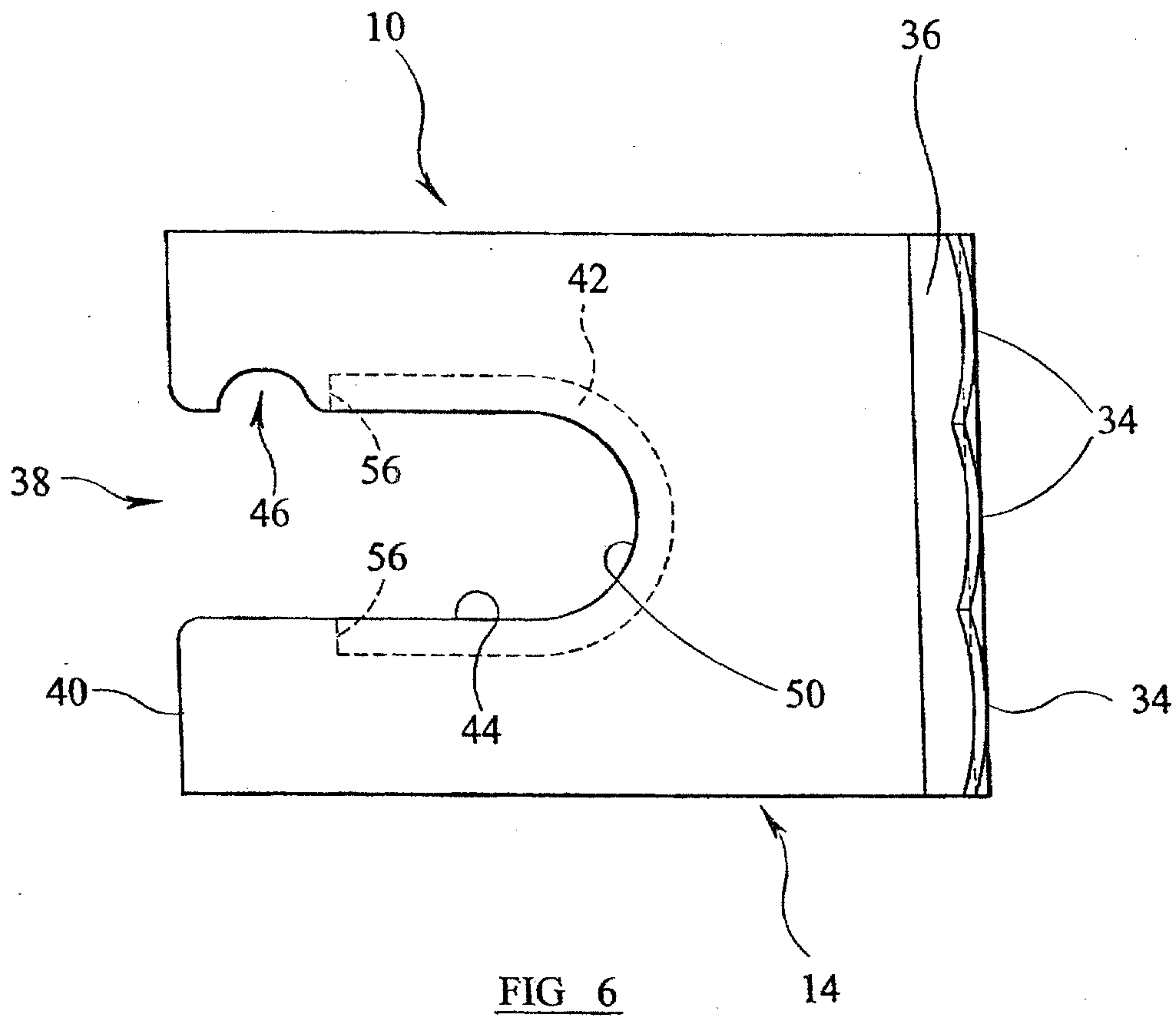

FIG 5



2 / 6



3 / 6

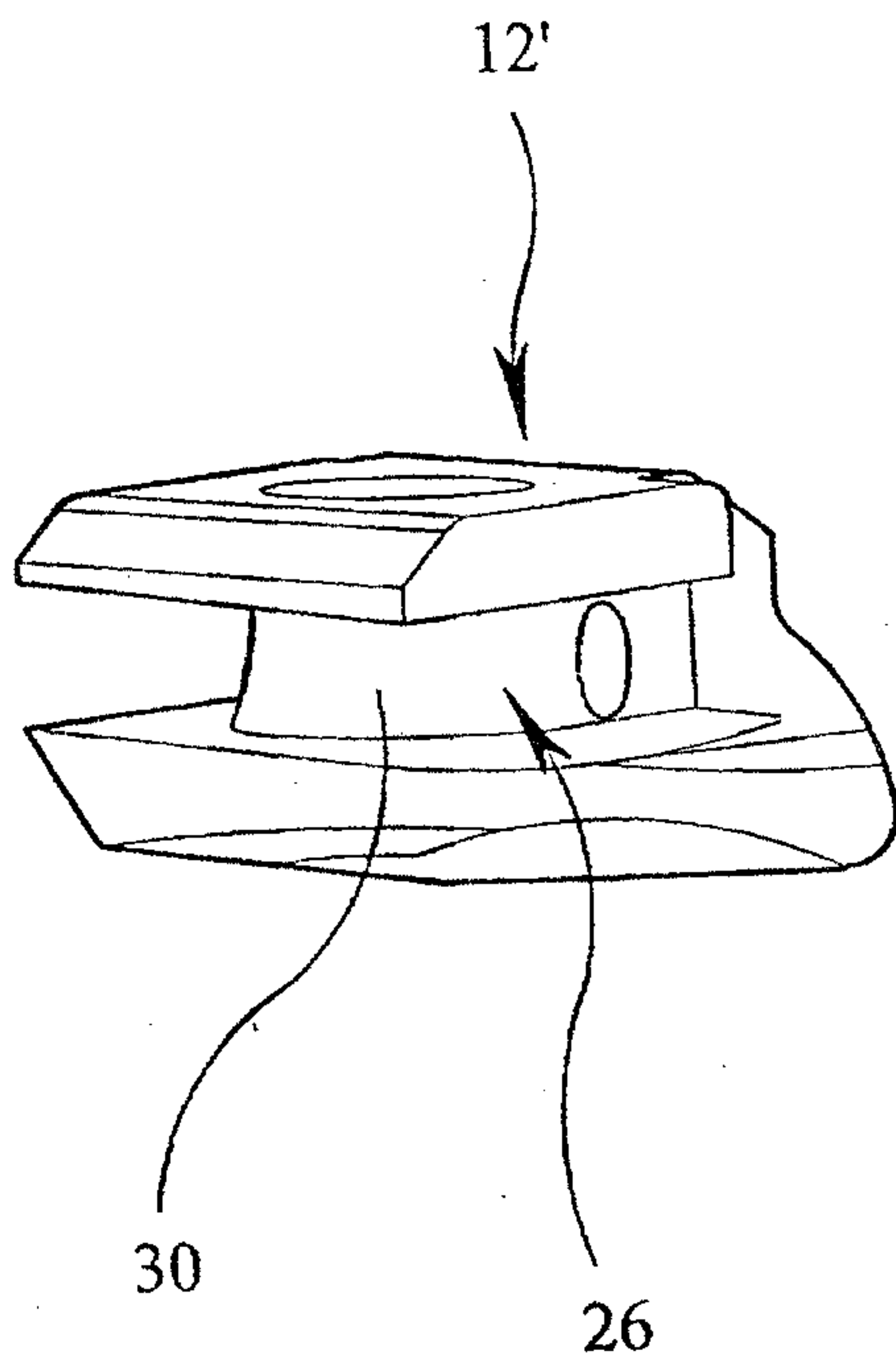

FIG 9
Prior art

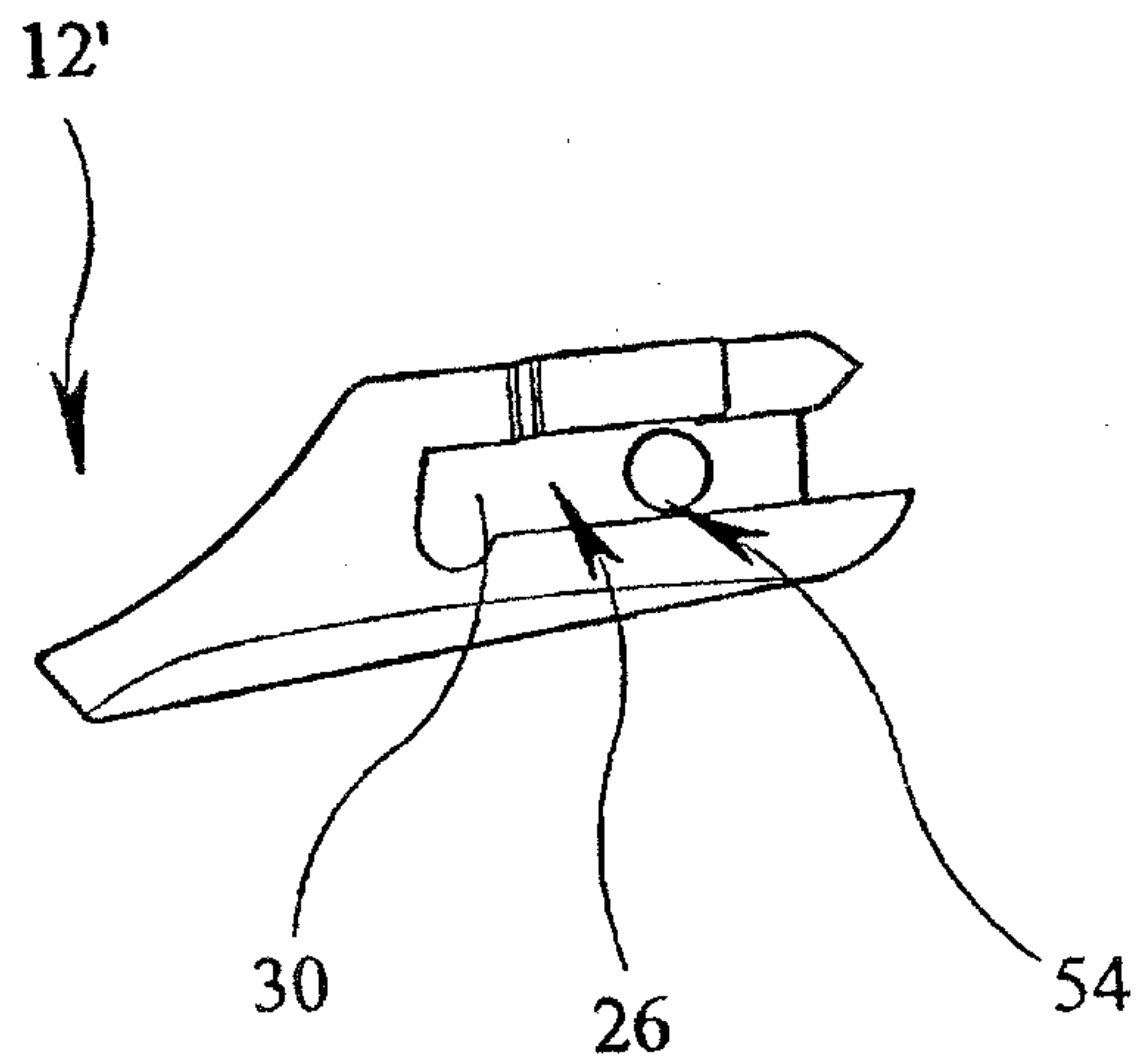

FIG 10
Prior art

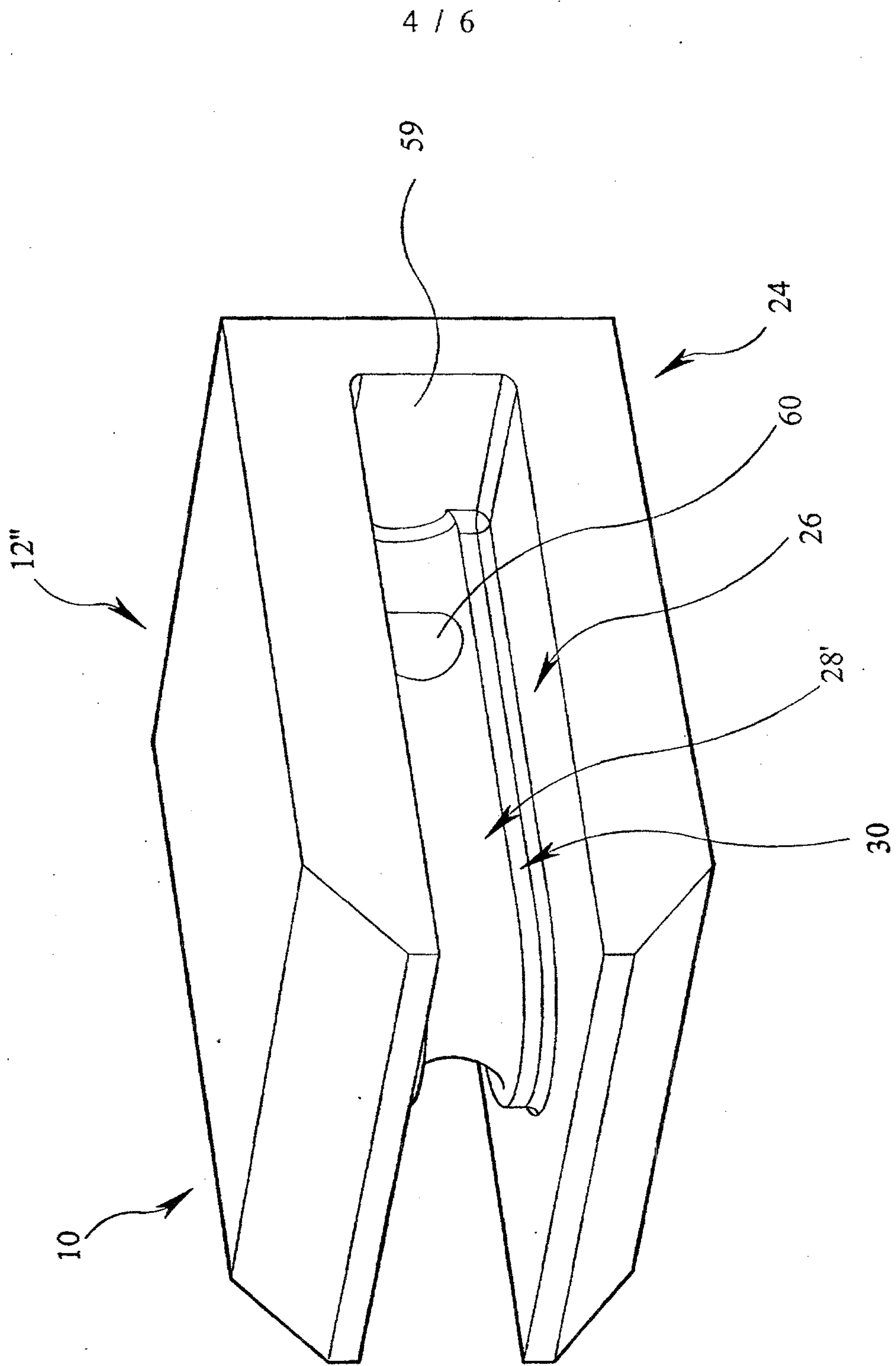

FIG 11

5 / 6

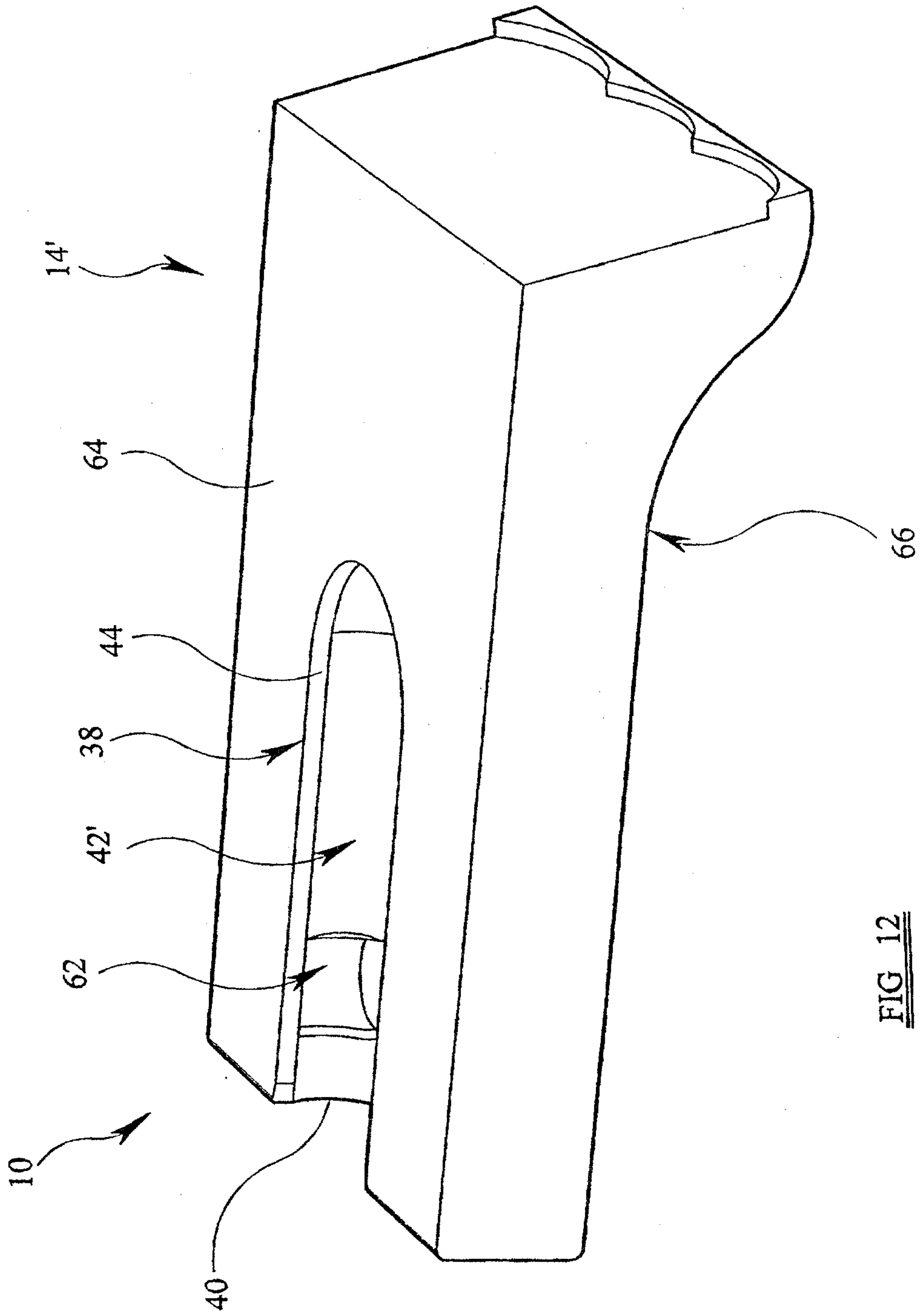

FIG 12

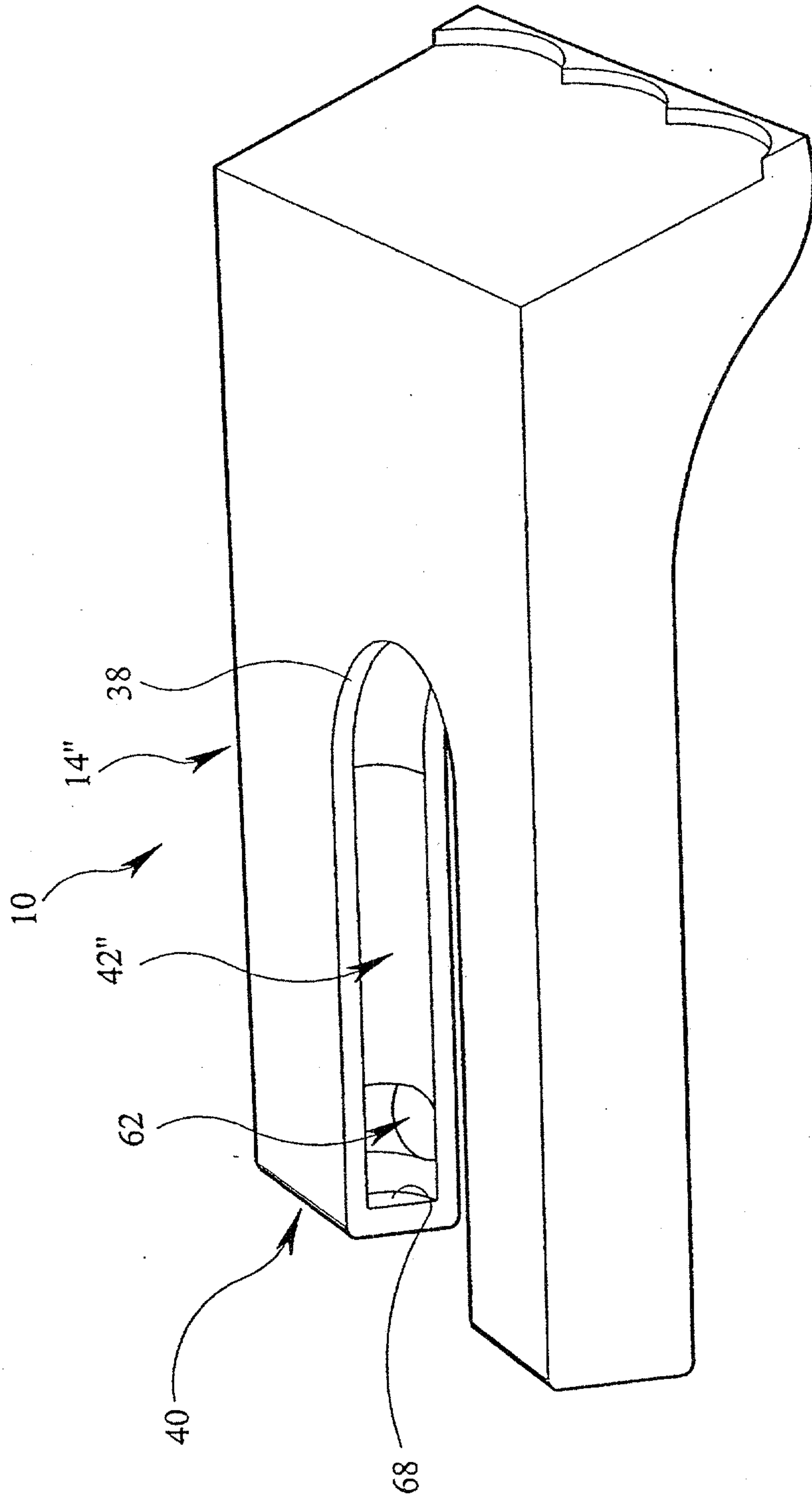

FIG 13

