



US 20140021082A1

(19) **United States**

(12) **Patent Application Publication**  
**Holley, JR.**

(10) **Pub. No.: US 2014/0021082 A1**

(43) **Pub. Date: Jan. 23, 2014**

(54) **CARTON WITH HANDLE**

**Publication Classification**

(71) Applicant: **GRAPHIC PACKAGING INTERNATIONAL, INC.**, Atlanta, GA (US)

(51) **Int. Cl.**  
**B65D 5/468** (2006.01)  
**B65D 5/44** (2006.01)

(72) Inventor: **John Murdick Holley, JR.**, Lawrenceville, GA (US)

(52) **U.S. Cl.**  
CPC ..... **B65D 5/4608** (2013.01); **B65D 5/445** (2013.01)  
USPC ..... **206/427**; 229/117.16; 493/405

(73) Assignee: **Graphic Packaging International, Inc.**, Atlanta, GA (US)

(57) **ABSTRACT**

(21) Appl. No.: **13/836,804**

A carton for holding a plurality of containers. The carton can comprise a plurality of panels that extends at least partially around an interior of the carton. At least one end flap can be foldably connected to at least one panel of the plurality of panels. The at least one end flap can at least partially form a closed end of the carton. At least one handle comprises at least one handle flap foldably connected to the at least one end flap along a first fold line. The at least one handle flap comprises a grip portion at least partially defined by the first fold line and a second fold line extending in the at least one handle flap. The first fold line and the second fold line are nonparallel.

(22) Filed: **Mar. 15, 2013**

**Related U.S. Application Data**

(60) Provisional application No. 61/797,758, filed on Dec. 14, 2012, provisional application No. 61/741,314, filed on Jul. 17, 2012, provisional application No. 61/741,315, filed on Jul. 17, 2012.

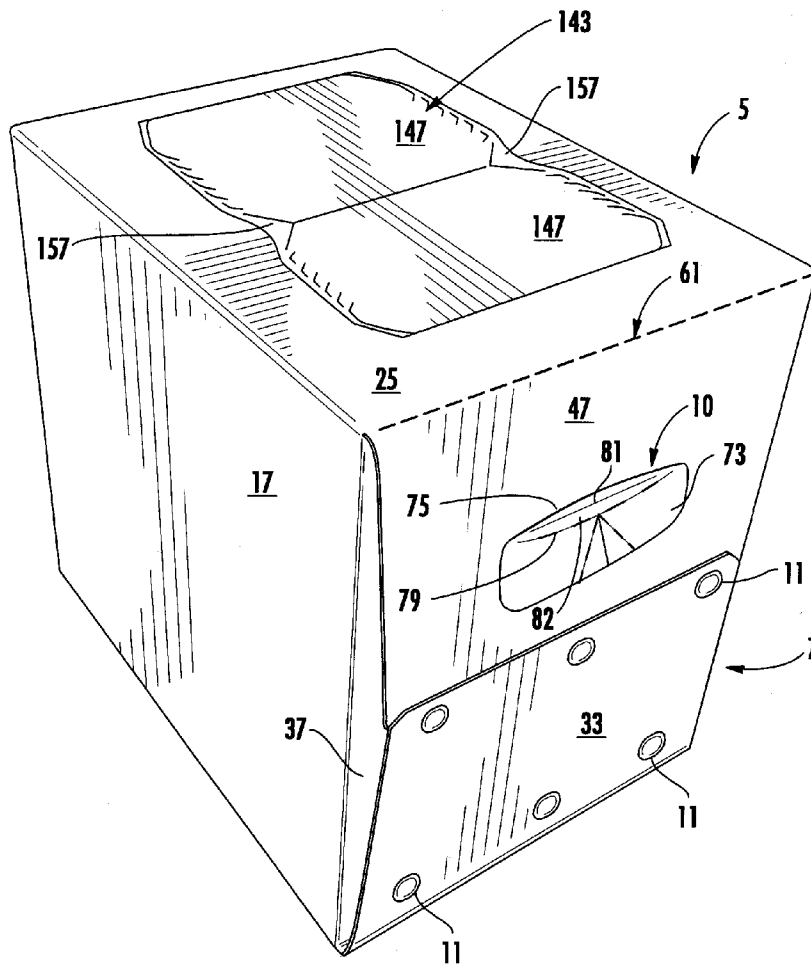

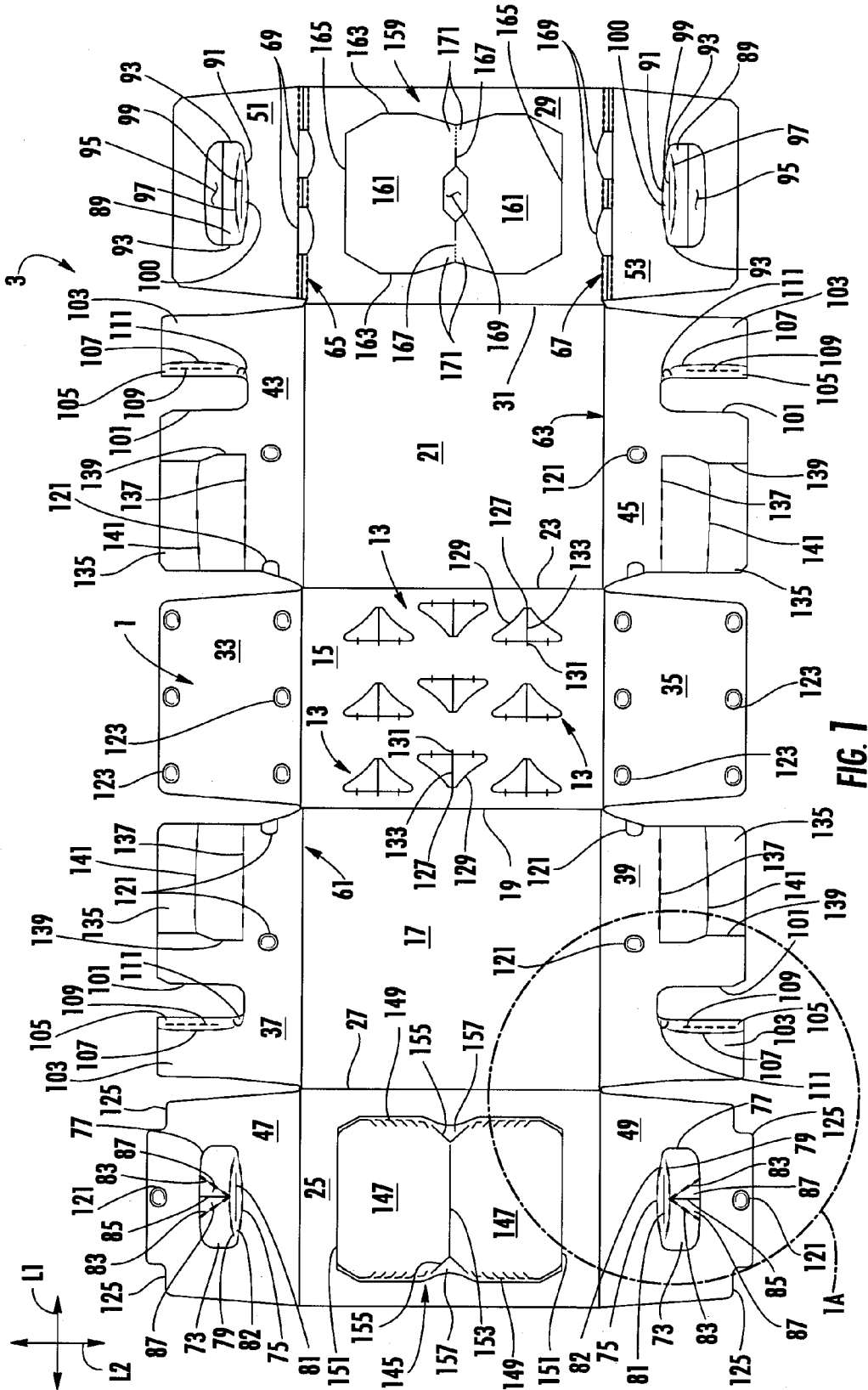

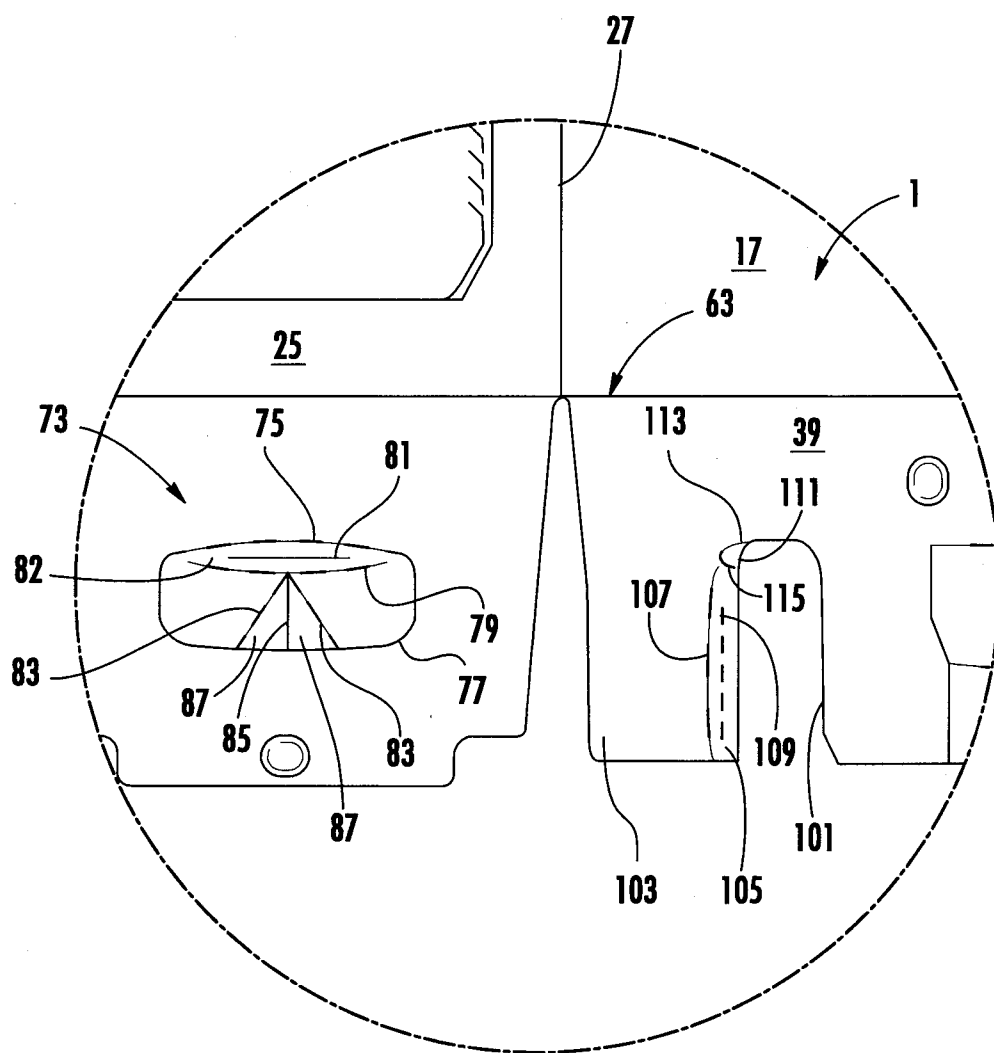

FIG. 1A

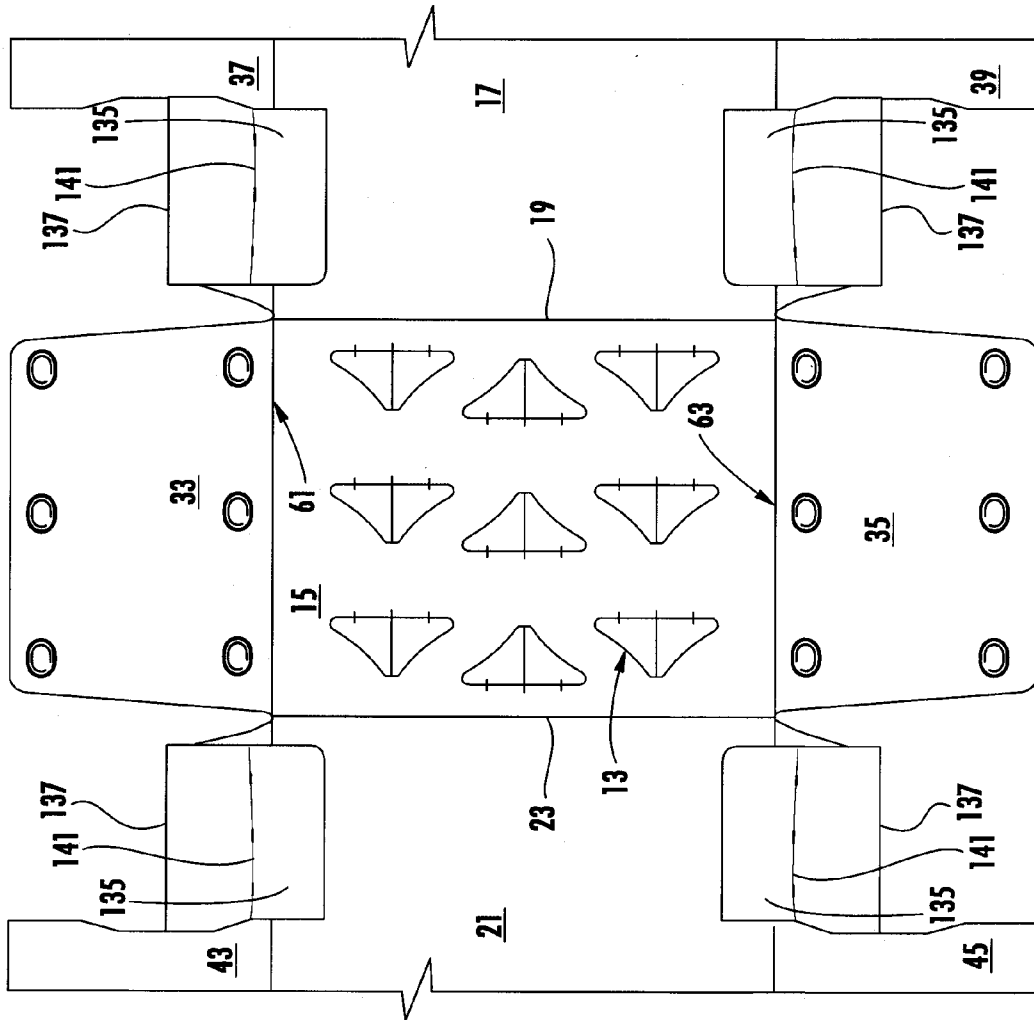

FIG. 2

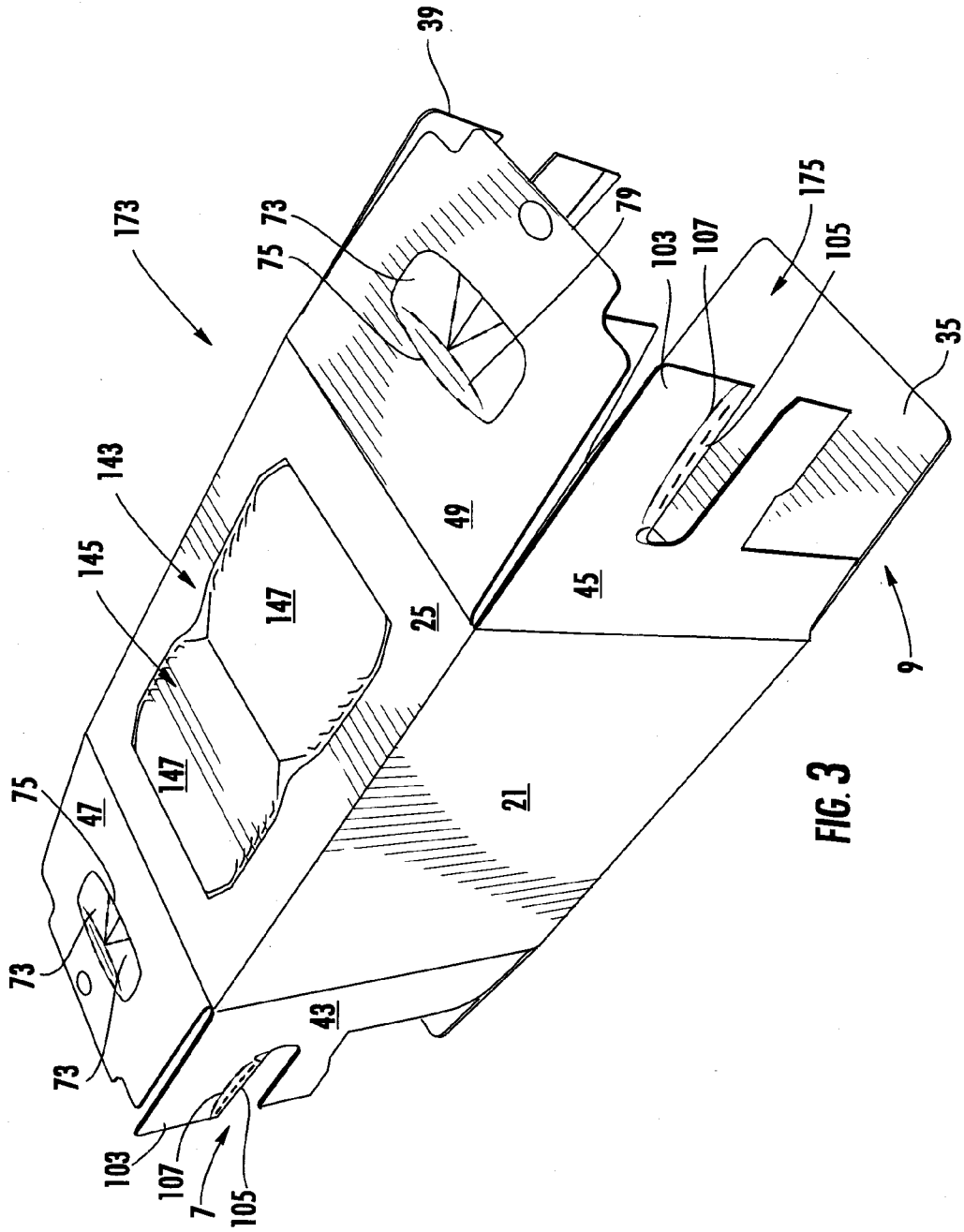

FIG. 3

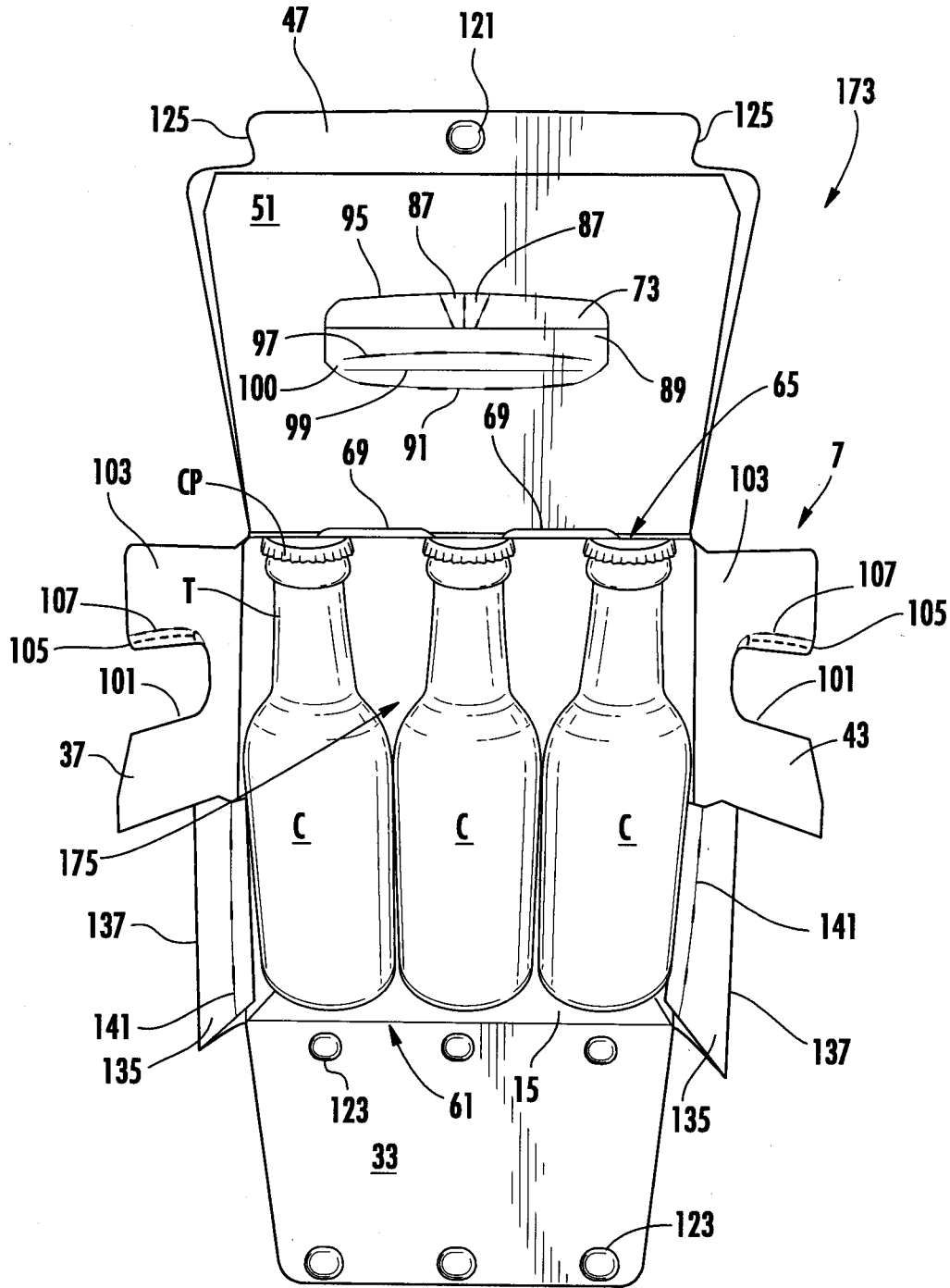
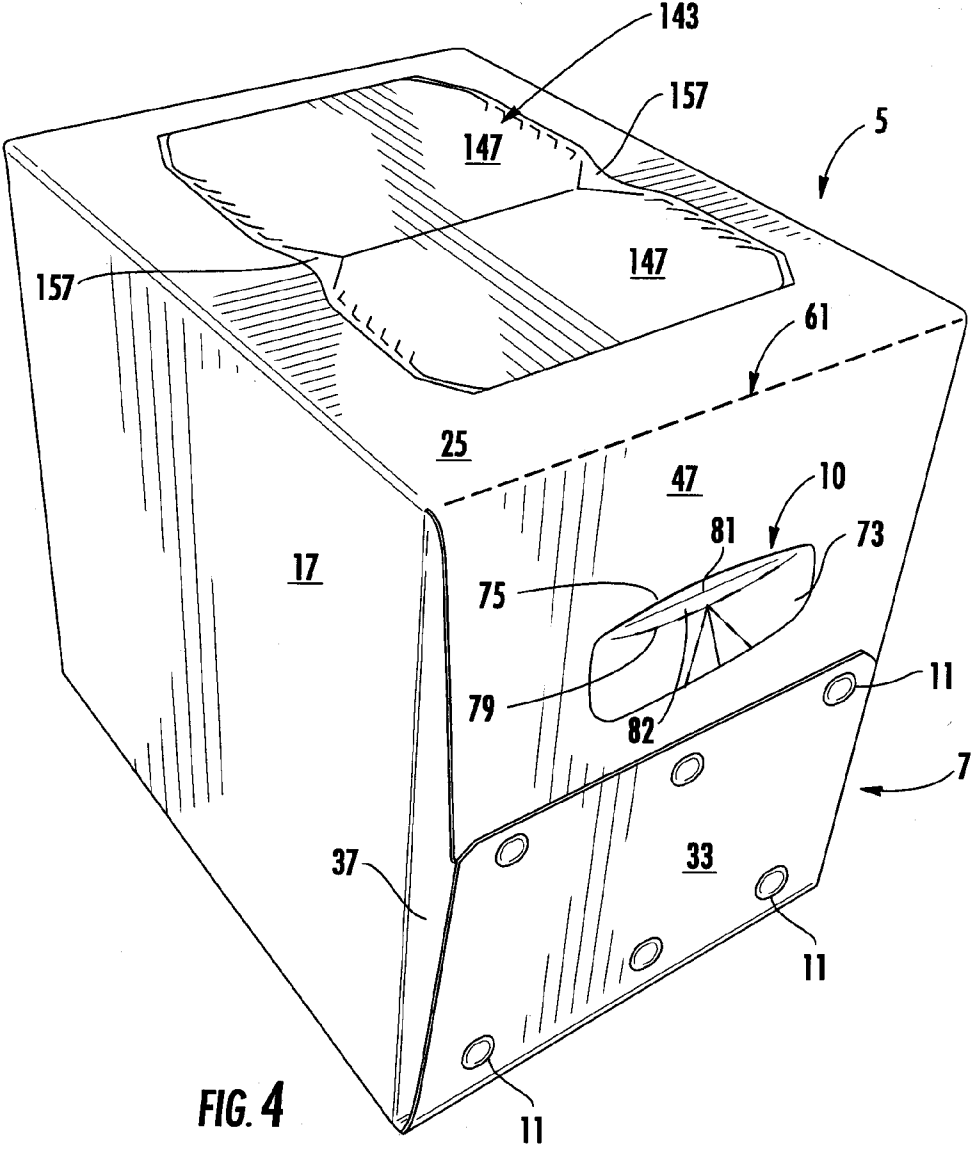

FIG. 3A



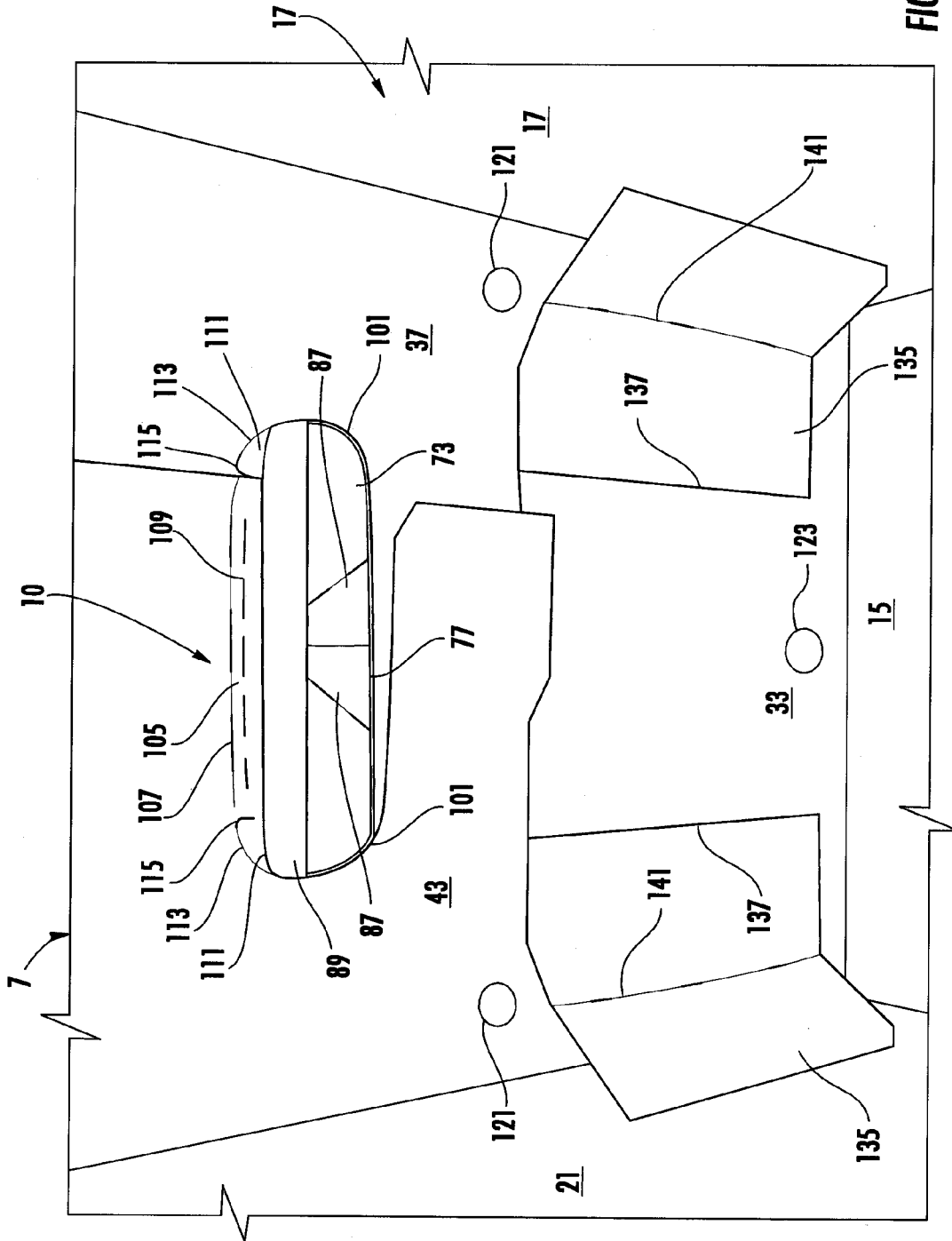

FIG. 5

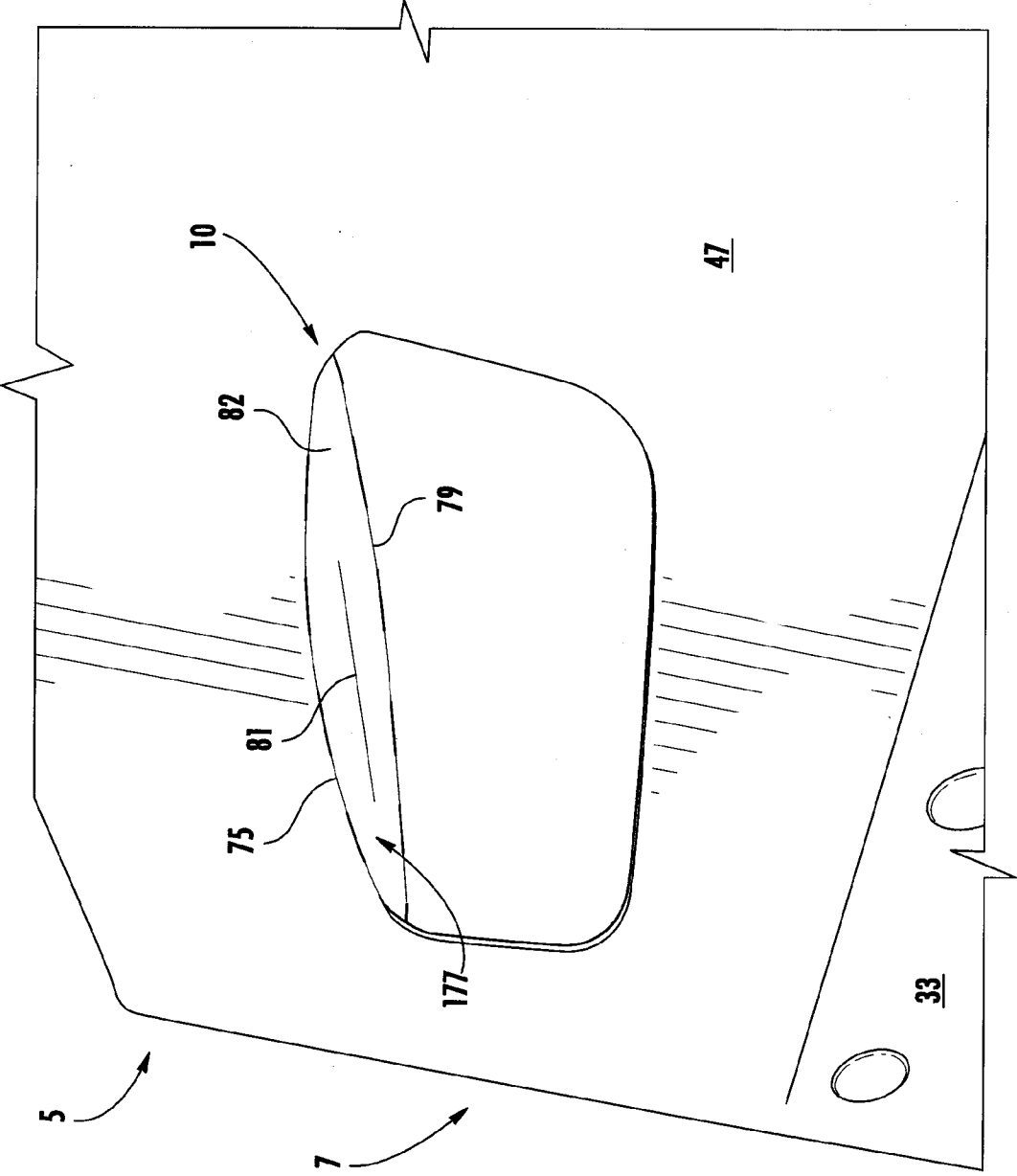
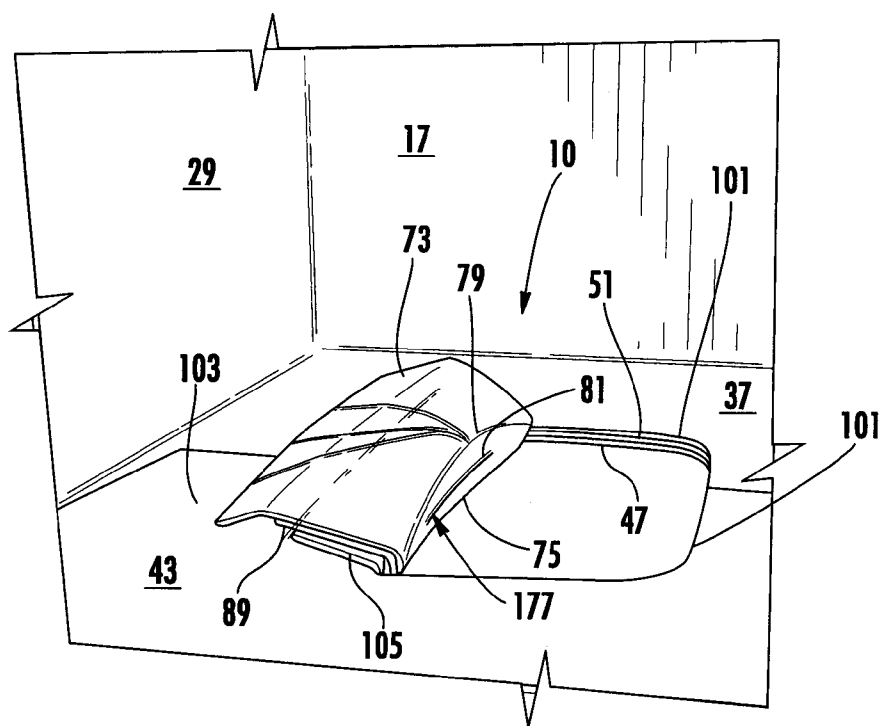

FIG. 6



**FIG. 7**

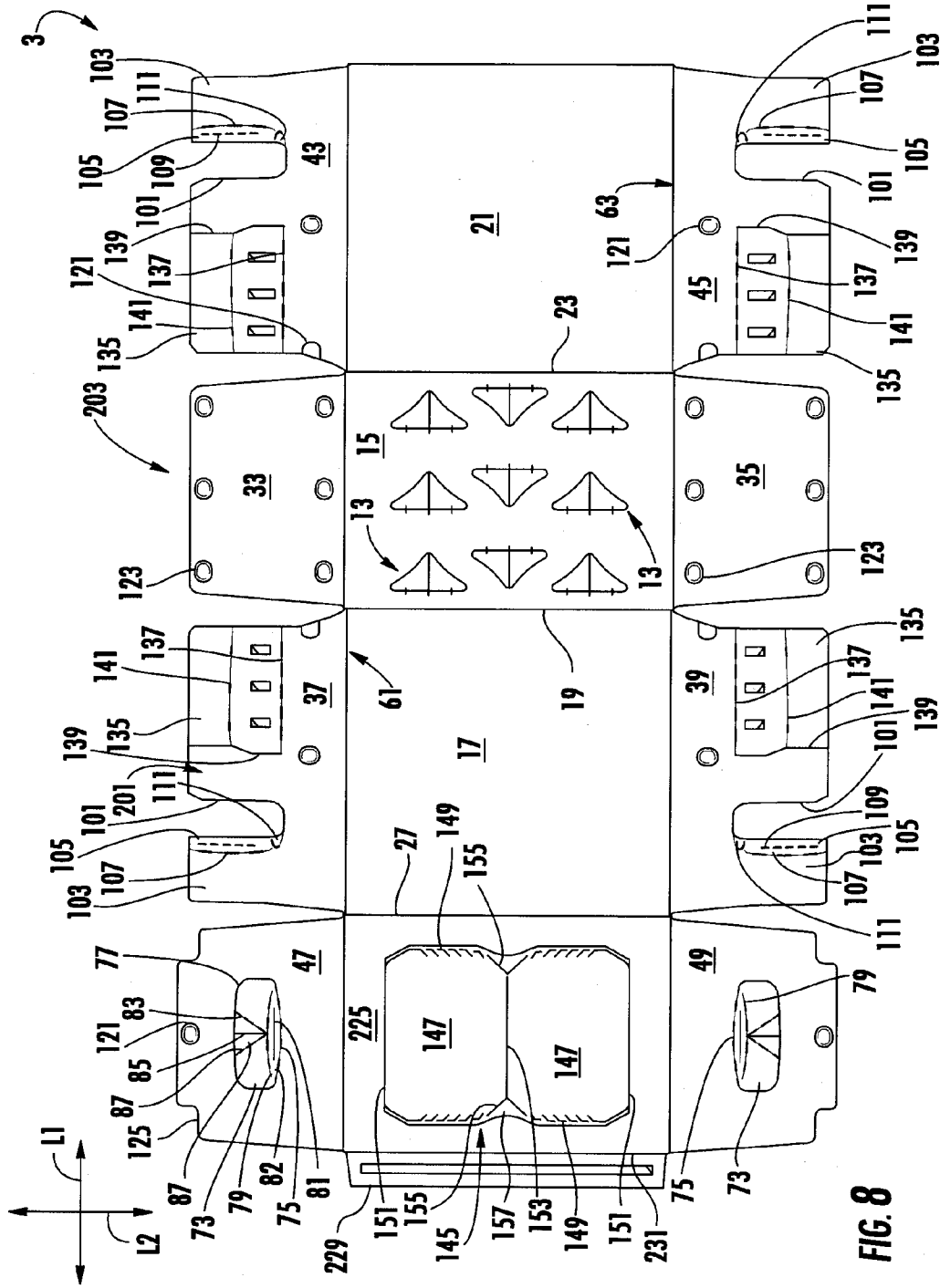
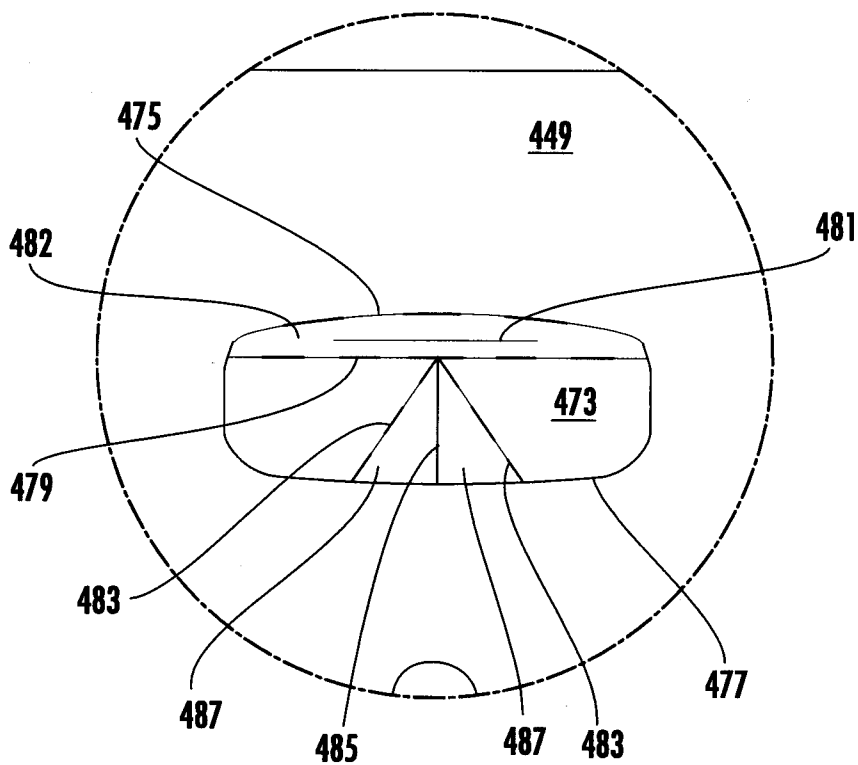

FIG. 8





**FIG. 9A**

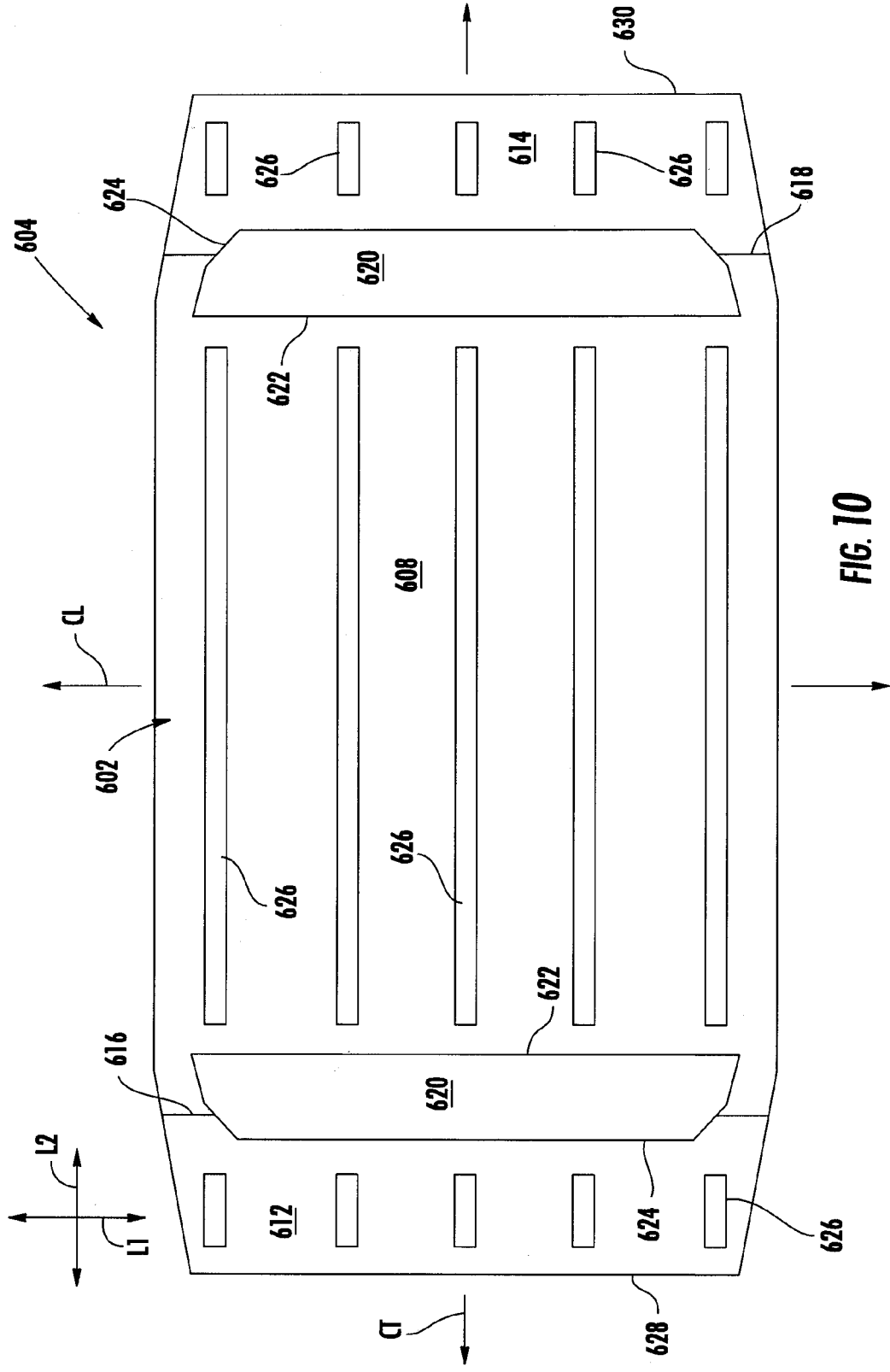
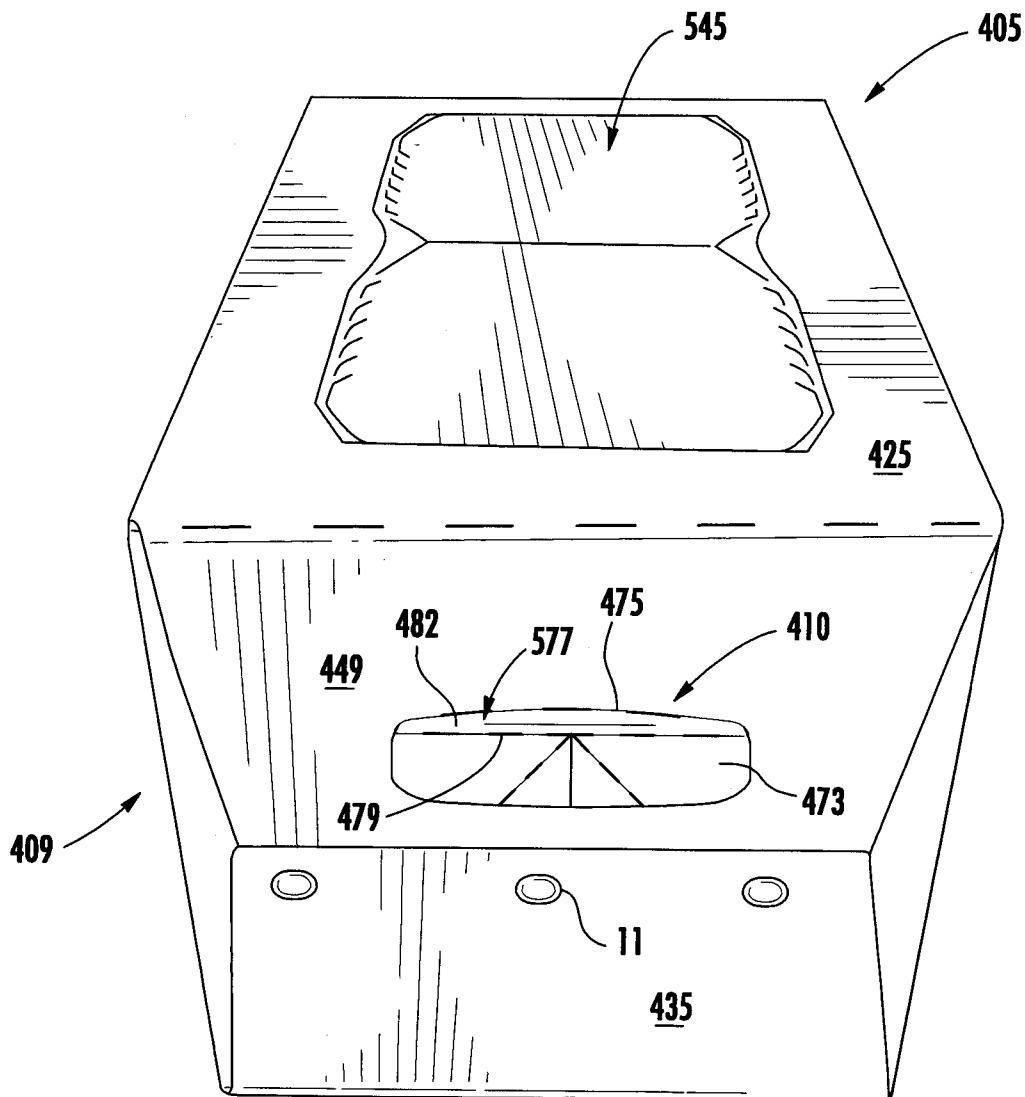

FIG. 10





**FIG. 12**

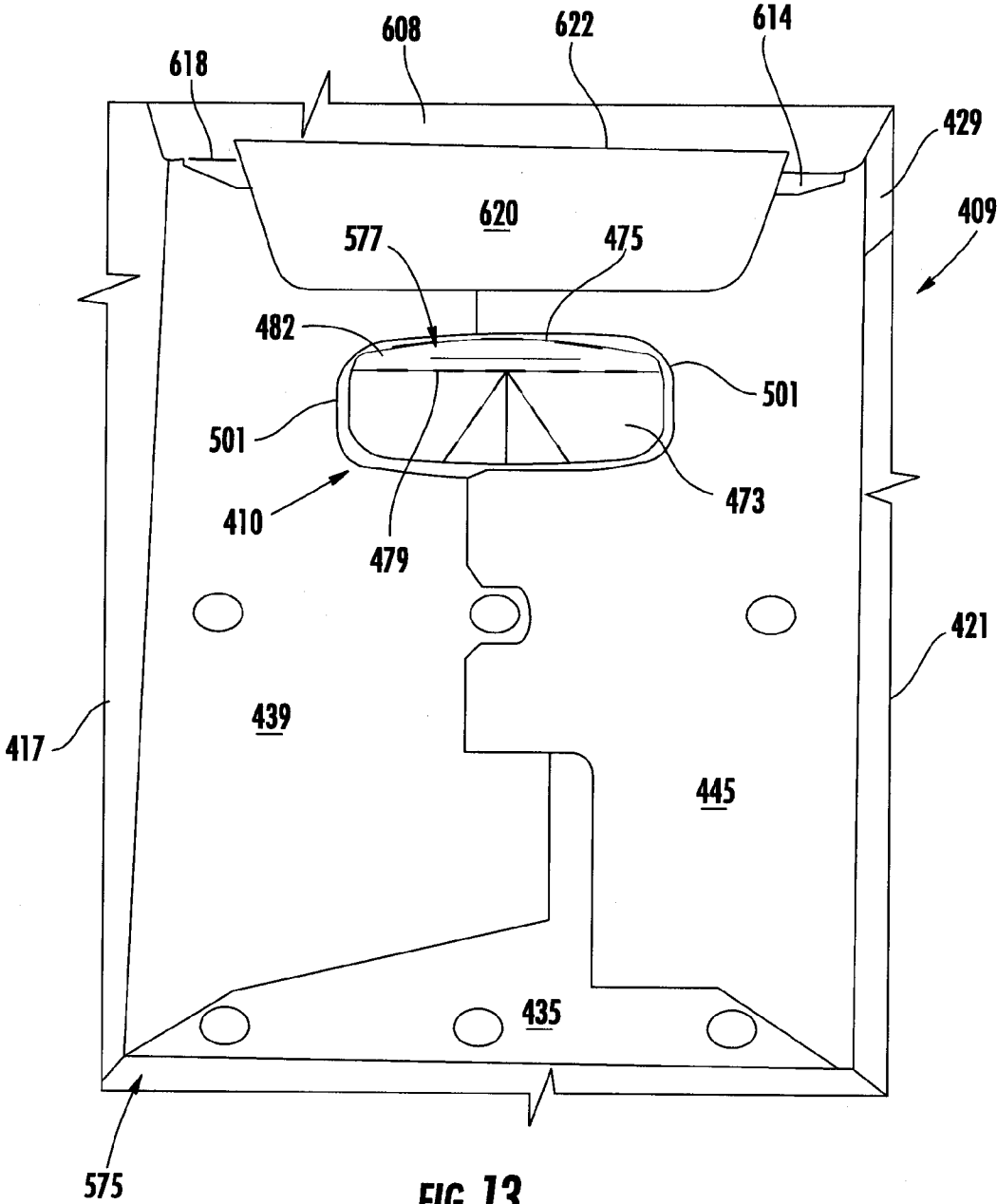

FIG. 13

**CARTON WITH HANDLE**

**CROSS-REFERENCE TO RELATED APPLICATIONS**

[0001] This application claims the benefit of U.S. Provisional Patent Application No. 61/797,758, filed Dec. 14, 2012, U.S. Provisional Patent Application No. 61/741,314, filed Jul. 17, 2012, and U.S. Provisional Patent Application No. 61/741,315, filed Jul. 17, 2012.

**INCORPORATION BY REFERENCE**

[0002] The disclosures of U.S. Provisional Patent Application No. 61/797,758, which was filed on Dec. 14, 2012, U.S. Provisional Patent Application No. 61/741,314, which was filed on Jul. 17, 2012, and U.S. Provisional Patent Application No. 61/741,315, which was filed on Jul. 17, 2012, are hereby incorporated by reference for all purposes as if presented herein in their entirety.

**BACKGROUND OF THE DISCLOSURE**

[0003] The present disclosure generally relates to cartons for holding beverage containers or other types of articles. More specifically, the present disclosure relates to cartons having handle features.

**SUMMARY OF THE DISCLOSURE**

[0004] In general, one aspect of the disclosure is directed to a carton for holding a plurality of containers. The carton can comprise a plurality of panels that extends at least partially around an interior of the carton. At least one end flap can be foldably connected to at least one panel of the plurality of panels. The at least one end flap can at least partially form a closed end of the carton. At least one handle comprises at least one handle flap foldably connected to the at least one end flap along a first fold line. The at least one handle flap comprises a grip portion at least partially defined by the first fold line and a second fold line extending in the at least one handle flap. The first fold line and the second fold line are nonparallel.

[0005] In another aspect, the disclosure is generally directed to a blank for forming a carton for holding a plurality of containers. The blank can comprise a plurality of panels and at least one end flap foldably connected to at least one panel of the plurality of panels. The at least one end flap is for at least partially forming a closed end of the carton formed from the blank. The blank can also comprise handle features for forming at least one handle comprising at least one handle flap foldably connected to the at least one end flap along a first fold line. The at least one handle flap comprises a grip portion at least partially defined by the first fold line and a second fold line extending in the at least one handle flap. The first fold line and the second fold line are nonparallel.

[0006] In another aspect, the disclosure is generally directed to a method of forming a carton for holding a plurality of containers. The method can comprise obtaining a carton comprising a plurality of panels that extends at least partially around an interior of the carton. At least one end flap is foldably connected to at least one panel of the plurality of panels. The at least one end flap can at least partially form a closed end of the carton. At least one handle comprises at least one handle flap foldably connected to the at least one end flap along a first fold line. The at least one handle flap comprises a grip portion at least partially defined by the first fold line and a second fold line extending in the at least one handle flap.

The first fold line and the second fold line are nonparallel. The method can further comprise actuating the at least one handle by folding the at least one handle flap along the first fold line and the second fold line.

[0007] Those skilled in the art will appreciate the above stated advantages and other advantages and benefits of various additional embodiments reading the following detailed description of the embodiments with reference to the below-listed drawing figures. It is within the scope of the present disclosure that the above-discussed aspects be provided both individually and in various combinations.

**BRIEF DESCRIPTION OF THE DRAWINGS**

[0008] According to common practice, the various features of the drawings discussed below are not necessarily drawn to scale. Dimensions of various features and elements in the drawings may be expanded or reduced to more clearly illustrate the embodiments of the disclosure.

[0009] FIG. 1 is an exterior plan view of a blank used to form a carton according to a first exemplary embodiment of the disclosure.

[0010] FIG. 1A is a detail view of handle features of the blank of FIG. 1.

[0011] FIG. 2 is an interior view of a portion of the blank of FIG. 1 with inwardly folded corner flaps.

[0012] FIG. 3 is a perspective view of a partially-erected carton in the form of an open-ended sleeve according to the first exemplary embodiment of the disclosure.

[0013] FIG. 3A is a perspective view of the open-ended sleeve of FIG. 3 with containers loaded therein.

[0014] FIG. 4 is a perspective view showing the assembled carton according to the first exemplary embodiment of the disclosure.

[0015] FIG. 5 is an interior perspective view of a handle in an end of the carton of FIG. 4.

[0016] FIG. 6 is an exterior perspective view of the handle of FIG. 5 after activation of the handle according to the first exemplary embodiment of the disclosure.

[0017] FIG. 7 is an interior perspective view of the activated handle of FIG. 6.

[0018] FIG. 8 is an exterior plan view of a blank used to form a carton according to a second exemplary embodiment of the disclosure.

[0019] FIG. 9 is an exterior plan view of a blank used to form a carton according to a third exemplary embodiment of the disclosure.

[0020] FIG. 9A is a detail view of handle features of the blank of FIG. 9.

[0021] FIG. 10 is an exterior plan view of a reinforcing insert for reinforcing the carton according to the third exemplary embodiment of the disclosure.

[0022] FIG. 11 is a perspective view of a partially-erected carton in the form of an open-ended sleeve according to the third exemplary embodiment of the disclosure.

[0023] FIG. 12 is a perspective view of the assembled carton according to the third exemplary embodiment of the disclosure.

[0024] FIG. 13 is an interior perspective view of a handle in an end of the carton of FIG. 12.

[0025] Corresponding parts are designated by corresponding reference numbers throughout the drawings.

DETAILED DESCRIPTION OF THE  
EXEMPLARY EMBODIMENTS

**[0026]** The present disclosure generally relates to cartons that contain articles such as containers, bottles, cans, etc. The articles can be used for packaging food and beverage products, for example. The articles can be made from materials suitable in composition for packaging the particular food or beverage item, and the materials include, but are not limited to, aluminum and/or other metals; glass; plastics such as PET, LDPE, LLDPE, HDPE, PP, PS, PVC, EVOH, and Nylon; and the like, or any combination thereof.

**[0027]** Cartons according to the present disclosure can accommodate articles of any shape. For the purpose of illustration and not for the purpose of limiting the scope of the disclosure, the following detailed description describes beverage containers (e.g., glass beverage bottles) as disposed within the carton embodiments. In this specification, the terms “inner,” “outer,” “lower,” “bottom,” “upper,” and “top” indicate orientations determined in relation to fully erected and upright cartons.

**[0028]** FIG. 1 is a plan view of the exterior side 1 of a blank, generally indicated at 3, used to form a carton 5 (FIG. 4) according to a first exemplary embodiment of the disclosure. The carton 5 can be used to house a plurality of articles such as containers C (FIG. 3A). In one embodiment, the containers are bottles having a wide bottom and a narrow top or neck T including a cap CP. In the illustrated embodiment, the carton 5 is sized to house twelve containers C in a single layer in a 3×4 arrangement, but it is understood that the carton 5 may be sized and shaped to hold containers of a different or same quantity in more than one layer and/or in different row/column arrangements (e.g., 1×6, 2×6, 4×6, 3×8, 2×6×2, 3×4×2, 2×9, 3×6, etc.), or just a single article. In the illustrated embodiment, the carton 5 includes a first end 7 and a second end 9, each with a respective handle, generally indicated at 10 (FIGS. 4-7) for grasping and carrying the carton at each of the ends 7, 9. The carton 5 could have only a single handle 10 in either of the ends 7, 9 without departing from the disclosure. As will be discussed below in more detail, the handles 10 are formed from various features in the carton blank 3.

**[0029]** In one embodiment, the first end 7 and the second end 9 of the carton 5 each have article protection features 11 (FIG. 4) for protecting at least one article C of the plurality of articles. Additionally, the carton 5 of the first embodiment may have article protection flaps 13 for protecting the at least one article. The article protection features 11 cushion the ends 7, 9 of the carton and prevent or reduce the likelihood of breakage of the containers C. In one embodiment, the article protection flaps 13 are movable between a first position (FIG. 1) and a second position (not shown) placed between adjacent containers C in the carton to reduce movement of the containers in the carton and prevent breakage of the containers. The article protection features and flaps can be similar to, or the same as, those described in U.S. patent application Ser. No. 13/419,740, filed Mar. 14, 2012, the disclosure of which is hereby incorporated by reference for all purposes as if presented herein in its entirety. The article protection features 11 and/or the article protection flaps 13 can be otherwise shaped, arranged, and/or configured without departing from the disclosure. Further, the article protection features 11 and/or article protection flaps 13 can be omitted without departing from the disclosure.

**[0030]** The carton blank 3 has a longitudinal axis L1 and a lateral axis L2. In the embodiment of FIG. 1, the blank

includes a bottom panel 15 foldably connected to a first side panel 17 at a lateral fold line 19. A second side panel 21 is foldably connected to the bottom panel 15 at a lateral fold line 23. An outer or first top panel 25 is foldably connected to the first side panel 17 at a lateral fold line 27, and an inner or second top panel 29 is foldably connected to the second side panel 21 at a lateral fold line 31. Any of the top and bottom panels 25, 29, 15 and the first and second side panels 17, 21 can be otherwise shaped, arranged, configured, or omitted, without departing from the disclosure. For example, the second top panel 29 could be a separate insert formed from a separate insert blank, or the second top panel could be omitted and an attachment flap can be foldably connected to the first top panel 25 or the second side panel 21.

**[0031]** The bottom panel 15 is foldably connected to a first bottom end flap 33 and a second bottom end flap 35. The first side panel 17 is foldably connected to a first side end flap 37 and a second side end flap 39. The second side panel 21 is foldably connected to a first side end flap 43 and a second side end flap 45. The first top panel 25 is foldably connected to a first (e.g., outer) top end flap 47 and a second (e.g., outer) top end flap 49. The second top panel 29 is foldably connected to a first (e.g., inner) top end flap 51 and a second (e.g., inner) top end flap 53. In one embodiment, when the carton 5 is erected, the end flaps 33, 37, 43, 47, 51 close the first end 7 of the carton, and the end flaps 35, 39, 45, 49, 53 close the second end 9 of the carton. In accordance with an alternative embodiment of the present disclosure, different flap arrangements can be used for closing the ends 7, 9 of the carton 5.

**[0032]** The end flaps 33, 37, 43, 47, 51 extend along a first marginal area of the blank 3, and are foldably connected at a first longitudinal fold line 61 that extends along the length of the blank. The end flaps 35, 39, 45, 49, 53 extend along a second marginal area of the carton blank 3, and are foldably connected at a second longitudinal fold line 63 that also extends along the length of the blank. The longitudinal fold lines 61, 63 may be, for example, substantially straight, or offset at one or more locations to account for blank thickness or for other factors. The ends of the carton 5 could be otherwise shaped, arranged, and/or configured (e.g., at least partially tapered) without departing from the disclosure.

**[0033]** As shown in FIG. 1, a first fold line or area 65 and a second fold line or area 67 connect the respective top end flaps 51, 53 to the second top panel 29 along the marginal areas of the blank 3. In the illustrated embodiment, each of the fold areas 65, 67 can include several fold lines (e.g., scores, creases, cut-crease lines, etc.). Alternatively, the fold areas 65, 67 can be other lines or areas of weakening (e.g., a single fold line) for folding the top end flaps 51, 53 relative to the second top panel 29. Openings 69 can interrupt the fold areas 65, 67 to help avoid bunching of the blank material at the ends 7, 9 of the erected carton 5 that might otherwise occur since the second top panel 29 and the top end flaps 51, 53 are interior to the first top panel 25 and the top end flaps 47, 49 in the erected carton.

**[0034]** In the embodiment of FIG. 1, the carton blank 3 has handle features for forming the handles 10. As shown in FIGS. 1 and 1A, the handle features comprise outer handle flaps 73 foldably connected to a respective top end flap 47, 49 at an arcuate fold line 75 and separable from the respective top end flap 47, 49 along cut lines 77. An opposing arcuate fold line 79 extends in each of the outer handle flaps 73 and generally mirrors the arcuate fold line 75. In one embodiment, the arcuate fold line 75 can have a radius of curvature

extending in a first direction (e.g., generally toward the top panel 25), and the opposing arcuate fold line 79 can have a radius of curvature extending in a second, opposing direction (e.g., generally away from the top panel 25). Stated another way, the arcuate fold line 75 can be convex with respect to the top panel 25, and the opposing arcuate fold line 79 can be concave with respect to the top panel 25. Accordingly, the fold lines 75, 79 are opposing arcs and generally comprise nonparallel fold lines. In one embodiment, nonparallel fold lines can refer to a first fold line that is curved in one direction and a second fold line that is either straight or that is curved in an opposing direction. In the illustrated embodiment, the arcuate fold lines 75, 79 are cut-crease lines; however, the fold lines could be otherwise configured (e.g., scores, creases, perforations, etc.). A grip portion 82 generally can be defined between the arcuate fold line 75 and the opposing arcuate fold line 79 in each of the outer handle flaps 73. In one embodiment, the grip portions 82 can be for contacting a hand of a user when grasping the handles 10. Accordingly, as the outer handle panels 73 are folded inwardly, the outer handle panels fold along both of the arcuate fold lines 75, 79 so that the grip portions 82 form a wider contact area for a user's hands, thereby helping to make the material at the handle 10 feel thicker and more comfortable for the user. In one embodiment, each outer handle flap 73 includes a longitudinal score 81 extending in the grip portion 82.

[0035] In the illustrated embodiment, each of the outer handle flaps 73 can include oblique fold lines 83 and a lateral cut 85, which can form generally triangular flaps 87 that can help accommodate the narrow top or neck T of a container C adjacent the respective handle 10. Accordingly, when the respective outer handle flap 73 is folded inwardly in the carton 5, the triangular flaps 87 can separate along the respective cuts 85 and fold outwardly along the oblique fold lines 83 upon contact with the narrow top T of the respective container C. The outer handle flaps 73 could be otherwise shaped, arranged, and/or configured without departing from the disclosure.

[0036] As shown in FIG. 1, the handle features further can include an inner handle flap 89 defined in each of the top end flaps 51, 53. Each of the inner handle flaps 89 is foldably connected to the respective top end flap 51, 53 along an arcuate fold line 91 and is separable from the respective top end flap along cut lines 93. In one embodiment, the inner handle flaps 89 extend adjacent respective openings 95 in the top end flaps. An opposing arcuate fold line 97 extends in each of the handle flaps 89 and generally mirrors the arcuate fold lines 91. In the illustrated embodiment, the arcuate fold lines 91, 97 can be generally similar to the arcuate fold lines 75, 79 and can be positioned and configured so that the arcuate fold lines 75, 79 generally overlap the arcuate fold lines 91, 97 in the erected carrier 5. Accordingly, the fold lines 91, 97 are opposing arcs and generally comprise nonparallel fold lines. In one embodiment, the arcuate fold line 91 can have a radius of curvature extending in a first direction (e.g., generally toward the top panel 29), and the opposing arcuate fold line 97 can have a radius of curvature extending in a second, opposing direction (e.g., generally away from the top panel 29). Stated another way, the arcuate fold line 91 can be convex with respect to the top panel 29, and the opposing arcuate fold line 97 can be concave with respect to the top panel 29. In an alternative embodiment, one of the arcuate fold lines 91, 97 could be replaced with a generally straight fold line. In one embodiment, each handle flap 89 includes a longitudinal

cut-crease line 99 extending between the arcuate fold line 91 and the opposing arcuate fold line 97. A folding portion 100 can be generally defined between the arcuate fold line 91 and the opposing arcuate fold line 97 in each of the inner handle flaps 89. When the handles 10 are formed, the grip portions 82 of the outer handle flaps 73 generally can overlap the respective folding portions 100, and the folding portions 100 can cooperate with the respective grip portions 82 to help form the wider contact areas of the handles. The inner handle flaps 89 could be omitted or could be otherwise shaped, arranged, and/or configured without departing from the disclosure.

[0037] The handle features can also include notches or openings 101 in the side end flaps 37, 39, 43, and 45. The openings 101 cooperate to provide an opening at a respective closed end 7, 9 to allow a respective handle flap 73 and inner handle flap 89 to be inwardly folded at a respective end. The side end flaps 37, 39, 43, 45 can also include respective upper portions 103 disposed above the respective openings 101. As shown in FIGS. 1 and 1A, a side handle flap 105 can be foldably connected to the upper portion 103 of each side end flap 37, 39, 43, 45 along a respective arcuate fold line 107 and can extend adjacent the respective openings 101. In one embodiment, the arcuate fold lines 75, 91 can generally overlap the arcuate fold lines 107 at each end of the carton when the ends 7, 9 are closed. Each of the side handle flaps 105 can include a lateral perforated line 109 and a corner comfort radius 111. As shown in FIG. 1A, the corner comfort radius 111 can be defined by a score 113 and a cut 115 extending from the score 113 and curving toward the edge of the side handle flap 105. Accordingly, the corner comfort radius 111 can separate from the remainder of the side handle flap 105 along the cut 115 and fold along the score 113 to help protect a user's hands from rough edges in the corner of the handle opening formed when the handle 10 is activated. The blank 3 can have other features for forming the handles 10, or the blank 3 and/or carton 5 can have one or more handles that are alternatively shaped, arranged, and/or configured without departing from the disclosure. For example, any or all of the outer handle flaps 73, the inner handle flaps 89, or the side handle flaps 105 could be omitted. Further, one or both of the handles 10 can be omitted without departing from the disclosure.

[0038] In one embodiment, the carton blank 3 has features for forming the article protection features 11 of the carton 5. As shown in FIG. 1, the side end flaps 37, 39, 43, 45 and the top end flaps 47, 49 have deformations in the form of indentations 121 on the exterior surface of the carton blank 3 such that the indentations form a protrusion on the interior surface of the blank. The bottom end flaps 33, 35 each have two rows of deformations in the form of indentations 123 on the interior surface of the carton blank 3 such that the indentations on the interior surface form a protrusion on the exterior surface 1 of the carton blank 3. As shown in FIG. 1, the top end flaps 47, 49 each have corner notches 125. The indentations 121, 123 can be any deformation on a surface of a respective side end flaps 37, 39, 43, 45, top end flaps 47, 49, or bottom end flaps 33, 35 such that the deformation can be any suitable shape (e.g., a concave depression or protrusion, convex depression or protrusion, flat depression or protrusion, embossed area, debossed area, etc., or any other suitable shape). Furthermore, the indentations 121, 123 could be formed on the interior or exterior surface of one or more of the first side panel 17, second side panel 21, top panel 25, bottom panel 15, and/or top end flaps 51, 53 without departing from the disclosure.

[0039] In the first embodiment, the carton blank 3 includes nine article protection flaps 13 arranged in a 3×3 arrangement, but the blank could have more or less than nine article protection flaps, and the flaps could be otherwise arranged in other suitable row/column arrangements or in a random configuration on the bottom panel 15, including a single row or single column configuration, or any other suitable configuration. In other embodiments, the carton blank 3 can include article protection flaps that are different, similar, or identical to other article protection flaps without departing from the disclosure. In the embodiment of FIG. 1, the middle row of article protection flaps 13 are oriented 180 degrees relative to a row of article protection flaps that are closer to the respective longitudinal fold lines 61, 63. In other embodiments, the article protection flaps 13 could be otherwise shaped, arranged, and/or configured without departing from the disclosure.

[0040] As shown in FIG. 1, the article protection flaps 13 are each foldably connected to the bottom panel 15 at a respective lateral fold line 127 and are each at least partially defined by a cut 129 in the bottom panel. Alternatively, the cut 129 could comprise other forms of weakening (e.g., a tear line that comprises cut lines separated by breakable nicks, a tear line that is formed by a series of spaced apart cuts, etc.) that allow the article protection flap 13 to be separated from the bottom panel 15 without departing from the disclosure. In one embodiment, a slit or cut 131 extends laterally from a portion of the cut 129 that is opposite to the lateral fold line 127. As shown in FIG. 1, the article protection flap 13 can comprise generally longitudinal fold lines 133 extending from the lateral fold line 127. The fold lines 127, 133 and cuts 129, 131 could be otherwise shaped, arranged, configured, and/or omitted such that the article protection flap 13 has any other suitable shape or configuration without departing from the disclosure.

[0041] In the illustrated embodiment, a corner flap 135 can be foldably connected to each of the side end flaps 37, 39, 43, 45. The corner flaps 135 can help secure the containers C in the carton 5 and/or help reinforce the corners of the carton. Each of the corner flaps 135 can be foldably connected to the respective side end flap along a longitudinal fold line 137 and separable from the respective side end flap along a cut line 139. Each of the corner flaps 135 can include an intermediate fold line 141 extending from the cut line 139 to a lateral free edge of the respective side end flap. Accordingly, the corner flaps 135 can be folded adjacent the respective corners of the carton 5 (FIG. 5) to at least partially conform to the shape of the containers C adjacent the corners and reduce the freedom of movement of the corner containers. The corner flaps 135 could be otherwise shaped, arranged, and/or configured without departing from the disclosure.

[0042] As shown in FIG. 1, the blank 3 includes dispenser features for forming a dispenser 143 in the carton 5 (FIG. 4). As shown in FIG. 1, the dispenser features include an outer dispenser 145 formed in the first top panel 25. The outer dispenser 145 includes two outer dispenser panels 147 that are separable from the remainder of the first top panel 25 along tear lines 149 and are foldably connected to the first top panel 25 along a respective longitudinal fold line 151. The outer dispenser panels 147 are separable from one another along a longitudinal tear or cut line 153. V-shaped cuts 155 at each end of the cut line 153 define outer projections 157 in the first top panel 25. The tear lines 149, fold lines 151, cut line

153, and V-shaped cuts 155 could be otherwise shaped, arranged, and/or configured without departing from the disclosure.

[0043] In the illustrated embodiment, the dispenser features further can include an inner dispenser 159 in the second top panel 29. The inner dispenser 159 includes inner dispenser panels 161 that are separable from the remainder of the second top panel 29 along cut lines 163 and are foldably connected to the second top panel 29 along respective longitudinal fold lines 165. The inner dispenser panels 161 can be separable from one another along tear lines 167 and can define a finger aperture 169 therebetween. The cut lines 163 can be shaped and disposed in the second top panel 29 so that, when the carton 5 is formed and the first top panel 25 overlaps the second top panel 29, the outer projections 157 overlap portions of the cut lines 163 and corner portions 171 of the inner dispenser panels 161. Accordingly, the corner portions 171 can interfere with the outer projections 157 to help retain the dispenser 143 in a reclosed position after initial opening of the dispenser. When opening the dispenser 143, the corner portions 171 can fold out of the way of the outer projections 157. The cut lines 163, fold lines 165, and tear lines 167 could be otherwise shaped, arranged, and/or configured without departing from the disclosure. Additionally, the outer dispenser 145 and the inner dispenser 159 could be otherwise shaped, arranged, and/or configured without departing from the disclosure.

[0044] As shown in FIG. 2, the blank 3 can be prepared for forming the carton 5 by folding each of the corner flaps 135 in the respective side end flaps 37, 39, 43, 45 along the respective longitudinal fold lines 137 so that the corner flaps 135 overlap the respective side end flap and the respectively adjacent side panel 17, 21. In one embodiment, at least the portion of each corner flap 135 between the longitudinal fold line 137 and the intermediate fold line 141 can be glued to the respective side end flap 37, 39, 43, 45. Alternatively, or in addition, the corner flaps 135 can be glued to the respective side panels 17, 21, or the glue could be omitted from the corner flaps so that they are free to pivot and/or slide relative to the side end flaps and/or the side panels.

[0045] In one exemplary embodiment, the carton 5 can be assembled further by folding the blank 3 along the transverse fold line 31 so that the second top panel 29 overlaps the interior surface of the second side panel 21 and folding the blank along the transverse fold line 19 so that the first top panel 25 overlaps the second top panel 29. Alternatively, the blank could be folded along the transverse fold lines 23, 27 so that the first top panel 25 overlaps the second top panel 29. The first top panel 25 can be glued to the second top panel 29, and the outer dispenser panels 147 can be glued to the inner dispenser panels 161. In one embodiment, the corner portions 171 of the inner dispenser panels 161 are not glued to the outer projections 157 of the first top panel 25. The top end flaps 47, 49 at least partially overlap the respective top end flaps 51, 53, and the top end flaps 47, 49 can be glued to the top end flaps 51, 53. In one embodiment, the outer handle flaps 73 in the top end flaps 47, 49 are glued to the respective inner handle flaps 89 in the top end flaps 51, 53. As shown in FIGS. 3 and 3A, the blank then can be folded along fold lines 19, 23, 27, 31 to form an open-ended sleeve 173 with an interior 175. As shown in FIG. 3A, the containers C can be loaded into the interior 175 of the open-ended sleeve 173 before or after closing either of the ends 7, 9. The blank 3 may be otherwise

formed into the open-ended sleeve using alternative folding and gluing steps without departing from the scope of this disclosure.

[0046] In the illustrated embodiment, the side end flaps 37, 43 are inwardly folded along the longitudinal fold line 61 to at least partially close the first end 7. As the side end flaps 37, 43 are folded, the corner flaps 135 slide against the respective side panels 17, 21 and bend along the respective intermediate fold lines 141 to bend around the corners of the carton 5. Additionally, when the containers are loaded into the interior 175 of the sleeve 173, the corner flaps 135 can bend to generally conform to the curve of the respectively adjacent containers. The top end flaps 47, 51 are folded along the longitudinal fold line 61 and the fold area 65, respectively, so that the top end flaps 47, 51 overlap the side end flaps 37, 43 and the handle flaps 73, 89 are generally aligned with the openings 101. In one embodiment, the inner top end flap 51 is glued in face-to-face contact with the side end flaps 37, 43. The bottom end flap 33 is folded upwardly along the longitudinal fold line 61 into face-to-face contact with the lower portions of the side end flaps 37, 43. In one embodiment, the bottom end flap 33 overlaps a portion of the outer top end flap 47 (FIG. 4). The bottom end flap 33 can be glued to the side end flaps 37, 43 and/or the top end flap 47. Accordingly, the handle 10 (FIGS. 4 and 5) in the first end 7 is formed by the alignment of the handle flap 73 of the outer top end flap 47, the handle flap 89 and the opening 95 of the inner top end flap 51, and the openings 101 and the side handle flaps 105 of the side end flaps 37, 43. The top end flaps 47, 51, the side end flaps 37, 43, and the bottom end flap 33 can be selectively adhered to one another to close the first end 7 of the carton 5 (FIG. 4).

[0047] In one embodiment, the second end 9 of the carton 5 can be closed in a similar manner as the first end 7 by folding, respectively overlapping, and selectively adhering the side end flaps 39, 45, the top end flaps 49, 53, and the bottom end flap 35. The erected carton is shown in FIG. 4. One or both of the ends 7, 9 could be otherwise shaped, arranged, configured, or omitted, without departing from the disclosure. Additionally, the open-ended sleeve 173 can be alternatively loaded with containers and closed without departing from the disclosure. For example, the ends 7, 9 can be closed in any order, and the containers could be loaded before or after closing either or both of the ends 7, 9. Additionally, the corner flaps 135 could be folded along longitudinal fold lines 137 and/or glued before or after any step of forming the carton 5.

[0048] As shown in FIG. 5, which shows the first end 7 of the carton 5 from the interior 175 of the carton, the side handle flaps 105 of the side end flaps 43, 37, the inner handle flap 89 of the top end flap 51, and the outer handle flap 73 of the top end flap 47 are overlapped to form the handle 10 in the first end 7. As shown in FIGS. 6 and 7, the handles 10 can be used to grasp the carton 5 by pressing against the outer handle flaps 73 to force the outer handle flaps 73 and the inner handle flaps 89 inwardly through the handle openings 95 of the top end flaps 51, 53 and the handle openings 101 of the side end flaps 37, 39, 43, 45 to provide a handle opening in the closed ends 7, 9 of the carton 5. For each of the handles 10, as the outer handle panel 73 and the inner handle panel 89 fold inwardly, the outer handle panel 73 and the inner handle panel can fold inwardly along the respective arcuate fold lines 75, 91 (FIGS. 6 and 7). As shown in FIG. 7, the handle panels 73, 89 can be folded upwardly toward the interior surface of the upper portions 103 of the side end flaps along the respective opposing arcuate fold lines 79, 97 as the user grasps the handle 10.

Accordingly, the grip portions 82 of the outer handle flaps 73 and the folding portions 100 of the inner handle flaps 89 extend at an angle with respect to the top end flaps 47, 51 or 49, 53 and the remainders of the handle flaps 73, 89 to form hand contact areas 177 (FIGS. 6 and 7). In one embodiment, the hand contact areas 177 can extend generally horizontally into the interior 175 of the carton 5. The hand contact areas 177 of the handles 10 can help make the material of the carton 5 at the handles 10 feel like it is thicker than it is. Additionally, the hand contact areas 177 can provide a wider area that is supported by the user's hands, which is more comfortable than supporting the carton 5 along a single fold line. The opposing arcuate fold lines 75, 79 and 91, 97 help avoid a situation where the weight of the carton 5 and the containers disposed therein is supported by a user's hands at a single fold line in each handle, which could more easily occur if each of the handle panels fold along a single fold line or along parallel fold lines.

[0049] In the illustrated embodiment, the inwardly folding handle flaps 73, 89 can contact the overlapped side handle flaps 105 in the side end flaps 37, 43 or 39, 45 and fold the handle flaps 105 inwardly along fold lines 107. Accordingly, the side handle flaps 105 can provide additional material above the handles 10. The handles 10 could be alternatively, shaped, arranged, configured, and/or reinforced without departing from this disclosure.

[0050] FIG. 8 is a plan view of an exterior surface 201 of an alternative blank 203 for forming a carton (not shown) according to a second embodiment of the disclosure. The second embodiment is generally similar to the first embodiment, except for variations noted and variations that will be apparent to one of ordinary skill in the art. Accordingly, similar or identical features of the embodiments have been given like or similar reference numbers. As shown in FIG. 8, the blank 203 does not include an inner top panel foldably connected to the second side panel or inner top end flaps. The blank 203 includes an attachment flap 229 foldably connected to the top panel 225 along a transverse fold line 231. Alternatively, the attachment flap 229 could be foldably connected to the second side panel 21. In one embodiment, a reinforcing insert (not shown) can be attached to the top panel 225 and/or the top end flaps 47, 49. For example, a reinforcing insert could be generally similar to the inner top panel and/or the inner top end flaps 51, 53 of the first embodiment. Alternatively, a different insert could be used with the blank 203, or the blank 203 is not used with an insert. The blank 203 can be formed into an open-ended sleeve (not shown) by folding along the transverse fold lines 19, 23, 27, 231 and gluing the attachment flap 229 to the interior surface of the second side panel 21. The carton can be erected generally similar to the formation of the carton 5 of the first embodiment described above. The blank 203 could be otherwise shaped, arranged, and/or configured without departing from the disclosure.

[0051] FIG. 9 is a plan view of an exterior surface 401 of an alternative carton blank 403 for forming a carton 405 (FIG. 12) according to a third embodiment of the disclosure. The third embodiment is generally similar to the second embodiment, except for variations noted and variations that will be apparent to one of ordinary skill in the art. Accordingly, similar or identical features of the embodiments have been given like or similar reference numbers. The blank 403 can be used with a reinforcing insert 604 (FIG. 10) or an alternative insert for forming a reinforced carton. The carton blank 403

and/or the reinforcing insert 604 could be otherwise shaped, arranged, and/or configured without departing from the disclosure.

[0052] As shown in FIG. 9, the carton blank 403 can include a row of three article protection flaps 13 foldably connected to the bottom panel 417. The article protection flaps 13 could be otherwise shaped, arranged, and/or configured without departing from the disclosure. For example, the carton blank 403 could include any suitable number of article protection flaps 13, or the article protection flaps 13 could be omitted. An outer dispenser 545 includes outer dispenser panels 547 foldably connected to the top panel 425 along longitudinal fold lines 551 and separable from the top panel 425 along tear lines 549. The outer dispenser 545 could be otherwise shaped, arranged, and/or configured without departing from the disclosure. For example, the outer dispenser could be at least partially disposed in the first side panel 417 or the second side panel 421. In an alternative embodiment, the outer dispenser 545 could be omitted.

[0053] As shown in FIG. 9, the side end flaps 437, 439, 443, 445 include handle notches or openings 501 and upper portions 503 disposed above the openings 501. In the illustrated embodiment, the side end flaps 437, 439, 443, 445 do not include side handle flaps (e.g., the side handle flaps 105 of the first embodiment) foldably connected to the upper portions 503. Additionally, as shown in FIG. 9, the side end flaps 437, 439, 443, 445 do not include corner flaps (e.g., the corner flaps 135 of the first embodiment). In an alternative embodiment, side handle flaps (e.g., the side handle flaps 105 shown and described in the first embodiment) and/or corner flaps (e.g., the corner flaps 135 shown and described in the first embodiment) could be incorporated into any of the side end flaps 437, 439, 443, 445. The side end flaps 437, 439, 443, 445 could be otherwise shaped, arranged, and/or configured without departing from the disclosure.

[0054] As shown in FIGS. 9 and 9A, the handle features for forming the handles 410 in the carton 405 (FIG. 12) include a handle flap 473 foldably connected to each of the top end flaps 447, 449 along a respective arcuate fold line 475. The handle flaps 437 can be separable from the top end flaps 447, 449 along respective tear or cut lines 477. A fold line 479 can extend in each of the handle flaps 473. As shown in FIG. 9A, the fold line 479 is nonparallel with the arcuate fold line 475. For example, the fold line 479 can be a generally straight, longitudinal fold line. In an alternative embodiment, the fold line 475 could be generally straight, and the fold line 479 could be arcuate. Alternatively, the fold lines 475, 479 could be any suitable nonparallel or opposing arcuate fold lines. A grip portion 482 for contacting a hand of a user when grasping the handle generally can be defined between the arcuate fold line 475 and the nonparallel fold line 479 in each of the outer handle flaps 473. While the fold lines 475, 479 are nonparallel instead of opposing arcs like the fold lines 75, 79 of the outer handle flaps 73 of the first embodiment, the grip portions 482 generally can fold like the grip portions 82 of the first embodiment help provide a wider support area for a user's hands. Accordingly, the grip portions 482 can help make the material of the carton 405 at the handles 410 feel thicker and more comfortable for the user. In one embodiment, the handle flaps 473 each include a longitudinal score 481 extending in the grip portion 482.

[0055] In the illustrated embodiment, each of the handle flaps 473 can include oblique fold lines 483 and a lateral cut 485, which can form generally triangular flaps 487 that can

help accommodate the narrow top or neck of a container adjacent the respective handle 410. Accordingly, when the respective outer handle flap 473 is folded inwardly in the carton 405, the triangular flaps 487 can separate along the respective cuts 485 and fold outwardly along the oblique fold lines 483 upon contact with the narrow top of the respective container. The outer handle flaps 473 could be otherwise shaped, arranged, and/or configured without departing from the disclosure.

[0056] FIG. 10 illustrates an interior surface 602 of the reinforcing insert 604 for use in the carton 405. As illustrated in FIG. 10, the longitudinal axis L1 and the lateral axis L2 of the insert 604 are oriented to comport with the respective longitudinal axis L1 and lateral axis L2 of the carton blank 403 established in FIG. 9. In the illustrated embodiment, the insert 604 can be generally symmetric about a longitudinal central axis CL and a lateral or transverse central axis CT. The reinforcing insert 604 can include a central panel 608 and two reinforcing end flaps 612, 614 respectively foldably connected to the central panel 608 at opposite ends of the thereof. A first fold line 616 connects the first reinforcing end flap 612 to the central panel 608, and a second fold line 618 connects the second reinforcing end flap 614 to the central panel.

[0057] As shown in FIG. 10, the reinforcing insert 604 includes article retention or intermediate flaps 620 extending in the central panel 608 and the respective reinforcing end flap 612, 614. The intermediate flaps 620 are foldably connected to the central panel 608 along respective longitudinal fold lines 622 and are further defined by respective tear or cut lines 624. In one embodiment, the intermediate flaps 620 interrupt the respective fold lines 616, 618. The reinforcing insert 604 could be otherwise shaped, arranged, and/or configured without departing from the disclosure. For example, the insert 604 could include an inner dispenser for cooperating with the outer dispenser 545 of the carton blank 403. Alternatively, the inner dispenser could have features that are generally similar to the inner top panel 29 and the inner top end flaps 51, 53 of the blank 3 of the first embodiment, for example.

[0058] As shown in FIGS. 10 and 11, glue strips 626 can be applied to the interior surface 602 of the insert 604, and the insert can be positioned on the interior surface 402 of the carton blank 403 so that the central panel 608 generally overlaps the top panel 425 and the reinforcing end flaps 612, 614 generally overlap the respective top end flaps 447, 449. Accordingly, the central panel 608 and the reinforcing end flaps 612, 614 are glued to the respective top panel 425 and top end flaps 447, 449, while the intermediate flaps 620 generally are free to pivot along respective fold lines 622 relative to the carton blank 403. Alternatively, the insert 604 could be otherwise secured to the carton blank 403. As shown in FIG. 11, the longitudinal free edge 628 of the reinforcing end flap 612 is disposed adjacent at least a portion of the arcuate fold line 475 of the handle flap 473 in the top end flap 447, and the longitudinal free edge 630 of the reinforcing end flap 614 is disposed adjacent at least a portion of the arcuate fold line 475 of the handle flap 473 in the top end flap 449.

[0059] As shown in FIG. 11, the attachment flap 429 can be glued to the interior surface 402 of the carton blank 403, and the blank can be folded along the transverse fold lines 419, 423, 427, and 431 to form the open-ended sleeve 573 with an interior 575. The reinforcing insert 604 and the carton blank 403 could be otherwise formed into the open-ended sleeve using alternative folding and gluing steps without departing from the scope of the disclosure.

[0060] The side end flaps 437, 443 can be inwardly folded along the longitudinal fold line 461 to at least partially close the first end 407. In one embodiment the intermediate flap 620 at the first end 407 can be downwardly folded relative to the central panel 608 along fold line 622 so that the intermediate flap 620 is interior to the side end flaps 437, 443. As shown in FIG. 13, the intermediate flap 620 can extend at an oblique angle from the central panel 608 to the upper portions 503 of the side end flaps 437, 443. The top end flap 447 is folded along the longitudinal fold line 461 so that the top end flap 447 overlaps the side end flaps 437, 443 and the handle flap 473 is generally aligned with the openings 501. In one embodiment, the top end flap 447 is glued in face-to-face contact with the side end flaps 437, 443. The bottom end flap 433 is folded upwardly along the longitudinal fold line 461 into face-to-face contact with the lower portions of the side end flaps 437, 443. In one embodiment, the bottom end flap 433 overlaps a portion of the top end flap 447. The bottom end flap 433 can be glued to the side end flaps 437, 443 and/or the top end flap 447. Accordingly, the handle 410 in the first end 407 is formed by the alignment of the handle flap 473 of the top end flap 447 and the openings 501 of the side end flaps 437, 443. The top end flap 447, the side end flaps 437, 443, and the bottom end flap 433 can be selectively adhered to one another to close the first end 407 of the carton 405.

[0061] Containers can be loaded into the partially-erected carton 405 through the open second end 409. The second end 409 of the carton 405 can be closed in a similar manner as the first end 407 by folding, respectively overlapping, and selectively adhering the side end flaps 439, 445, the top end flap 449, and the bottom end flap 435. The erected carton is shown in FIG. 12, and the interior of the second end 409 is shown in FIG. 13. One or both of the ends 407, 409 could be otherwise shaped, arranged, configured, or omitted, without departing from the disclosure. Additionally, the open-ended sleeve 573 can be alternatively loaded with containers and closed without departing from the disclosure. For example, the ends 407, 409 can be closed in any order, and the containers could be loaded before or after closing either or both of the ends 407, 409.

[0062] The handles 410 can be used to grasp the carton 405 at each end 407, 409 similarly to the handles 10 of the first embodiment. As the handle flaps 473 are pressed inwardly through the handle openings 501 of the side end flaps 437, 439, 443, 445, the handle panels 473 can fold along the respective arcuate fold lines 475, 479. Accordingly, the grip portions 482 of the handle flaps 473 extend at an angle with respect to the top end flaps 447, 449 and the remainder of the handle flaps 473 to form hand contact areas 577 (FIG. 12). The hand contact areas 577 of the handles 410 can help to make the material of the carton 405 at the handles 410 feel like it is thicker than it is. Additionally, the hand contact areas 577 can provide a wider area that is supported by the user's hands, which is more comfortable than supporting the carton 405 along a single fold line. The nonparallel fold lines 475, 479 help avoid a situation where the weight of the carton 405 and the containers disposed therein is supported by a user's hands at a single fold line in each handle, which could more easily occur if each of the handle panels fold along a single fold line or along parallel fold lines.

[0063] Any of the features of the various embodiments of the disclosure can be combined with, replaced by, or otherwise configured with other features of other embodiments of the disclosure without departing from the scope of this dis-

closure. Further, it is noted that the handle flaps with the opposing arcuate fold lines or the nonparallel fold lines of the various embodiments can be incorporated into a carton having any carton style or panel configuration. The carton styles and panel configurations described above are included by way of example. Additionally, the shapes of the handle flaps can be substantially any shape. The shapes described above and included in the figures are included by way of example.

[0064] The blanks according to the present disclosure can be, for example, formed from coated paperboard and similar materials. For example, the interior and/or exterior sides of the blanks can be coated with a clay coating. The clay coating may then be printed over with product, advertising, price coding, and other information or images. The blanks may then be coated with a varnish to protect any information printed on the blank. The blanks may also be coated with, for example, a moisture barrier layer, on either or both sides of the blank. In accordance with the above-described embodiments, the blanks may be constructed of paperboard of a caliper such that it is heavier and more rigid than ordinary paper. The blanks can also be constructed of other materials, such as cardboard, hard paper, or any other material having properties suitable for enabling the carton to function at least generally as described herein. The blanks can also be laminated or coated with one or more sheet-like materials at selected panels or panel sections.

[0065] In accordance with the above-described embodiments of the present disclosure, a fold line can be any substantially linear, although not necessarily straight, form of weakening that facilitates folding therealong. More specifically, but not for the purpose of narrowing the scope of the present disclosure, fold lines include: a score line, such as lines formed with a blunt scoring knife, or the like, which creates a crushed portion in the material along the desired line of weakness; a cut that extends partially into a material along the desired line of weakness, and/or a series of cuts that extend partially into and/or completely through the material along the desired line of weakness; and various combinations of these features.

[0066] As an example, a tear line can include: a slit that extends partially into the material along the desired line of weakness, and/or a series of spaced apart slits that extend partially into and/or completely through the material along the desired line of weakness, or various combinations of these features. As a more specific example, one type tear line is in the form of a series of spaced apart slits that extend completely through the material, with adjacent slits being spaced apart slightly so that a nick (e.g., a small somewhat bridging-like piece of the material) is defined between the adjacent slits for typically temporarily connecting the material across the tear line. The nicks are broken during tearing along the tear line. The nicks typically are a relatively small percentage of the tear line, and alternatively the nicks can be omitted from or torn in a tear line such that the tear line is a continuous cut line. That is, it is within the scope of the present disclosure for each of the tear lines to be replaced with a continuous slit, or the like. For example, a cut line can be a continuous slit or could be wider than a slit without departing from the present disclosure.

[0067] The above embodiments may be described as having one or more panels adhered together by glue during erection of the carton embodiments. The term "glue" is intended to encompass all manner of adhesives commonly used to secure carton panels in place.

**[0068]** The foregoing description of the disclosure illustrates and describes various embodiments. As various changes could be made in the above construction without departing from the scope of the disclosure, it is intended that all matter contained in the above description or shown in the accompanying drawings shall be interpreted as illustrative and not in a limiting sense. Furthermore, the scope of the present disclosure covers various modifications, combinations, alterations, etc., of the above-described embodiments that are within the scope of the claims. Additionally, the disclosure shows and describes only selected embodiments of the disclosure, but the disclosure is capable of use in various other combinations, modifications, and environments and is capable of changes or modifications within the scope of the inventive concept as expressed herein, commensurate with the above teachings, and/or within the skill or knowledge of the relevant art. Furthermore, certain features and characteristics of each embodiment may be selectively interchanged and applied to other illustrated and non-illustrated embodiments of the disclosure.

What is claimed is:

1. A carton for holding a plurality of containers, the carton comprising:

a plurality of panels that extends at least partially around an interior of the carton;

at least one end flap foldably connected to at least one panel of the plurality of panels, the at least one end flap at least partially forming a closed end of the carton;

at least one handle comprising at least one handle flap foldably connected to the at least one end flap along a first fold line, the at least one handle flap comprising a grip portion at least partially defined by the first fold line and a second fold line extending in the at least one handle flap, wherein the first fold line and the second fold line are nonparallel.

2. The carton of claim 1, wherein the first fold line comprises an arcuate fold line and the second fold line comprises an opposing arcuate fold line that generally mirrors the arcuate fold line.

3. The carton of claim 2, wherein at least one end of the opposing arcuate fold line is spaced apart from the arcuate fold line.

4. The carton of claim 2, wherein a score line extends in the grip portion and is spaced apart from the arcuate fold line and the opposing arcuate fold line.

5. The carton of claim 1, wherein the first fold line comprises an arcuate fold line and the second fold line comprises a generally straight fold line.

6. The carton of claim 5, wherein a score line extends in the grip portion and is spaced apart from the arcuate fold line and the generally straight fold line.

7. The carton of claim 1, wherein:

the at least one end flap comprises an outer top end flap at least partially overlapping an inner top end flap;

the at least one handle comprises an outer handle flap foldably connected to the outer top end flap, and the at least one handle further comprises an inner handle flap foldably connected to the inner top end flap; and  
the outer handle flap at least partially overlaps the inner handle flap.

8. The carton of claim 7, wherein the inner handle flap is foldably connected to the inner top end flap along a third fold line, the inner handle flap comprises a folding portion at least partially defined by the third fold line and a fourth fold line

extending in the inner handle flap, and the grip portion of the outer handle flap at least partially overlaps the folding portion of the inner handle flap.

9. The carton of claim 8, wherein the third fold line and the fourth fold line are nonparallel.

10. The carton of claim 8, wherein each of the first fold line and the third fold line comprises an arcuate fold line, and each of the second fold line and the fourth fold line comprises an opposing arcuate fold line that generally mirrors the respective arcuate fold line.

11. The carton of claim 7, wherein the at least one end flap further comprises at least one side end flap, the outer top end flap and the inner top end flap at least partially overlap the at least one side end flap, and the at least one handle further comprises at least one side handle flap foldably connected to the at least one side end flap adjacent a handle opening formed in the at least one side end flap, the outer handle flap and the inner handle flap being at least partially aligned with the at least one side handle flap.

12. The carton of claim 11, wherein the at least one side end flap comprises a first side end flap and a second side end flap, the at least one side handle flap comprises a first side handle flap foldably connected to the first side end flap and a second side handle flap foldably connected to the second side end flap, and the first side handle flap at least partially overlaps the second side handle flap.

13. The carton of claim 1, wherein the at least one end flap comprises a top end flap at least partially overlapping a side end flap, the at least one handle flap is foldably connected to the top end flap along the first fold line, the at least one handle comprises a handle opening formed in the side end flap, and the at least one handle flap is at least partially aligned with the handle opening.

14. The carton of claim 13, wherein the at least one handle further comprises a side handle flap foldably connected to the side end flap adjacent the handle opening formed in the side end flap, the at least one handle flap at least partially overlapping the side handle flap.

15. The carton of claim 1, wherein the plurality of panels comprises a top panel and the at least one end flap comprises a top end flap foldably connected to the top panel, the carton further comprises a reinforcing insert at least partially in face-to-face contact with the top panel, the reinforcing insert comprises a reinforcing end flap at least partially in face-to-face contact with the top end flap, and the reinforcing end flap comprises a free edge disposed adjacent the first fold line of the at least one handle.

16. The carton of claim 15, wherein the at least one end flap further comprises a side end flap, the top end flap and the reinforcing end flap at least partially overlap the side end flap, and the reinforcing insert comprises an intermediate flap at least partially defined by a cut extending in at least the reinforcing end flap, the intermediate flap extending obliquely between the top panel and an interior surface of the side end flap.

17. A blank for forming a carton for holding a plurality of containers, the blank comprising:

a plurality of panels;

at least one end flap foldably connected to at least one panel of the plurality of panels, the at least one end flap being for at least partially forming a closed end of the carton formed from the blank;

handle features for forming at least one handle, the handle features comprising at least one handle flap foldably

connected to the at least one end flap along a first fold line, the at least one handle flap comprising a grip portion at least partially defined by the first fold line and a second fold line extending in the at least one handle flap, wherein the first fold line and the second fold line are nonparallel.

**18.** The blank of claim **17**, wherein the first fold line comprises an arcuate fold line and the second fold line comprises an opposing arcuate fold line that generally mirrors the arcuate fold line.

**19.** The blank of claim **18**, wherein at least one end of the opposing arcuate fold line is spaced apart from the arcuate fold line.

**20.** The blank of claim **18**, wherein a score line extends in the grip portion and is spaced apart from the arcuate fold line and the opposing arcuate fold line.

**21.** The blank of claim **17**, wherein the first fold line comprises an arcuate fold line and the second fold line comprises a generally straight fold line.

**22.** The blank of claim **21**, wherein a score line extends in the grip portion and is spaced apart from the arcuate fold line and the generally straight fold line.

**23.** The blank of claim **17**, wherein:

the at least one end flap comprises an outer top end flap and an inner top end flap, the outer top end flap being for at least partially overlapping the inner top end flap when the carton is formed from the blank;

the at least one handle flap comprises an outer handle flap foldably connected to the outer top end flap, and the at least one handle further comprises an inner handle flap foldably connected to the inner top end flap; and

the outer handle flap is for at least partially overlapping the inner handle flap when the carton is formed from the blank.

**24.** The blank of claim **23**, wherein the inner handle flap is foldably connected to the inner top end flap along a third fold line, the inner handle flap comprises a folding portion at least partially defined by the third fold line and a fourth fold line extending in the inner handle flap, and the grip portion of the outer handle flap being for at least partially overlapping the folding portion of the inner handle flap when the carton is formed from the blank.

**25.** The blank of claim **24**, wherein the third fold line and the fourth fold line are nonparallel.

**26.** The blank of claim **24**, wherein each of the first fold line and the third fold line comprises an arcuate fold line, and each of the second fold line and the fourth fold line comprises an opposing arcuate fold line that generally mirrors the respective arcuate fold line.

**27.** The blank of claim **23**, wherein the at least one end flap further comprises at least one side end flap, the at least one handle further comprises at least one side handle flap foldably connected to the at least one side end flap adjacent a handle opening formed in the at least one side end flap, the outer top end flap and the inner top end flap are for at least partially overlapping the at least one side end flap when the carton is formed from the blank, and the outer handle flap and the inner handle flap are for being at least partially aligned with the at least one side handle flap when the carton is formed from the blank.

**28.** The blank of claim **27**, wherein the at least one side end flap comprises a first side end flap and a second side end flap, the at least one side handle flap comprises a first side handle flap foldably connected to the first side end flap and a second

side handle flap foldably connected to the second side end flap, and the first side handle flap is for at least partially overlapping the second side handle flap when the carton is formed from the blank.

**29.** The blank of claim **17**, wherein the at least one end flap comprises a top end flap and a side end flap, the at least one handle flap is foldably connected to the top end flap along the first fold line, the at least one handle comprises a handle opening formed in the side end flap, and the at least one handle flap is for being at least partially aligned with the handle opening when the carton is formed from the blank.

**30.** The blank of claim **29**, wherein the at least one handle further comprises a side handle flap foldably connected to the side end flap adjacent the handle opening formed in the side end flap, and the at least one handle flap is for at least partially overlapping the side handle flap when the carton is formed from the blank.

**31.** The blank of claim **17**, wherein the plurality of panels comprises a top panel and the at least one end flap comprises a top end flap foldably connected to the top panel, a reinforcing insert is disposed at least partially in face-to-face contact with the top panel, the reinforcing insert comprises a reinforcing end flap at least partially in face-to-face contact with the top end flap, and the reinforcing end flap comprises a free edge disposed adjacent the first fold line of the at least one handle.

**32.** The blank of claim **31**, wherein the at least one end flap further comprises a side end flap, the reinforcing insert comprises an intermediate flap at least partially defined by a cut extending in at least the reinforcing end flap, the top end flap and the reinforcing end flap are for at least partially overlapping the side end flap when the carton is formed from the blank, and the intermediate flap is for being positioned to extend obliquely between the top panel and an interior surface of the side end flap when the carton is formed from the blank.

**33.** A method of forming a carton for holding a plurality of containers, the method comprising:

obtaining a carton comprising a plurality of panels that extends at least partially around an interior of the carton, at least one end flap foldably connected to at least one panel of the plurality of panels, the at least one end flap at least partially forming a closed end of the carton, and at least one handle comprising at least one handle flap foldably connected to the at least one end flap along a first fold line, the at least one handle flap comprising a grip portion at least partially defined by the first fold line and a second fold line extending in the at least one handle flap, wherein the first fold line and the second fold line are nonparallel;

actuating the at least one handle by folding the at least one handle flap along the first fold line and the second fold line.

**34.** The method of claim **33**, wherein the folding the at least one handle flap comprises positioning the grip portion to be generally horizontal with respect to the at least one end flap and positioning a remainder of the at least one handle flap to extend generally upwardly from the grip portion.

**35.** The method of claim **33**, wherein the first fold line comprises an arcuate fold line and the second fold line comprises an opposing arcuate fold line that generally mirrors the arcuate fold line.

**36.** The method of claim **33**, wherein the first fold line comprises an arcuate fold line and the second fold line comprises a generally straight fold line.

**37.** The method of claim **33**, wherein:

the at least one end flap comprises an outer top end flap at least partially overlapping an inner top end flap;

the at least one handle flap comprises an outer handle flap foldably connected to the outer top end flap along the first fold line, and the at least one handle further comprises an inner handle flap foldably connected to the inner top end flap along a third fold line, the outer handle flap at least partially overlapping the inner handle flap; and

the actuating the at least one handle further comprises folding the inner handle flap along the third fold line.

**38.** The method of claim **37**, wherein the inner handle flap comprises a folding portion at least partially defined by the third fold line and a fourth fold line extending in the inner handle flap, the third fold line and the fourth fold line are nonparallel, the grip portion of the outer handle flap at least

partially overlaps the folding portion of the inner handle flap, and the actuating the at least one handle further comprises folding the inner handle flap along the fourth fold line.

**39.** The method of claim **37**, wherein the at least one end flap further comprises at least one side end flap, the outer top end flap and the inner top end flap at least partially overlap the at least one side end flap, the at least one handle further comprises at least one side handle flap foldably connected to the at least one side end flap adjacent a handle opening formed in the at least one side end flap, the outer handle flap and the inner handle flap being at least partially aligned with the at least one side handle flap, and the actuating the at least one handle further comprises folding the outer handle flap and the inner handle flap at least partially through the handle opening and folding the side handle flap relative to the at least one side end flap.

\* \* \* \* \*