



US010841675B2

(12) **United States Patent**
Howard et al.

(10) **Patent No.:** **US 10,841,675 B2**
(45) **Date of Patent:** **Nov. 17, 2020**

- (54) **LOUDSPEAKERS AND RELATED COMPONENTS AND METHODS**
- (71) Applicant: **Bose Corporation**, Framingham, MA (US)
- (72) Inventors: **Raymond Thomas Howard**, Franklin, MA (US); **Michaela Freed**, Watertown, MA (US)
- (73) Assignee: **Bose Corporation**, Framingham, MA (US)
- (*) Notice: Subject to any disclaimer, the term of this patent is extended or adjusted under 35 U.S.C. 154(b) by 0 days.

5,113,968 A *	5/1992	Lemmon	H04R 1/023
				181/148
5,412,162 A *	5/1995	Kindel	H04R 1/023
				181/150
6,056,083 A *	5/2000	Daniell	H04R 5/02
				181/144
6,993,145 B2 *	1/2006	Combest	H04R 1/023
				181/199
7,346,181 B2 *	3/2008	Rivera	H04R 1/023
				381/391
7,760,900 B2 *	7/2010	Kemmerer	H04R 1/023
				381/386
8,112,130 B2 *	2/2012	Mittleman	H04M 1/035
				455/575.1
8,437,493 B2 *	5/2013	Nho	H04M 1/035
				381/386
8,488,817 B2 *	7/2013	Mittleman	H04M 1/035
				381/189

(21) Appl. No.: **16/217,193**

(Continued)

(22) Filed: **Dec. 12, 2018**

FOREIGN PATENT DOCUMENTS

(65) **Prior Publication Data**
US 2020/0196037 A1 Jun. 18, 2020

DE	2404943 A1 *	8/1975	H04R 1/222
JP	11004493 A *	1/1999		
KR	20100050856 A *	5/2010		

(51) **Int. Cl.**
H04R 1/02 (2006.01)
H04R 1/44 (2006.01)

(52) **U.S. Cl.**
CPC **H04R 1/023** (2013.01); **H04R 1/025** (2013.01); **H04R 1/44** (2013.01)

Primary Examiner — Fan S Tsang
Assistant Examiner — Ryan Robinson
(74) *Attorney, Agent, or Firm* — Bose Corporation

(58) **Field of Classification Search**
CPC H04R 1/023
USPC 381/391
See application file for complete search history.

(57) **ABSTRACT**

A loudspeaker includes an acoustic enclosure, and an electro-acoustic transducer that is supported by the acoustic enclosure. A grille covers the electro-acoustic transducer, and a weather-resistant member is disposed between the acoustic enclosure and the grille. A spring member is disposed between the weather-resistant member and the acoustic enclosure. The spring member is configured to apply a force to the weather-resistant layer thereby to hold the weather-resistant member against the grille.

(56) **References Cited**
U.S. PATENT DOCUMENTS

3,938,618 A * 2/1976 Ambruoso, Sr. H04R 1/023
181/155

4,974,698 A * 12/1990 Smith H04R 1/023
181/150

25 Claims, 4 Drawing Sheets

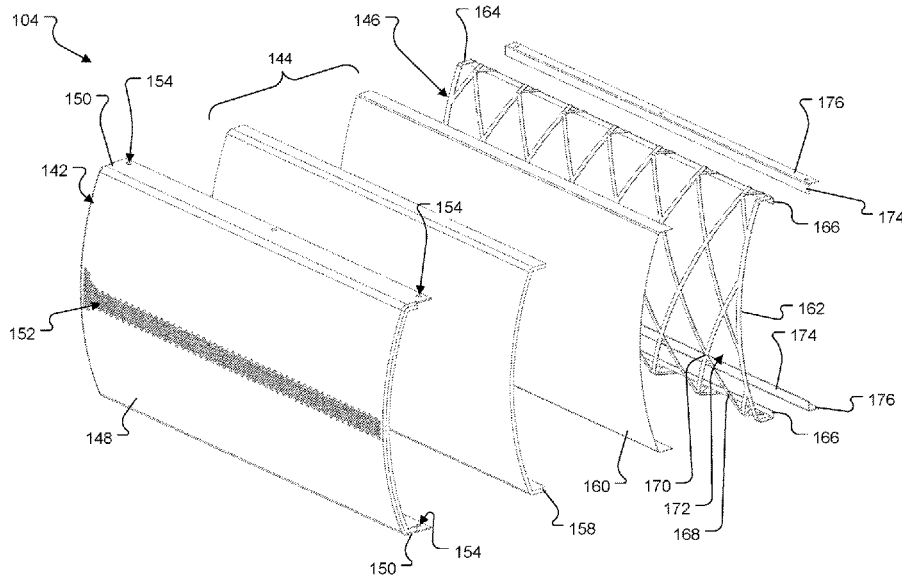

(56)

References Cited

U.S. PATENT DOCUMENTS

9,014,411	B2 *	4/2015	Rodgers	H04R 1/023 381/391
9,414,141	B2 *	8/2016	Cohen	H04M 1/03
9,538,272	B2 *	1/2017	Auclair	G10K 11/18
9,820,033	B2 *	11/2017	Dix	H04R 1/2826
10,132,004	B2 *	11/2018	Lee	H04R 1/023
10,356,497	B1 *	7/2019	Brown	H04R 1/023
2002/0054978	A1 *	5/2002	Holmberg	H04R 1/023 428/99
2015/0172798	A1 *	6/2015	Chao	H04R 1/023 381/334
2017/0230739	A1 *	8/2017	Soofer	H04R 1/025

* cited by examiner

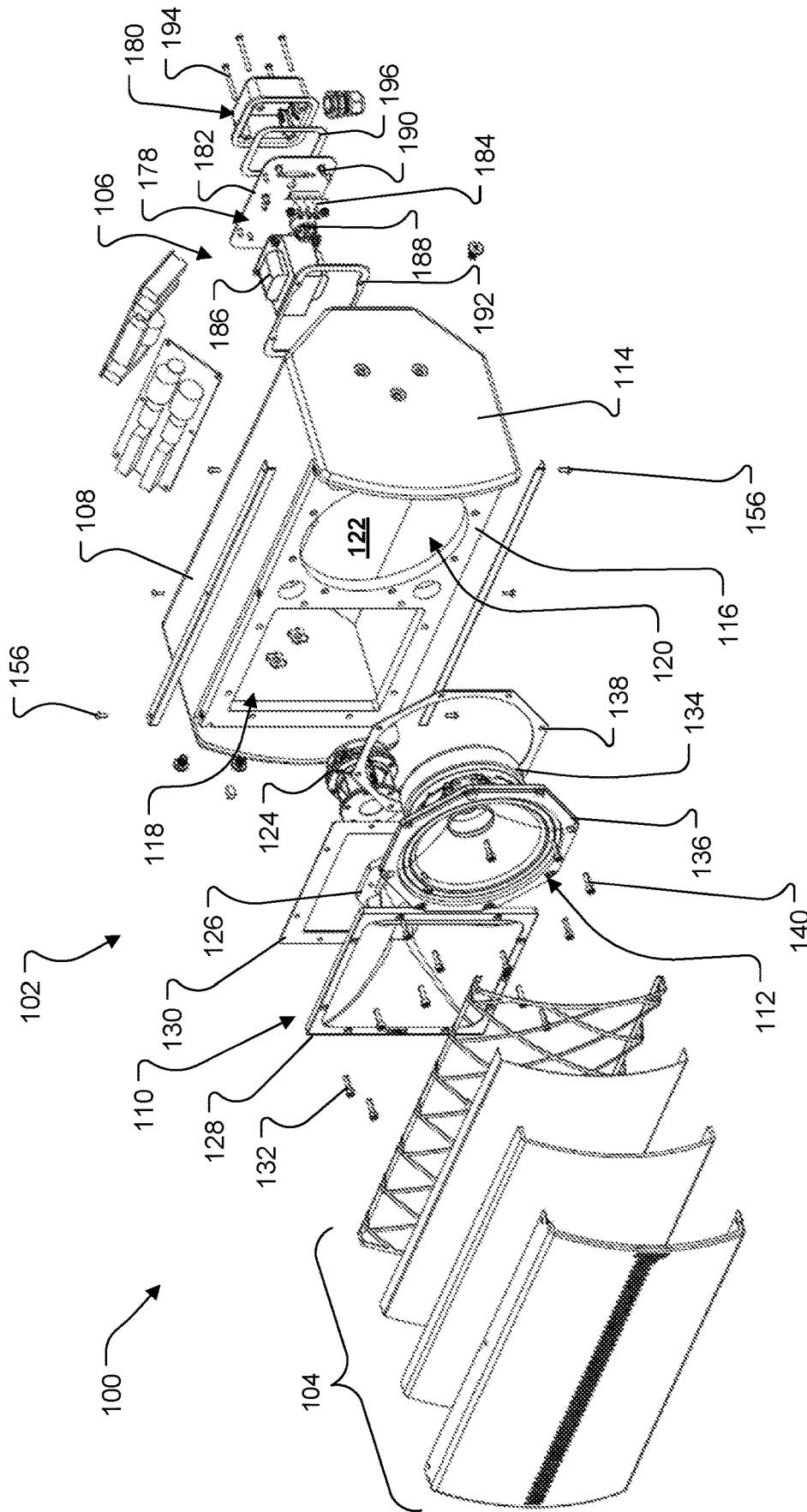

FIG. 1A

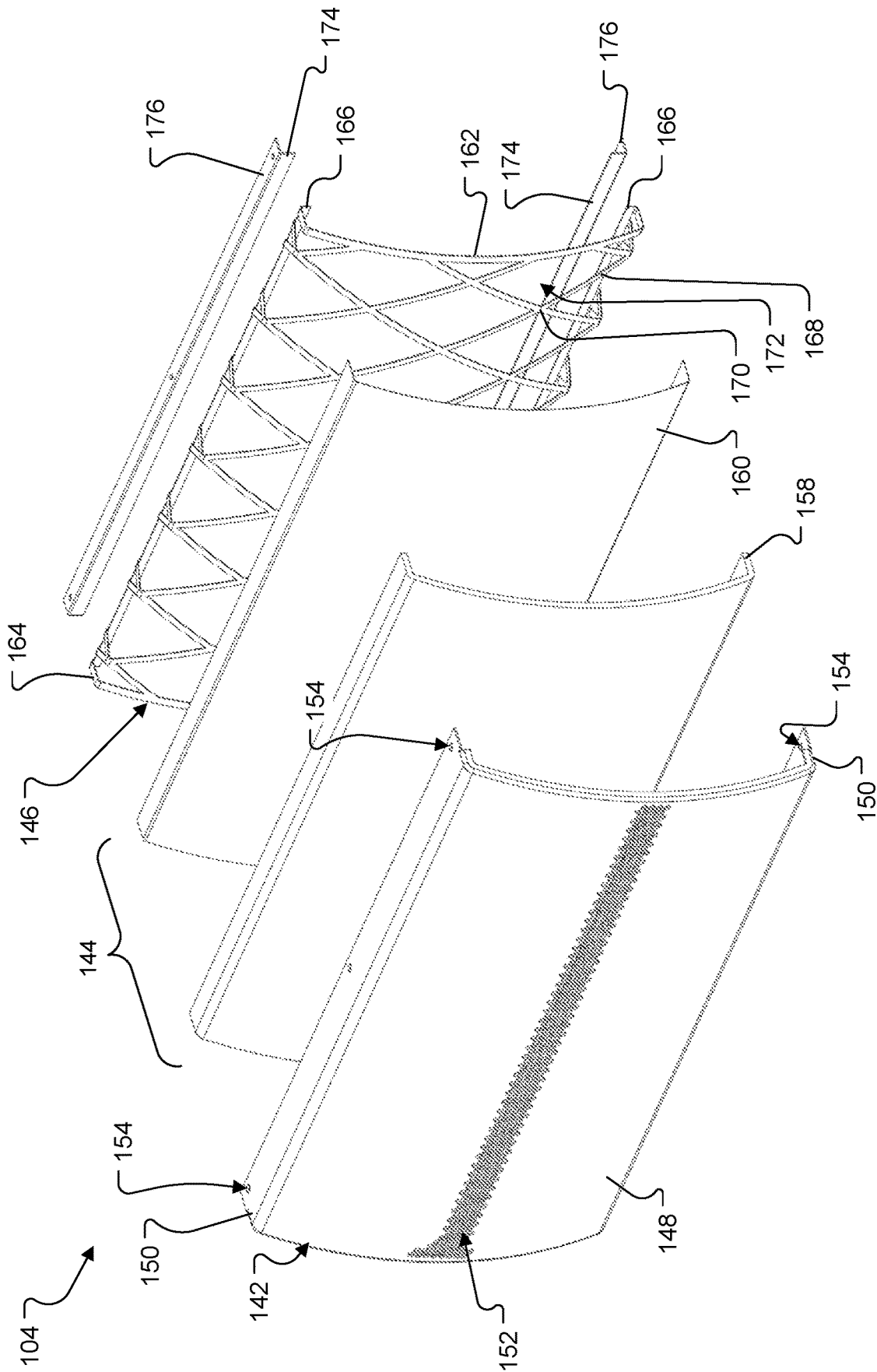

FIG. 1B

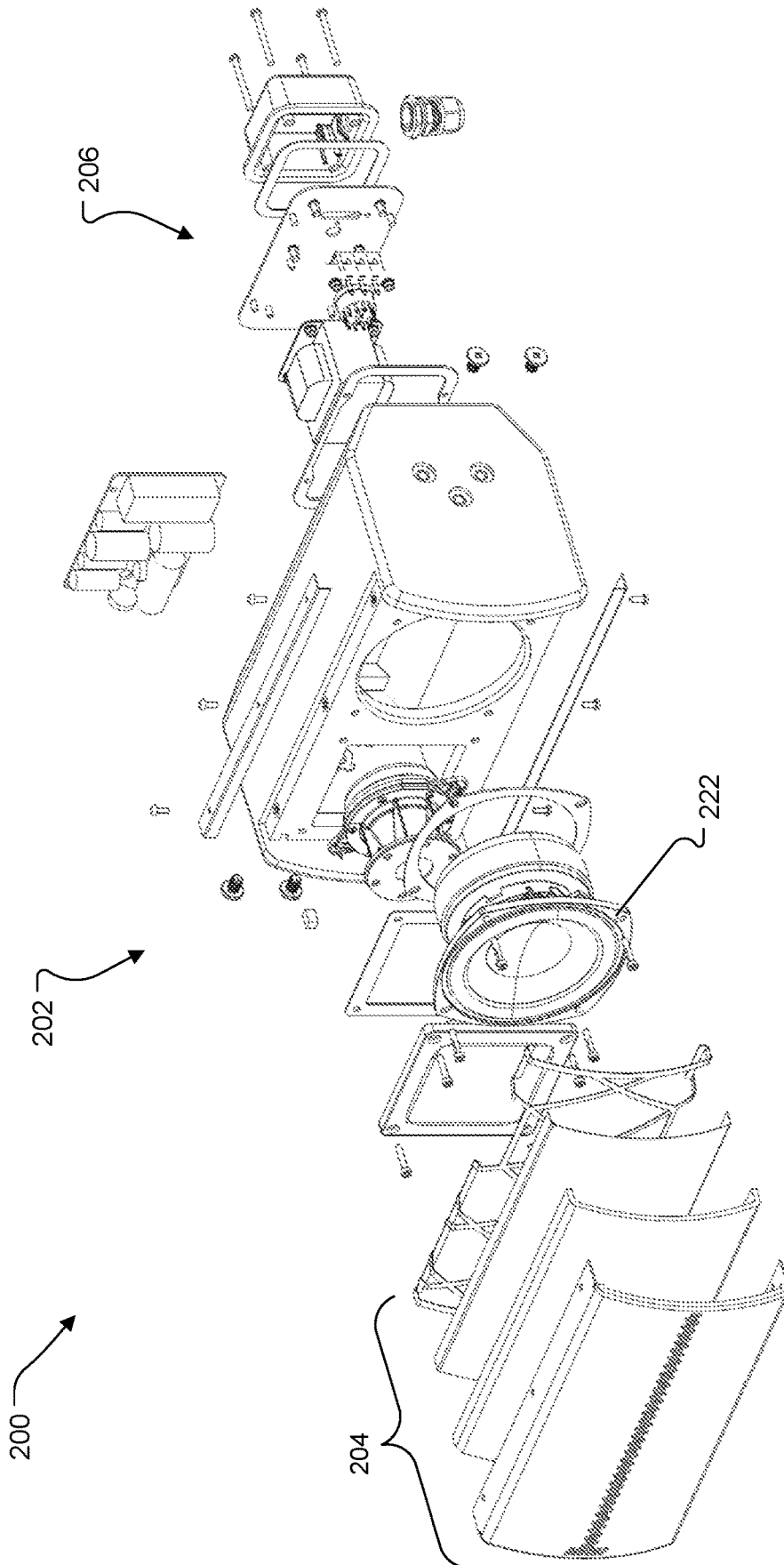

FIG. 2A

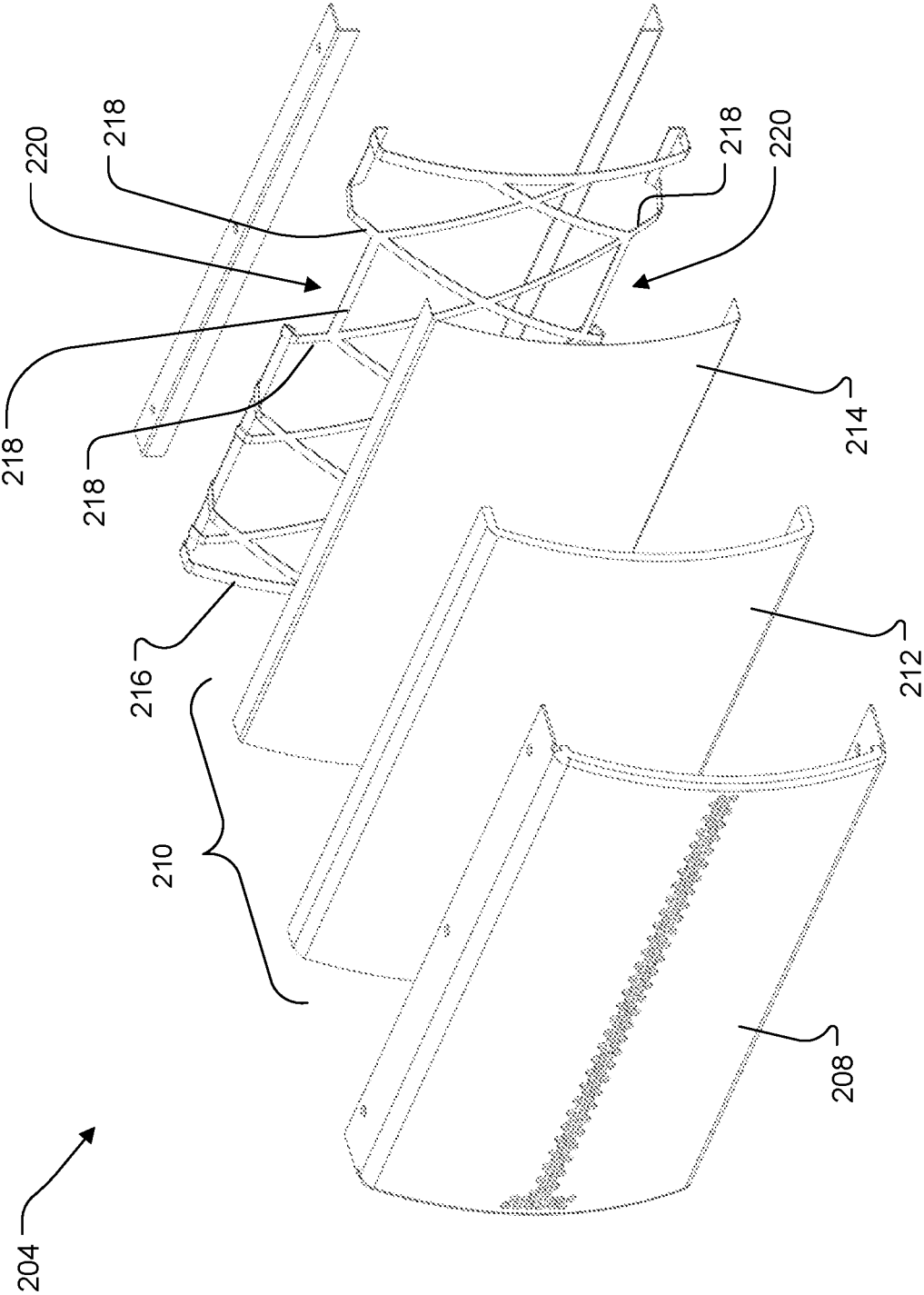

FIG. 2B

LOUDSPEAKERS AND RELATED COMPONENTS AND METHODS

BACKGROUND

This disclosure relates to a loudspeaker, and, more particularly, to a loudspeaker having a weather-resistant grille assembly.

SUMMARY

All examples and features mentioned below can be combined in any technically possible way.

In one aspect, a loudspeaker includes an acoustic enclosure, and an electro-acoustic transducer that is supported by the acoustic enclosure. A grille covers the electro-acoustic transducer, and a weather-resistant member is disposed between the acoustic enclosure and the grille. A spring member is disposed between the weather-resistant member and the acoustic enclosure. The spring member is configured to apply a force to the weather-resistant layer thereby to hold the weather-resistant member against the grille.

Implementations may include one of the following features, or any combination thereof.

In some implementations, the weather-resistant member includes a scrim layer. The scrim layer may be formed of an acoustically transparent sheet form foam material.

In certain implementations, the spring member includes a substantially arcuate main body that extends between a pair of opposing sidewalls.

In some examples, the substantially arcuate main body is biased outwardly, away from the acoustic enclosure, such that a concave side of the main body faces toward the housing.

In certain examples, the arcuate main body includes a plurality of cross-members.

In some cases, the cross-members extend diagonally relative to the sidewalls.

In certain cases, the cross-members intersect with each other at nodes.

In some implementations, the cross-members are arranged to form a notch to accommodate the geometry of the electro-acoustic transducer.

In certain implementations, the weather-resistant layer includes a screen layer disposed between the spring member and the scrim layer. The spring member may be configured to apply a force to the screen layer to hold a front surface of the screen layer against a rear surface of the scrim layer and to hold a front surface of the scrim layer against a rear surface of the grille.

In some examples, the weather-resistant member consists of a screen layer.

In certain examples, the screen layer includes an acoustically transparent sheet form material formed of a woven fabric. The woven fabric may be formed of metal filaments. In some cases, the screen layer may be formed of cloth.

Another aspect provides a grille assembly for a loudspeaker. The grille assembly includes a grille, a spring member, and a weather-resistant member disposed between the spring member and the grille. The spring member is configured to apply a force between an acoustic enclosure of a loudspeaker and the weather-resistant layer to hold a front surface of the weather-resistant member substantially flush against a rear surface of the grille.

Implementations may include one of the above and/or below features, or any combination thereof.

In some implementations, the weather-resistant member includes a scrim layer.

In certain implementations, the scrim layer is formed of an acoustically transparent sheet form foam material.

In some examples, the spring member includes a substantially arcuate main body that extends between a pair of opposing sidewalls.

In certain examples, the sidewalls terminate at a pair of feet, which are arranged to rest against a surface of an acoustic enclosure of a loudspeaker.

In some cases, the substantially arcuate main body is biased outwardly, away from the acoustic enclosure, such that a concave side of the main body faces toward the housing.

In certain cases, the arcuate main body includes a plurality of cross-members.

In some implementations, the cross-members extend diagonally relative to the sidewalls.

In certain implementations, the cross-members intersect with each other at nodes.

In some examples, the cross-members are arranged to form a notch to accommodate the geometry of an electro-acoustic transducer of the loudspeaker.

In certain examples, the weather-resistant layer includes a screen layer disposed between the spring member and the scrim layer. The spring member may be configured to apply a force to the screen layer to hold a front surface of the screen layer against a rear surface of the scrim layer and to hold a front surface of the scrim layer against a rear surface of the grille.

In some cases, the weather-resistant member consists of a screen layer.

In certain cases, the screen layer comprises an acoustically transparent sheet form material formed of a woven fabric of metal filaments.

BRIEF DESCRIPTION OF THE DRAWINGS

FIG. 1A is an exploded perspective view of a first implementation of a loudspeaker.

FIG. 1B is an exploded perspective view of a grille assembly from the loudspeaker of FIG. 1A.

FIG. 2A is an exploded perspective view of a second implementation of a loudspeaker.

FIG. 2B is an exploded perspective view of a grille assembly from the loudspeaker of FIG. 2A.

DETAILED DESCRIPTION

This disclosure is based, at least in part, on the realization that it can be beneficial to provide structural support to a scrim backing layer in a weather-resistant loudspeaker.

With reference to FIG. 1A, a loudspeaker **100** includes an acoustic assembly **102**, a grille assembly **104**, and an input/output (I/O) assembly **106**. Notably the grille assembly **104** is configured to be weather-resistant, thereby to protect components of the acoustic assembly **102** from moisture to enable outdoor use of the loudspeaker **100**.

Acoustic Assembly

The acoustic assembly **102** includes an acoustic enclosure **108** and a plurality of electro-acoustic transducers **110**, **112**, which are supported by the acoustic enclosure **108**. The acoustic enclosure **108** includes a cabinet **114** and a baffle **116**. The cabinet **114** and the baffle **116** may be formed of a rigid material such as metal, hard plastic, wood (e.g., plywood), or fiber board (e.g., medium-density fiberboard (MDF)). The baffle **116** includes a plurality of openings **118**,

120 for receiving the electro-acoustic transducers **110**, **112**. The cabinet **114** and the baffle **116** together define an acoustic cavity **122**.

In the illustrated example, the electro-acoustic transducers **110**, **112** include a high-frequency (HF) transducer **110** and a low-frequency (LF) transducer **112**. The HF transducer **110** includes a compression driver **124** that is coupled a throat of a horn **126**. The compression driver **124** is passed through a first opening **118** in the baffle **116** and is received within the acoustic cavity **122**. A mouth of the horn **126** is secured to the baffle **116** via a frame **128** that surrounds the mouth. A gasket **130** is disposed between the frame **128** and the baffle **116** to inhibit buzz and provide an acoustic seal between the frame **128** and the acoustic cavity **122**. The frame **128** is secured to the baffle **116** with fasteners **132**.

An electro-magnetic motor **134** of the LF transducer **112** is passed through a second opening **120** in the baffle **116** and is received within the acoustic cavity **122**. The LF transducer **112** is secured to the baffle **116** via a frame **136**. A gasket **138** is disposed between the frame **136** and the baffle **116** to inhibit buzz and provide an acoustic seal between the frame **136** and the acoustic cavity **122**. The frame **136** is secured to the baffle **116** with fasteners **140**. The LF transducer **112** is arranged such that a rear radiating surface of the LF transducer **112** radiates acoustic energy into the acoustic cavity **122**.

Grille Assembly

Referring to FIG. 1B, the grille assembly **104** includes a grille **142**, a weather-resistant member **144**, and a spring member **146**. The grille **142** has a substantially arcuate main body **148** that extends between a pair of opposing sidewalls **150**. The main body **148** includes a plurality of apertures **152** that allow acoustic energy, radiated by the electro-acoustic transducers **110**, **112** to pass through the grille **142**. The sidewalls **150** include a plurality of mounting holes **154** for receiving fasteners **156** (FIG. 1A) for securing the grille **154** to the acoustic enclosure **108** (FIG. 1A). The grille **142** can be formed of a rigid material such as a metal (e.g., stainless steel) or hard plastic.

The weather-resistant member **144** is a sheet form material that overlies the apertures **152** along a rear surface of the grille **142**. The weather-resistant member **144** is acoustically transparent and is configured to inhibit water and dust from entering. In that regard, the apertures **152** may allow water to pass through the grille **142**. This is more likely when the loudspeaker **100** is mounted outdoors and is subject to the elements include, for example, driving rain. The weather-resistant member **144** is configured to inhibit (e.g., prevent) water that passes through the grille **142** from reaching the electro-acoustic transducers **110**, **112**. In some cases, the weather-resistant member **144** is configured to enable the loudspeaker **100** to pass IPX testing, which tests against driven water and dust). In some implementations, the loudspeaker is weather-resistant beyond a minimum IPX rating of IPX IP55.

In the illustrated example, the weather-resistant member **144** includes a scrim layer **158** and a screen layer **160**. The scrim layer **158** is a first barrier against water and dust infiltration. The scrim layer **158** may be formed from a sheet form foam material, such as a polyethylene foam. One suitable material for the scrim layer **158** is 60 PPI fireproof polyethylene foam with a thickness of 2 mm to 10 mm, e.g., 4 mm thickness. The screen layer **160** is second barrier against water and dust infiltration. In some cases, the screen layer **160** may help to ensure that forces applied to rear surface of the scrim layer **158** (as described below) are more evenly distributed. The screen layer **160** is another acousti-

cally transparent sheet form material and may be formed of a woven fabric of metal filaments (e.g., 316H stainless steel woven wire mesh).

A front surface of the scrim layer **158** rests against a rear surface of the grille **142**, and a front surface of the screen layer **160** rests against a rear surface of the scrim layer **158**. Prolonged exposure to the elements, such as wind and rain, might cause the weather-resistant member **144** to sag. The sagging of the weather-resistant member **144** might result in flapping, i.e., movement of the member **144** during use, which might result undesirable acoustic effects. For example, the weather-resistant member **144** could be forced against the electro-acoustic transducers and thereby affect acoustics. Sagging of the weather-resistant member **144** might also allow water to pool between the grille **142** and the weather-resistant member **144**, which might ultimately contribute to failure of the weather-resistant member **144**. In some instances, the weather-resistant member **144** also serves as a cosmetic backing to the grille **142**, and sagging might degrade the cosmetic appearance of the loudspeaker **100**.

In some cases, adhesives may be used to secure the water-resistant member **144** to the grille **142**. For example, the scrim layer **158** may be secured to the grille **142** with an adhesive. Alternatively or additionally, the screen layer **160** may be secured to the scrim layer **158** with an adhesive. However, with prolonged exposure to the elements, adhesives can fail. As a result, adhesives alone might only help to delay, but not prevent, sagging of the water-resistant member **144**. Adhesives might also occlude pores and openings in the water-resistant member **144**, which can adversely affect the acoustic transparency of the water-resistant member **144**.

The spring member **146** is configured to provide prolonged protection against sag. The spring member **146** includes a substantially arcuate main body **162** that extends between a pair of opposing sidewalls **164**, which terminate at a pair of feet **166**. The curvature of the main body **162** of the spring member **146** conforms generally to that of the main body **148** (FIG. 1) of the grille **142**. The arcuate main body **162** includes a plurality of cross-members **168**, which extend diagonally relative to the sidewalls **164**. The cross-members **168** intersect with each other at nodes **170**. Open regions **172** between the cross-members **168** allow for acoustic energy radiate by the electro-acoustic transducers to pass therethrough.

Preferably, the spring member **146** is designed such that the cross-members **168** and nodes **170** are spaced away from the motion axes of the electro-acoustic transducers **110**, **112** (FIG. 1A), e.g., such that respective ones of the open regions **172** are centered along the motion axes of the electro-acoustic transducers **110**, **112**.

The cross-members **168** have a width (w) of 5 mm or less (e.g., 4 mm-5 mm). Cross-members with a width greater than 5 mm can undesirably interfere with audible frequencies produced by the electro-acoustic transducers **110**, **112**. The spring member **146** can be formed of metal, such as stainless steel. In one example, the spring member **146** is formed from a sheet of stainless steel that is punched to form the cross-members, and bend to shape to impart a curvature to the main body **162** and to form the sidewalls **164** and feet **166**.

The main body **162** extends along a rear surface of the water-resistant member **144**. The substantially arcuate main body **162** is biased outwardly, away from the acoustic enclosure **108**, such that a concave side the main body **162**

faces toward the acoustic enclosure **108** and an opposite, convex side faces toward the concave inner surface of the grille **142**.

The feet **166** sit on the acoustic enclosure **108** (FIG. 1A) and allow for the main body **162** of the spring member **146** to apply a force to the rear surface of the water-resistant member **144**. A gasket **174** (e.g., an ethylene-vinyl acetate (EVA) gasket) may be disposed between the feet **166** and the acoustic enclosure **108** to help inhibit buzz.

The grille **142** is coupled to the acoustic enclosure **108** (FIG. 1A) via fasteners **156** (FIG. 1A), thereby securing the spring member **146** between the grille **142** and the acoustic enclosure **108** and sandwiching the water-resistant member **144** between the grille **142** and the spring member **146**. When assembled, the spring member **146** applies a compressive force along the rear surface of the water-resistant member **144**, thereby to hold a front surface of the water-resistant member **144** in close contact with the rear surface of the grille **142**. In that regard, following assembly, the spring member **146** compresses the water-resistant member **144** between 0.5 mm and 2 mm (e.g., between 10% and 25% of its uncompressed thickness).

As a result, the spring member **146** helps to ensure that the water-resistant member **144** remains in close contact with the grille **142** even after prolonged exposure to the elements, thereby reducing the likelihood of sagging and the resulting flapping, potential loss of water-resistance, and deteriorated cosmetic appearance. The inclusion of the spring member **146** can also alleviate the need for adhesives on the surfaces of the water-resistant member **144** which can occlude openings and adversely affect the acoustic transparency of the water-resistant member **144**.

A gasket **176** (e.g., an ethylene-vinyl acetate (EVA) gasket) may be disposed between the grille **142** and the acoustic enclosure **108** (FIG. 1A) to inhibit buzz. In some implementations, the gasket **174** (between the spring member **146** and the acoustic enclosure **108**) and the gasket **176** (between the grille **142** and the acoustic enclosure **108**) may be formed from one piece of material. For example, a single strip of gasket material may be folded along its length to provide a first gasket portion to sit between the spring member **146** and the acoustic enclosure **108**, and a second gasket portion to sit between the grille **142** and the acoustic enclosure **108**.

I/O Assembly

Referring again to FIG. 1, the I/O assembly **106** is mounted to a rear surface of the acoustic enclosure **108** for coupling electrical wires (not shown) to power the electro-acoustic transducers **110**, **112**. The I/O assembly **106** includes an I/O panel **178** and an I/O cover **180**. The I/O panel **178** includes a mounting plate **182** that supports a terminal strip **184**, a transformer **186**, and a selector switch **188**. The terminal strip **184** allows electrical wires to be connected to the loudspeaker **100** to power the electro-acoustic transducers **110**, **112** (i.e., via an opening, not shown, in a rear surface the acoustic enclosure **108**). The selector switch **188** can be a rotary switch from selecting among the multiple taps of the transformer **186**.

The mounting plate **182** is secured to the acoustic enclosure **108** via fasteners **190**. A gasket **192** (e.g., an ethylene-vinyl acetate (EVA) gasket) is disposed between the mounting plate **182** and the acoustic enclosure **108** to provide a water-resistant seal. The gasket **192** can also help to provide an acoustic seal (e.g., to inhibit leakage of acoustic energy from the acoustic enclosure **108**), and inhibit buzz (e.g., between the acoustic enclosure **108** and the mounting plate **182**).

The I/O cover **180** provides water-resistant protection for the terminal strip **184** and may formed as a molded plastic part. The I/O cover **180** is secured to the mounting plate **182** with fasteners **194**. A gasket **196** (e.g., an ethylene-vinyl acetate (EVA) gasket) provides a water-resistant seal between the I/O cover **180** and the mounting plate **182** and can also help to inhibit buzz therebetween.

Other Implementations

While one or more implementations of a loudspeaker have been described above, other implementations are possible. For example, FIG. 2A illustrates another loudspeaker **200**. The loudspeaker **200** includes an acoustic assembly **202**, a grille assembly **204**, and an I/O assembly **206**. The grille assembly **204** may have a similar construction to the one described above with respect to FIG. 1B. As shown in FIG. 2B, the grille assembly **204** may include a grille **208**, a water-resistant member **210** including a scrim layer **212** and a screen layer **214**, and a spring member **216**. However, in the implementation illustrated in FIGS. 2A & 2B, cross-members **218** of the spring member **216** define a notch **220**. The notch **220** is configured to accommodate the geometry of an electro-acoustic transducer **222** (FIG. 2A); i.e., to prevent the spring member **216** from interfering with the electro-acoustic transducer **222**.

In some implementations, the weather-resistant member may consist of a scrim layer without a screen backing layer. Alternatively, the weather-resistant member may consist of a screen layer without a scrim layer. In some cases, the loudspeaker may include a cosmetic material as an alternative to or in addition to the weather-resistant member.

While an implementation has been described in which the spring member is formed of stamped and formed sheet metal, an alternative spring member could be formed of wire mesh (e.g., "chicken wire") that is bend to shape.

In some implementations, the cross-members could extend between sidewalls and substantially perpendicular thereto.

While an implementation has been described in which the spring member has substantially arcuate main body that is biased outwardly, away from the acoustic enclosure, in other implementations the main body of the spring member can be flat or inwardly curved, e.g., to work which flat or inwardly curved grille.

A number of implementations have been described. Nevertheless, it will be understood that additional modifications may be made without departing from the scope of the inventive concepts described herein, and, accordingly, other implementations are within the scope of the following claims.

What is claimed is:

1. A loudspeaker comprising: an acoustic enclosure; an electro-acoustic transducer supported by the acoustic enclosure; a grille covering the electro-acoustic transducer; a weather-resistant member disposed between the acoustic enclosure and the grille; and a spring member disposed between the weather-resistant member and the acoustic enclosure, wherein the spring member is configured to apply a force to the weather-resistant member thereby to hold the weather-resistant member against the grille, wherein the spring member comprises an arcuate main body that extends between a pair of opposing sidewalls.
2. The loudspeaker of claim 1, wherein the weather-resistant member comprises a scrim layer.

3. The loudspeaker of claim 2, wherein the scrim layer is formed of an acoustically transparent sheet form foam material.

4. The loudspeaker of claim 1, wherein the arcuate main body is biased outwardly, away from the acoustic enclosure, such that a concave side of the main body faces toward the acoustic enclosure.

5. The loudspeaker of claim 4, wherein the arcuate main body comprises a plurality of cross-members.

6. The loudspeaker of claim 5, wherein the cross-members extend diagonally relative to the sidewalls.

7. The loudspeaker of claim 5, wherein the cross-members intersect with each other at nodes.

8. The loudspeaker of claim 5, wherein the cross-members are arranged to form a notch to accommodate the geometry of the electro-acoustic transducer.

9. The loudspeaker of claim 2, wherein the weather-resistant member further comprises a screen layer disposed between the spring member and the scrim layer, wherein the spring member is configured to apply a force to the screen layer to hold a front surface of the screen layer against a rear surface of the scrim layer and to hold a front surface of the scrim layer against a rear surface of the grille.

10. The loudspeaker of claim 9, wherein the screen layer comprises an acoustically transparent sheet form material formed of a woven fabric of metal filaments.

11. The loudspeaker of claim 1, wherein the weather-resistant member comprises a screen layer.

12. The loudspeaker of claim 11, wherein the screen layer comprises an acoustically transparent sheet form material formed of a woven fabric of metal filaments.

13. A grille assembly for a loudspeaker, the grille assembly comprising:

- a grille;
- a spring member; and
- a weather-resistant member disposed between the spring member and the grille, wherein the spring member is configured to apply a force between an acoustic enclosure of a loudspeaker and the weather-resistant member to hold a front surface of the weather-resistant member substantially flush against a rear surface of the grille,

wherein the spring member comprises an arcuate main body that extends between a pair of opposing sidewalls.

14. The grille assembly of claim 13, wherein the weather-resistant member comprises a scrim layer.

15. The grille assembly of claim 14, wherein the scrim layer is formed of an acoustically transparent sheet form foam material.

16. The grille assembly of claim 13, wherein the sidewalls terminate at a pair of feet, which are arranged to rest against a surface of the acoustic enclosure of the loudspeaker.

17. The loudspeaker of claim 13, wherein the arcuate main body is biased outwardly, away from the acoustic enclosure, such that a concave side of the main body faces toward the acoustic enclosure.

18. The grille assembly of claim 13, wherein the arcuate main body comprises a plurality of cross-members.

19. The grille assembly of claim 18, wherein the cross-members extend diagonally relative to the sidewalls.

20. The grille assembly of claim 18, wherein the cross-members intersect with each other at nodes.

21. The grille assembly of claim 18, wherein the cross-members are arranged to form a notch to accommodate the geometry of an electro-acoustic transducer of the loudspeaker.

22. The grille assembly of claim 14, wherein the weather-resistant member further comprises a screen layer disposed between the spring member and the scrim layer, wherein the spring member is configured to apply a force to the screen layer to hold a front surface of the screen layer against a rear surface of the scrim layer and to hold a front surface of the scrim layer against a rear surface of the grille.

23. The grille assembly of claim 22, wherein the screen layer comprises an acoustically transparent sheet form material formed of a woven fabric of metal filaments.

24. The grille assembly of claim 13, wherein the weather-resistant member comprises a screen layer.

25. The grille assembly of claim 24, wherein the screen layer comprises an acoustically transparent sheet form material formed of a woven fabric of metal filaments.

* * * * *