



(22) Date de dépôt/Filing Date: 2004/03/10

(41) Mise à la disp. pub./Open to Public Insp.: 2005/09/10

(45) Date de délivrance/Issue Date: 2012/07/10

(51) Cl.Int./Int.Cl. *E04D 13/158* (2006.01)

(72) Inventeurs/Inventors:
BROCHU, GUY, CA;
BROCHU, STEPHANE, CA

(73) Propriétaires/Owners:
BROCHU, GUY, CA;
BROCHU, STEPHANE, CA

(74) Agent: FINCHAM, ERIC

(54) Titre : SUPPORT DE SOFFITE

(54) Title: SOFFIT SUPPORT

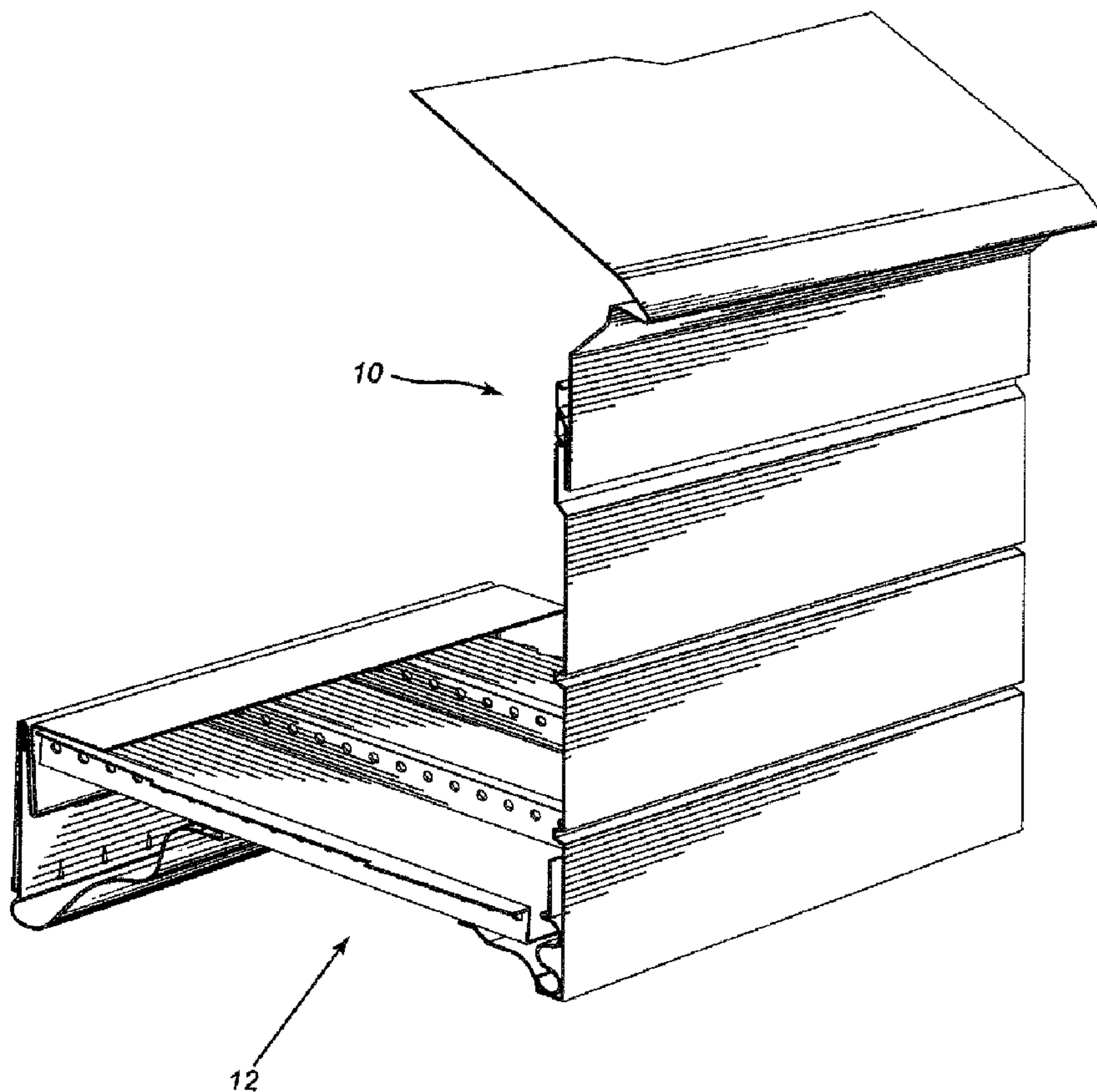

(57) Abrégé/Abstract:

The support structure for a soffit which comprises a first member having a central vertical section with a support element extending outwardly from a lower portion thereof and the retaining structure located proximate an upper end of the central vertical section, a



(57) **Abrégé(suite)/Abstract(continued):**

second member having a central section adapted to lie adjacent the central section of the first member with the second member having engaging means located at a lower portion thereof designed to engage the support element of the first member and the second member having a second portion extending upwardly and outwardly to abut a soffit, the arrangement being such that the second member central section is retained between the retaining structure of the first member and the support element of the first member. This provides an arrangement wherein the soffit is supported without any outwardly visible attaching beams.

ABSTRACT

The support structure for a soffit which comprises a first member having a central vertical section with a support element extending outwardly from a lower portion thereof and the retaining structure located proximate an upper end of the central vertical section, a second member having a central section adapted to lie adjacent the central section of the first member with the second member having engaging means located at a lower portion thereof designed to engage the support element of the first member and the second member having a second portion extending upwardly and outwardly to abut a soffit, the arrangement being such that the second member central section is retained between the retaining structure of the first member and the support element of the first member. This provides an arrangement wherein the soffit is supported without any outwardly visible attaching beams.

SOFFIT SUPPORT

FIELD OF THE INVENTION

The present invention relates to an improved fascia and soffit structure for buildings.

BACKGROUND OF THE INVENTION

The fascia is that part of a building where the roof terminates. Typically, most residences and relatively small commercial or industrial establishments utilize a sloping roof. The roof structure includes a plurality of rafters upon which a solid material such as plywood or the like is placed. Subsequently, a weatherproofing component is applied on top thereof, the weatherproofing component typically being asphalt tiles although metal, shakes, other types of tiles, and composite materials have all been known to be utilised.

At the point where the rafters terminate, a fascia is installed and extends along the ends of the rafters. Typically, the fascia may comprise a wooden member and/or a metal member secured to the rafter ends. Typically, the metal member has a L-shaped configuration which extends along the fascia and inwardly towards the soffit portion of the eaves.

A soffit structure is generally utilized to provide ventilation to the air space under the roof. Typically, the soffit will comprise a piece of metal or plastic having apertures therein to permit the passage of air into the air space. A second outlet such as a roof vent is provided to encourage the flow of air therethrough.

The arrangement of the fascia and soffit has essentially not changed for many years. The fascia will usually comprise a wooden strip nailed along the ends of the rafters and this is then covered by a metal or plastic fascia member. However, it is also known to only use the metal or plastic fascia.

SUMMARY OF THE INVENTION

It is an object of the present invention to provide a support member for a soffit and also to provide an integrated fascia and soffit structure.

According to one aspect of the present invention, there is provided a support structure for a soffit, the support structure comprising a first member having a central vertical section, a support element extending outwardly from a lower portion of the central vertical section, a retaining structure located proximate an upper portion of the central vertical section, a second member having a second member central section adapted to lie adjacent the central section of the first member, the second member having engaging means located at a lower portion of said central section, the engaging means being designed to engage the support element of the first member, the second member having a second portion extending upwardly and outwardly to abut a soffit, the arrangement being such that the second member central section is retained between the retaining structure of the first member and the support element of the first member.

The first member of the soffit support structure is designed to be secured to a substrate and to retain and support the second member which in turn supports the soffit. As such, the first member will have a section which is designed to lie adjacent to a vertical structure such as the building wall and will also have a section which is designed to lie underneath the soffit.

The first member, in order to fulfill its function as a means of securing and retaining the second member, has to ensure that the second member remains securely retained in position, preferably without the use of any fastening members.

To this end, the first member may be secured either through the vertical portion to

an adjacent wall or alternatively along the horizontal portion to the underside of the roof structure. If desired, the first member could be secured to both of the structures. The means for fastening the first member may include all the conventional methods including the use of mechanical fastening members, adhesives, etc.

The second member has a first section which is designed to be secured to and retained by the first member, and a second section which is designed to support the soffit.

The first section is designed to be retained by and secured to the first member and preferably is retained by means of a slight compression thereof. To this end, the first section of the second member has its upper and lower portions engaged by the first member. Conveniently, this is accomplished by engaging means located at a lower portion of the first section and which engaging means seat on the lower support element of the first member while an upper portion is retained within a channel formed at an upper portion of the vertical section of the first member.

BRIEF DESCRIPTION OF THE DRAWINGS

Having thus generally described the invention, reference will be made to the accompanying drawings illustrating an embodiment thereof, in which:

Figure 1 is a perspective view of the support structure for a soffit in conjunction with a fascia system;

Figure 2 is a side sectional view thereof;

Figure 3 is a side sectional view of the first member of the support structure;

Figure 4 is a perspective view thereof;

Figure 5 is a side-sectional view of the second member of the soffit support; and

Figure 6 is a perspective view thereof.

DESCRIPTION OF THE PREFERRED EMBODIMENTS

Referring to the drawings in greater detail and by reference characters thereto, there is illustrated in Figure 1 a fascia support system generally designated by reference numeral 10 and which fascia support system is described in United States Patent Number 7,823,336. Associated with fascia support system 10 is a soffit structure 12 which is shown and described in United States Publication Number 2005/0193671 A1.

The soffit support of the present invention includes a first member generally designated by reference numeral 14. First member 14 has a vertical wall section 16 which, at its upper end, terminates in an upper bight 18. Extending downwardly from upper bight 18 is a second vertical section 20 which likewise terminates in a lower bight 22. As may be seen in Figure 3, a channel 17 is thus formed between sections 16 and 20. Channel 17 has an inwardly tapered configuration.

From lower bight 22, first member 14 has an upwardly extending section 24 which terminates in a horizontal section 26.

As may be best seen in Figure 3, at the lower end of vertical wall section 16, there is provided a flange 28 for reasons which will become apparent hereinbelow.

A second member of the soffit support is generally designated by reference numeral 30 and includes a second member central section 32 having an upper bight 34. As may be best seen in Figure 5, tabs 36 are formed within central section 32 and extend rearwardly thereof.

At the lower end of central section 32, there is provided an arcuate section generally

designated by reference numeral 38 and which in turn continues as a diagonally extending side wall generally designated by reference numeral 40. Side wall 40 terminates in a horizontal section 42 which in turn continues as an inwardly turned horizontal section 46 through bight 44.

In use, first member 14 is suitably secured to a structure either by a means of vertical section 16 or horizontal section 26 by suitable means (not shown). Subsequently, central section 32 of second member 30 is inserted in channel 17 with tabs 36 resting on flange 28. Naturally, flange 28 could be angled upwardly to better engage tabs 36. The sizing is such that the top of central section 32 is frictionally engaged within channel 17 and securely held thereby. A downwardly extending pressure is put on tabs 36.

In so doing, soffit 12 is then supported by the horizontal sections 42 and 46.

It will be understood that the above described embodiment is for purposes of illustration only and that changes and modifications may be made thereto without departing from spirit and scope of the invention.

1. A fascia and soffit system comprising a fascia component, a soffit component, and a soffit support structure;

said fascia component comprising a first member and a second member, said first member having an upper section designed for securement to an upper surface of a roof member, a drip edge formed at an extremity of said upper section and extending outwardly away from said roof, a transition section extending inwardly and downwardly from said first section, and a lower section extending vertically downwardly from said transition section, said lower section having first cooperative locking means on an inner side thereof;

said second member comprising a fascia member having second cooperative locking means extending outwardly from an upper portion of said fascia member;

an inwardly extending flange arrangement at the bottom end of said generally planar portion designed to abut an adjoining soffit;

said soffit support structure comprising:

a first member having a central vertical section, a support element extending outwardly from a lower portion of said central vertical section, a retaining structure located proximate an upper portion of said central vertical section;

a second member having a second member central section adapted to lie adjacent said central vertical section of said first member, said second member having engaging means located at a lower portion of said central section, said engaging means being designed to engage said support element of said first member, said second member having a second portion extending upwardly and outwardly to abut a soffit;

the arrangement being such that said second member central section is retained between said retaining structure of said first member and said support element of said first member.

2. The system of Claim 1 wherein said support element comprises an outwardly directed flange, said vertical section of said second member having a plurality of projections extending outwardly towards said first member, the arrangement being such that said projections rest on said outwardly directed flange.
3. The system of Claim 1 wherein said first member and said second member are formed from metallic sheet material.
4. The system of Claim 3 wherein said metallic sheet material is selected from the group consisting of aluminum and aluminum alloys.
5. The system of Claim 1 wherein said retaining structure of said first member has a U-shaped channel sized to frictionally receive and engage said second member central section of said second member.
6. A fascia and soffit system comprising a fascia component, a soffit component, and a soffit support structure;
said fascia component comprising a first member and a second member, said first member having an upper section designed for securement to an upper surface of a roof member, a drip edge formed at an extremity of said upper section and extending outwardly away from said roof, a transition section extending inwardly and downwardly from said first section, and a lower section extending vertically downwardly from said transition section, said lower section having first cooperative locking means on an inner side thereof;
said second member comprising a fascia member having second cooperative locking means extending outwardly from an upper portion of said fascia member;
said soffit support structure comprising:
an inwardly extending flange arrangement at the bottom end of said generally planar portion designed to abut an adjoining soffit;

a tensioning member for mounting to a fascia, said tensioning member being designed to abut and bias said inwardly extending flange arrangement;

said soffit support structure comprising:

a first member having a central vertical section, a support element extending outwardly from a lower portion of said central vertical section, a retaining structure located proximate an upper portion of said central vertical section;

a second member having a second member central section adapted to lie adjacent said central vertical section of said first member, said second member having engaging means located at a lower portion of said central section, said engaging means being designed to engage said support element of said first member, said second member having a second portion extending upwardly and outwardly to abut a soffit;

the arrangement being such that said second member central section is retained between said retaining structure of said first member and said support element of said first member.

7. The system of Claim 6 wherein said support element comprises an outwardly directed flange, said vertical section of said second member having a plurality of projections extending outwardly towards said first member, the arrangement being such that said projections rest on said outwardly directed flange.

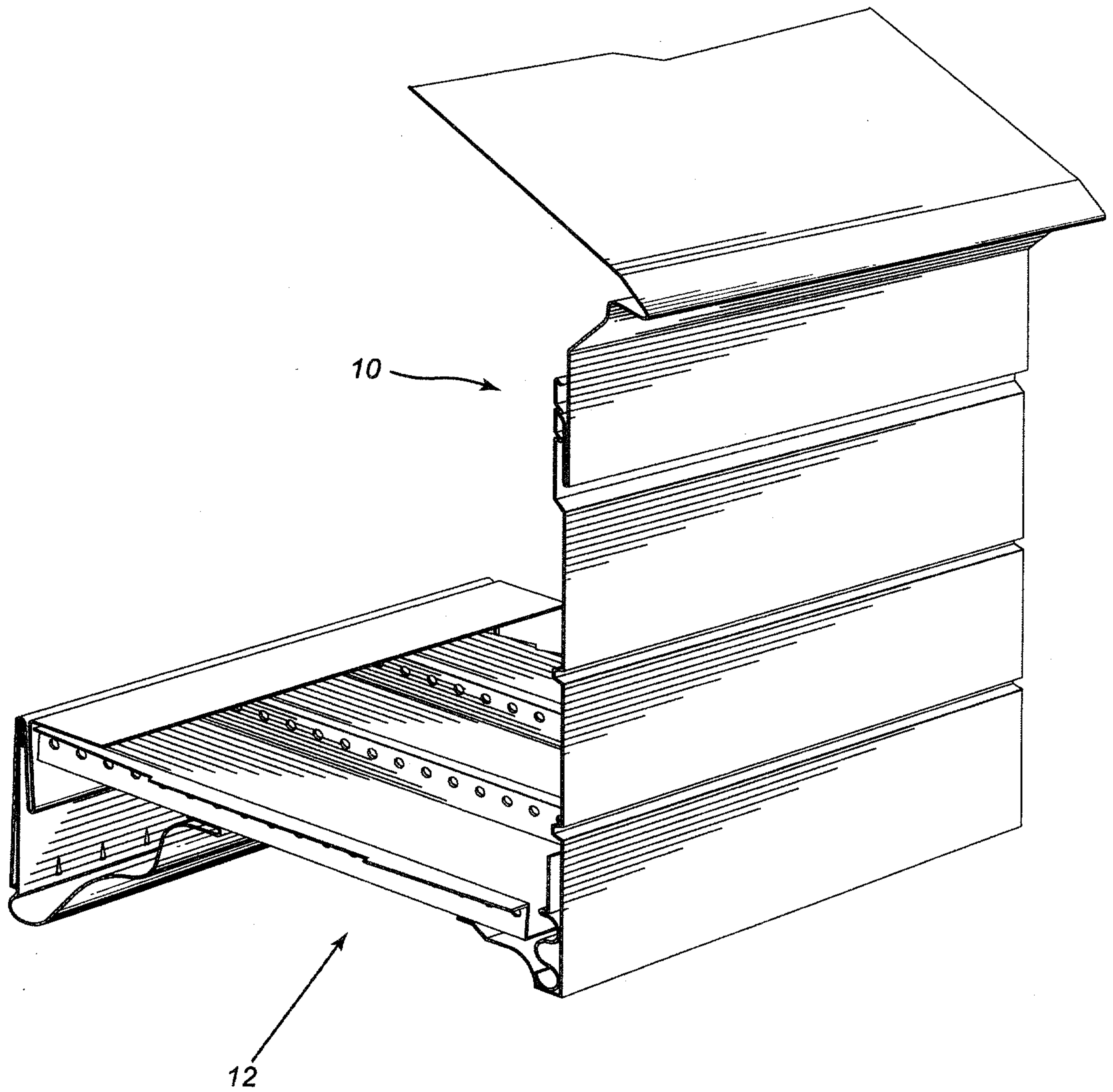

Fig-1

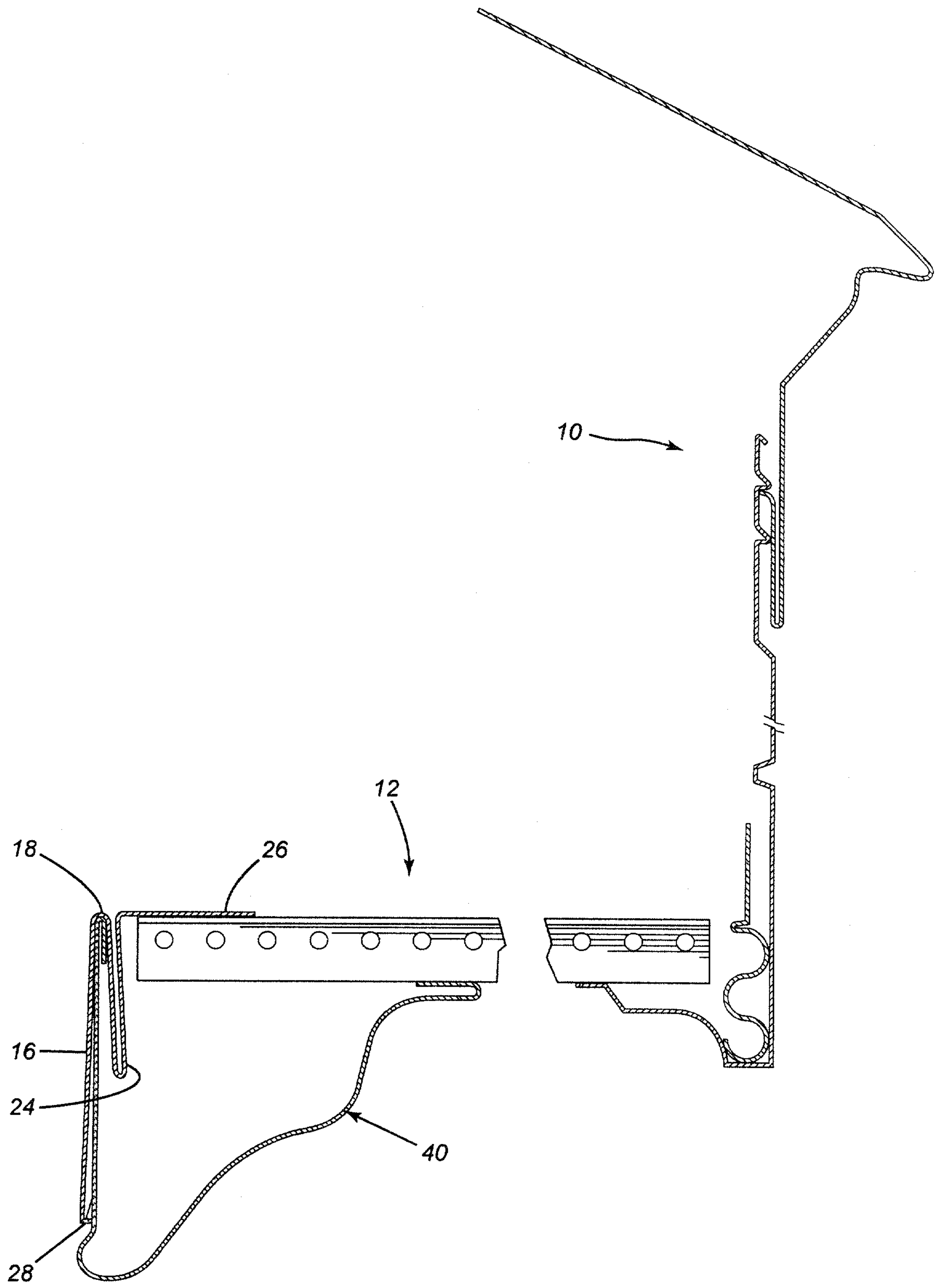

Fig-2

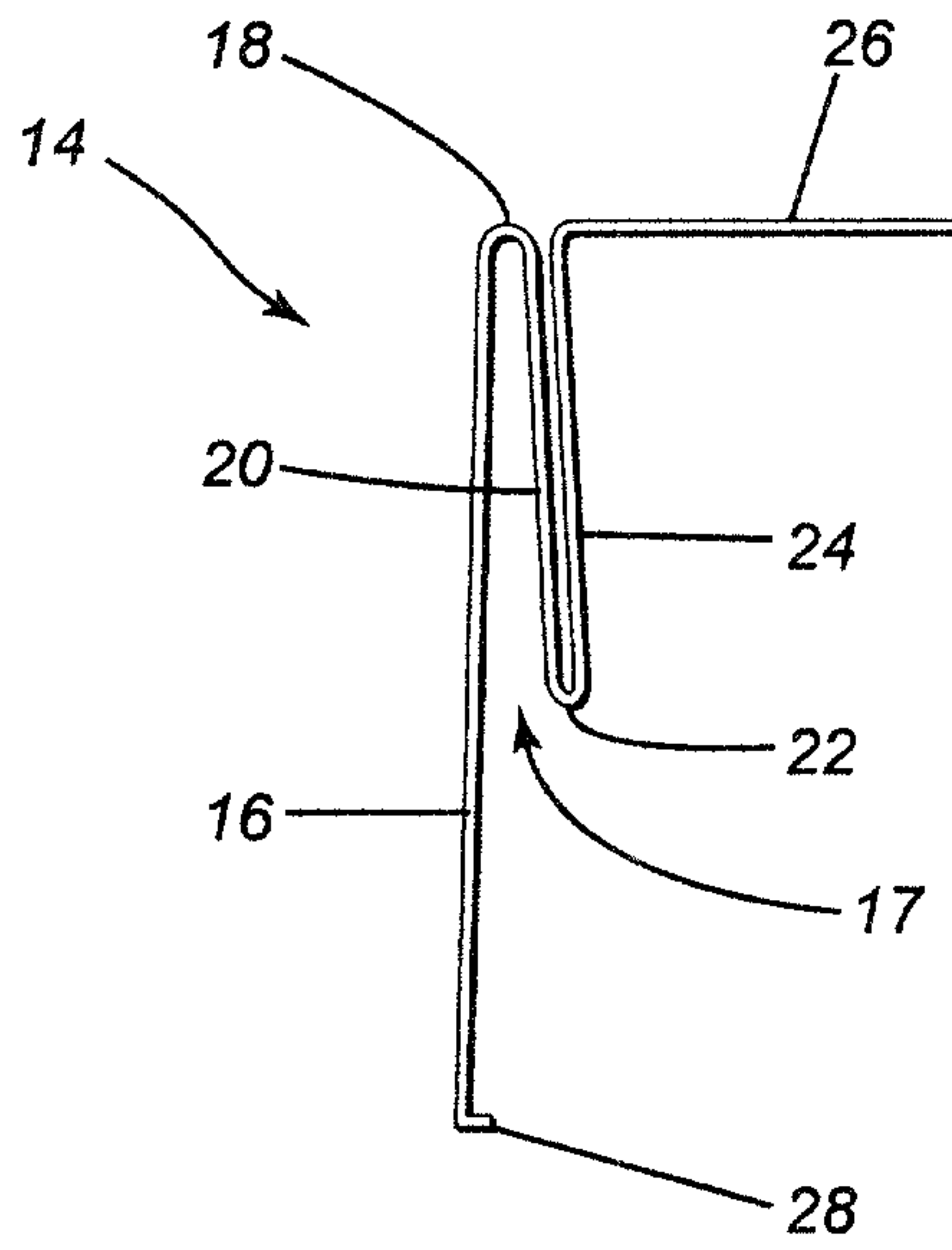

Fig-3

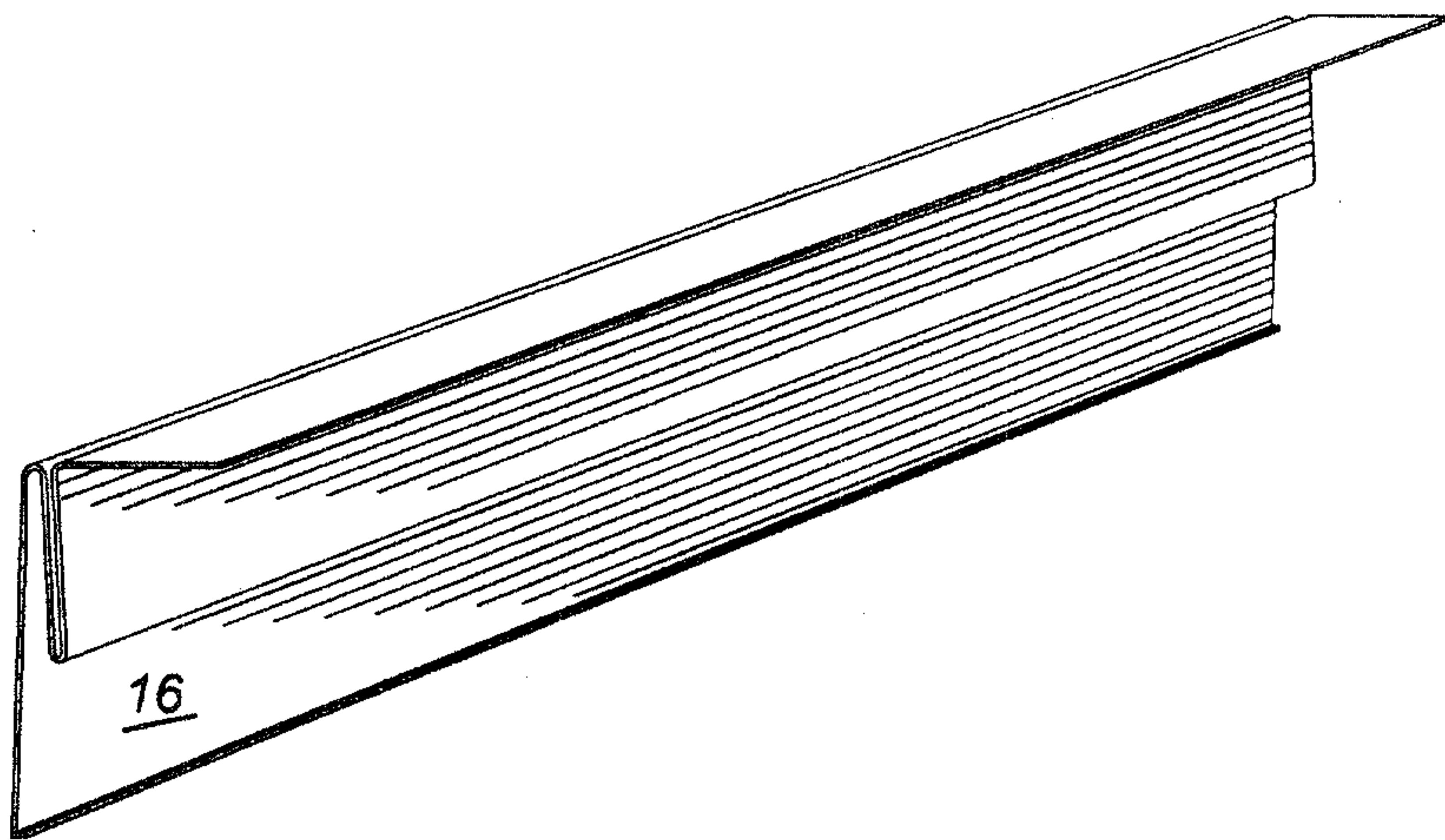

Fig-4

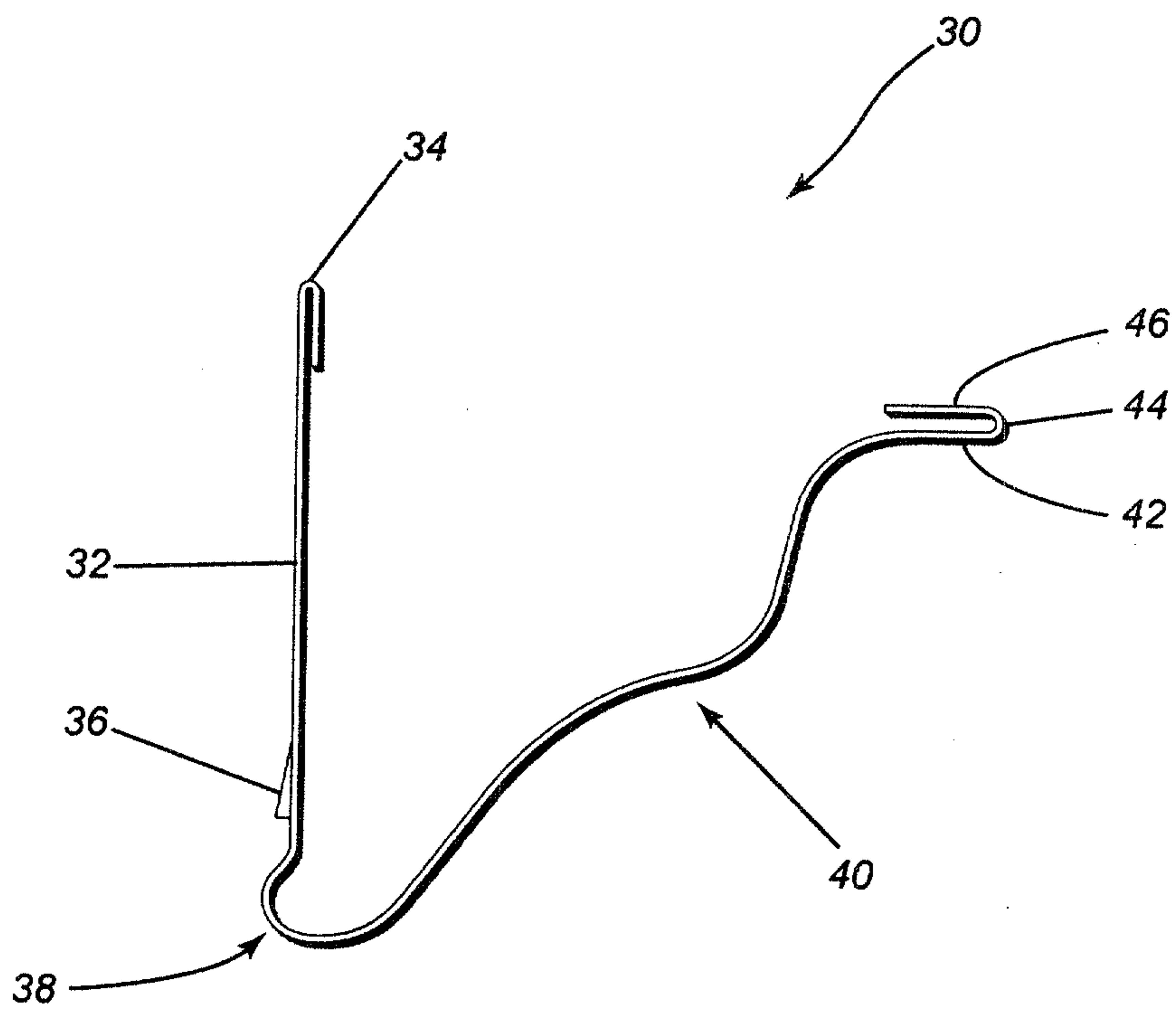

Fig-5

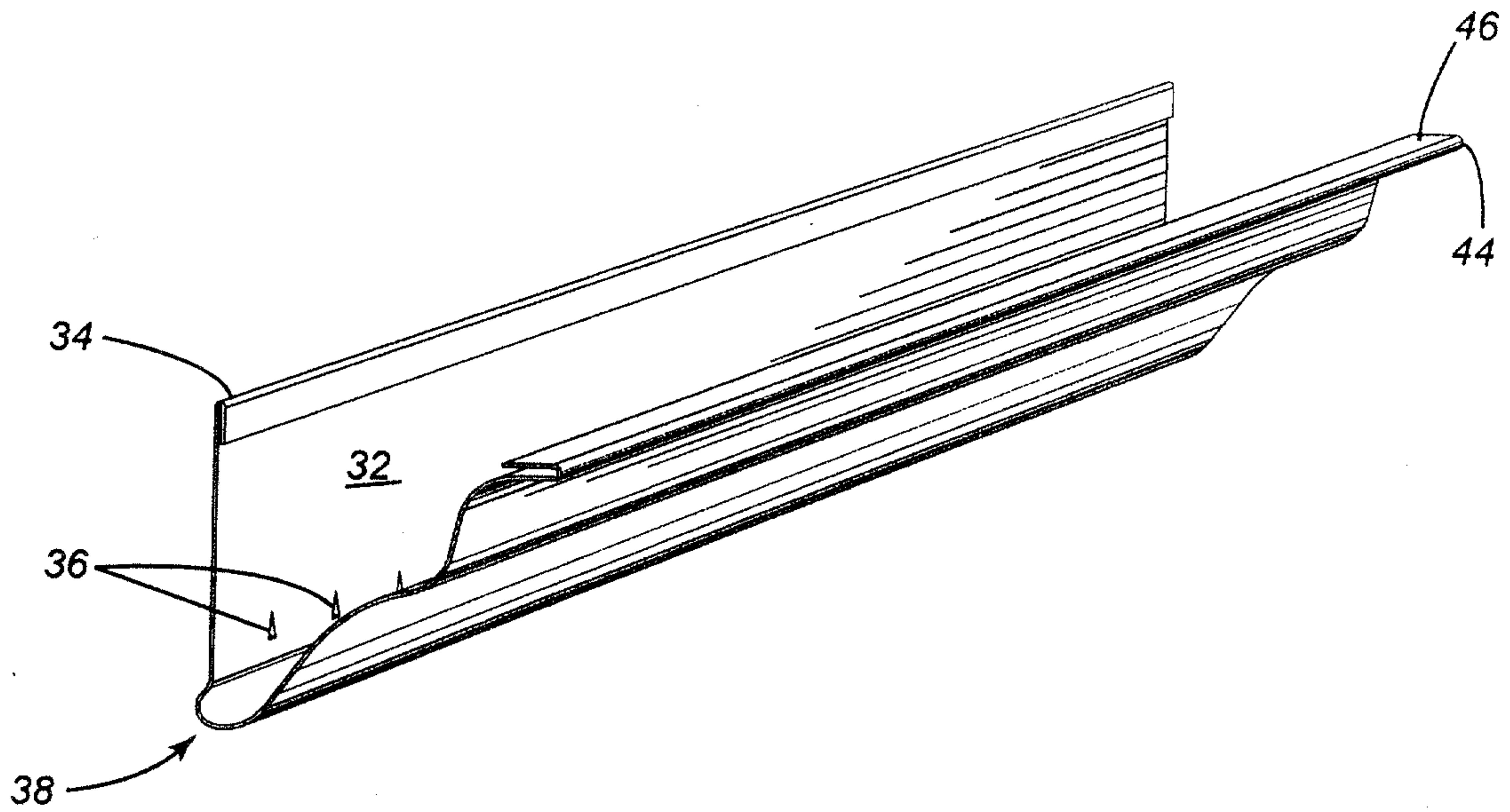

Fig-6

