



(86) Date de dépôt PCT/PCT Filing Date: 2011/03/15
 (87) Date publication PCT/PCT Publication Date: 2011/09/22
 (85) Entrée phase nationale/National Entry: 2012/10/12
 (86) N° demande PCT/PCT Application No.: US 2011/028541
 (87) N° publication PCT/PCT Publication No.: 2011/116005
 (30) Priorité/Priority: 2010/03/15 (US61/314,137)

(51) Cl.Int./Int.Cl. *E03D 11/00* (2006.01)
 (71) Demandeur/Applicant:
 ROSS TECHNOLOGY CORPORATION, US
 (72) Inventeurs/Inventors:
 BLEECHER, DOUGLAS, US;
 HARSH, PHILIP, US;
 HURLEY, MICHAEL, US;
 JONES, ANDREW K., US;
 CHAN LOR, BOON, US;
 SIKKA, VINOD K., US
 (74) Agent: BERESKIN & PARR LLP/S.E.N.C.R.L.,S.R.L.

(54) Titre : PISTON ET PROCEDES DE PRODUCTION DE SURFACES HYDROPHOBES
 (54) Title: PLUNGER AND METHODS OF PRODUCING HYDROPHOBIC SURFACES

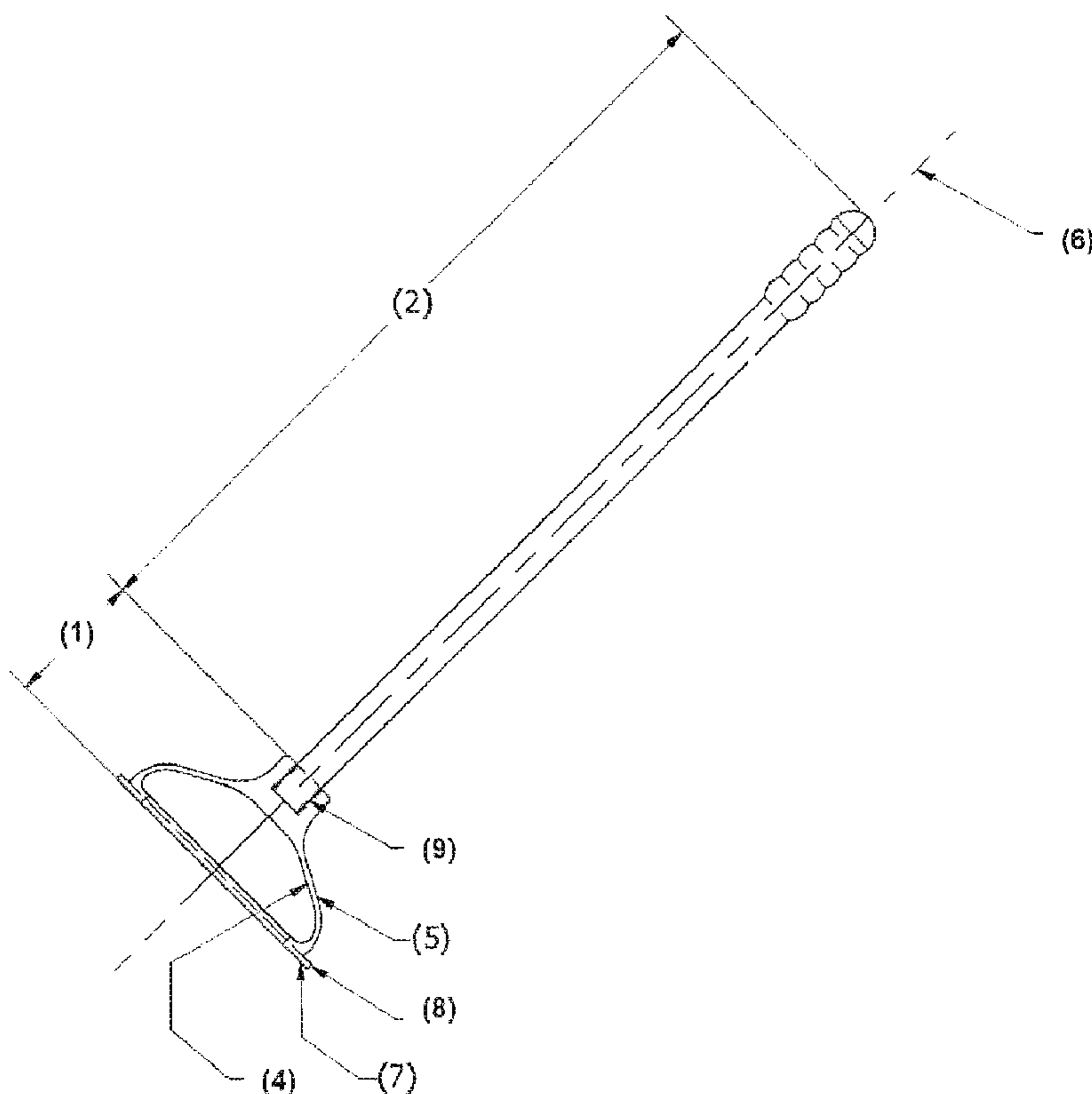

Figure 1

(57) Abrégé/Abstract:

Highly durable hydrophobic and/or oleophobic coatings and methods and compositions for their production are described herein. Also described herein is a plunger having a hydrophobic surface prepared using the coating compositions described herein.

(12) INTERNATIONAL APPLICATION PUBLISHED UNDER THE PATENT COOPERATION TREATY (PCT)

(19) World Intellectual Property Organization
International Bureau(43) International Publication Date
22 September 2011 (22.09.2011)(10) International Publication Number
WO 2011/116005 A1(51) International Patent Classification:
E03D 11/00 (2006.01)(21) International Application Number:
PCT/US2011/028541(22) International Filing Date:
15 March 2011 (15.03.2011)

(25) Filing Language: English

(26) Publication Language: English

(30) Priority Data:
61/314,137 15 March 2010 (15.03.2010) US(71) Applicant (for all designated States except US): **ROSS TECHNOLOGY CORPORATION** [US/US]; 104 N. Maple Avenue, P.O. Box 646, Leola, PA 17540-0646 (US).

(72) Inventors; and

(75) Inventors/Applicants (for US only): **BLEECHER, Douglas** [US/US]; 622 Courthouse Circle, Lititz, PA 17543(US). **HARSH, Philip** [US/US]; 538 Bentley Ridge Boulevard, Lancaster, PA 17602 (US). **HURLEY, Michael** [US/US]; 1317 Newton Road, Lancaster, PA 17603 (US). **JONES, Andrew, K.** [US/US]; 124 Roundtop Drive, Lancaster, PA 17601 (US). **CHAN LOR, Boon** [US/US]; 117 South 4th Street, Denver, Pennsylvania 17517 (US). **SIKKA, Vinod, K.** [US/US]; 115 Dansworth Lane, Oak Ridge, Tennessee 37830 (US).(74) Agent: **SANDERCOCK, Colin, G.**; Perkins Coie LLP, 700 Thirteenth Street, N.W., Washington, DC 20005 (US).

(81) Designated States (unless otherwise indicated, for every kind of national protection available): AE, AG, AL, AM, AO, AT, AU, AZ, BA, BB, BG, BH, BR, BW, BY, BZ, CA, CH, CL, CN, CO, CR, CU, CZ, DE, DK, DM, DO, DZ, EC, EE, EG, ES, FI, GB, GD, GE, GH, GM, GT, HN, HR, HU, ID, IL, IN, IS, JP, KE, KG, KM, KN, KP, KR, KZ, LA, LC, LK, LR, LS, LT, LU, LY, MA, MD, ME, MG, MK, MN, MW, MX, MY, MZ, NA, NG, NI, NO, NZ, OM, PE, PG, PH, PL, PT, RO, RS, RU, SC, SD,

[Continued on next page]

(54) Title: PLUNGER AND METHODS OF PRODUCING HYDROPHOBIC SURFACES

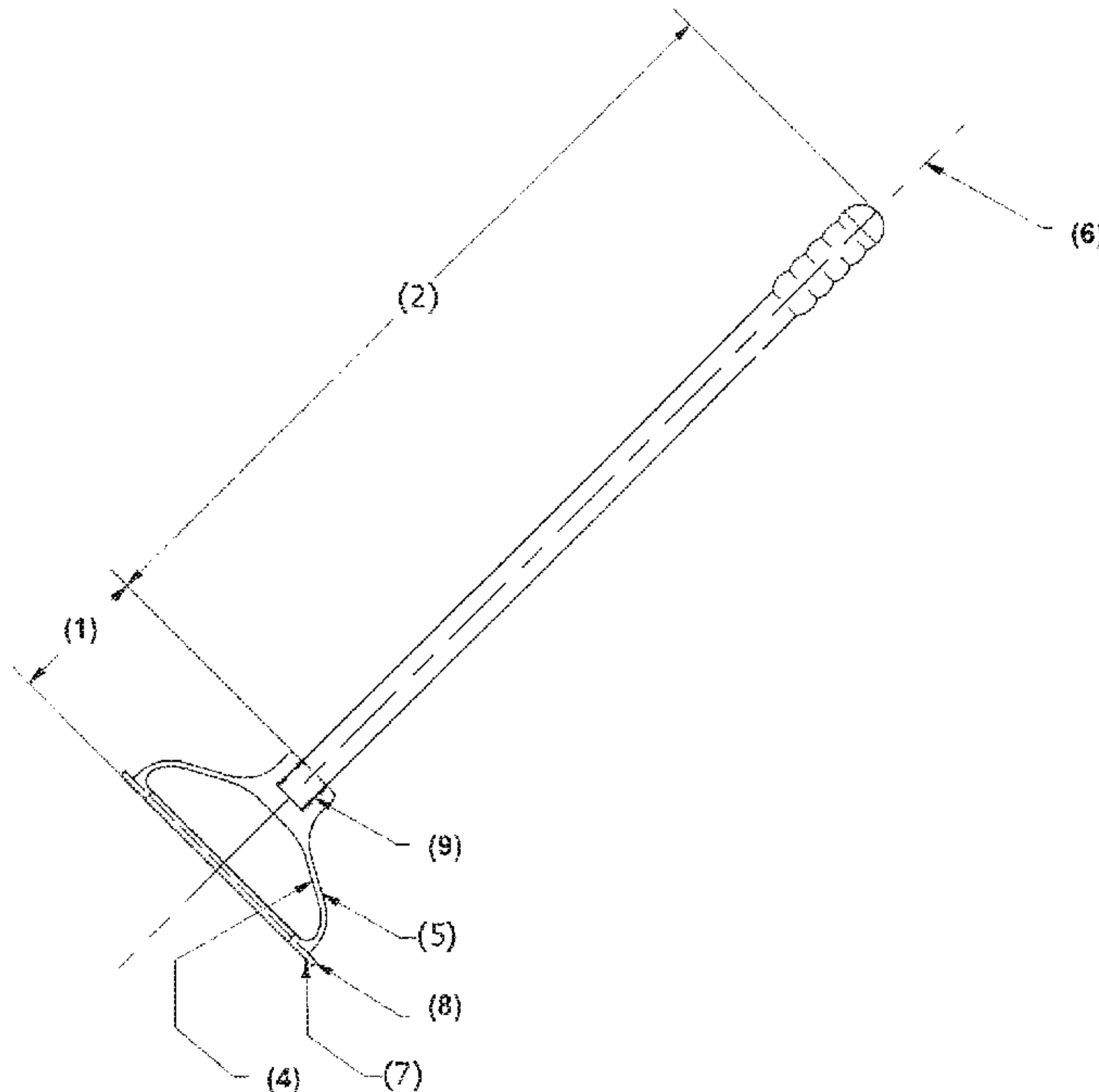

Figure 1

[Continued on next page]

WO 2011/116005 A1

SE, SG, SK, SL, SM, ST, SV, SY, TH, TJ, TM, TN, TR,
TT, TZ, UA, UG, US, UZ, VC, VN, ZA, ZM, ZW.

(84) Designated States (*unless otherwise indicated, for every kind of regional protection available*): ARIPO (BW, GH, GM, KE, LR, LS, MW, MZ, NA, SD, SL, SZ, TZ, UG, ZM, ZW), Eurasian (AM, AZ, BY, KG, KZ, MD, RU, TJ, TM), European (AL, AT, BE, BG, CH, CY, CZ, DE, DK,

EE, ES, FI, FR, GB, GR, HR, HU, IE, IS, IT, LT, LU, LV, MC, MK, MT, NL, NO, PL, PT, RO, RS, SE, SI, SK, SM, TR), OAPI (BF, BJ, CF, CG, CI, CM, GA, GN, GQ, GW, ML, MR, NE, SN, TD, TG).

Published:

— *with international search report (Art. 21(3))*

(57) Abstract: Highly durable hydrophobic and/or oleophobic coatings and methods and compositions for their production are described herein. Also described herein is a plunger having a hydrophobic surface prepared using the coating compositions described herein.

**PLUNGER AND METHODS OF PRODUCING
HYDROPHOBIC SURFACES**

BACKGROUND

Priority Data & Incorporation By Reference

[0001] This international application claims the benefit of priority to U.S. Provisional Patent Application No. 61/314,137, filed March 15, 2010, entitled "**Plunger and Methods of Producing Hydrophobic Surfaces**" which is incorporated by reference in its entirety.

[0002] A plunger is the most common household article used to clear clogged plumbing fixtures such as drains, toilets, and sinks. As seen in Fig. 1, the plunger generally consists of two parts: (1) a cup and (2) a handle. With a slightly modified cup, which has a skirt (3) protruding from the cup (Fig. 2), the plunger is used for industrial applications such as in hotels. The plunger cup typically consists of rubber or a flexible polyvinyl chloride (PVC) material. PVC is sometimes prepared as a composite with fillers such as thermoplastic rubber (TPR), and up to 35% of the fillers is added to the PVC for optimizing flexibility and hardness of the plunger cup. The handle is typically wood or solid plastic, but other materials such as clear acrylic are used.

[0003] Regardless of the materials used to construct a plunger or the exact form of the cup, plungers operate by making a seal with the plumbing fixture's surfaces after which the application of pressure on the flexible cup through the handle creates a pressure that clears clogs. The number of times pressure must be applied to the handle to create a plunging action depends on the severity of the clog.

[0004] After use, the plunger (cup and handle) typically are covered in materials originally destined for the sewer, such as toilet water and/or other materials such as fecal matter. That water and other materials tend to drip onto the floor when the plunger is removed from the toilet and contaminate any surface it comes into contact with. Not only is the water dripping on the floor highly undesirable with regard to the cleanliness of the bathroom and damage to the floor's surface but it also creates sites for bacterial growth.

BRIEF DESCRIPTION OF THE DRAWINGS

[0005] Fig. 1 shows three views of a typical household drain plunger showing the cup (1) with an optional lip (8) and handle (2).

[0006] Fig. 2 shows three views of a typical industrial (heavy duty) plunger showing a handle and a cup with an optional lip (8) and skirt (3) protruding from the lower edge of the cup.

[0007] Fig. 3 shows an embodiment of a plunger with a hydrophobic (superhydrophobic) coating applied to the cup and a portion (about one-half of the length) of the handle.

[0008] Fig. 4 shows another embodiment of a plunger with a hydrophobic (superhydrophobic) coating applied to the cup.

[0009] Fig. 5 shows another embodiment of an industrial plunger with a hydrophobic (superhydrophobic) coating applied to the cup and a portion of the handle.

DESCRIPTION OF EMBODIMENTS OF THE DISCLOSURE

[00010] Embodiments of this disclosure, which are described herein, provide for a plunger coated in whole or in part with a hydrophobic or superhydrophobic coating that can be used to clear plumbing while advantageously resisting becoming wet and fouled with materials intended for disposal via the drain. The plunger resists wetting and fouling even after dozens or even hundreds of uses, which can be measured by individual compressions of the plunger cup via pressure applied to the handle. In some embodiments, less than about 0.2, about 0.5, about 1, about 2, about 3, or about 4 grams of water remain bound by adhesion to the surface of the plunger after immersion in water at about 20°C, even after the plunger cup has been compressed more than about 300 times by applying force to the handle.

[00011] Embodiments of the plungers described herein that resist wetting and fouling by materials intended for the sewer can provide one or more of a variety of advantages. For example, they can be removed from plumbing fixtures after use with little or no dripping of materials onto the floor and other nearby objects, thus keeping floors and nearby surfaces dry and clean. Embodiments of the plungers described herein also reduce or eliminate the odor associated with used plungers. In addition, bacterial (microbial) growth is less likely to occur on the hydrophobic coatings described herein, whether applied to plungers or other objects, as there will be a limited amount of accumulated water and/or other materials to support growth. Bacterial (microbial) growth can be further suppressed by incorporating a number of different antibacterial and/or antifungal agents into the coatings described herein including, but not limited to, zinc pyrithione, zinc di(lower alkyl)dithiocarbamate (*e.g.*, zinc dimethyldithiocarbamate) and silver (*e.g.*, colloidal silver or silver nanoparticles typically in the range of 1-50 ppm or 10-30 ppm).

[00012] In some embodiments, the coatings applied to all or a part of the plungers described herein will not only be hydrophobic, but also oleophobic. Plungers that are oleophobic in addition to being hydrophobic will further resist wetting and contamination by materials, including fecal matter, that are intended for the sewer. Such plungers will further limit the growth of bacteria by limiting the amount of material present to support its growth.

[00013] Embodiments of the plungers described herein are thus suitable for use in clearing plumbing including clogged toilets, sinks and drain pipes connected to toilets and sinks, including

embodiments that are adapted for industrial use. The shape of the cup (oval, circular etc.) may be made in a variety of widths adapted to clearing specific types of plumbing fixtures. In addition, the use of one or more rubbers to prepare cups having suitable stiffness and resilience can permit embodiments of the plungers described herein to adapt its contours to the surface of plumbing fixtures.

1.0 DEFINITIONS

[00014] For the purposes of this disclosure a hydrophobic coating is one that results in a water droplet forming a surface contact angle exceeding about 90° and less than about 150° at room temperature (about 18 to about 23°C). Similarly, for the purposes of this disclosure a superhydrophobic coating is one that results in a water droplet forming a surface contact angle exceeding about 150° but less than the theoretical maximum contact angle of about 180° at room temperature. The term hydrophobic includes superhydrophobic, and may be limited to superhydrophobic, unless stated otherwise.

[00015] For the purposes of this disclosure an oleophobic material or surface is one that results in a droplet of light mineral oil forming a surface contact angle exceeding about 25° and less than the theoretical maximum contact angle of about 180° at room temperature.

[00016] Durability, unless stated otherwise, refers to the resistance to loss of hydrophobic properties due to mechanical abrasion or flexing.

[00017] Moiety or moieties, for the purpose of this disclosure, refers to a chemical group (*e.g.*, alkyl group, fluoroalkyl group, haloalkyl group) bound directly or indirectly (*e.g.*, covalently) to another part of a molecule or another substance or material (*e.g.*, a first or second particle). A moiety also includes chemical components of materials that are associated with a material (*e.g.*, components of first or second particles) that are not covalently bound to the particles (*e.g.*, siloxanes or silazanes associated with first or second particles).

[00018] Alkyl as used herein denotes a linear or branched alkyl radical. Alkyl groups may be independently selected from C₁ to C₂₀ alkyl, C₂ to C₂₀ alkyl, C₄ to C₂₀ alkyl, C₆ to C₁₈ alkyl, C₆ to C₁₆ alkyl, or C₆ to C₂₀ alkyl. Unless otherwise indicated, alkyl does not include cycloalkyl. Cycloalkyl groups may be independently selected from: C₄ to C₂₀ alkyl comprising one or two C₄ to C₈ cycloalkyl functionalities; C₄ to C₂₀ alkyl comprising one or two C₄ to C₈ cycloalkyl functionalities; C₆ to C₂₀ alkyl comprising one or two C₄ to C₈ cycloalkyl functionalities; C₆ to C₁₈ alkyl comprising one or two C₄ to C₈ cycloalkyl functionalities; and C₆ to C₁₆ alkyl comprising one or two C₄ to C₈ cycloalkyl functionalities. One or more hydrogen atoms of the alkyl groups may be replaced by fluorine atoms to form fluoroalkyl groups..

[00019] Lower alkyl as used herein denotes a C₁ to C₆ alkyl group.

[00020] Haloalkyl as used herein denotes an alkyl group in which some or all of the hydrogen atoms present in an alkyl group have been replaced by halogen atoms. Halogen atoms may be limited to chlorine or fluorine atoms in haloalkyl groups.

[00021] Fluoroalkyl as used herein denotes an alkyl group in which some or all of the hydrogen atoms present in an alkyl group have been replaced by fluorine atoms.

[00022] Perfluoroalkyl as used herein denotes an alkyl group in which fluorine atoms have been substituted for each hydrogen atom present in the alkyl group.

[00023] For the purpose of this disclosure, when content is indicated as being present on a "weight basis" the content is measured as the percentage of the weight of components indicated, relative to the total weight of the binder system. When a liquid component such as a commercial binder product is used, the weight of the liquid component is used to calculate the weight basis, without regard to the relative amounts of solute and solvent that might be present in the commercial product. Thus, for example, when Polane is used as a binder, the weight basis is calculated using the weight of the Polane prepared as instructed by the manufacturer, without regard to the proportions of polyurethane solute and organic solvents. Optional solvents that are separately added to a composition merely to, for example, dilute the composition to a thickness suitable for spraying, are not included in the calculation of content on a weight basis.

[00024] Water-based as used herein to refer to binders refers to liquid compositions that comprise water or which can be diluted with water (*e.g.*, to reduce viscosity). Water-based binder compositions include solutions, dispersion, suspensions, emulsion gels and the like.

[00025] The term metalloid includes the elements B, Si, Sb, Te and Ge. Oxides of metalloids or metalloid oxides include, but are not limited to, oxides of B, Si, Sb, Te, and Ge, such as SiO₂.

2.0 PLUNGER CUPS

[00026] Referring now to Figure 1, embodiments of plunger cups disclosed herein may take many forms. Generally, the cups are shaped to have a concave inner surface (4) and a convex outer surface (5) to which the handle is attached at a point that can be reinforced or built conform to an end of the handle (9). The inner surface and outer surface meet at a rim (7) that may have an optional lip attached (8). The point where the handle is attached may be reinforced to provide an adequate strength to the joint and to spread the force applied to the cup from the handle. The shape at the point where the handle attaches to the outer surface of the cup may thus depart from a convex shape. A cross section through the cup parallel to the rim and generally perpendicular to the long axis of the handle (6) is generally circular, oval, elliptical, or oblate. In addition to the cups shown in the accompanying drawings, some examples of suitable cup shapes can be observed in U.S. Patent Nos. 4,622,702 and

4,768,237, the disclosures of which are incorporated herein by reference in terms of their disclosures of plunger-cup shapes.

[00027] Referring to Figure 2, in some embodiments, particularly industrial embodiments, the cup may be fitted with a "skirt" (3), which assists in conforming the plunger to the shape of the plumbing fixtures. The skirts are generally cylindrical sections of material that attach to, or just inside of, the rim of the cup. The skirt may narrow slightly as it extends away from the cup. Skirts, when present, are generally made from the same material as the cup, and in one piece with the cup, although they also can be made of a different material.

[00028] In embodiments described herein, plunger cups may be made from a resilient material that is resistant to water. In some embodiments the plunger consists of rubber (natural or synthetic) or a flexible polyvinyl chloride (PVC) material. Where PVC is employed, may be prepared as a composite with fillers such as thermoplastic rubber (TPR), which may be added in an amounts, *e.g.*, up to 35% (by weight) or more, to impart desirable properties such as increasing the flexibility of the PVC while providing appropriate hardness and resilience. In other embodiments, the cup may be made from a rubber selected from the group consisting of: nitrile rubber, acrylonitrile-butadiene (NBR), natural rubber, butadiene-type rubber, styrene-butadiene rubber, chloroprene, ethylene propylene diene modified rubber (EPDM), polyurethane rubber, butyl rubber, neoprene, isoprene, polyisoprene, halobutyl rubber, fluoroelastomers, epichlorohydrin rubber, polyacrylate rubber, chlorinated polyethylene rubber, hydrogenated SBR, hydrogenated NBR, carboxylated NBR, silicone rubber, or mixtures, copolymers or terpolymers thereof.

3.0 HANDLES

[00029] Handles of plungers are generally attached to the outer surface of the cup at a point where the cup can be effectively compressed to provide pressure to water and material clogging a plumbing fixture. Where the plungers are circular in cross section the handle is typically attached to the outer surface at a point that is approximately equidistant from the rim in all direction.

[00030] Handles for use with plungers can be made of any suitable rigid material including, but not limited to, wood, plastic, and metal. In some embodiments, the handles can be made of clear plastic such as acrylic. In some embodiments, the handles may be hollow and fluid connection with the inside of the cup on one end, and at the other end connected to a source of water to supply pressure, as in U.S. Patent No. 4,768,237, the disclosure of which is incorporated herein by reference in terms of the use of a hollow handle and a fluid connection. The handle also may be provided with a hydrophobic coating as described herein.

4.0 COATINGS

[00031] Coatings applied to the surfaces of the plungers described herein may be any coating that provides a hydrophobic coating that is sufficiently flexible to endure the repeated bending and flexing that the plunger cup will be exposed to during use without substantial loss of hydrophobicity

[00032] In some embodiments, the hydrophobic coatings applied to the plungers, and optionally to the handles, comprise: i) a binder; ii) first particles having a size of about 30 μm to about 225 μm ; and iii) second particles having a size of about 1 nanometer (nm) to about 25 μm comprising one or more independently selected hydrophobic or oleophobic moieties.

[00033] In other embodiments, the hydrophobic coatings applied to the plungers comprise a base coat comprised of said binder and said first particles applied to said cup, and optionally applied to said handle, and a top coat comprised of second particles applied to the base coat after it has been applied to a surface (*e.g.*, a surface of the plunger such as the cup or handle).

4.1 Binders

[00034] Binders used to prepare hydrophobic coatings may have a variety of compositions. One consideration in choosing a suitable binder is the compatibility between the surface to be coated and any solvent(s) used to apply the binder. Virtually any binder may be employed that is capable of adhering to the surface of the plunger while retaining sufficient flexibility that it does not appreciably chip, crack, or peel away from the plunger cup when subjected to repeated flexing due to pressure applied to the plunger handle to the point that the hydrophobic nature of the coating is substantially reduced (*i.e.* the coating hydrophobicity or ability to shed water is not substantially reduced by more than, 5%, 10%, 15%, 20% or 25% (*e.g.*, where a 100 mg of water might adhere to a plunger before being subject to 100 depressions by applying pressure to the handle, the plunger will not retain more than 105, 110, 125, 120, or 125 mg of water adhering to its surface). In some embodiments, the binders employed are hydrophobic in the absence of any added first or second particles, which can be advantageous in the preparation of hydrophobic and/or oleophobic coatings.

[00035] In some embodiments, the binders may be selected from lacquers, polyurethanes (including water based polyurethanes), fluoropolymers, or epoxies. In other embodiments the binders may be selected from lacquers, polyurethanes, or fluoropolymers. Binders may be hydrophilic, hydrophobic, or hydrophobic and oleophobic in the absence of the first and second particles described herein that alters the durability, hydrophobic and oleophobic properties of the binder.

[00036] Where the binders employed are hydrophilic, the coating, including first and second particles, can be given an application of a silanizing agent after it has been applied to the plunger.

[00037] Hydrophobic coatings applied to the surfaces, such as the surfaces of the plungers described herein, may be formed with binders having a broad range of thicknesses. In some embodiments the coatings will have a thickness in a range selected from about 10 μm to about 225 μm . Within this broad range are embodiments employing coatings of thicknesses that range from about 10 μm to about 25 μm , from about 25 μm to about 50 μm , from about 50 μm to about 75 μm , from about 75 μm to about 100 μm , from about 100 μm to about 125 μm , from about 125 μm to about 150 μm , from about 150 μm to about 175 μm , from about 175 μm to about 200 μm , from about 200 μm to about 225 μm , from about 15 μm to about 200 μm ; from about 20 μm to about 150 μm ; from about 30 μm to about 175 μm ; and from about 50 μm to about 200 μm .

4.1.1 Lacquer Binders

[00038] Embodiments of the plunger described herein may employ lacquer binders. Lacquers may be used on a variety of surfaces that may be employed to make plungers and/or plunger handles, and are particularly useful in forming coatings on plastics, woods and metals, including, but not limited to, metals (steel, stainless steel, and aluminum), plastics and rubbers. Lacquer binders typically are polymeric materials that are suspended or dissolved in carrier solvents and which dry to a hard finish, at least in part, by evaporation of the carrier solvents used to apply them. The polymeric binders present in lacquers include, but are not limited to, nitrocellulose and acrylic lacquers; each of which are suitable for use in preparing hydrophobic coatings.

[00039] In embodiments of plungers herein, hydrophilic lacquers may be employed as binders; particularly where the coating will be given an application of a silanizing agent after it has been applied to the substrate. In other embodiments, lacquers that are hydrophobic in the absence of first or second particles described below may be employed to prepare the coatings described herein.

[00040] In addition to the polymeric materials and solvents present in lacquers, a variety of other materials that enhance the properties of lacquers also may be present to impart one or more desirable properties. For example, such materials can provide not only color but also increased adhesion between the lacquer and the surface of the plunger upon which it is applied (*i.e.* the cup or handle).

[00041] A variety of commercial lacquer preparations may be used to prepare the durable coatings described herein. Among the commercial acrylic lacquers that may be employed are "Self-Etching Primer" (Eastwood Co., Pottstown, PA); DuPont VariPrime 615S (DuPont Performance Coatings, Wilmington, DE) and Nason 491-17 Etch Primer (DuPont Performance Coatings, Wilmington, DE).

[00042] Lacquers may be used on a variety of surfaces, and are particularly useful in forming coatings on plastics, woods, and metals, including, but not limited to, metals (steel, stainless steel, and aluminum), plastics, and rubbers.

4.1.2 Polyurethane Binders

[00043] A wide variety of polyurethanes, including those prepared in organic solvent or in water may be used to prepare hydrophobic and/or oleophobic coatings described herein. Polyurethanes are polymers consisting of a chain of organic units joined by urethane (carbamate) linkages. Polyurethane polymers are typically formed through polymerization of at least one type of monomer containing at least two isocyanate functional groups with at least one other monomer containing at least two hydroxyl (alcohol) groups. A catalyst may be employed to speed the polymerization reaction. Other components may be present in the polyurethane coating compositions to impart desirable properties including, but not limited to, surfactants and other additives that bring about the carbamate forming reaction(s) yielding a coating of the desired properties in a desired cure time.

[00044] In some embodiments, the polyurethane employed in the durable coatings may be formed from a polyisocyanate and a mixture of -OH (hydroxyl) and NH (amine) terminated monomers. In such systems the polyisocyanate can be a trimer or homopolymer of hexamethylene diisocyanate.

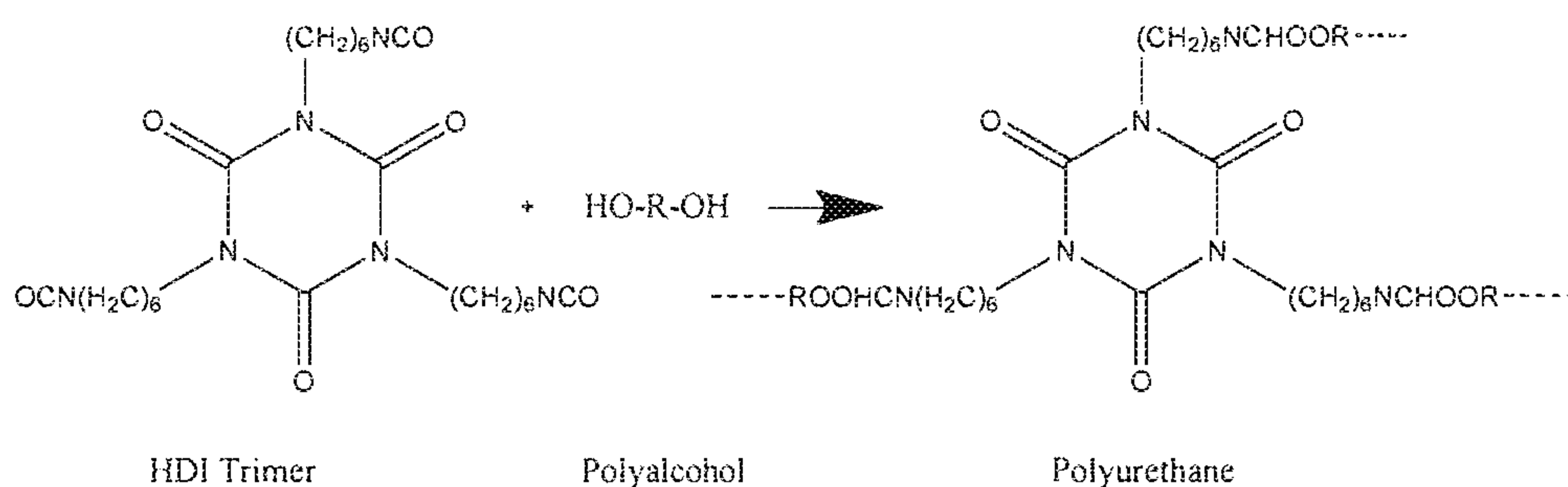

[00045] Some solvents compatible with such systems include n-butyl acetate, toluene, xylene, ethyl benzene, cyclohexanone, isopropyl acetate, and methyl isobutyl ketone and mixtures thereof.

[00046] In some embodiments, polyurethanes that are hydrophobic as applied in the absence of first or second particles described below may be employed to prepare the coatings described herein. Among the commercial polyurethanes that may be employed are the POLANE® family of polyurethanes from Sherwin Williams (Cleveland, OH).

[00047] Polyurethanes may come as a single component ready to apply composition, or as a two or three part (component) system, as is the case with POLANE® products. For example POLANE® B can be prepared by mixing POLANE® B (typically six parts), to a catalyst (e.g., typically one part of V66V27 or V66V29 from Sherwin Williams), and a reducer (typically 25 to 33% of R7K84 from Sherwin Williams). The "pot life" of mixed POLANE® B prepared in that manner is typically 6-8 hours.

[00048] A variety of water-based polyurethane compositions (aqueous polyurethane suspensions, emulsions, dispersions, gels etc.) may be employed may be used to prepare hydrophobic and/or oleophobic coatings described herein. Some commercially available water-based polyurethane compositions include POLANE® 700T and KEM AQUA® (Sherwin-Williams), and Bayhydrol 124 (Bayer Material Science), which may be used alone or in combination.

[00049] Polyurethane binders are compatible with, and show good adhesion to, a wide variety of surfaces. Using polyurethane binders, hydrophobic coatings may be formed on many, if not most surfaces including, but not limited to, those of metals, glass, rubber and plastics.

4.1.3 Fluoropolymer Binders

[00050] In other embodiments, a wide variety of fluoropolymer compositions may be used as binders in the preparation of hydrophobic and/or oleophobic (HP/OP) coatings described herein. Fluoropolymers are polymers comprising one or more fluoroalkyl groups. In some embodiments, the fluoropolymers employed in the durable coatings may be formed from fluoroethylene/vinyl ether copolymer (FEVE). Fluoropolymers that are hydrophobic as applied, in the absence of first or second particles which are described further below, may be employed to prepare the coatings described herein. Among the commercial fluoropolymers that may be employed to prepare HP/OP coatings are LUMIFLON® family polymers (Asahi Glass Co., Toyko, Japan).

[00051] Fluoropolymers that may be employed as binders typically come as a two or three component system, as is the case with LUMIFLON® products. For example LUMIFLON® LF can be prepared by mixing 58 parts of LUMIFLON® LF-200, 6.5 parts of DESMODUR® N3300A (Bayer Material Sciences, Leverkusen, Germany) 2.5 parts of catalyst (DABCO T12 (1/10,000 part), DABCO

(1,4-diazabicyclo[2.2.2]octane, 1/10,000 part), 1 part xylene), with 33 parts xylene. Unless otherwise noted, references to LUMIFLON[®], particularly in the Examples, refer to LUMIFLON[®] LF.

Fluoropolymer coatings such as LUMIFLON[®] can be applied to a variety of surfaces including wood, metal, rubber, and plastic.

4.2 First Particles

[00052] Embodiments of the coatings disclosed herein may comprise particles that are added to the binder compositions to improve the mechanical properties of the coating, *e.g.*, the durability of the hydrophobic and/or oleophobic coatings. A wide variety of such particles, which are denoted herein as "first particles" because the coatings described herein optionally may have one or more additional types of particles, also known as extenders or fillers, may be added to the binders. Such first particles that may be employed in the HP/OP coatings include, but are not limited to, particles comprising: wood (*e.g.*, wood dust), glass, metals (*e.g.*, iron, titanium, nickel, zinc, tin), alloys of metals, metal oxides, metalloid oxides (*e.g.*, silica), plastics (*e.g.*, thermoplastics), carbides, nitrides, borides, spinels, diamond, and fibers (*e.g.*, glass fibers).

[00053] Numerous variables may be considered in the selection of first particles. These variables include, but are not limited to, the effect the first particles have on the resulting coatings, their size, their hardness, their compatibility with the binder, the resistance of the first particles to the environment in which the coatings will be employed, and the environment the first particles must endure in the coating process, including resistance to temperature and solvent conditions.

[00054] In embodiments described herein, first particles have an average size in a range selected from about 1 micron (μm) to about 250 μm . Within such broader range, embodiments include ranges of first particles having an average size of from about 1 μm to about 5 μm , from about 5 μm to about 10 μm , from about 10 μm to about 15 μm , about 15 μm to about 20 μm , from about 20 μm to about 25 μm , from about 1 μm to about 25 μm , from about 5 μm to about 25 μm , from about 25 μm to about 50 μm , from about 50 μm to about 75 μm , from about 75 μm to about 100 μm , from about 100 μm to about 125 μm , from about 125 μm to about 150 μm , from about 150 μm to about 175 μm , from about 175 μm to about 200 μm , from about 200 μm to about 225 μm , and from about 225 μm to about 250 μm . Also included within the broader range are embodiments employing particles in ranges of from about 10 μm to about 100 μm , from about 10 μm to about 200 μm , from about 20 μm to about 200 μm , from about 30 μm to about 50 μm , from about 30 μm to about 100 μm , from about 30 μm to about 200 μm , from about 30 μm to about 225 μm , from about 50 μm to about 100 μm , from about 50 μm to about 200 μm , from about 75 μm to about 150 μm , from about 75 μm to about 200 μm , from about 100 μm to about 225 μm , from about 100 μm to about 250 μm , from about 125 μm to about 225 μm , from about 125 μm to about 250 μm , from about 150 μm to about 200 μm , from about 150 μm to about 250 μm , from about 175 μm to about 250 μm , and from about 200 μm to about 250 μm .

[00055] First particles may be incorporated into binders at various ratios depending on the binder composition and the first particle's properties. In some embodiments, the first particles may have a content range selected from: about 1% to about 60% or more by weight. Included within this broad range

are embodiments in which the first particles are present, by weight, in ranges of from about 2% to about 5%, from about 5% to about 10%, from about 10% to about 15%, from about 15% to about 20%, from about 20% to about 25%, from about 25% to about 30%, from about 30% to about 35%, from about 35% to about 40%, from about 40% to about 45%, from about 45% to about 50%, from about 50% to about 55%, from about 55% to about 60%, and greater than 60%. Also included within this broad range are embodiments in which the first particles are present, by weight, in ranges of from about 4% to about 30%, from about 5% to about 25%, from about 5% to about 35%, from about 10% to about 25%, from about 10% to about 30%, from about 10% to about 40%, from about 10% to about 45%, from about 15% to about 25%, from about 15% to about 35%, from about 15% to about 45%, from about 20% to about 30%, from about 20% to about 35%, from about 20% to about 40%, from about 20% to about 45%, from about 20% to about 55%, from about 25% to about 40%, from about 25% to about 45%, from about 25% to about 55%, from about 30% to about 40%, from about 30% to about 45%, from about 30% to about 55%, from about 30% to about 60%, from about 35% to about 45%, from about 35% to about 50%, from about 35% to about 60%, or from about 40% to about 60% on a weight basis.

[00056] In some embodiments, where the first particles comprise or consist of glass spheres, the first particles may be present in any of the foregoing ranges or in a range of from about 1% to about 40%, from about 3% to about 45%, from about 10% to about 45%, or from about 2% to about 15% on a weight basis.

[00057] In other embodiments where the first particles are a polyethylene or modified polyethylene, the particle may be present in a content range selected from any of the foregoing ranges, or in a range of from about 3% to about 20%, from about 3% to about 15%, or from about 3% to about 10% on a weight basis.

[00058] The incorporation of first particles can lead to a surface that is textured due to the presence of the first particles. In such embodiments, the presence of the first particles results in a surface texture that has elevations on the level of the coating formed. The height of the elevations due to the presence of the first particles can be from 0 (where the first particle is just below the line of the binders surface) to a point where the first particles are almost completely above the level of the binder coating (although they may still be coated with binder). Thus, the presence of first particles can result in a textured surface wherein the first particles cause such elevations in the binder that have maximum heights in a range of up to almost about 250 μm . Accordingly, such elevations can be present in ranges of from about 1 μm to about 5 μm , from about 1 μm to about 10 μm , from about 1 μm to about 15 μm , about 1 μm to about 20 μm , from about 1 μm to about 25 μm , from about 1 μm to about 50 μm , from about 1 μm to about 75 μm , from about 1 μm to about 100 μm , from about 1 μm to about 125 μm , from about 1 μm to about 150 μm , from about 1 μm to about 175 μm , from about 1 μm to about 200 μm , from about 1 μm to about 225 μm , from about 1 μm to about 250 μm , from about 10 μm to about 80 μm , from about 15 to about 80 μm , from about 20 to about 100 μm , and from about 30 to about 70 μm .

[00059] The surface texture of coatings may also be assessed using the arithmetical mean roughness (Ra) or the ten point mean roughness (Rz) as a measure of the surface texture. In some

embodiments, a coating described herein has an arithmetical mean roughness (Ra) in a range selected from: about 0.2 μm to about 20 μm ; about 0.3 μm to about 18 μm ; about 0.2 μm to about 8 μm ; about 8 μm to about 20 μm ; or about 0.5 μm to about 15 μm . In other embodiments, a coating as described herein has a ten point mean roughness (Rz) in a range selected from: about 1 μm to about 90 μm ; about 2 μm to about 80 μm ; about 3 μm to about 70 μm ; about 1 μm to about 40 μm ; about 40 μm to about 80 μm ; about 10 μm to about 65 μm ; or about 20 μm to about 60 μm .

[00060] First particles may optionally comprise moieties that make them hydrophobic and/or oleophobic. Where it is desirable to introduce such moieties the particles may be reacted with reagents that covalently bind moieties that make them hydrophobic and/or oleophobic. In some embodiments, the reagents may be silanizing agents, such as those that introduce alkyl, haloalkyl, fluoroalkyl or perfluoroalkyl moieties (functionalities). In some embodiments the silanizing agents are compounds of formula (I) (*i.e.*, $R_{4-n}\text{Si-X}_n$), and the various embodiments of compounds of formula (I) described below for the treatment of second particles. The surface of many types of first particles can be activated to react with silanizing agents by various treatments including exposure to acids, bases, plasma, and the like, where necessary to achieve functionalization of the particles.

[00061] In embodiments described herein, the first particles are not modified by adding functional groups that impart one or more of hydrophobic and/or oleophobic properties to the particles (*e.g.*, properties beyond the properties inherent to the composition forming the particles). In one such embodiment, first particles do not contain covalently bound alkyl, haloalkyl, fluoroalkyl or perfluoroalkyl functionalities (moieties). In another such embodiment, the first particles are not treated with a silanizing agent (*e.g.*, a compound of formula (I)).

4.3 Exemplary Sources of First Particles

[00062] First particles may be prepared from the diverse materials described above. Alternatively, first particles may be purchased from a variety of suppliers. Some commercially available first particles that may be employed in the formation of the hydrophobic and/or oleophobic (HP/OP) coatings described herein include those in the accompanying Table I.

Table I First Particles

Filler No.	Filler ID	Filler Type	Filler Details	Density (g/cc)	Particle Size Range (μm)	Color	Crush Strength (psi)	Source	Location
1	K1	Glass Bubbles	GPS ^a	0.125	30-120	White	250	3M TM	St. Paul, MN
2	K15	Glass Bubbles	GPS ^a	0.15	30-115	White	300	3M TM	St. Paul, MN
3	S15	Glass Bubbles	GPS ^a	0.15	25-95	White	300	3M TM	St. Paul, MN
4	S22	Glass Bubbles	GPS ^a	0.22	20-75	White	400	3M TM	St. Paul, MN
5	K20	Glass Bubbles	GPS ^a	0.2	20-125	White	500	3M TM	St. Paul, MN
6	K25	Glass Bubbles	GPS ^a	0.25	25-105	White	750	3M TM	St. Paul, MN

WO 2011/116005

PCT/US2011/028541

7	S32	Glass Bubbles	GPS ^a	0.32	20-80	White	2000	3M™	St. Paul, MN
8	S35	Glass Bubbles	GPS ^a	0.35	10-85	White	3000	3M™	St. Paul, MN
9	K37	Glass Bubbles	GPS ^a	0.37	20-85	White	3000	3M™	St. Paul, MN
10	S38	Glass Bubbles	GPS ^a	0.38	15-85	White	4000	3M™	St. Paul, MN
11	S38HS	Glass Bubbles	GPS ^a	0.38	15-85	White	5500	3M™	St. Paul, MN
12	K46	Glass Bubbles	GPS ^a	0.46	15-80	White	6000	3M™	St. Paul, MN
13	S60	Glass Bubbles	GPS ^a	0.6	15-65	White	10000	3M™	St. Paul, MN
14	S60/HS	Glass Bubbles	GPS ^a	0.6	11-60	White	18000	3M™	St. Paul, MN
15	A16/500	Glass Bubbles	Floated Series	0.16	35-135	White	500	3M™	St. Paul, MN
16	A20/1000	Glass Bubbles	Floated Series	0.2	30-120	White	1000	3M™	St. Paul, MN
17	H20/1000	Glass Bubbles	Floated Series	0.2	25-110	White	1000	3M™	St. Paul, MN
18	D32/4500	Glass Bubbles	Floated Series	0.32	20-85	White	4500	3M™	St. Paul, MN
19	H50/10000 EPX	Glass Bubbles	Floated Series	0.5	20-60	White	10000	3M™	St. Paul, MN
20	iMK	Glass Bubbles	Floated Series	0.6	8.6-26.7	White	28000	3M™	St. Paul, MN
21	G-3125	Z-Light Spheres™	CM ^b	0.7	50-125	Gray	2000	3M™	St. Paul, MN
22	G-3150	Z-Light Spheres™	CM ^b	0.7	55-145	Gray	2000	3M™	St. Paul, MN
23	G-3500	Z-Light Spheres™	CM ^b	0.7	55-220	Gray	2000	3M™	St. Paul, MN
24	G-600	Zeeo-spheres™	CM ^b	2.3	1-40	Gray	>60000	3M™	St. Paul, MN
25	G-800	Zeeo-spheres™	CM ^b	2.2	2-200	Gray	>60000	3M™	St. Paul, MN
26	G-850	Zeeo-spheres™	CM ^b	2.1	12-200	Gray	>60000	3M™	St. Paul, MN
27	W-610	Zeeo-spheres™	CM ^b	2.4	1-40	White	>60000	3M™	St. Paul, MN
28	SG	Extendo-sphere™	HS ^c	0.72	30-140	Gray	2500	Sphere One	Chattanooga, TN
29	DSG	Extendo-sphere™	HS ^c	0.72	30-140	Gray	2500	Sphere One	Chattanooga, TN
30	SGT	Extendo-sphere™	HS ^c	0.72	30-160	Gray	2500	Sphere One	Chattanooga, TN
31	TG	Extendo-sphere™	HS ^c	0.72	8-75	Gray	2500	Sphere One	Chattanooga, TN
32	SLG	Extendo-sphere™	HS ^c	0.7	10-149	Off White	3000	Sphere One	Chattanooga, TN
33	SLT	Extendo-sphere™	HS ^c	0.4	10-90	Off White	3000	Sphere One	Chattanooga, TN
34	SL-150	Extendo-sphere™	HS ^c	0.62	70	Cream	3000	Sphere One	Chattanooga, TN
35	SLW-150	Extendo-sphere™	HS ^c	0.68	8-80	White	3000	Sphere One	Chattanooga, TN
36	HAT	Extendo-sphere™	HS ^c	0.68	10-165	Gray	2500	Sphere One	Chattanooga, TN
37	HT-150	Extendo-	HS ^c	0.68	8-85	Gray	3000	Spher	Chattano

		sphere™						e One	oga, TN
38	KLS-90	Extendo-sphere™	HS ^c	0.56	4-05	Light Gray	1200	Spher e One	Chattano oga, TN
39	KLS-125	Extendo-sphere™	HS ^c	0.56	4-55	Light Gray	1200	Spher e One	Chattano oga, TN
40	KLS-150	Extendo-sphere™	HS ^c	0.56	4-55	Light Gray	1200	Spher e One	Chattano oga, TN
41	KLS-300	Extendo-sphere™	HS ^c	0.56	4-55	Light Gray	1200	Spher e One	Chattano oga, TN
42	HA-300	Extendo-sphere™	HS ^c	0.68	10-146	Gray	2500	Spher e One	Chattano oga, TN
43	XIOM 512	Thermo-plastic	MPR ^d	0.96	10-100	White	508	XIOM Corp.	West Babylon, NY
44	XIOM 512	Thermo-plastic	MPR ^d	0.96	10-100	Black	508	XIOM Corp.	West Babylon, NY
45	CORVEL™ Black 78-7001	Thermo-plastic	Nylon Powder Coating	1.09	44-74	Black		ROH M & HASS	Philadelph ia, PA
46	Microglass 3082	Fibers	MMEG F ^e	1.05	16X120	White		Fibert ec	Bridgew ater, MA
47	Microglass 9007D	Fibers Silane-Treated	MMEG F ^e	0.53	10X150	White		Fibert ec	Bridgew ater, MA

4.4 Second Particles

[00063] Embodiments of the coatings disclosed herein also may employ second particles (*e.g.*, nanoparticles), including those which bear hydrophobic moieties. A variety of second particles can be used to prepare the hydrophobic coatings applied to the plungers described herein. Suitable second particles have a size from about 1 nano meter (nm) to about 25 μm and are capable of binding covalently to one or more chemical moieties(groups or components) that provide the second particles, and the coatings into which they are incorporated, hydrophobicity, and when selected to include fluoroalkyl groups, oleophobicity.

[00064] In some embodiments the second particles may have an average size in a range selected from about 1 nm to up to about 25 μm or more. Included within this broad range are embodiments in which the second particles have an average size in a range of from about 1 nm to about 10 nm, from about 10 nm to about 25 nm, from about 25 nm to about 50 nm, from about 50 nm to about 100 nm, from about 100 nm to about 250 nm, from about 250 nm to about 500 nm, from about 500 nm to about 750 nm, from about 750 nm to about 1 μm , from about 1 μm to about 5 μm , from about 5 μm to about 10 μm , from about 10 μm to about 15 μm , from about 15 μm to about 20 μm , from about 20 μm to about 25 μm , from 1 nm to about 100 nm, from about 2 nm to about 200 nm, from about 10 nm to about 200 nm, from about 20 nm to about 400 nm, from about 10 nm to about 500 nm; from about 40 nm to about 800 nm, from about 100 nm to about 1 μm , from about 200 nm to about 1.5 μm , from about 500 nm to about 2 μm , from about 500 nm to about 2.5 μm , from about 1.0 μm to about 10 μm , from about 2.0 μm to about 20 μm , from about 2.5 μm to about 25 μm , from about 500 nm to about 25 μm , from about 400 nm to about 20 μm , and from about 100 nm to about 15 μm , from about 1 nm to about 50 nm, from about 1 nm

to about 400 nm, from about 1 nm to about 500 nm, from about 2 nm to about 120 nm, from about 5 nm to about 100 nm, from about 5 nm to about 200 nm; from about 5 nm to about 400 nm; about 10 nm to about 300 nm; or about 20 nm to about 400 nm..

[00065] In the above-mentioned embodiments, the lower size of second particles may be limited to particles greater than about 20 nm, about 25 nm, about 30 nm, about 35 nm, about 40 nm, about 45 nm, about 50 nm, or about 60 nm; and the upper size of second particles may be limited to particles less than about 20 μm , about 10 μm , about 5 μm , about 1 μm , about 0.8 μm , about 0.6 μm , about 0.5 μm , about 0.4 μm , about 0.3 μm or about 0.2 μm . Limitations on the upper and lower size of second particles may be used alone or in combination with any of the above-recited size limits on particle composition, percent composition in the coatings, etc.

[00066] In some embodiments, the coatings may contain first particles in any of the above-mentioned ranges subject to either the proviso that the coatings do not contain only particles (*e.g.*, first or second particles) with a size of 25 μm or less, or the proviso that the coatings do not contain more than an insubstantial amount of particles with a size of 25 μm or less (recognizing that separation processes for particles of size that is greater than 25 μm may ultimately provide an unintended, insubstantial amount of particles that are 25 μm or less).

[00067] In other embodiments, first particles have an average size greater than 30 μm and less than 250 μm , and do not contain substantial amounts of particles (*e.g.*, first and second particles) with a size of 30 μm or less. In yet other embodiments, the coatings do not contain only particles (*e.g.*, first and second particles) with a size of 40 μm or less, or particles with a size of 40 μm or less in substantial amounts. And in still other embodiments, the coatings do not contain only particles (*e.g.*, first and second particles) with a size of 50 μm or less, or particles with a size of 50 μm or less in substantial amounts.

[00068] In other one embodiments, such as where the second particles are prepared by fuming (*e.g.*, fumed silica or fumed zinc oxide), the second particles may have an average size in a range selected from about 1 nm to about 50 nm; about 1 nm to about 100 nm; about 1 nm to about 400 nm; about 1 nm to about 500 nm; about 2 nm to about 120 nm; about 5 nm to about 100 nm; about 5 nm to about 200 nm; about 5 nm to about 400 nm; about 10 nm to about 300 nm; or about 20 nm to about 400 nm.

[00069] Second particles having a wide variety of compositions may be employed in the durable coatings described and employed herein. In some embodiments the second particles will be particles comprising metal oxides (*e.g.*, aluminum oxides such as alumina, zinc oxides, nickel oxides, zirconium oxides, iron oxides, or titanium dioxides), or oxides of metalloids (*e.g.*, oxides of B, Si, Sb, Te and Ge) such as a glass, silicates (*e.g.*, fumed silica), or particles comprising combinations thereof. The particles are treated to introduce one or more moieties (*e.g.*, groups or components) that impart hydrophobicity and/or oleophobicity to the particles, either prior to incorporation into the compositions that will be used to apply coatings or after incorporation into the coatings. In some embodiments, the second particles are treated with a silanizing agent, a siloxane or a silazane to incorporate groups that will provide hydrophobic and/or oleophobic properties to the particles (in addition to any such properties already

possessed by the particles). When treated after incorporation into the coatings, only those particles at or near the surface that can be contacted with suitable agents such as silanizing agents will have moieties that impart hydrophobicity and/or oleophobicity associated with them.

[00070] In some embodiments, second particles are silica (silicates), alumina (*e.g.*, Al₂O₃), titanium oxide, or zinc oxide, that are optionally treated with a silanizing agent.

[00071] In embodiments, the second particles are silica (silicates), glass, alumina (*e.g.*, Al₂O₃), a titanium oxide, or zinc oxide, which optionally may be treated with a silanizing agent, a siloxane or a silazane. In some embodiments, the second particles may be prepared by fuming (*e.g.*, fumed silica or fumed zinc oxide).

4.5 Some Sources of Second Particles

[00072] Second particles such as fumed silica may be purchased from a variety of suppliers, including but not limited to Cabot Corp., Billerica, MA (*e.g.*, Nanogel TLD201, CAB-O-SIL® TS-720, and M5 (untreated silica)) and Evonik Industries, Essen, Germany (*e.g.*, ACEMATT® silica such as untreated HK400, AEROXIDE® TiO₂ titanium dioxide, and AEROXIDE® Alu alumina).

[00073] Some commercially available second particles are set forth in Scheme I.

Scheme I

CAB-O-SIL Grade	Surface Treatment	Level of Treatment	Nominal BET Surface Area of Base Silica (m ² /g)
M-5	None	None	200
TS-610	Dimethyldichlorosilane ^b	Intermediate	130
TS-530	Hexamethyldisilazane ^b	High	320
TS-382	Octyltrimethoxysilane ^b	High	200
TS-720	Polydimethylsiloxane ^b	High	200

^aData from Cabot Corp. website.

Dimethyldichlorosilane

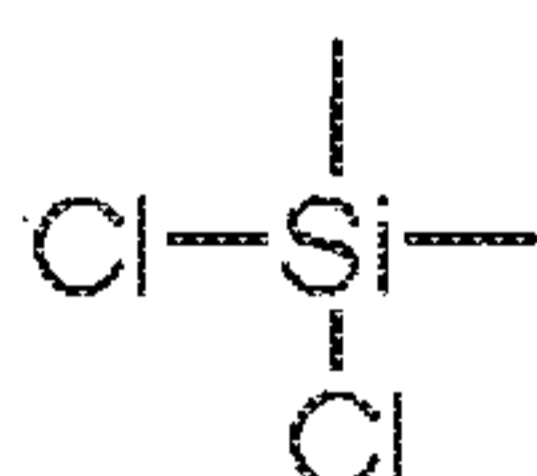

Hexamethyldisilazane

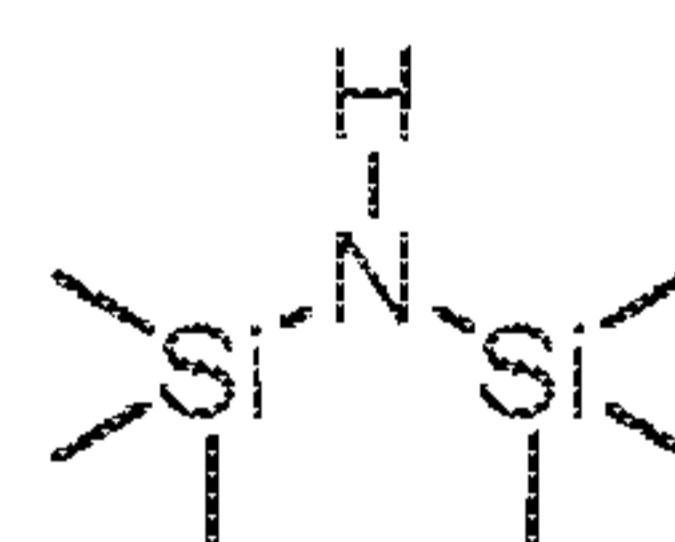

Polydimethylsiloxane

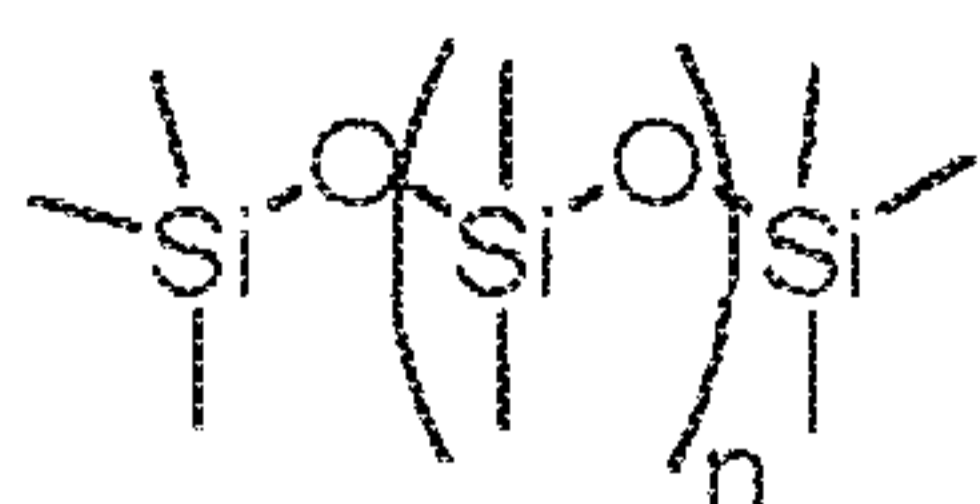

Octyltrimethoxysilane

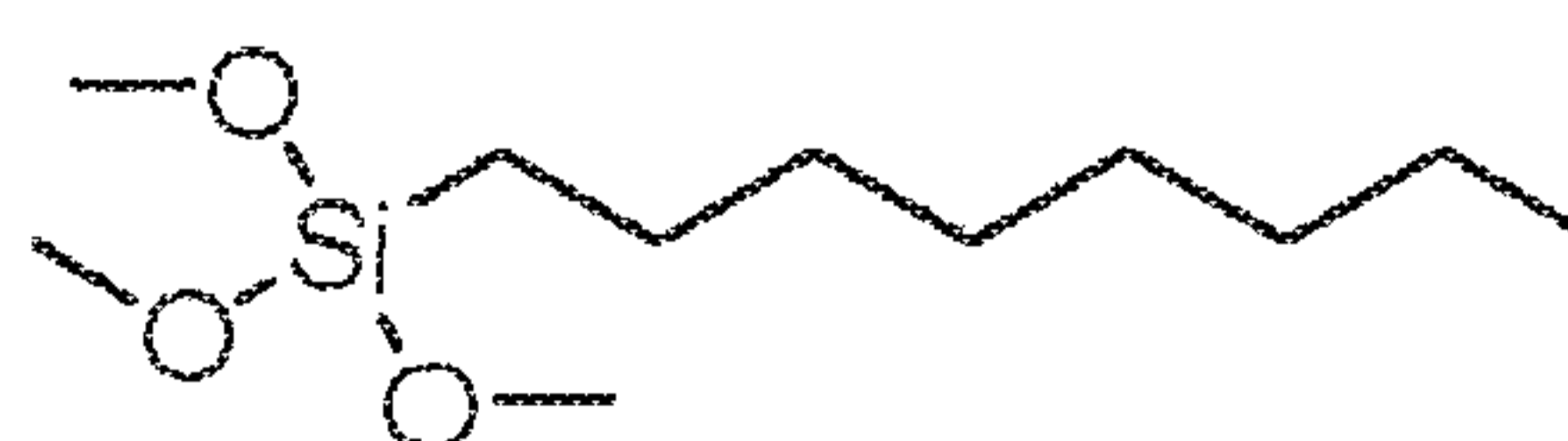

As purchased, the second particles may be untreated (*e.g.*, M5 silica) and may not possess any HP/OP properties. Such untreated particles can be treated to covalently attach one or more groups or moieties to the particles that give them HP/OP properties, for example, by treatment with the silanizing agents discussed above.

5.0 HYDROPHOBIC AND OLEOPHOBIC MOIETIES OF FIRST AND/OR SECOND PARTICLES

[00074] As discussed above, both the first and second particles may comprise one or more independently selected moieties that impart hydrophobic and/or oleophobic properties to the particles, and the coatings into which they are incorporated. As also noted above, such chemical entities may be inherently associated with the particles themselves and/or added by way of treating the particles. Although first particles may be treated to make them hydrophobic and/or oleophobic either before or after incorporation into the coating compositions described herein, the second particles typically will be treated with agents that introduce such moieties before being incorporated into the coatings described herein. It is also possible to treat the coating after it is applied to a surface with agents that modify the second particles and introduce hydrophobic and/or oleophobic properties. In such circumstances, other components of the coating (*e.g.*, the binder or first particles) may also become modified by the agent.

[00075] In some embodiments, the second particles will bear one or more alkyl, haloalkyl, fluoroalkyl, and perfluoroalkyl moieties. Such moieties can be covalently bound directly or indirectly bound to the second particle, such as through one or more intervening silicon or oxygen atoms.

[00076] In other embodiments, the second particles will bear one or more alkyl, haloalkyl, fluoroalkyl, and perfluoroalkyl moieties of the formula $R_{3-n}Si-$, where n is from 1-3, that are directly or indirectly (*e.g.*, covalently bound) to the second particle, such as through one or more intervening atoms.

5.1 Silanizing Agents and their Use

[00077] A variety of silanizing agents (*e.g.*, compounds of the formula $R_{4-n}Si-X_n$) can be employed to introduce moieties, *e.g.*, $R_{3-n}Si-$ groups (where n is an integer from 0 to 2), to the first or second particles prior to or subsequent to their introduction into the coatings described herein. Suitable silanizing agents typically have both leaving groups and terminal functionalities. Terminal functionalities are groups that are not displaced by reaction of a silanizing agent with silica second particles (*e.g.*, R groups of compounds of the formula (I)). Leaving groups are those groups that are displaced from silanizing agents upon reaction to form bonds with the second particles.

[00078] Prior to reacting first or second particles with silanizing agents, the particles may be treated with an agent that will increase the number of sites available for reaction with the silanizing agent (*e.g.*, $SiCl_4$, $Si(OMe)_4$, $Si(OEt)_4$, $SiCl_3CH_3$, $SiCl_3CH_2SiCl_3$, $SiCl_3CH_2CH_2SiCl_3$, $Si(OMe)_3CH_2Si(OMe)_3$, $Si(OMe)_3CH_2CH_2Si(OMe)_3$, $Si(OEt)_3CH_2Si(OEt)_3$, or $Si(OEt)_3CH_2CH_2Si(OEt)_3$ and the like). Treatment with such agents is conducted, *e.g.*, with a 1% to 5% solution of the agent in a suitable solvent (*e.g.*, hexane), although higher concentrations may be employed (*e.g.*, about 5% to about 10%). Where agents such as $SiCl_4$ or $Si(OMe)_4$ are employed to increase the number of sites available for reaction with silanizing agents, the surface may first be treated with $SiCl_4$ followed by reaction with water to replace

the chlorines with OH groups that react effectively with silanizing agents such as those of formula (I). Reaction with silanizing agents is typically conducted using a silanizing agent at in the range of about 1% to about 2% w/v, although concentrations in the range of about 2% to about 5% w/v may also be used. Depending on the reagents employed, the reaction, which often can be conducted at room temperature, is typically conducted for 1 hour to 6 hours, although reaction for as long as 24 hours may be desirable in some instances. Skilled artisans will appreciate that concentrations and reaction times and conditions other than those described above also might be able to be used.

[00079] In some embodiments, silanizing agents are compounds of the formula (I):

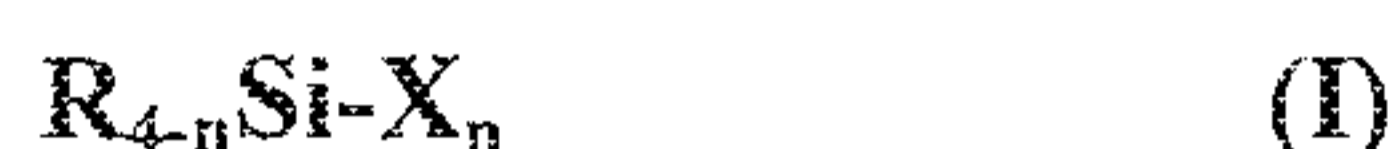

where n is an integer from 1-3;

each R is independently selected from

- (i) alkyl or cycloalkyl group optionally substituted with one or more fluorine atoms,
- (ii) C_{1 to 20} alkyl optionally substituted with one or more independently selected substituents selected from fluorine atoms and C₆₋₁₄ aryl groups, which aryl groups are optionally substituted with one or more independently selected halo, C_{1 to 10} alkyl, C_{1 to 10} haloalkyl, C_{1 to 10} alkoxy, or C_{1 to 10} haloalkoxy substituents,
- (iii) C_{6 to 20} alkyl ether optionally substituted with one or more substituents independently selected from fluorine and C_{6 to 14} aryl groups, which aryl groups are optionally substituted with one or more independently selected halo, C_{1 to 10} alkyl, C_{1 to 10} haloalkyl, C_{1 to 10} alkoxy, or C_{1 to 10} haloalkoxy substituents,
- (iv) C_{6 to 14} aryl, optionally substituted with one or more substituents independently selected from halo or alkoxy, and haloalkoxy substituents;
- (v) C_{4 to 20} alkenyl or C_{4 to 20} alkynyl, optionally substituted with one or more substituents independently selected from halo, alkoxy, or haloalkoxy; and
- (vi) -Z-((CF₂)_q(CF₃))_r, wherein Z is a C_{1 to 12} divalent alkane radical or a C₂₋₁₂ divalent alkene or alkyne radical, q is an integer from 1 to 12, and r is an integer from 1-4;

each X is an independently selected -H, -Cl, -I, -Br, -OH, -OR², -NHR³, or -N(R³)₂ group;

each R² is an independently selected C_{1 to 4} alkyl or haloalkyl group; and

each R³ is independently an independently selected H, C_{1 to 4} alkyl, or haloalkyl group.

[00080] In some embodiments, R is an alkyl or fluoroalkyl group having from 6 to 20 carbon atoms.

[00081] In other embodiments, R is an alkyl or fluoroalkyl group having from 8 to 20 carbon atoms.

[00082] In other embodiments, R is an alkyl or fluoroalkyl group having from 10 to 20 carbon atoms.

[00083] In other embodiments, R is an alkyl or fluoroalkyl group having from 6 to 20 carbon atoms and n is 3.

[00084] In other embodiments, R is an alkyl or fluoroalkyl group having from 8 to 20 carbon atoms and n is 3.

[00085] In other embodiments, R is an alkyl or fluoroalkyl group having from 10 to 20 carbon atoms and n is 3.

[00086] In other embodiments, R has the form $-Z-((CF_2)_q(CF_3))_r$, wherein Z is a C_{1-10} divalent alkane radical or a C_{2-10} divalent alkene or alkyne radical, q is an integer from 1 to 12, and r is an integer from 1 to 4.

[00087] In any of the previously mentioned embodiments of compounds of formula (I), the value of n may be varied such that 1, 2 or 3 independently selected terminal functionalities are present in compounds of formula (I). Thus, in some embodiments, n is 3. In other embodiments, n is 2, and in still other embodiments, n is 1.

[00088] In any of the previously mentioned embodiments of compounds of formula (I), all halogen atoms present in any one or more R groups may be fluorine.

[00089] In any of the previously mentioned embodiments of compounds of formula (I), X may be independently selected from H, Cl, $-OR^2$, $-NHR^3$, $-N(R^3)_2$, or combinations thereof. In other embodiments, X may be selected from Cl, $-OR^2$, $-NHR^3$, $-N(R^3)_2$, or combinations thereof. In still other embodiments, X may be selected from, $-Cl$, $-NHR^3$, $-N(R^3)_2$ or combinations thereof.

[00090] Any coating described herein may be prepared with one, two, three, four or more compounds of formula (I) employed alone or in combination to modify the first or second particles, and/or other components of the coating. For example, the same or different compounds of formula (I) may be employed to modify both the first particles and the binder.

[00091] The use of silanizing agents of formula (I) to modify first or second particles, or any of the other components of the coatings, will introduce one or more $R_{3-n}X_nSi-$ groups (e.g., R_3Si- , R_2X_1Si- , or RX_2Si- groups) where R and X are as defined for a compound of formula (I). The value of n is 0, 1, or 2, due to the displacement of at least one "X" substituent and formation of at least one bond between a particle and the Si atom (the bond between the particle and the silicon atom is indicated by a dash "-") (e.g., R_3Si- , R_2X_1Si- , or RX_2Si- groups).

[00092] Exemplary reagents that can be employed to prepare first or second particles with hydrophobic and/or oleophobic properties include silanizing agents such as those that are commercially available from Gelest, Inc., Morrisville, PA. Such silanizing agents include, but are not limited to, the following compounds, which are identified by their chemical name followed by the commercial supplier reference number (e.g., their Gelest reference in parentheses): (tridecafluoro-1,1,2,2-tetrahydrooctyl)silane (SIT8173.0); (tridecafluoro-1,1,2,2-tetrahydrooctyl)trichlorosilane (SIT8174.0); (tridecafluoro-1,1,2,2-tetrahydrooctyl)triethoxysilane (SIT8175.0); (tridecafluoro-1,1,2,2-tetrahydrooctyl)trimethoxysilane (SIT8176.0); (heptadecafluoro-1,1,2,2-tetrahydrodecyl)dimethyl(dimethylamino)silane (SIH5840.5); (heptadecafluoro-1,1,2,2-tetrahydrodecyl)tris(dimethylamino)silane (SIH5841.7); n-octadecyltrimethoxysilane (SIO6645.0); n-octyltriethoxysilane (SIO6715.0); and nonafluorohexyldimethyl(dimethylamino)silane (SIN6597.4).

[00093] Two attributes of silanizing agents that may be considered for the purposes of their reaction with first or second particles and the introduction of hydrophobic or oleophobic moieties are the leaving group (*e.g.*, X groups of compounds of the formula (I)) and the terminal functionality (*e.g.*, R groups of compounds of the formula (I)). A silanizing agent's leaving group(s) can determine the reactivity of the agent with the first or second particle(s) or other components of the coating. Where the first or second particles are a silicate (*e.g.*, fumed silica) the leaving group can be displaced to form Si-O-Si bonds. Leaving group effectiveness is ranked in the decreasing order as chloro > methoxy > hydro (H) > ethoxy (measured as trichloro > trimethoxy > trihydro > triethoxy). This ranking of the leaving groups is consistent with their bond dissociation energy. The terminal functionality determines the level of hydrophobicity that results from application of the silane to the surface.

[00094] In addition to the silanizing agents recited above, a variety of other silanizing agents can be used to alter the properties of first or second particles and to provide hydrophobic and/or oleophobic properties. In some embodiments, second particles may be treated with an agent selected from dimethyldichlorosilane, hexamethyldisilazane, octyltrimethoxysilane, polydimethylsiloxane, or tridecafluoro-1,1,2,2-tetrahydrooctyl trichlorosilane. In such embodiments, the second particles may be silica. Silica second particles treated with such agents may have an average size in a range selected from: about 1 nm to about 50 nm, from about 1 nm to about 100 nm, from about 1 nm to about 400 nm, from about 1 nm to about 500 nm, from about 2 nm to about 120 nm, from about 5 nm to about 150 nm, from about 5 nm to about 400 nm, from about 10 nm to about 300 nm, from about 20 nm to about 400 nm, or from about 50 nm to about 250 nm.

[00095] In addition to the silanizing agents recited above, which can be used to modify any one or more components of coatings (*e.g.*, first and/or second particles), other agents can be employed including, but not limited to, one or more of: gamma-aminopropyltriethoxysilane, Dynasylan[®] A (tetraethylorthosilicate), hexamethyldisilazane, and Dynasylan[®] F 8263 (fluoroalkylsilane), any one or more of which may be used alone or in combination with the silanizing agent recited herein.

5.2 Use of Compounds Other Than Silanizing Agents

[00096] Other agents also can be used to introduce hydrophobic and/or oleophobic moieties into second particles. The choice of such agents will depend on the functionalities available for forming chemical (covalent) linkages between hydrophobic/oleophobic moieties and the functional groups present on the second particles surface. For example, where second particle surfaces have, or can be modified to have, hydroxyl or amino groups, then acid anhydrides and acid chlorides of alkyl, fluoroalkyl, and perfluoroalkyl compounds may be employed (*e.g.*, the acid chlorides: Cl-C(O)(CH₂)₄₋₁₀₋₁₈CH₃; Cl-C(O)(CH₂)₄₋₁₀(CF₂)₂₋₁₀₋₁₄CF₃; Cl-C(O)(CF₂)₄₋₁₀₋₁₈CF₃ or the anhydrides of those acids).

5.3 Preparation of Plungers with Hydrophobic and Oleophobic Coatings.

[00097] As noted above, in addition to the hydrophobicity displayed against aqueous-based solutions, suspensions, and emulsions, the coatings described herein also have the ability to display oleophobic behavior, thereby further reducing the ability of materials destined for the sewer to attach to the surface of coated plungers. Oleophobicity will be exhibited by embodiments described herein,

particularly when the coatings comprise fluorinated or perfluorinated alkyl groups bound to first or second particles (*e.g.*, where the terminal functionality, that is the R group(s) of a silane of the formula $R_{4-n}Si-X_n$, are fluorinated alkyl or perfluoroalkyl).

6.0 METHODS OF APPLYING HYDROPHOBIC AND OLEOPHOBIC COATINGS

6.1 Portion of the Plunger Coated

[00098] All or only a portion of the cup and/or handle may be coated with a hydrophobic coating according to this disclosure. As the cup is the portion of the plunger with the most surface area that contacts standing water and other materials that are to enter sewage lines, in some embodiments the cup is the only portion of the plunger that is coated with a hydrophobic coating. Likewise, as only a part of the handle is typically immersed in water during the unclogging operation, in other embodiments only the cup and the part of the handle closest to the cup are treated to provide them with a hydrophobic surface (*e.g.*, by coating them). In some embodiments, less than one-half of the handle's length will be treated, and in other embodiments greater than one-half of the handle will be treated. In yet other embodiments, the entire plunger (the cup and handle) is treated/coated so that the surface of the plunger is hydrophobic. The application of hydrophobic coatings to household and industrial plungers are illustrated in Figs. 3-6.

6.2 Application of Coatings by One-Step and Two-Step Processes

[00099] The hydrophobic coatings described herein may be applied to substrates (*e.g.*, the surface of one or more parts of a plunger) using a variety of techniques, some of which can be grouped into one-step process and two-step processes. Within each of those categories numerous variations may be employed.

[000100] In one-step embodiments, the coating composition is substantially applied in a single step to the surfaces of an object (*e.g.*, a plunger) on which a hydrophobic surface is desired, although coatings applied by a one step method may subsequently be treated in one or more steps with one or more agents to increase the hydrophobicity of the coating or to effect some other modification of the properties of the hydrophobic coating or plunger. Exemplary coating compositions that can be applied in one step comprise a binder and at least one type of first particle and at least one type of second particle bearing a hydrophobic moiety. In some such embodiments, the coating may be treated with an agent that comprises a silanizing agent (*e.g.*, compositions comprising a compound of formula (I)). In other embodiments, coating hydrophobic compositions that comprise a binder and a first particle may be applied in a single step and subsequently treated by an agent comprising second particles according to this disclosure that, for example, bear hydrophobic and/or oleophobic chemical moieties such as fluoroalkyl groups.

[000101] In one embodiment, a one-step method of applying a coating to a substrate comprises applying a coating composition comprising: i) a binder; ii) first particles having a size of about 30 μm to about 225 μm ; and iii) second particles having a size of about 1 nm to about 25 μm bearing a hydrophobic moieties. Optionally, one or more independently selected alkyl, haloalkyl, or perfluoroalkyl groups may be covalently bound, either directly or indirectly, to the second particles prior to their

incorporation into the coating composition. One-step coating compositions may be diluted with any compatible solvents/liquids to assist in the application process.

[000102] In two-step methods, the coating composition is applied to a surface in two steps that comprise, respectively, the application of a first composition followed by the application of a second composition. In embodiments of a two-step method, the first composition comprises a binder and at least one type of first particles, and does not contain second particles that bear hydrophobic moieties. Once applied to the substrate, the first coating composition is termed a "substrate coating" or a "base coat(ing)." Following the application of the first coating composition, a second composition that is sometimes referred to as a "second coat(ing)" or "top coat(ing)" is applied to the base coating. The second composition comprises second particles bearing hydrophobic moieties (*e.g.*, alkyl or fluoroalkyl groups such as those introduced by reacting second particles with silanizing agents such as those of formula (I)).

[000103] In another embodiment a two-step method of forming a coating on at least a portion of a surface comprises: i) applying a composition comprising a binder to said surface, and ii) applying to said binder on said surface second particles having a size of about 1 nm to about 25 μm , wherein said second particles comprise one or more independently selected hydrophobic or oleophobic moieties; and wherein said applying to said comprises spray coating said second particles using a stream of gas (the second particles typically comprise less than about 2% by weight of a VOC (*e.g.*, a volatile solvent with a boiling point below 150° or 200° C at 1 atmosphere such as hexane, ethanol, and the like). In one variation of that method the composition comprising a binder further comprises first particles. In such an embodiment the first particles may have a size of about 1 μm to about 100 μm or of about 30 μm to about 225 μm (either average diameter or minimum diameter in any dimension). First particles, and their dimensions, are described elsewhere in this disclosure.

[000104] Second particles applied as part of the second coating composition in a two-step method may be applied either as a suspension in a suitable solvent that is compatible with the binder system (*e.g.*, hexane, xylene, and ethanol) or without a solvent using a spray gun (air spray gun) supplied with a suitable supply of compressed air, nitrogen, or other compressed gas (*e.g.*, a Binks Model 2001 or 2001V spray gun air spray gun; Binks, Inc., Glendale Heights, IL, supplied with air at about 50 psi may be employed).

[000105] In some embodiments a two-step method of applying a coating to a substrate comprises:
a) applying to the substrate a coating composition comprising i) a binder and ii) first particles having a size of about 30 μm to about 225 μm , to provide a base coating; and
b) applying to this base coating a composition containing second particles having a size of about 1 nm to about 25 μm .

[000106] The composition may also contain any necessary solvents/liquids to assist in the application process.

[000107] In one embodiment, the present specification includes and provides for a method of forming a hydrophobic coating on at least a portion of a surface comprising: i) applying a composition

comprising a binder on said surface and ii) applying to said binder on said surface second particles a having a size of about 1 nm to 25 μm wherein said second particles comprising one or more independently selected hydrophobic or oleophobic moieties; wherein said applying to said binder comprises spray coating of said second particles using a stream of gas; and wherein said second particles comprise less than 2% by weight of a solvent.

[000108] In another embodiment, the present specification includes and provides for a method of forming a hydrophobic coating on at least a portion of a surface comprising: i) applying a composition comprising a binder and first particles on said surface and ii) applying to said binder and first particles on said surface second particles a having a size of about 1 nm to 25 μm , wherein said second particles comprising one or more independently selected hydrophobic or oleophobic moieties; wherein said applying to said binder and first particles comprises spray coating of said second particles using a stream of gas; and wherein said second particles comprise less than 2% by weight of a solvent.

[000109] In one-step or two-step processes, the coatings may be applied using high or low VOC compositions (*e.g.*, water-based or aqueous binder compositions *etc.*). Where two step processes are used, either the first step of applying the base coat, the second step of applying a composition comprising second particles, or both steps may employ low VOC compositions. Where high VOC compositions are employed to for hydrophobic/oleophobic surfaces, it can be advantageous to employ equipment that can capture the volatile solvents and reuse or recycle them.

[000110] Coatings applied by a one-step or two-step methods may subsequently be treated with compositions comprising one or more agents to increase the hydrophobicity of the coating. In one embodiment, the agent is a silanizing agent (*e.g.*, the compositions comprising a compound of formula (I)). In another embodiment, the coating resulting from a one-step process can be treated with a composition comprising second particles that have been treated so that they bear hydrophobic moieties (*e.g.*, hydrophobic moieties or groups such as fluoroalkyl groups or dimethylsiloxanes). Where the coatings applied in one-step or two-step processes have not dried to the point that second particles can be incorporated, subsequent applications of second particles may be applied either in a binder compatible solvent, or with an air gun in the absence of a solvent as with the second step of a two-step process described above. In contrast, where coatings resulting from one-step or two-step process have already dried to the point where second particles cannot be incorporated into the coating in any significant amount (*e.g.*, an amount capable of altering the hydrophobicity of the coatings), second particles are generally applied in binder compatible solvents.

[000111] Coatings may be applied to substrates, or base coatings previously applied to substrates, by any method known in the art, including but not limited to: brushing, painting, dipping, spin coating, spraying, or electrostatic spraying.

6.3 Surface Preparation

[000112] To provide good adhesion of coatings (*e.g.*, the base coat of a two-step coating) to a surface (*e.g.*, the cup and handle parts of the plunger), the surfaces may be abraded to create some degree

of surface roughness. For plungers, the surface roughness of the cup and handle can be created by methods including: (1) scuffing with an abrasive pad (*e.g.*, Scotch-Brite™ pads), (2) fine sandblasting, (3) tumble blasting with small steel balls, and (4) coarse sandblasting. The surface roughness produced by different methods can be compared with the starting surface roughness. The surface roughness measured using a Mahr Pocket Surf PSI (Mahr Federal Inc., Providence, RI.) can be expressed using a variety of mathematical expressions including, but not limited to, the arithmetical mean roughness (Ra) and ten-point mean roughness (Rz), which are described in Scheme II below.

[000113] Scuffing with abrasive materials such as Scotch-Brite™ pads increases the roughness values of plastics, such as those used in plunger handles, from an Ra of about 0.2-0.3 μm to about 0.7-0.9 μm and the Rz from about 1.4 to about 7 μm . Sandblasting plastics with coarse sand produces a very rough surface where the Ra increases substantially into the range of about 5 to about 6 μm and the Rz increases to the range of about 30 to about 37 μm .

[000114] The surface of flexible materials, such as the cup of the plunger, can also be abraded to improve the adherence of the hydrophobic coatings. Scuffing with abrasive materials (*e.g.* Scotch-Brite™ pads) can increase the Ra of flexible materials such as rubber from the range of about 0.2 to about 0.35 μm to the range of about 0.4 to about 0.5 μm and the Rz from about 2 μm to the range of about 3 to about 4 μm . Fine sandblasting of flexible materials, such as rubber, increases the Ra into the range from about 0.60 to about 0.75 μm and the Rz from about 2 μm to the range from about 6 to about 7 μm . Tumbling with small steel balls can increase the Ra from about 0.28 to the range of about 0.3 to about 0.4 μm and the Rz from about 2.043 to about 3.28 μm . Coarse sandblasting increases the Ra from 0.3 to the range of about 5 to about 6 μm and the Rz to the range of about 30 to about 35 μm .

[000115] The adhesion of the base coat to the plunger cup and handle is increased by any level of roughening. However, the surface roughness produced by coarse sandblasting with Ra values of about 5.662 μm for the handle and about 5.508 μm for the cup or corresponding Rz values of about 33.05 and about 33.150 μm for the handle and cup, respectively, are considered too excessive, and they result in a less pleasing surface finish. Thus, surface roughening may be accomplished by a variety of techniques including, but not limited to: abrading with abrasive cloths or papers (*e.g.*, scuffing with sandpaper or a Scotch-Brite™ pad), sandblasting with fine sand, sand blasting with coarse sand (10-20 mesh), or tumbling with small metal (*e.g.*, steel) balls, fine sand (20-50 mesh), and fine alumina or other metal oxide or metalloid oxide powders.

Scheme II

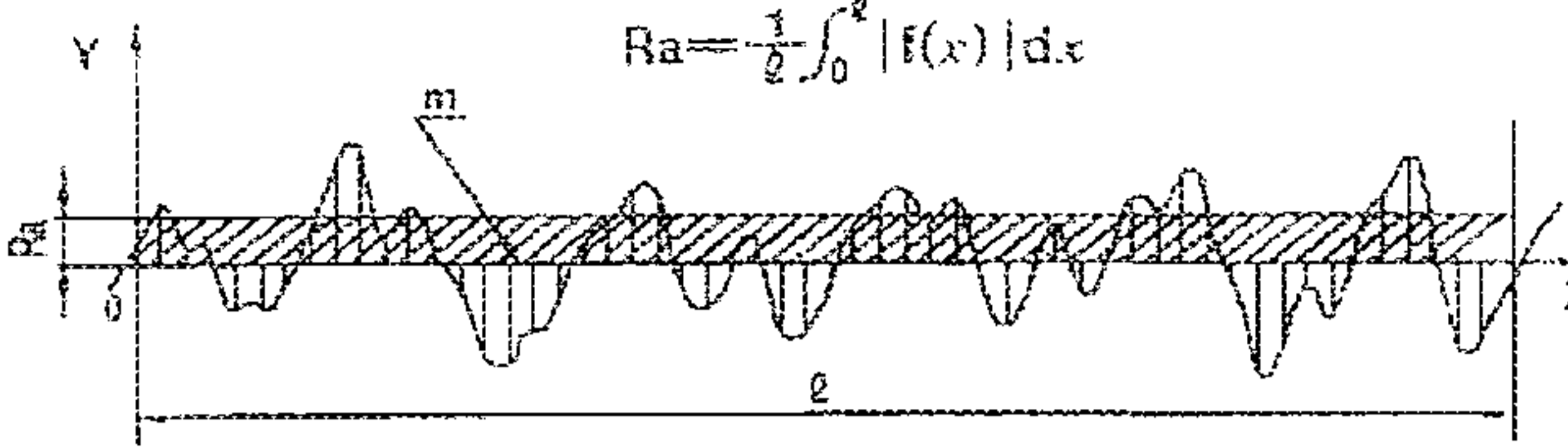
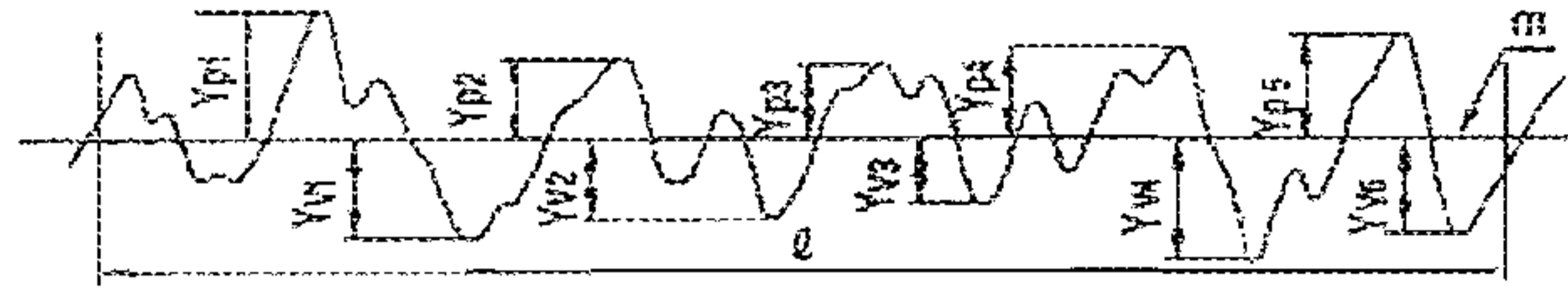
<p>Arithmetical mean roughness (Ra)</p> <p>A section of standard length is sampled from the mean line on the roughness chart. The mean line is laid on a Cartesian coordinate system wherein the mean line runs in the direction of the x-axis and magnification is the y-axis. The value obtained with the formula on the right is expressed in micrometer (μm) when $y=f(x)$.</p>	 <p>$Ra = \frac{1}{l} \int_0^l f(x) dx$</p>
<p>Ten-point mean roughness (Rz)</p> <p>A section of standard length is sampled from the mean line on the roughness chart. The distance between the peaks and valleys of the sampled line is measured in the y direction. Then, the average peak is obtained among 5 tallest peaks (Yp), as is the average valley between 5 lowest valleys (Yv). The sum of these two values is expressed in micrometer (μm).</p>	 <p>$Rz = \frac{ Yp1 + Yp2 + Yp3 + Yp4 + Yp5 + Yv1 + Yv2 + Yv3 + Yv4 + Yv5 }{5}$</p> <p>$Yp1, Yp2, Yp3, Yp4, Yp5$: Tallest 5 peaks within sample</p> <p>$Yv1, Yv2, Yv3, Yv4, Yv5$: Lowest 5 peaks within sample</p>

7.0 CERTAIN EMBODIMENTS

[000116] Embodiment 1. A plunger for clearing clogged plumbing, having a handle and a resilient collapsible cup comprising an outer surface and an inner surface, said outer and inner surface meeting at a rim, and said handle attaching to said outer surface, wherein said cup is coated with a hydrophobic coating, and wherein at least a portion of said handle is optionally coated with a hydrophobic coating.

[000117] Embodiment 2. The plunger of embodiment 1, wherein said hydrophobic coating comprises:

i) a binder; ii) first particles having a size of about 30 μm to about 225 μm ; and iii) second particles having a size of about 1 nm to 25 μm comprising one or more independently selected hydrophobic or oleophobic moieties; wherein said composition optionally contains 5% to 10% of a block copolymer on a weight basis.

[000118] Embodiment 3. The plunger of any of embodiments 1 or 2, wherein said hydrophobic coating comprises a base coat comprised of said binder and said first particles applied to said cup and optionally applied to said handle, and a top coat applied to said base coat comprised of said second particles.

[000119] Embodiment 4. The plunger of any of embodiments 1 to 3, wherein the outer surface of the cup is generally convex and said inner surface is generally concave.

[000120] Embodiment 5. The plunger of any of embodiments 1 to 4, wherein a cross section through the cup in a plane parallel to said rim is generally oval, elliptical, or oblate.

[000121] Embodiment 6. The plunger of any of embodiments 1 to 5, wherein a cross section through the cup in a plane parallel to the rim is generally circular.

[000122] Embodiment 7. The plunger of embodiment 5, wherein said handle is attached to said outer surface at a point that is approximately equidistant from the rim in each direction.

[000123] Embodiment 8. The plunger of any of embodiments 1 to 7, wherein plumbing is selected from a toilet, bathtub, shower, pipe, or sink.

[000124] Embodiment 9. The plunger according to embodiment 8, wherein said cup is adapted to conform to said plumbing.

[000125] Embodiment 10. The plunger of any of embodiments 1 to 9, wherein said hydrophobic coating is resistant to greater than 200, 250, 300, 350 or 400 abrasions cycles on Taber Model: 503 instrument using CS-10 wheels with 250 g load.

[000126] Embodiment 11. The plunger of any of embodiments 2 to 10, wherein said binder comprises a polyurethane.

[000127] Embodiment 12. The plunger of embodiment 11, wherein said polyurethane is a POLANE.

[000128] Embodiment 13. The plunger of any of embodiments 1 to 12, wherein said hydrophobic coating comprises about 5 to about 15% of first particles which are comprised of a material selected from: polymers, metals, glasses, glass bubbles, metalloid oxides, metal oxides, and cellulose.

[000129] Embodiment 14. The plunger of any of embodiments 2 to 13, wherein said second particles comprise;

(i) a metal oxides (*e.g.*, aluminum oxides, zinc oxides, nickel oxide, zirconium oxides, iron oxides, or titanium dioxide such as alumina), an oxide of a metalloid (*e.g.*, oxides of B, Si, Sb, Te and Ge such silica or fumed silica), or one or more metal oxides, oxides of metalloids or combination thereof (*e.g.*, glass particles); and

(ii) a silane, siloxane or a silizane, which may be covalently bound to said metal oxide, oxide of a metalloid, or a combination thereof.

[000130] Embodiment 15. The plunger of embodiment 14, wherein said silane, siloxane or silizane are selected from polydimethylsiloxane (PDMS) and hexamethyldisilazane.

[000131] Embodiment 16. The plunger of any of embodiments 1 to 15, wherein said hydrophobic coating is resistant to 40, 50, 60, 70, 80, 90, or 100 abrasion cycles on a Taber Model: 503 instrument using CS-10 wheels with 250 g load.

[000132] Embodiment 17. The plunger of any of embodiments 3 to 16, wherein said binder comprises an water-based polyurethane.

[000133] Embodiment 18. The plunger of embodiment 17, wherein said water-based polyurethane is a Polane™.

[000134] Embodiment 19. The plunger of any of embodiments 3 to 18, wherein said base coat comprises about 5 to about 15% of first particles which are comprised of a material selected from: polymers, metals, glasses, glass bubbles, metalloid oxides, metal oxides, or cellulose.

[000135] Embodiment 20. The plunger of any of embodiments 1 to 19, wherein said second particles are silica particles treated with a silanizing agent (*e.g.*, a compound of formula (I)).

[000136] Embodiment 21. The plunger of embodiment 20, wherein said silanizing agent is selected from (tridecafluoro-1,1,2,2-tetrahydrooctyl)silane (SIT8173.0); (tridecafluoro-1,1,2,2-tetrahydrooctyl) trichlorosilane (SIT8174.0); (tridecafluoro-1,1,2,2-tetrahydrooctyl)triethoxysilane (SIT8175.0); (tridecafluoro-1,1,2,2-tetrahydrooctyl)trimethoxysilane (SIT8176.0); (heptadecafluoro-1,1,2,2-tetrahydrodecyl)dimethyl(dimethylamino)silane (SIH5840.5); (heptadecafluoro-1,1,2,2-tetrahydrodecyl)tris(dimethylamino)silane (SIH5841.7); n-octadecyltrimethoxysilane (SIO6645.0); n-octyltriethoxysilane (SIO6715.0); and nonafluorohexyldimethyl(dimethylamino)silane (SIN6597.4).

[000137] Embodiment 22. The plunger of any of embodiments 1 to 21, wherein the coating on said cup and/or at least a portion of said handle has an arithmetical roughness value from about 0.44 to about 5.51 μm or a ten point mean roughness from about 0.9 to about 5.7 μm .

[000138] Embodiment 23. The plunger of any of embodiments 1-22, wherein less than about 0.2, 0.5, 1, 2, 3, or 4, grams of water remain bound to the surface after immersion in water at about 20°C.

[000139] Embodiment 24. The plunger according to embodiment 23, wherein less than about 0.2, 0.5, 1, 2, 3, or 4, grams of water remain bound to the surface after immersion in water at about 20°C after the handle has been used to compress the cup more than about 100, 200, or 300 times.

[000140] Embodiment 25. The plunger of any of embodiments 1 to 24, wherein the coating further comprises silver particles

[000141] Embodiment 26. The plunger of any of embodiments 3 to 25, wherein the base coat, top coat or both the base and top coat further comprise silver particles (e.g., silver nanoparticles for antibacterial action).

[000142] Embodiment 27. A method of forming a hydrophobic coating on at least a portion of a surface comprising:

- i) applying a composition comprising a binder on said surface, wherein said binder optionally comprises one or more first particles; and
- ii) applying to said binder on said surface second particles having a size of about 1 nm to 25 μm wherein said second particles comprising one or more independently selected hydrophobic or oleophobic moieties; wherein said applying comprises spray coating of said second particles using a stream of gas; and wherein said second particles comprise less than 2% by weight of a solvent.

[000143] Embodiment 28. The method of embodiment 27, wherein said composition comprising a binder further comprises first particles having a size of about 30 μm to about 225 μm .

[000144] Embodiment 29. The method of any of embodiments 27 to 28, wherein said gas is air, nitrogen, or CO_2 .

[000145] Embodiment 30. The method of any of embodiments 27 to 29, wherein said second particles contain less than about 5%, 4%, 3%, 2%, or 1% by weight of a volatile solvent as applied to the base coat.

[000146] Embodiment 31. The method of any of embodiments 27 to 30, wherein said second particles comprise a metalloid oxide.

[000147] Embodiment 32. The method of any of embodiments 27 to 31 wherein said particles are silica particles.

[000148] Embodiment 33. The method of any of embodiments 27 to 32, wherein said coating composition comprises second particles in a range selected from: about 0.1% to about 5%; about 0.2% to about 6%; about 4% to about 10%; about 6% to about 12%; about 8% to about 16%; about 1% to about 16%; about 1% to about 20%; about 10% to about 20% or about 15% to about 20% on a weight basis.

[000149] Embodiment 34. The method of any of embodiments 27 to 33, wherein said coating has a surface in contact with said substrate and an exposed surface not in contact with said substrate, and said coating has a greater amount of second particles on, at, or adjacent to the exposed surface than on at or adjacent to the surface in contact with the substrate.

[000150] Embodiment 35. The method of embodiment 34, wherein said surface in contact with said substrate has, no second particles.

[000151] Embodiment 36. The method of embodiment 34, wherein the number of second particles on said surface in contact with said substrate is less than about 1%, about 2%, about 5%, about 10%, about 20%, about 30%, about 40%, about 50%, about 60%, about 70%, about 80%, or about 90% of the number of second particles on at or adjacent to said exposed surface.

[000152] Embodiment 37. The method of any of embodiments 27 to 36, wherein the binder comprises a polyurethane, lacquer, fluoropolymer, or epoxy.

[000153] Embodiment 38. The method of any of embodiments 28 to 37, wherein the binder is hydrophilic or hydrophobic in the absence of said first particles and said second particles.

[000154] Embodiment 39. The method of any of embodiments 28 to 38, wherein said first particles comprise a material selected from the group consisting of: wood, cellulose, glass, metal oxides, metalloid oxides (*e.g.*, silica), plastics, carbides, nitrides, borides, spinels, diamond, fly ash, hollow glass spheres, and fibers.

[000155] Embodiment 40. The method of any of embodiments 28 to 39, wherein the first particles have an average size in a range selected from: greater than about 5 μm to about 50 μm ; about 10 μm to about 100 μm ; about 10 μm to about 200 μm ; about 20 μm to about 200 μm ; about 30 μm to about 100 μm ; about 30 μm to about 200 μm ; about 50 μm to about 100 μm ; about 50 μm to about 200 μm ; about 75 μm to about 150 μm ; about 75 μm to about 200 μm ; about 100 μm to about 225 μm ; about 125 μm to about 225 μm ; and about 100 μm to about 250 μm .

[000156] Embodiment 41. The method of any of embodiments 28 to 40, wherein the first particles have an average size greater than 30 μm and less than 250 μm .

[000157] Embodiment 42. The method of any of embodiments 38 to 41, wherein the first particles have a size of 30 μm or greater in at least one dimension.

[000158] Embodiment 43. The method of any of embodiments 28 to 42, wherein said first particles do not comprise one or more independently selected hydrophobic and/or oleophobic moieties covalently bound to said first particle, or any hydrophobic or oleophobic moieties associated with said first particles as applied to (*e.g.*, mixed with) said binder.

[000159] Embodiment 44. The method of any of embodiments 28 to 43, wherein said first particles comprises one or more independently selected hydrophobic and/or oleophobic moieties covalently bound to said first particle.

[000160] Embodiment 45. The method of any of embodiments 28 to 44, wherein said one or more hydrophobic and/or oleophobic moieties comprise one or more independently selected alkyl, fluoroalkyl or perfluoroalkyl moieties.

[000161] Embodiment 46. The method of any of embodiments 27 to 45, wherein said first particles and/or second particles comprise one or more covalently bound hydrophobic or oleophobic moieties of the form:

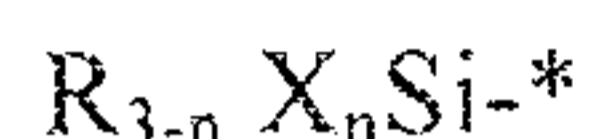

where n is an integer from 0 to 2;

each R is independently selected from

- (i) alkyl or cycloalkyl group optionally substituted one or more fluorine atoms,
- (ii) C_{1 to 20} alkyl optionally substituted with one or more independently selected substituents selected from fluorine atoms and C_{6 to 14} aryl groups, which aryl groups are optionally substituted with one or more independently selected halo, C_{1 to 10} alkyl, C_{1 to 10} haloalkyl, C_{1 to 10} alkoxy, or C_{1 to 10} haloalkoxy substituents,
- (iii) C_{6 to 20} alkyl ether optionally substituted with one or more substituents independently selected from fluorine and C_{6 to 14} aryl groups, which aryl groups are optionally substituted with one or more independently selected halo, C_{1 to 10} alkyl, C_{1 to 10} haloalkyl, C_{1 to 10} alkoxy, or C_{1 to 10} haloalkoxy substituents,
- (iv) C_{6 to 14} aryl, optionally substituted with one or more substituents independently selected from halo or alkoxy, and haloalkoxy substituents;
- (v) C_{4 to 20} alkenyl or C_{4 to 20} alkynyl, optionally substituted with one or more substituents independently selected from halo, alkoxy, or haloalkoxy;
- (vi) -Z to ((CF₂)_q(CF₃))_r, wherein Z is a C_{1 to 12} divalent alkane radical or a C_{2 to 12} divalent alkene or alkyne radical, q is an integer from 1 to 12, and r is an integer from 1 to 4);

each X is independently selected from -H, -Cl, -I, -Br, -OH, -OR², -NHR³, and -N(R³)₂;

each R² is independently selected from C_{1 to 4} alkyl and haloalkyl; and

each R³ is independently an independently selected from H, C_{1 to 4} alkyl and haloalkyl; where the open bond indicated by the * indicates a point of attachment to a particle.

[000162] Embodiment 47. The method of embodiment 46, wherein R is selected from: (a) an alkyl or fluoroalkyl group having from 6 to 20 carbon atoms; (b) an alkyl or fluoroalkyl group having from 8 to 20 carbon atoms; (c) an alkyl or fluoroalkyl group having from 10 to 20 carbon atoms; (d) an alkyl or fluoroalkyl group having from 6 to 20 carbon atoms when n is 3; (e) an alkyl or fluoroalkyl group having from 8 to 20 carbon atoms when n is 3; and (f) an alkyl or fluoroalkyl group having from 10 to 20 carbon atoms when n is 3.

[000163] Embodiment 48. The method of any of embodiments 46 to 47, wherein R is $-Z-$
 $((CF_2)_q(CF_3))_r$.

[000164] Embodiment 49, The method of any of embodiments 46 to 48, wherein all halogen atoms present in any one or more R groups are fluorine atoms.

[000165] Embodiment 50. The method of any of embodiments 27 to 45, wherein said second particles are prepared by treating a particle having a size of about 1 nm to 25 μ m with a silanizing agent selected from: tridecafluoro-1,1,2,2-tetrahydrooctyl)silane (SIT8173.0); (tridecafluoro-1,1,2,2-tetrahydrooctyl) trichlorosilane (SIT8174.0); (tridecafluoro-1,1,2,2-tetrahydrooctyl)triethoxysilane (SIT8175.0); (tridecafluoro-1,1,2,2-tetrahydrooctyl)trimethoxysilane (SIT8176.0); (heptadecafluoro-1,1,2,2-tetrahydrodecyl)dimethyl(dimethylamino)silane (SIH5840.5); (heptadecafluoro-1,1,2,2-tetrahydrodecyl)tris(dimethylamino)silane (SIH5841.7); n-octadecyltrimethoxysilane (SIO6645.0); n-octyltriethoxysilane (SIO6715.0); and nonafluorohexyldimethyl(dimethylamino)silane (SIN6597.4).

[000166] Embodiment 51. The method of any of embodiments 27 to 45, wherein said second particles are particle having a size of about 1 nm to 25 μ m (*e.g.*, silica particles) treated with a silanizing agent selected from: dimethyldichlorosilane, hexamethyldisilazane, octyltrimethoxysilane, polydimethylsiloxane, or tridecafluoro-1,1,2,2-tetrahydrooctyl trichlorosilane.

[000167] Embodiment 52. The method of any of embodiments 27 to 45, wherein said second particles are silica particles prepared by treating said silica particles with an agent that will increase the number of sites on the silica particles that can react with a silanizing agent prior to being treated with said silanizing agent.

[000168] Embodiment 53. The method of embodiment 52, wherein said agent that will increase the number of sites on the silica particles that can react with silanizing agents is selected from the group consisting of: $SiCl_4$, $SiCl_4$, $Si(OMe)_4$, $Si(OEt)_4$, $SiCl_3CH_3$, $SiCl_3CH_2SiCl_3$, $SiCl_3CH_2CH_2SiCl_3$, $Si(OMe)_3CH_2Si(OMe)_3$, $Si(OMe)_3CH_2CH_2Si(OMe)_3$, $Si(OEt)_3CH_2Si(OEt)_3$, or $Si(OEt)_3CH_2CH_2Si(OEt)_3$.

[000169] Embodiment 54. The method of any of embodiments 27 to 53, wherein second particles have an average size in a range selected from about 1 nm to about 100 nm; about 10 nm to about 200 nm; about 20 nm to about 400 nm; about 10 nm to 500 nm; about 40 nm to about 800 nm; about 100 nm to about 1 micron; about 200 nm to about 1.5 micron; about 500 nm to about 2 micron; about 500 nm to about 2.5 μ m; about 1.0 micron to about 10 μ m; about 2.0 micron to about 20 μ m; about 2.5 micron to about 25 μ m; about 500 nm to about 25 μ m; about 400 nm to about 20 μ m; and about 100nm to about 15 μ m.

[000170] Embodiment 55. The method of any of embodiments 27 to 54, wherein said second particles comprise: a metal oxide, an oxide of a metalloid, a silicate, or a glass.

[000171] Embodiment 56. The method of any of embodiments 27 to 55, wherein said second particles are comprised of silica and have an average size in a range selected from about 1 nm to about 50 nm; about 1 nm to about 100 nm; about 1 nm to about 400 nm; about 1 nm to about 500 nm; about 2 nm

to about 120 nm; about 5 nm to about 150 nm; about 5 nm to about 400 nm; about 10 nm to about 300 nm; and about 20 nm to 400 nm.

[000172] Embodiment 57. The method of embodiment 56, wherein said second particles have an average size in the range of about 1 nm to about 100 nm or about 2 nm to about 200 nm.

[000173] Embodiment 58. The method of any of embodiments 27 to 57, further comprising treating said coating with a silanizing agent such as a compound of formula I.

[000174] Embodiment 59. The method of embodiment 58, wherein said silanizing agent is selected from the group consisting of (tridecafluoro-1,1,2,2-tetrahydrooctyl)silane (SIT8173.0); (tridecafluoro-1,1,2,2-tetrahydrooctyl) trichlorosilane (SIT8174.0); (tridecafluoro-1,1,2,2-tetrahydrooctyl)triethoxysilane (SIT8175.0); (tridecafluoro-1,1,2,2-tetrahydrooctyl)trimethoxysilane (SIT8176.0); (heptadecafluoro-1,1,2,2-tetrahydrodecyl)dimethyl(dimethylamino)silane (SIH5840.5); (heptadecafluoro-1,1,2,2-tetrahydrodecyl)tris(dimethylamino)silane (SIH5841.7); n-octadecyltrimethoxysilane (SIO6645.0); n-octyltriethoxysilane (SIO6715.0); and nonafluorohexyldimethyl(dimethylamino)silane (SIN6597.4).

[000175] Embodiment 60. An article having a surface coated with a hydrophobic coating prepared by the method of embodiments 27-59.

[000176] Embodiment 61. The article of embodiment 60, wherein said article is a plunger.

[000177] Embodiment 62. A plunger for clearing clogged plumbing having a hydrophobic coating on at least a portion of its surface, that when removed from sewage waste water is substantially free of any adhering water or drips and free of any solid or semi-solid particle(s) attached to the portion of the plunger coated with a hydrophobic coating (*e.g.*, the plunger has less than about 0.1, 0.2, 0.4, 0.5, 0.7, 1, 2, 3, or 5 grams of material adhering to the surface to the plunger).

[000178] Embodiment 63. The article of embodiment 60, or the plunger of embodiments 61 or 62, wherein the coating is resistant to bacterial growth.

[000179] Embodiment 64. The method of any of embodiments 27 to 59 or the article of any of embodiments 60 to 63, wherein the coating has an arithmetical roughness value from about 0.4 to about 5.6 μm or a ten point mean roughness from about 0.8 to about 5.8 μm .

[000180] Embodiment 65. The method of any of embodiments 27 to 59 or the article of any of embodiments 60 to 64, wherein the coating is resistant to greater than 20, 30, 40, 40, 60, 70, 80, 90, 100, 200, or 250 abrasion cycles on Taber Model: 503 instrument using CS-10 wheels with 250 g load (*e.g.*, tested as applied to a metal, such as aluminum, plate).

[000181] Embodiment 66. The plunger of embodiment 1, wherein said hydrophobic coating comprises:

i) a binder; and

ii) second particles having a size of about 1 nm to 25 μm comprising one or more independently selected hydrophobic or oleophobic moieties; wherein said composition optionally contains 5% to 10% of a block copolymer on a weight basis.

[000182] Embodiment 67. The plunger of any of embodiments 1 or 66, wherein said hydrophobic coating comprises a base coat comprised of said binder (without added first particles) applied to said cup and optionally applied to said handle, and a top coat applied to said base coat comprised of said second particles.

[000183] Embodiments also include one-step and two-step compositions for use in forming hydrophobic and/or oleophobic compositions. Those compositions may be in the form kits that include the coating component(s) and instructions for their use.

8.0 EXAMPLES

Example 1. High and Low Volatile Organic Compound (VOC) Coating processes Two-Step Coating Processes

Process A: Two-Step High VOC Process

[000184] This process consists of two steps each applying coatings via wet spray technique. In the first step a first or base coat is prepared comprising POLANE® B system from Sherwin Williams is formulated to a 6:3:1 volume ratio of POLANE® B, POLANE® Reducer and POLANE® A Catalyst as follows:

The first coat is prepared using a polyurethane binder, prepared as follows:

POLANE® B (F63W13)	6 parts	(strobe white, F63W13, Sherwin Williams, PA)
Catalyst (V66V29)	1 part	
Reducer (R7K84)	3 parts	
POLANE® accelerator (V66VB11)	0.1%	

[000185] All ingredients are mixed by weight. The accelerator is used to speed the POLANE® curing process.

[000186] To the composition comprising the binder used in the first coat (base coat) a variety of different first particles can be added to enhance the durability and/or the bonding of the top coat to the base coat. First particles, some times referred to as fillers herein, include, but are not limited to glass bubbles (*e.g.*, 3M® glass bubbles, which are hollow glass microspheres of soda-lime-borosilicate glass). Some glass bubbles suitable for use in the present coatings include: S60, K20, and K25 glass bubbles, whose particle sizes are given in Table 1.1.

[000187] The first coat is applied to the article, and after about 60 to 120 seconds the second or top coat is applied. The second step comprises spraying a hexane slurry (4% w/v) of a hydrophobic second particles (*e.g.*, treated fumed silica).

[000188] The base coat composition, without the first particles, contains about 30% solids, and releases about 7 grams of VOCs per 10 grams of wet coating, which is about the amount applied to some plungers described in later examples. Additionally the second step in the process, which utilizes a hexane mixture with fumed silica releases about 13 grams of VOCs per 25ml applied to an article the size (surface area to be coated) of a plunger. This process therefore releases a total of about 20 grams of VOCs for per article the size of a plunger.

Process B: Two-Step Low VOC Process

[000189] This process consists of two steps the first comprising a wet application of a first or base coat) followed by an application of a second coating composition using materials that are not considered VOCs such as a stream of compressed air. In the first step a first coat (base coat) is prepared comprising a water borne polyurethane dispersion based on Bayer Material Science product Bayhydrol 124 and Sherwin Williams POLANE® 700T. That coating composition comprises about 35% solids and contains about 53% water and 12% *n*-methyl-2-pyrrolidone by weight. A 5%w/w loading of first particles (*e.g.*, glass microspheres) is employed. The weight of glass microspheres used is determined based upon the weight of the coating composition as prepared.

[000190] To the composition comprising the binder used in the first coat a variety of different first particles can be added to enhance the durability and/or the bonding of the top coat to the base coat. First particles, some times referred to as fillers herein, include, but are not limited to glass bubbles (*e.g.*, 3M® glass bubbles, which are hollow glass microspheres of soda-lime-borosilicate glass). Some glass bubbles suitable for use in the present coatings include: S60, K20, and K25 glass bubbles, whose particle sizes are given in Table 1.1.

[000191] The first coat is applied to the article, and after about 60 to 120 seconds the second or top coat is applied. The second step comprises applying an alcohol or acetone slurry (4% w/v) of hydrophobic second particles (*e.g.*, treated fumed silica) on to the first coat by spraying or dipping. Alternatively, a hydrophobic fumed silica can be applied to the surface using a stream of compressed gas typically at about 10 to 100 psi in the absence of VOCs.

[000192] The coating process would release about 1.2 grams of VOC per article about the size of a plunger in the first step and 7 grams in the second step, bringing the total down to 8.2 g per article the size of a plunger if solvent is used in the second step and 1.2 g if no solvent is used in the second step.

Example 2. A Two-Step Hydrophobic Coating Process as Applied to Plunger for Drains

[000193] Although the methods described herein can be applied to any suitable surface, this example uses the two step coating process to apply a hydrophobic coating to a plunger for clearing drains.

Surface Preparation

[000194] In order to obtain tight adhesion of the base coat to the a surface, such as the cup and handle parts of a plunger, the surface roughness is increased by methods including: (1) scuffing with a Scotch Brite™ pad, (2) fine sandblasting, (3) tumble blasting with small steel balls, and (4) coarse sandblasting. The roughness can be expressed using a variety of mathematical expressions including, but not limited to, the Arithmetical Mean Roughness (Ra) and Ten-Point Mean Roughness (Rz), which are described in Scheme II. Values for Ra and Rz surface roughness produced by different methods compared with the starting surface roughness, (measured using a Mahr Pocket Surf PS1 by Mahr Federal Inc., Providence, RI) are given in Table 2.1.

Table 2.1: Plunger Roughness Produced by Different Methods

	Ra (μm)	Rz (μm)		Ra (μm)	Rz (μm)
Starting Handle	0.222	1.160	Starting Cup	0.315	2.490
	0.205	2.140		0.353	2.510
	0.246	1.400		0.242	1.730
Average	0.224	1.567		0.204	1.440
Scotch Brite Scuffed Handle	0.804	5.77	Average	0.279	2.043
	0.846	6.19	Scotch Brite Scuffed Cup	0.378	3.85
	0.99	6.88		0.51	3.99
Average	0.88	6.28		0.506	2.91
Coarse Sandblast Handle	5.921	34.300		0.37	3.41
	5.175	32.100	Average	0.441	3.54
	5.844	31.600	Fine Sandblast Cup	0.757	7.32
	5.708	34.200		0.578	4.61
Average	5.662	33.050		0.686	5.51
				0.716	7.34
				0.638	6.3
			Average	0.675	6.216
			Tumble Blaster Cup (Small Steel Balls)	0.429	4.81
				0.407	2.88
				0.459	4.32
				0.434	4.92
			Average	0.387	3.28
			Coarse Sandblast Cup	4.118	25.000
				5.243	35.300
				6.619	39.900
				6.052	32.400
			Average	5.508	33.150

Coating process

[000195] The conversion of plunger parts (cup and handle) into hydrophobic surfaces is accomplished by application of surface coating using a two-step process. In the two-step process the first coat (base coat) generally serves as a base or binder coat to the substrate (cup and handle of the plunger in this case) and the second coat (top coat) comprises hydrophobic second particles (hydrophobic fumed silica).

[000196] The first coat (base coat) is prepared using a polyurethane binder, prepared as follows from the following ingredients by weight:

POLANE® B (F63W13) 6 parts (strobe white, F63W13, Sherwin Williams, PA)
Catalyst (V66V29) 1 part

Reducer (R7K84) 3 parts
POLANE® accelerator (V66VB11) 0.1%

[000197] All ingredients are mixed. The accelerator is used to speed the POLANE® curing process.

[000198] A variety of different first particles can be added to enhance the durability of bonding of the top coat to the base coat. First particles, some times referred to as fillers herein, include, but are not limited to glass bubbles (e.g., 3M® glass bubbles, which are hollow glass microspheres of soda-lime-borosilicate glass). Some glass bubbles suitable for use in the present coatings include: S60, K20, and K25 glass bubbles, whose particle sizes are given in Table 2.2.

Table 2.2: Particle Size Distribution of 3M™ Glass Bubbles

Product	Particle Size (Microns, by Volume) 3M QCM 193.0			Effective Top
	Distribution			
	10 th %	50 th %	90 th %	
S60	15	30	55	65
K25	25	55	90	105
K20	20	60	90	105

[000199] The top coat comprises nano-sized (5-50 nm) fumed silica particles, which are pretreated with chemical moieties that impart hydrophobicity (e.g., a silazane or a siloxane). In one top coat of this example TS-720 (Cabot Corporation, Billerica, MA) is employed. In another top coat of this example R812S (Evonik Degussa Corp., Parsippany, NJ) is employed.

Table 2.3: Properties of TS-720 and R812S Silicas

Silica Grade	Source	Surface Treatment	Nominal BET Surface Area (m ² /g)
TS-720	Cabot	Polydimethylsiloxane	200
R812S	Evonik	Hexamethyldisilazane	220

[000200] Both TS-720 and R812S are fumed silica of approximately the same surface area. However, they are treated with two different compounds whose molecular formulas are shown below.

Polydimethylsiloxane

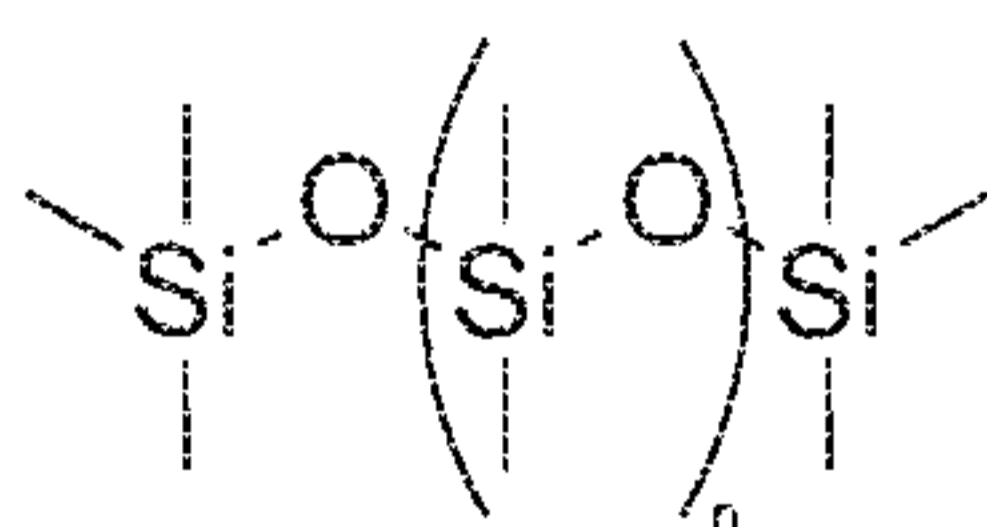

Hexamethyldisilazane

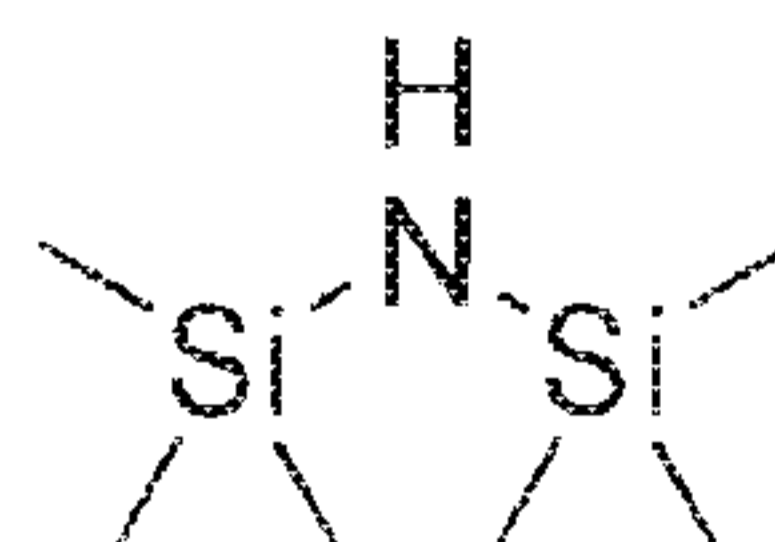

In this example the top coats is applied by one of two methods:

[000201] Method 1: In this method, fumed silica particles are dispersed in a solvent (e.g., hexane) and sprayed. Typical dispersions obtained with TS-720 are prepared with 4 g of TS-720 in 100 ml of hexane. For R812S, the dispersion is employed uses 8 g of R812S in 100 ml of hexane. The fumed silica dispersion is sprayed onto the base coat using an air spray gun Binks Model 2001 or 2001V spray gun air spray gun.

[000202] Method 2: The fumed silica is delivered to the surface of the base coat without hexane. The fumed silica is sprayed on at a high air pressure (20 - 100 psi) onto the base coat. The pressure of spray is critical to get good bond with the base coat (Binks Model 2001 or 2001 V spray gun air spray gun).

[000203] In method 2 excess fumed silica is recovered by a dust collection system from the spray booth and can be reused.

Sample 1: Plunger Prepared With Two-Step Coating Using a Base Coat (Containing no first particles)

[000204] A plunger cup and a part of the handle adjacent to the cup (part most likely to contact water/sewage) are coated with the above-described strobe white POLANE™ containing base coat. A total of 10 g of the POLANE™ containing base coat is applied by spraying the inside and outside of the cup and part of the handle. The base-coated cup and handle are subsequently coated with a second (top) coat of 20 ml of composition comprising 4 g of TS-720 fumed silica suspended in 100 ml of hexane within 30 min after spraying the base coat to maximize the bonding of the fumed silica top coat to the base coat.

[000205] The coated plunger is cured at room temperature for 24 hours. After curing, the plunger is tested by inserting it in the toilet water. After 50 plunges, some water droplets remain on the edge of the top plunger and on the bottom side of the rim.

Sample 2: Two-Step Coating Employing Glass Bubble Second Particles (10% - 15% S60 Particles)

[000206] A plunger is coated using the process described for Sample 1, except that the base coating of POLANE® contains 10% - 15% (by weight) of S60 glass bubbles (see Table 1 for details). Quantities of the base and top coats are kept nearly the same. After curing, the plunger is tested in a toilet by repeated plunges. After about 100 plunges, some water droplets were seen on the bottom rim (7) and lip (8) of the cup. No droplets were seen on the edge of the top of the plunger as was the case in Example 1. The incorporation of S60 particles in the base coat approximately doubles the number of plunges with minimum droplet adherence at limited locations.

Sample 3: Base Coat with 5% K25 Glass Bubbles as Filler

[000207] A plunger is coated using the process described for Sample 1, except that the base coating of POLANE® contains 5% of the K25 glass bubbles (see Table 1 for details) as first particles. After applying the top coat and curing at room temperature for 24 hours, the plunger is tested in a toilet. After about 100 plunges only one or two droplets are seen on the inside of the cup near the rim and lip.

Sample 4: Base Coat with 10-15% K25 Glass Bubbles

[000208] A plunger is coated using the process described for Sample 1, except that the base coating of POLANE® contains 10-15% K25. After curing at room temperature for 24 hours the plunger is tested by plunging 100 times in a toilet. This plunger, which has a slightly rougher surface than plunger in Sample 3, shows no sticking of any water droplets in any location (outside or inside the cup).

Sample 5: Base Coat with 5% K20 Glass Bubbles and Top Coat using R8125-Treated Silica

[000209] A plunger is coated using the process described for Sample 1, except that the base coating of POLANE® contains K20 glass bubbles (5%) to limit the coating roughness. After applying the base coat by spraying, the top coat, which is prepared by suspending 8 g of R812S-treated fumed silica (Evonik Industries) in 50 ml of hexane is applied. Although the same quantity of top coat is used as in Sample 1, it contains only half the amount of hexane. After curing at room temperature for 24 hours, the plunger is tested by plunging a toilet 250 times, after which no water droplets are noted on any of the surfaces. In addition, even following 250 plunges no indication of any cracking or flaking of the coating is noted.

Sample 6: Base Coat with 5% K20 Glass Bubbles as Filler and Pressure Applied Dry Top Coat of TS-720

[000210] A plunger is coated with a base coating of POLANE® containing 5% K20 glass bubbles, as in Sample 5. A top coat of TS-720 fumed silica is applied within 10 minutes by high pressure (50 psi) spraying using a Binks Model 2001 or 2001V spray gun air spray gun air in an enclosed box with dust collection system. After curing at room temperature for 24 hours, the plunger is tested by plunging in a toilet 300 times, without the adherence of any water droplets.

Sample 7: Base Coat with 5% K20 Glass Bubble Filler and Pressure Applied Dry Top Coat of R812S

[000211] A plunger is coated with a base coating of POLANE® containing 5% K20 glass bubbles, as in Sample 6. However, the top coat of TS-720 applied by pressure spraying is replaced by a coating of R812S fumed silica applied using the same air pressure (50 psi). After curing at room temperature for 24 hours, the plunger is tested in a toilet by plunging 250 times without the adherence of any water droplets.

Example 3 Plunger Base and Coating and Top Coating Procedure:

[000212] A base coat is prepared using POLANE® System and glass bubbles:

POLANE® B = 6 parts (Sherwin Williams (521-1404), Strobe White, F63W13)
 POLANE® A Exterior Catalyst = 1 part (Sherwin Williams (500-1417), V66V29)
 POLANE® Reducer = 3 parts (Sherwin Williams (530-2641), R7K69)
 K20 Glass Bubbles = 5.0% by weight to POLANE® mix (3M®, 70-0704-8403-8)

[000213] To a plastic mixing container whose empty weight is determined is added POLANE® B (6 parts), POLANE® A (1 part) and POLANE® Reducer (3 parts) by volume. Hazardous Air Pollutants (HAPS) free POLANE® Reducer (R7K95) can be used in place of POLANE® Reducer (R7K96). The mixture is stirred for 3 minutes using a mechanical mixer/drill with mixing blade. The container and its contents are weighed and the weight of the POLANE® components determined by deducting the empty weight of the container. K20 glass bubbles are added (5% by weight) and the mixture is stirred for 5 minutes to ensure complete mixing of K20 glass bubbles into the liquid components to form a K20/POLANE® base coat composition. The approximate pot-life of the base coat composition is 4-6 hours.

[000214] Plungers are prepared for the application of the base coat by Scuffing of handle and plunger head using an abrasive pad (e.g. Scotchbright pads), fine sandblast, and/or tumble blasting with

aluminum oxide or steel ball bearings. The plunger is cleaned of debris from the scuffing process, for example using high pressure air or water followed by drying.

[000215] The K20/POLANE® base coat composition is poured into a gravity fed spray gun (Central Pneumatic, 20 oz. (50-70 psi), Item #47016) and sprayed on to the plunger head and at least the portion of the handle closest to the plunger head (*e.g.*, about 6 inches of the handle) (approximately 15-20mL of K20/ POLANE® mixture per plunger is sprayed in the process. Including over spray, the coating amounts to about 3.0g of dried coating mixture. The thickness will depend upon the amount of material sprayed and the amount of overspray. Care must be taken to ensure complete coverage of all portions of the plunger cup, such as the inside of the cup and underneath parts of the rim/lip.

[000216] Top coats, such as those comprising silica and a hydrophobic moiety (*e.g.*, a bound silane group) can be applied to the base coat after a period of about 60 to 120 seconds. The application of the top coat may be conducted by spraying the base coat with top coat composition comprising second particles using a stream of gas (*e.g.* air) in the presence or absence of a compatible solvent. Alternatively, the top coat may be applied by dipping a plunger into a coating composition comprising secondary particles.

Example 4 Abrasion Testing of Coatings

[000217] To assess the abrasion resistance of the hydrophobic coatings, and particularly the abrasion resistance of coatings that can be applied to flexible materials such as the cup of a plunger, a first coat binder composition as described in Example 2 including the indicated filler is applied to 4 inch by 4 inch aluminum plates. One of four different fillers (S60, K20, 512 Black or K25 Black) is added to the coating composition applied to each plate. Following the application of the first coat, second coats are applied to the plates using compressed air at the indicated pressures to apply TS720 silica or R812S silica (see the columns marked "Dry Power Spraying") in the accompanying table. Control aluminum plates, where the second coat is applied by spraying them with a slurry comprising TS720 or R812S hydrophobic fumed silica (4g/100ml w/v) in hexane, are also prepared.

[000218] After air drying at room temperature for 24 hours the plates were subject abrasion testing. Although resistance to abrasion may be measured using any method known in the art, for the purpose of this application abrasion testing was conducted using a Taber Model: 503 instrument equipped with CS-10 wheels with loads as indicated.

ABRASION TESTING TABLE

<i>Dry Powder Spraying (TS720)</i>		<i>Dry Powder Spraying (R812S)</i>		<i>Hexane Spraying (TS720)</i>	
<u>S60 Glass (10-15%)</u>				<i>Filler</i>	<i>Taber Cycles (250g load)</i>
Spray Pressure	Taber Cycles (250g load)	Spray Pressure	Taber Cycles (250g load)		
10 psi	20 cycles	10 psi	20 cycles	S60 Glass (10-15%)	200
20 psi	40 cycles	20 psi	40 cycles	K20 Glass (5%)	350
30 psi	80 cycles	30 psi	70 cycles	K25 Glass (5%)	450
40 psi	100 cycles	40 psi	105 cycles	512 White or Black (10-15%)	400
<u>Filler K20 Glass (5%)</u>				<u>Hexane Spraying POLANE® White/R812S</u>	
Spray Pressure	Taber Cycles (250g load)	Spray Pressure	Taber Cycles (250g load)	<i>Filler</i>	<i>Taber Cycles (250g load)</i>
10 psi	20 cycles	10 psi	20 cycles	S60 Glass (10-15%)	180-220
20 psi	30 cycles	20 psi	40 cycles	K20 Glass (5%)	400
30 psi	50 cycles	30 psi	65 cycles	K25 Glass (5%)	400
40 psi	85 cycles	40 psi	90 cycles	512 White or Black (10-15%)	375-425
<u>K25 Black (10-15%)</u>					
Spray Pressure	Taber Cycles (250g load)	Spray Pressure	Taber Cycles (250g load)		
10 psi	20 cycles	10 psi	15 cycles		
20 psi	30 cycles	20 psi	30 cycles		
30 psi	60 cycles	30 psi	55 cycles		
40 psi	80 cycles	40 psi	80 cycles		
<u>512 Black (10-15%)</u>					
Spray Pressure	Taber Cycles (250g load)	Spray Pressure	Taber Cycles (250g load)		
10 psi	125 cycles	10 psi	125 cycles		
20 psi	150 cycles	20 psi	150 cycles		
30 psi	200 cycles	30 psi	200 cycles		
40 psi	200 cycles	40 psi	200 cycles		

Example 5 One-Step Coating Process Employing Water-Based Polyurethanes

[000219] A 40-g quantity of 40:60 ratio by volume of POLANE® 700T (Sherwin-Williams Co., Cleveland, OH) and Bayhydrol 124 (Bayer Material Science, Pittsburg, PA) is prepared as a binder composition. Both 700T and Bayhydrol 124 are water-based polyurethanes. POLANE® 700T comes with pigment preloaded, whereas Bayhydrol 124 is provided from the manufacturer as an un-pigmented coating composition to which pigment can be added at will. A 40:60 blend of POLANE® 700T to Bayhydrol 124 achieves a desirable pigment content. Optional components such as silver nanoparticles (10-30 ppm) may be added to the coating composition to provide antimicrobial action.

[000220] To the 40-g mixture of POLANE® and Bayhydrol described above, 2 g of S60, glass spheres (first particles), 4.5 g of TS-720 (second particles of fumed silica treated with polydimethylsiloxane), and 15 g of water is added. The components are mixed extensively to achieve a good dispersion of TS-720 in the polyurethane binder composition and to form a one-step coating composition. The one-step-coating composition can be applied to surfaces by any suitable means including, but not limited to, spraying for several hours provided it is periodically mixed.

[000221] There are several advantages to the use of one-step processes, including one step process that employ water based binder systems to prepare hydrophobic and/or oleophobic coatings. One advantage is a minimization of the time that is needed to coat objects. Another advantage of the process described in this example is that it releases very low amounts of VOCs because essentially no solvents are used. Any VOCs released are associated with the water-based binder components (POLANE® 700T and/or Bayhydrol 124).

[000222] To prepare hydrophobic and/or oleophobic coated objects (e.g., plungers), the composition comprising binder, first, and second particles is sprayed on to the desired portions of the object after surface preparation (e.g., the plunger cup and part of the handle after roughening and cleaning) such as by using an air spray gun. The coating is left to dry for a suitable period depending on local conditions such as temperature and humidity (generally about 3 to 4 hours for water based polyurethane compositions).

[000223] Two plungers treated by coating the plunger cup and a portion of the handle with the one-step Polane 700T --Bayhydrol composition described in this example are dried for 3-4 hours and tested. The coated plungers are tested by repeated plunging of a toilet. Each of the two plungers showed no water droplet sticking to any coated part of the plunger even after 500 plunges. The process yields hydrophobic and/or oleophobic coatings that are comparable in their ability to shed water to coatings that have been prepared by two step processes (e.g., the amount of water retained by the coating does not significantly increase even after repeated use such as in plunging tests).

Example 6 Two-Step Coating Process Employing Water-Based Polyurethanes

[000224] A mixture comprising a 40:60 ratio of POLANE® 700T and Bayhydrol 124 by volume is prepared. To that mixture water (7% by weight), K20 glass beads (5% by weight) and untreated M5 fumed silica (2.5% by weight) is added to form a base coating composition (i.e., to 100g of the

POLANE® /Bayhdrol mixture 7 g of water, 5 g of glass beads, and 2.5g of silica is added). The mixture is stirred and applied to prepared surfaces to form a base coat. After its application, the base coat is allowed to dry for a suitable period of time and a second coating (a 4% w/v mixture of TS-720 in acetone) is applied by for example by dipping. After application of the second coating composition, the two-step coating can be given a subsequent treatment, for example with the second coating if desired or needed to produce a suitably hydrophobic and/or oleophobic surface. Optional components such as silver nanoparticles (10-30 ppm) may be added to the coating composition to provide antimicrobial action.

[000225] Four plungers are prepared for treatment using the two step process described above. Three of the plungers are prepared for coating by sandblasting and a fourth plunger is prepared by tumble blasting. Residue from the blasting step is removed by washing, and the plungers and drying them prior to any subsequent treatment. Each of the four plungers is sprayed with the above-described base coating composition. After the base coat, the three sand blasted plungers are left to dry for 45, 60, and 75 minutes, respectively; the tumble blast plunger is dried for about 70 minutes. After the specified drying time, the plunger is dipped into a second coating composition of 4% w/v mixture of TS-720 silica in acetone. After dipping, each plunger was allowed to dry and then given 3 to 5 minutes in acetone, after which it was sprayed with the same second coating composition in critical areas such as at the base of the cup and areas around the cup and both inside and outside the cup. The plungers are left to cure for two days prior to testing. The following test results are noted for each of the plungers:

[000226] Plunger #1 (Sandblast, 45 minutes drying time before dipping in second coating): With the treatment used to apply the coating to this plunger, some tiny water droplets attach to the inside of the cup at points where cracking was observed after subjecting the plunger to testing. The cracking is apparently caused by the excess application of TS-720 during the dip application step. The first tiny droplets were observed to adhere to the plunger after about 50 plunges. Besides the adherence of droplets to that local area no other droplets were observed adhering to any other part of the plunger for 400 plunges.

[000227] Plunger #2 (Sandblast, 60 minutes drying time before dipping in second coating): The base coat applied to this plunger is drier than the base coat applied to plunger #1 at the time the second coating is applied by dipping. The cup still acquired excess TS-720 in small areas during the dipping process. With this plunger, the tiny droplets stick to the inside of the cup, but only after 100 plunges. Aside from this local effect, the plunger shows no additional droplets adhering to its surface for 400 plunges, at which point the testing stopped.

[000228] Plunger #3 (Sandblast, 75 minutes drying time before dipping in second coating): The drying time for this plunger permitted a more uniform coating with the second coating composition in the dipping process. As dipping the base coated plunger into the TS-720/acetone mixture does not cause any excess build-up in any areas of the plunger no cracking or water droplet adherence is observed. No water droplets are observed adhering to the inside of the cup, or elsewhere, even after 400 plunges, as compared to plungers #1 and #2.

WO 2011/116005**PCT/US2011/028541**

[000229] Plunger #4 (Tumble blast, 70 minutes drying time before dip): This plunger, performs in a manner similar to plunger #3, and does not show any excess pick-up of TS-720 during the dip process. The plunger can be subject to 400 plunges without any droplets sticking to the cup.

[000230] As with the one-stop process using water-based polyurethanes described in Example 5, this two-step process advantageously limits the amount of VOCs released in the coating process (acetone is VOC exempt). For coatings applied after a drying time of about 60 to 70 minutes (for plungers), the plungers performed about as well as those prepared using the one step process regardless of the pretreatment of the surface (e.g., sandblasting or tumble blasting).

Claims

1. A plunger for clearing clogged plumbing, having a handle and a resilient collapsible cup comprising an outer surface and an inner surface, said outer and inner surface meeting at a rim, and said handle attached to the outer surface, wherein said cup is coated with a hydrophobic coating, and wherein at least a portion of said handle is optionally coated with a hydrophobic coating.
2. The plunger of claim 1, wherein said hydrophobic coating comprises:
 - i) a binder; ii) first particles having a size of about 30 μm to about 225 μm ; and iii) second particles having a size of about 1 nm to about 25 μm comprising one or more independently selected hydrophobic or oleophobic moieties; wherein said composition optionally contains about 5% to about 10% of a block copolymer on a weight basis.
3. The plunger according to claim 2, wherein said hydrophobic coating comprises a base coat comprised of said binder and said first particles applied to said cup and optionally applied to said handle, and a top coat comprised of said second particles applied to said base coat.
4. The plunger of claims 2 or 3, wherein the outer surface of the cup is generally convex and said inner surface is generally concave, and wherein a cross section through the cup in a plane parallel to said rim is generally oval, elliptical, or oblate.
5. The plunger of any of claims 2-4, wherein said binder comprises polyurethane.
6. The plunger of any of claims 2-5, wherein said coating comprises about 5 to about 15% of first particles which are comprised of a material selected from: polymers, metals, glasses, glass bubbles, metalloid oxides, metal oxides, and cellulose.
7. The plunger of claim 6, wherein said second particles comprise silica particles and a silane, siloxane, silizane or a silane group of the form $\text{R}_{3-n}\text{Si-}$ where n is 0, 1 or 2.
8. The plunger of claim 7, wherein the silane, siloxane or silizane are selected from polydimethylsiloxane and hexamethyldisilazane.
9. The plunger of any of claims 4-8, wherein said hydrophobic coating is resistant to greater than 20, 40, 60, 80, 100, 120, 140, 160, 180, or 200 abrasion cycles on a Taber Model: 503 instrument using CS-10 wheels with 250 g load without the loss its hydrophobic properties.
10. The plunger of any of claims 1 to 9, wherein less than about 2 grams of water remain bound to the surface after immersion in water at about 20°C after the handle has been used to compress the cup 100 times.
11. The plunger of claim 10, wherein the coating further comprises silver particles.
12. The plunger of any of claims 1-11, wherein the handle comprises a hydrophobic coating.

13. The plunger of any of claims 1-12, wherein the hydrophobic coating is superhydrophobic.
14. A method of forming a hydrophobic coating on at least a portion of a surface comprising:
- i) applying a composition comprising a binder on said at least a portion of a surface, wherein said composition comprising a binder optionally includes first particles having a size of about 30 μm to about 225 μm ; and
 - ii) applying to said binder on said at least a portion of said surface second particles a having a size of about 1 nm to about 25 μm ;
- wherein said second particles comprising one or more independently selected hydrophobic and/or oleophobic moieties; and wherein said applying to said binder comprises spray coating of said second particles using a stream of gas; and wherein said second particles comprise less than 2% by weight of a solvent.
15. The method of claim 14, wherein said composition comprising a binder comprises first particles having a size of greater than about 30 μm in one dimension.
16. The method of claim 14 or 15 wherein said gas is air, nitrogen, CO_2 .
17. The method of any of claims 14 to 16, wherein said coating has a surface in contact with said substrate and an exposed surface not in contact with said substrate, and said coating has a greater amount of second particles on, at, or adjacent to the exposed surface than on, at, or adjacent to the surface in contact with the substrate.
18. The method of claim 17, wherein the binder comprises a polyurethane, lacquer, fluoropolymer, or epoxy.
19. The method of any of claims 14-18, wherein said first particles comprise a material selected from the group consisting of: wood, cellulose, glass, metal oxides, metalloid oxides, plastics, carbides, nitrides, borides, spinels, diamond, fly ash, hollow glass spheres, and fibers.
20. The method of any of claims 14-19, first particles have an average diameter greater than about 30 μm and less than about 225 μm .
21. The method of any of claims 14-20, wherein said first particles and/or said second particles comprise one or more independently selected hydrophobic and/or oleophobic moieties covalently bound to said first or second particles.
22. The method of claim 21, wherein said one or more hydrophobic and/or oleophobic moieties comprise one or more independently selected alkyl, fluoroalkyl or perfluoroalkyl moieties.

23. The method of claim 22, wherein said first particles and/or second particles comprise one or more covalently bound hydrophobic or oleophobic moieties of the form:

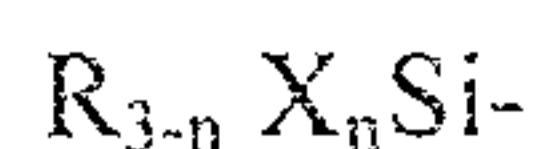

where n is an integer from 0 to 2;

each R is independently selected from

- (i) alkyl or cycloalkyl group optionally substituted with one or more fluorine atoms,
- (ii) C_{1 to 20} alkyl optionally substituted with one or more independently selected substituents selected from fluorine atoms and C_{6 to 14} aryl groups, which aryl groups are optionally substituted with one or more independently selected halo, C_{1 to 10} alkyl, C_{1 to 10} haloalkyl, C_{1 to 10} alkoxy, or C_{1 to 10} haloalkoxy substituents,
- (iii) C_{6 to 20} alkyl ether optionally substituted with one or more substituents independently selected from fluorine and C_{6 to 14} aryl groups, which aryl groups are optionally substituted with one or more independently selected halo, C_{1 to 10} alkyl, C_{1 to 10} haloalkyl, C_{1 to 10} alkoxy, or C_{1 to 10} haloalkoxy substituents,
- (iv) C_{6 to 14} aryl, optionally substituted with one or more substituents independently selected from halo or alkoxy, and haloalkoxy substituents;
- (v) C_{4 to 20} alkenyl or C_{4 to 20} alkynyl, optionally substituted with one or more substituents independently selected from halo, alkoxy, or haloalkoxy;
- (vi) -Z-((CF₂)_q(CF₃))_r, wherein Z is a C_{1 to 12} divalent alkane radical or a C_{2 to 12} divalent alkene or alkyne radical, q is an integer from 1 to 12, and r is an integer from 1-4);

each X is independently selected from -H, -Cl, -I, -Br, -OH, -OR², -NHR³, or -N(R³)₂;

each R² is independently selected from C_{1 to 4} alkyl or haloalkyl group; and

each R³ is independently an independently selected H, C_{1 to 4} alkyl or haloalkyl group.

24. The method of any of claims 14-23, wherein said second particles are prepared by treating a particle having a size of about 1 nm to 25 μm with a silanizing agent selected from: tridecafluoro-1,1,2,2-tetrahydrooctyl)silane (SIT8173.0); (tridecafluoro-1,1,2,2-tetrahydrooctyl) trichlorosilane (SIT8174.0); (tridecafluoro-1,1,2,2-tetrahydrooctyl)triethoxysilane (SIT8175.0); (tridecafluoro-1,1,2,2-tetrahydrooctyl)trimethoxysilane (SIT8176.0); (heptadecafluoro-1,1,2,2-tetrahydrodecyl)dimethyl(dimethylamino)silane (SIH5840.5); (heptadecafluoro-1,1,2,2-tetrahydrodecyl)tris(dimethylamino)silane (SIH5841.7); n-octadecyltrimethoxysilane (SIO6645.0); n-octyltriethoxysilane (SIO6715.0); and nonafluorohexyldimethyl(dimethylamino)silane (SIN6597.4).

25. The method any of claims 14-24, wherein said second particles are prepared by treating a particle having a size of about 1 nm to 25 μm with a silanizing agent selected from: dimethyldichlorosilane, hexamethyldisilazane, octyltrimethoxysilane, polydimethylsiloxane, or tridecafluoro-1,1,2,2-tetrahydrooctyl trichlorosilane.

26. The method of any of claims 14 to 25, wherein second particles have an average size in a range selected from about 1 nm to about 100 nm; about 10 nm to about 200 nm; about 20 nm to about 400 nm;

about 10 nm to 500 nm; about 40 nm to about 800 nm; about 100 nm to about 1 micron; about 200 nm to about 1.5 micron; about 500 nm to about 2 micron; about 500 nm to about 2.5 μm ; about 1.0 micron to about 10 μm ; about 2.0 micron to about 20 μm ; about 2.5 micron to about 25 μm ; about 500 nm to about 25 μm ; about 400 nm to about 20 μm ; and about 100nm to about 15 μm .

27. The method of any of claims 14 to 26, wherein said second particles comprise: a metal oxide, an oxide of a metalloid, a silicate, or a glass.

28. The method of any of claims 14-27, wherein said hydrophobic coating is resistant to 200 abrasion cycles on a Taber Model: 503 instrument using CS-10 wheels with 250 g load without loss of hydrophobicity.

29. The method of claim 14, wherein said method is a one-step process and said composition comprising a binder includes said second particles comprising a hydrophobic moiety

30. The method of claim 14, wherein said method is a two-step process and said composition comprising a binder does not comprise second particles bearing a hydrophobic moiety.

31. The method of claim 29 or claim 30, wherein said first particles do not comprise a hydrophobic moiety.

32. The method of any of claims 29 to 31, wherein said binder is an water-based binder system.

33. The method of claim 32, wherein said water-based binder system comprises a polyurethane.

34. A two-step method of forming a hydrophobic coating on at least a portion of a surface comprising:

i) applying a composition comprising a water-based binder on said at least a portion of a surface, wherein said composition comprising a binder optionally includes first particles having a size of about 30 μm to about 225 μm ; and

ii) applying to said binder on said at least a portion of said surface second particles a having a size of about 1 nm to about 25 μm ;

wherein said second particles comprising one or more independently selected hydrophobic and/or oleophobic moieties; and wherein said applying to said binder comprises applying a liquid composition comprising said second particle, or spray coating of said second particles using a stream of gas where the second particles comprise less than 2% by weight of a solvent.

35. The method of claim 34 wherein applying said second particles comprises applying suspension of said second particles in a liquid or applying said second particles using a stream of gas.

36. A one-step method of forming a hydrophobic coating on at least a portion of a surface comprising applying a composition comprising:

(i) a water-based binder on said at least a portion of a surface, and (ii) wherein said composition comprising a binder optionally includes first particles having a size of about 30 μm to about 225 μm , and second particles a having a size of about 1 nm to about 25 μm ;

wherein said second particles comprise one or more independently selected hydrophobic and/or oleophobic moieties.

37. The method of any of claims 34-36, wherein said first particles having a size of greater than about 30 μm in one dimension.

38. The method of any of claims 34-37, wherein said first particles have an average diameter greater than about 30 μm and less than about 225 μm .

39. The method of claims 34-37, wherein the binder comprises a polyurethane, lacquer, fluoropolymer, or an epoxy coating composition.

40. The method of claims 39, wherein the binder comprises polyurethane or epoxy coating composition.

41. The method of any of claims 34-40, wherein said first particles and/or said second particles comprise one or more independently selected hydrophobic and/or oleophobic moieties covalently bound to said first or second particles.

42. The method of claim 41, wherein said one or more hydrophobic and/or oleophobic moieties comprise one or more independently selected alkyl, fluoroalkyl or perfluoroalkyl moieties.

43. The method of claim 42, wherein said first particles and/or second particles comprise one or more covalently bound hydrophobic or oleophobic moieties of the form:

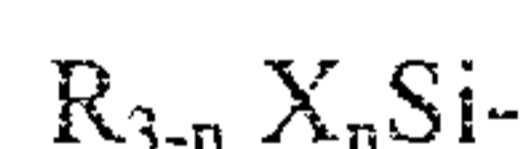

where n is an integer from 0 to 2;

each R is independently selected from

- (i) alkyl or cycloalkyl group optionally substituted with one or more fluorine atoms,
- (ii) C_{1-20} alkyl optionally substituted with one or more independently selected substituents selected from fluorine atoms and C_{6-14} aryl groups, which aryl groups are optionally substituted with one or more independently selected halo, C_{1-10} alkyl, C_{1-10} haloalkyl, C_{1-10} alkoxy, or C_{1-10} haloalkoxy substituents,
- (iii) C_{6-20} alkyl ether optionally substituted with one or more substituents independently selected from fluorine and C_{6-14} aryl groups, which aryl groups are optionally substituted with one or more independently selected halo, C_{1-10} alkyl, C_{1-10} haloalkyl, C_{1-10} alkoxy, or C_{1-10} haloalkoxy substituents,
- (iv) C_{6-14} aryl, optionally substituted with one or more substituents independently selected from halo or alkoxy, and haloalkoxy substituents;

- (v) $C_{4\text{ to }20}$ alkenyl or $C_{4\text{ to }20}$ alkynyl, optionally substituted with one or more substituents independently selected from halo, alkoxy, or haloalkoxy;
- (vi) $-Z-((CF_2)_q(CF_3))_r$, wherein Z is a $C_{1\text{ to }12}$ divalent alkane radical or a $C_{2\text{ to }12}$ divalent alkene or alkyne radical, q is an integer from 1 to 12, and r is an integer from 1-4);
- each X is independently selected from -H, -Cl, -I, -Br, -OH, -OR², -NHR³, or -N(R³)₂;
- each R² is independently selected from $C_{1\text{ to }4}$ alkyl or haloalkyl group; and
- each R³ is independently an independently selected H, C1 to 4 alkyl or haloalkyl group.

44. The method of any of claims 34-42, wherein said second particles are prepared by treating a particle having a size of about 1 nm to 25 μm with a silanizing agent selected from: tridecafluoro-1,1,2,2-tetrahydrooctyl)silane (SIT8173.0); (tridecafluoro-1,1,2,2-tetrahydrooctyl) trichlorosilane (SIT8174.0); (tridecafluoro-1,1,2,2-tetrahydrooctyl)triethoxysilane (SIT8175.0); (tridecafluoro-1,1,2,2-tetrahydrooctyl)trimethoxysilane (SIT8176.0); (heptadecafluoro-1,1,2,2-tetrahydrodecyl)dimethyl(dimethylamino)silane (SIH5840.5); (heptadecafluoro-1,1,2,2-tetrahydrodecyl)tris(dimethylamino)silane (SIH5841.7); n-octadecyltrimethoxysilane (SIO6645.0); n-octyltriethoxysilane (SIO6715.0); and nonafluorohexyldimethyl(dimethylamino)silane (SIN6597.4).

45. The method any of claims 34-42, wherein said second particles are prepared by treating a particle having a size of about 1 nm to about 25 μm with a silanizing agent selected from: dimethyldichlorosilane, hexamethyldisilazane, octyltrimethoxysilane, polydimethylsiloxane, or tridecafluoro-1,1,2,2-tetrahydrooctyl trichlorosilane.

46. The method of any of claims 34-45, wherein second particles have an average size in a range selected from about 1 nm to about 100 nm; about 10 nm to about 200 nm; about 20 nm to about 400 nm; about 10 nm to 500 nm; about 40 nm to about 800 nm; about 100 nm to about 1 micron; about 200 nm to about 1.5 micron; about 500 nm to about 2 micron; about 500 nm to about 2.5 μm ; about 1.0 micron to about 10 μm ; about 2.0 micron to about 20 μm ; about 2.5 micron to about 25 μm ; about 500 nm to about 25 μm ; about 400 nm to about 20 μm ; and about 100nm to about 15 μm .

47. The method of any of claims 34-46, wherein said second particles comprise: a metal oxide, an oxide of a metalloid, a silicate, or a glass.

48. The method of any of claims 34 -47 wherein said hydrophobic coating is resistant to 200 abrasion cycles on a Taber Model: 503 instrument using CS-10 wheels with 250 g load without loss of hydrophobicity.

49. The method of any of claims 34-48, wherein said first particles do not comprise a hydrophobic moiety.

50. A two-step coating composition comprising two separate components:

i) a first component comprising a water-based binder, wherein said first component optionally includes first particles having a size from about 30 μm to about 225 μm ; and

ii) a second component comprising second particles a having a size of about 1 nm to about 25 μm ;

wherein said second particles comprising one or more independently selected hydrophobic and/or oleophobic moieties.

51. A one-step coating composition comprising:

(i) a water-based binder; and

(ii) second particles a having a size of about 1 nm to about 25 μm ;

wherein said composition optionally comprises first particles having a size from about 30 μm to about 225 μm ; and wherein said second particles comprise one or more independently selected hydrophobic and/or oleophobic moieties.

52. The composition of any of claims 50-51, further comprising first particles wherein said first particles have a size of greater than about 30 μm in one dimension.

53. The composition of any of claims 50-52, wherein said first particles have an average diameter grater than about 30 μm and less than about 225 μm .

54. The composition of claims 50-53, wherein the binder comprises a polyurethane, lacquer, fluoropolymer, or an epoxy coating composition.

55. The composition of claims 54, wherein the binder comprises polyurethane or epoxy coating composition.

56. The composition of any of claims 50-55, wherein said first particles and/or said second particles comprise one or more independently selected hydrophobic and/or oleophobic moieties covalently bound to said first or second particles.

57. The composition of claim 56, wherein said one or more hydrophobic and/or oleophobic moieties comprise one or more independently selected alkyl, fluoroalkyl or perfluoroalkyl moieties.

58. The composition of claim 56, wherein said first particles and/or second particles comprise one or more covalently bound hydrophobic or oleophobic moieties of the form:

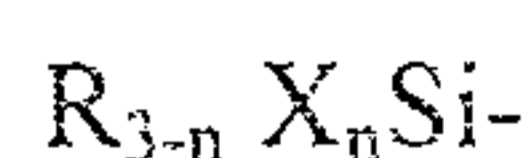

where n is an integer from 0 to 2;

each R is independently selected from

(i) alkyl or cycloalkyl group optionally substituted with one or more fluorine atoms,

- (ii) C_{1 to 20} alkyl optionally substituted with one or more independently selected substituents selected from fluorine atoms and C_{6 to 14} aryl groups, which aryl groups are optionally substituted with one or more independently selected halo, C_{1 to 10} alkyl, C_{1 to 10} haloalkyl, C_{1 to 10} alkoxy, or C_{1 to 10} haloalkoxy substituents,
- (iii) C_{6 to 20} alkyl ether optionally substituted with one or more substituents independently selected from fluorine and C_{6 to 14} aryl groups, which aryl groups are optionally substituted with one or more independently selected halo, C_{1 to 10} alkyl, C_{1 to 10} haloalkyl, C_{1 to 10} alkoxy, or C_{1 to 10} haloalkoxy substituents,
- (iv) C_{6 to 14} aryl, optionally substituted with one or more substituents independently selected from halo or alkoxy, and haloalkoxy substituents;
- (v) C_{4 to 20} alkenyl or C_{4 to 20} alkynyl, optionally substituted with one or more substituents independently selected from halo, alkoxy, or haloalkoxy;
- (vi) -Z-((CF₂)_q(CF₃))_r, wherein Z is a C_{1 to 12} divalent alkane radical or a C_{2 to 12} divalent alkene or alkyne radical, q is an integer from 1 to 12, and r is an integer from 1-4);
- each X is independently selected from -H, -Cl, -I, -Br, -OH, -OR², -NHR³, or -N(R³)₂;
- each R² is independently selected from C_{1 to 4} alkyl or haloalkyl group; and
- each R³ is independently an independently selected H, C_{1 to 4} alkyl or haloalkyl group.

59. The composition of any of claims 50-56, wherein said second particles are prepared by treating a particle having a size of about 1 nm to 25 μm with a silanizing agent selected from: tridecafluoro-1,1,2,2-tetrahydrooctyl)silane (SIT8173.0); (tridecafluoro-1,1,2,2-tetrahydrooctyl) trichlorosilane (SIT8174.0); (tridecafluoro-1,1,2,2-tetrahydrooctyl)triethoxysilane (SIT8175.0); (tridecafluoro-1,1,2,2-tetrahydrooctyl)trimethoxysilane (SIT8176.0); (heptadecafluoro-1,1,2,2-tetrahydrodecyl)dimethyl(dimethylamino)silane (SIH5840.5); (heptadecafluoro-1,1,2,2-tetrahydrodecyl)tris(dimethylamino)silane (SIH5841.7); n-octadecyltrimethoxysilane (SIO6645.0); n-octyltriethoxysilane (SIO6715.0); and nonafluorohexyldimethyl(dimethylamino)silane (SIN6597.4).

60. The composition any of claims 50-56, wherein said second particles are prepared by treating a particle having a size of about 1 nm to about 25 μm with a silanizing agent selected from: dimethyldichlorosilane, hexamethyldisilazane, octyltrimethoxysilane, polydimethylsiloxane, or tridecafluoro-1,1,2,2-tetrahydrooctyl trichlorosilane.

61. The composition of any of claims 50-60, wherein second particles have an average size in a range selected from about 1 nm to about 100 nm; about 10 nm to about 200 nm; about 20 nm to about 400 nm; about 10 nm to 500 nm; about 40 nm to about 800 nm; about 100 nm to about 1 micron; about 200 nm to about 1.5 micron; about 500 nm to about 2 micron; about 500 nm to about 2.5 μm; about 1.0 micron to about 10 μm; about 2.0 micron to about 20 μm; about 2.5 micron to about 25 μm; about 500 nm to about 25 μm; about 400 nm to about 20 μm; and about 100nm to about 15 μm.

62. The composition of any of claims 50-61, wherein said second particles comprise: a metal oxide, an oxide of a metalloid, a silicate, or a glass.
63. The composition of any of claims 50-62, wherein said hydrophobic coating is resistant to 40, 50, 60, 70, 80, 90, 100, 200, 250, 300, 350 or 400 abrasion cycles on a Taber Model: 503 instrument using CS-10 wheels with 250 g load without loss of hydrophobicity.
64. The composition of any of claims 50-63, wherein said first particles do not comprise a hydrophobic moiety.
65. An article having a surface coated with a hydrophobic coating prepared by the method of any of claims 14 to 49.
66. The article of claim 65, wherein said hydrophobic coating is resistant to greater than 20, 40, 60, 80, 100, 120, 140, 160, 180, 200, 300, or 400 abrasion cycles abrasion cycles on a Taber Model: 503 instrument using CS-10 wheels with 250 g load.
67. The article according to claim 65, wherein said article is a plunger.
68. A coating prepared using the composition of any of claims 50-64.

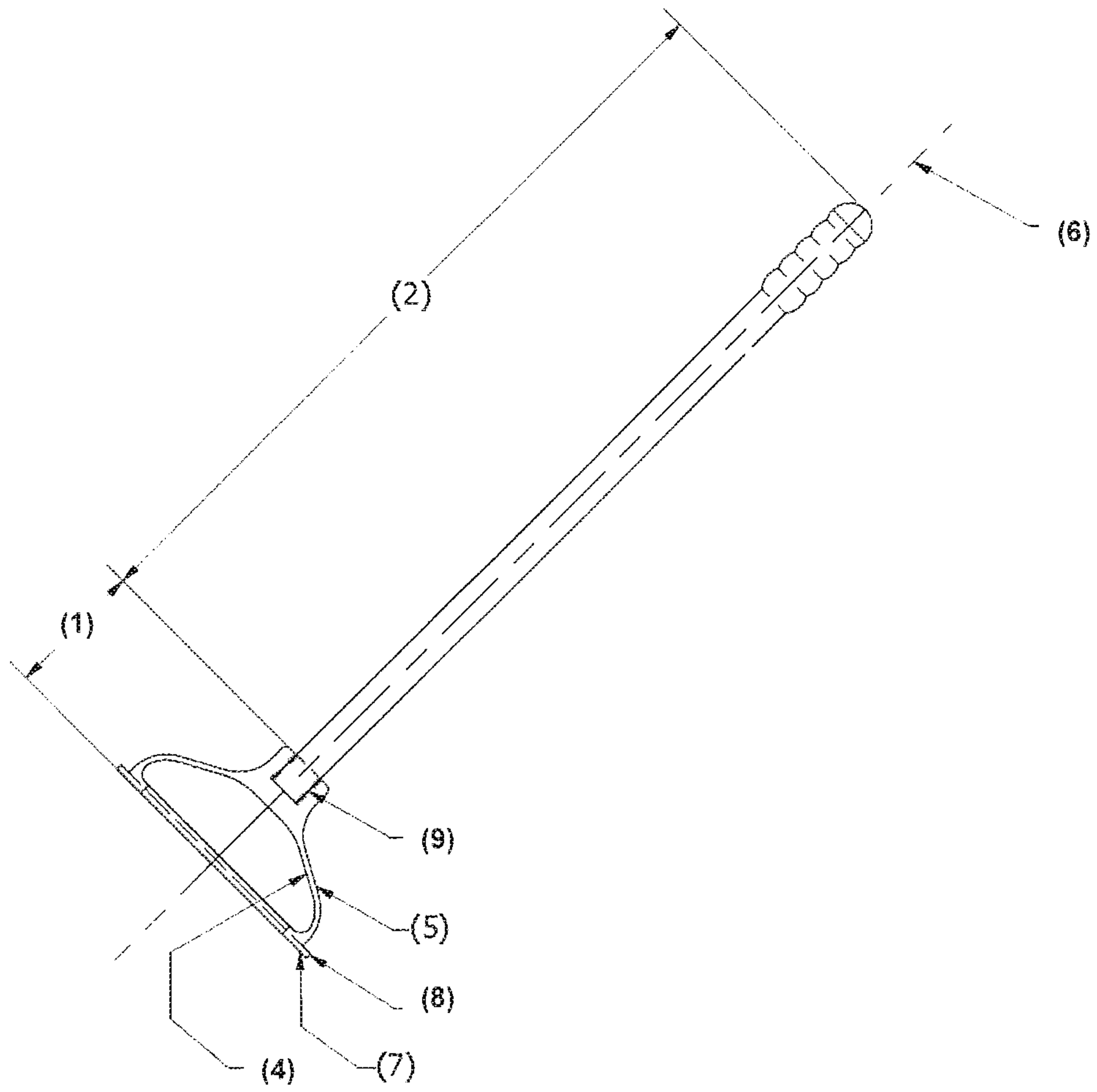

Figure 1

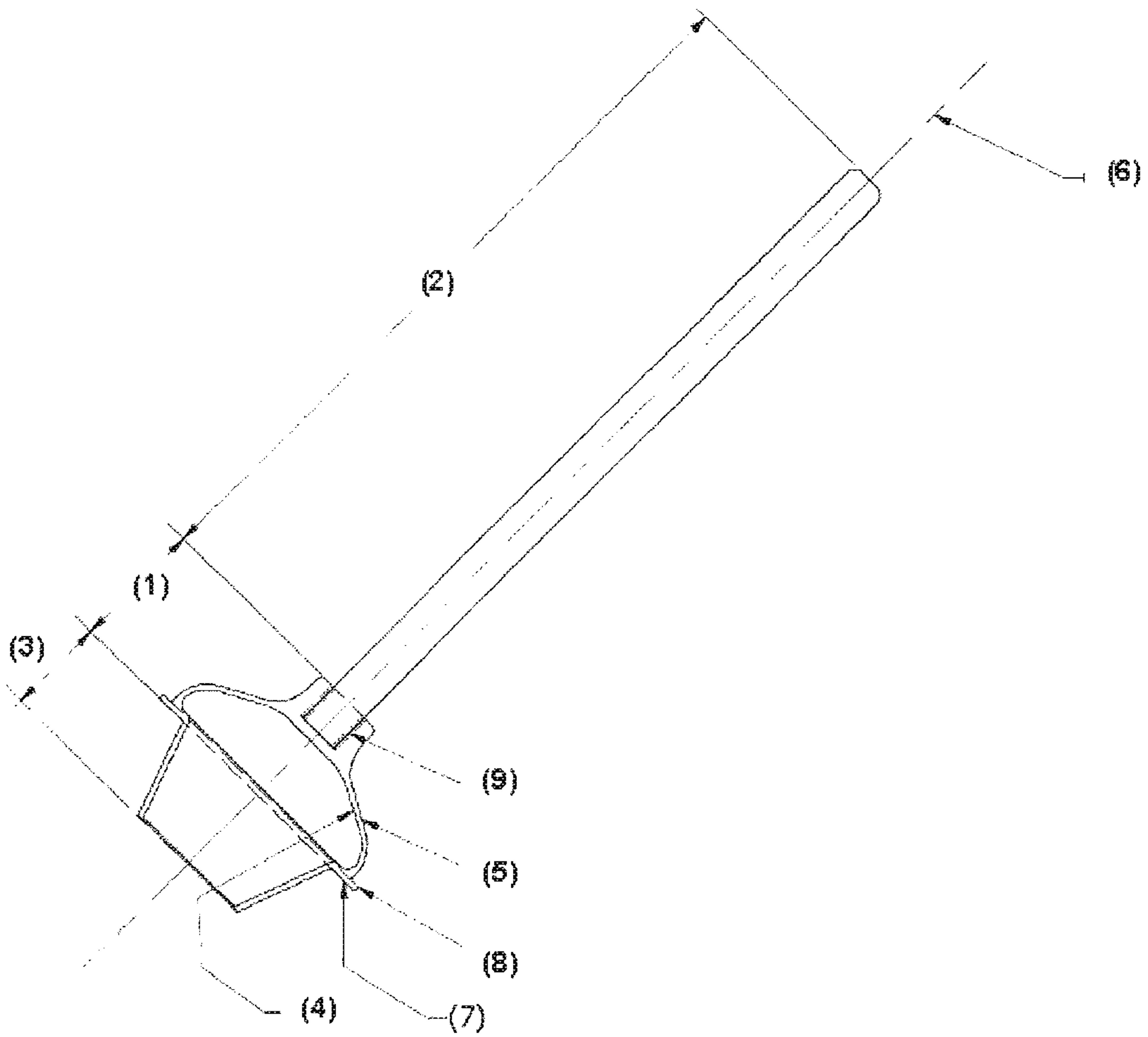

Figure 2

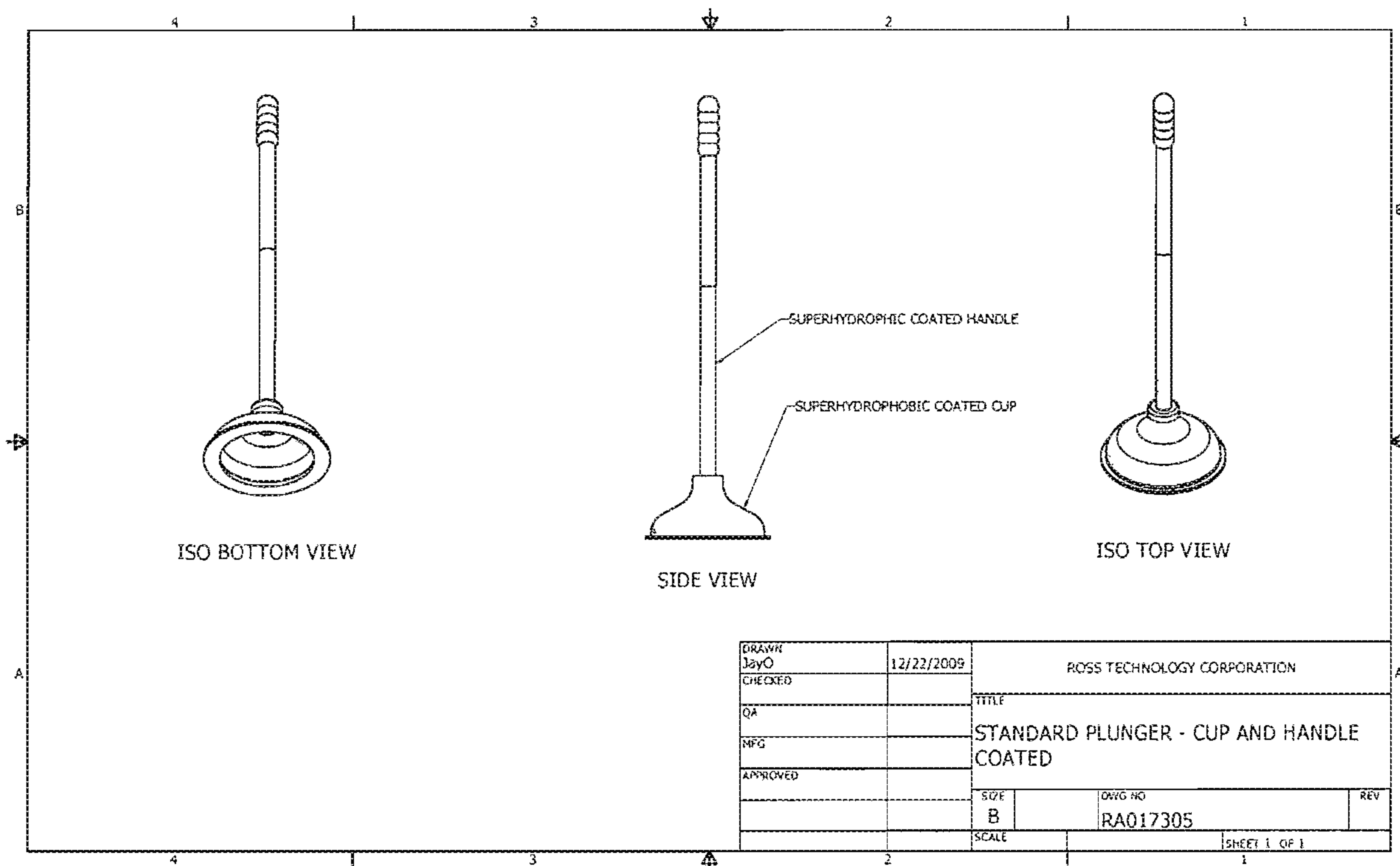

Figure 3: Coated cup and handle – household plunger.

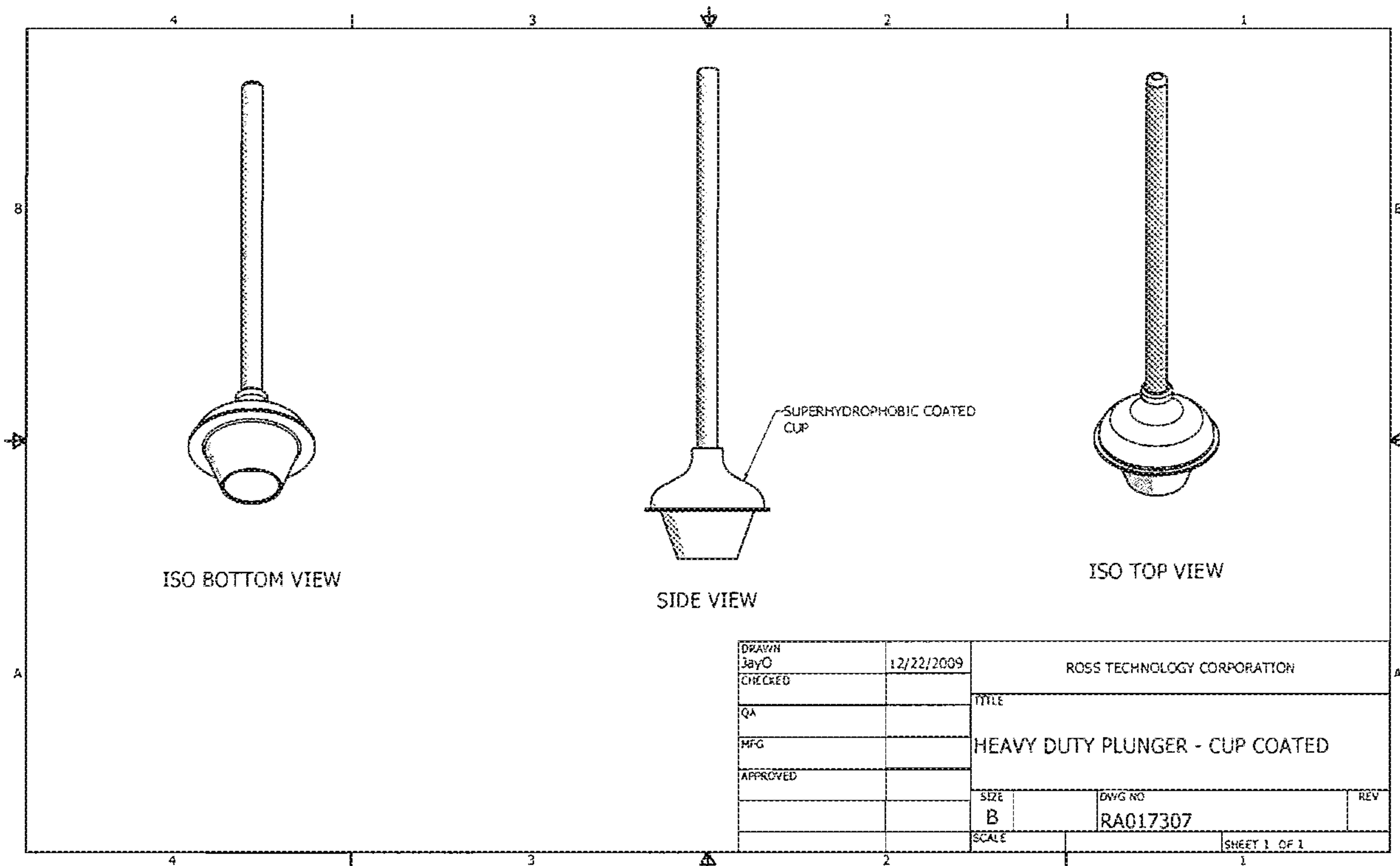

Figure 4: Coated cup – industrial plunger.

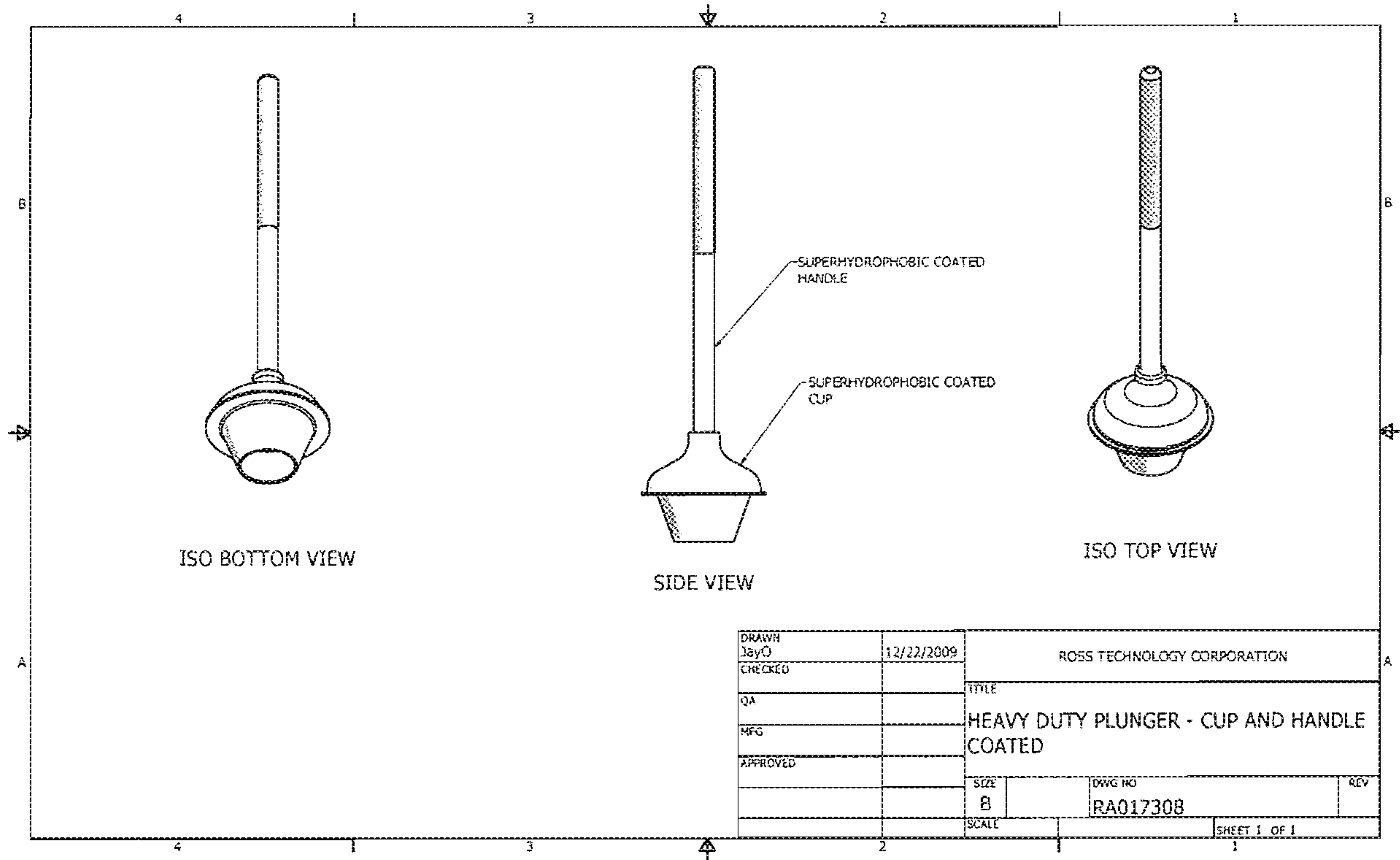

Figure 5: Coated cup and handle – industrial plunger.

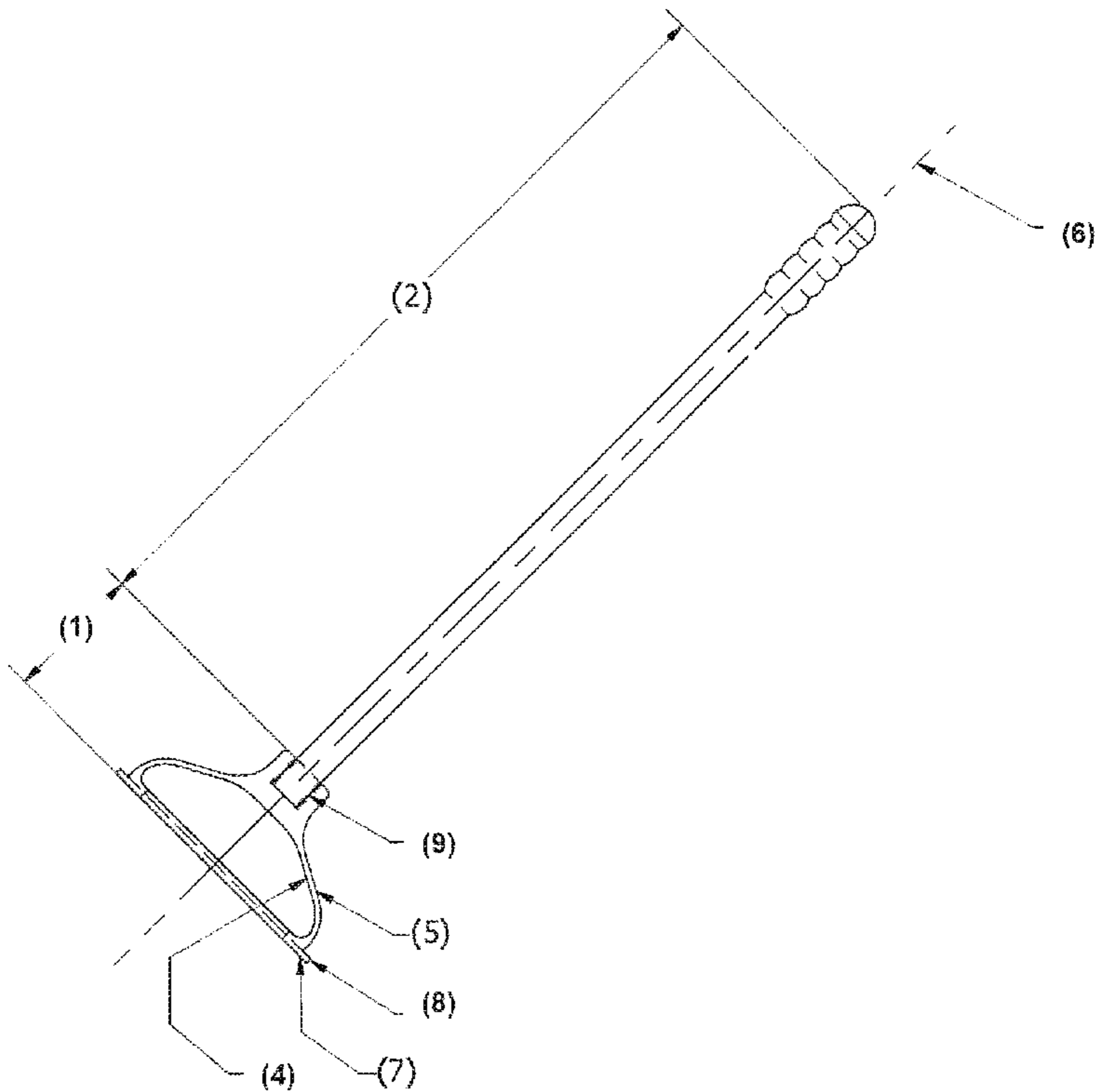

Figure 1