



(11) **EP 3 235 739 B1**

(12) **EUROPEAN PATENT SPECIFICATION**

(45) Date of publication and mention of the grant of the patent:
29.01.2020 Bulletin 2020/05

(51) Int Cl.:
B65B 21/04 (2006.01) B65B 35/54 (2006.01)

(21) Application number: **17167219.9**

(22) Date of filing: **20.04.2017**

(54) **METHOD AND ASSEMBLY FOR FEEDING MIXED BATCHES OF PRIMARY PRODUCTS**

VERFAHREN UND ANORDNUNG ZUM ZUFÜHREN VON GRUPPEN VON PRIMÄRPRODUKTEN

PROCÉDÉ ET ENSEMBLE D'ACHEMINEMENT DE LOTS DE PRODUITS PRIMAIRES

(84) Designated Contracting States:
AL AT BE BG CH CY CZ DE DK EE ES FI FR GB GR HR HU IE IS IT LI LT LU LV MC MK MT NL NO PL PT RO RS SE SI SK SM TR

(30) Priority: **22.04.2016 IT UA20162844**

(43) Date of publication of application:
25.10.2017 Bulletin 2017/43

(73) Proprietor: **OCME S.r.l.**
43122 Parma (PR) (IT)

(72) Inventor: **GATTESCHI, Carlotta**
43121 PARMA (IT)

(74) Representative: **Branca, Emanuela et al**
Barzanò & Zanardo Milano S.p.A.
Via Borgonuovo, 10
20121 Milano (IT)

(56) References cited:
EP-A1- 1 459 985 DE-A1-102009 037 833
DE-A1-102014 107 558 DE-U1-202005 019 906

EP 3 235 739 B1

Note: Within nine months of the publication of the mention of the grant of the European patent in the European Patent Bulletin, any person may give notice to the European Patent Office of opposition to that patent, in accordance with the Implementing Regulations. Notice of opposition shall not be deemed to have been filed until the opposition fee has been paid. (Art. 99(1) European Patent Convention).

Description

[0001] The present invention relates to an assembly for feeding mixed batches of primary products and to a relative method.

[0002] A need increasingly present in the packaging industry is to produce mixed sales units containing single primary products, which may be bottles, containers or cans, having different features.

[0003] Typically, a sale unit is defined as a bundle, a tray or a closed cardboard. The primary products included within this mixed sales units may differ in content, color, labeling and in more complex cases in the shape of the bottle or container. In order to simplify the description, it is said that the primary products are of different "type" to define all of these possible differences.

[0004] An example may be a cardboard tray containing bottles of orange juice and lemonade.

[0005] Primary products can similarly denote units enclosed in primary packages to be inserted in a packaging machine for producing secondary packages.

[0006] From the plant point of view, according to the prior art, mixed sales units create major problems for the management of primary products. In fact, the primary products are typically filled by the same blowing and filling block on a single line. The filler in most cases is able to fill only one type of liquid at a time and then the change from one liquid to another requires a wash and a format change.

[0007] The problem of storing primary products of the same flavour or type for subsequent mixed re-packaging for the external market must be managed accordingly. It is also not always established that single-flavour products are made specifically for re-packaging, but these products may be required to be placed on the market directly.

[0008] Typically, this storage requires palletizing single-flavour primary products, a pallet handling to and from the warehouse, one or more depalletizers that depalletize the single-flavour primary products in the respective flavour to be packaged in the mixed sales units and carry the primary products on single-row conveyors, a combiner plus a divider for loose articles that generate the desired mix on the various inlet channels to the packaging machine. As speeds increase, combiner and divider become very complex, thus becoming the performance bottleneck of the system.

[0009] Alternatively, the mixing of flavours may be left to the store before they are exposed. Manual mixing is very expensive due to the large number of people needed and requires a dedicated area.

[0010] In general, the depalletizing of primary products causes the presence at the packaging site of a large amount of paper or cardboard trays, emptied of the primary products, that require disposal.

[0011] By tray it is meant a sheet of paper or cardboard folded on all four sides to form two glued opposite outer sides and two sides orthogonal to the outer sides, pro-

vided at their ends with appendices forming inner flaps glued to glued outer flaps of the other sides.

[0012] Document DE 20 2005 019 906 U1 discloses an assembly for packaging bundles of mixed products that are fed by a series of conveyors, each feeding products of individual type.

[0013] The aim of the present invention is to provide an assembly for feeding mixed batches of primary products and a relative method which allows solving the drawbacks of the prior art.

[0014] Another aim of the present invention is to provide an assembly for feeding mixed batches of primary products and a relative method able to manage a large number of different primary products.

[0015] A further aim of the present invention is to provide an assembly for feeding mixed batches of primary products and a relative method able to be fed with both primary products from filling lines and with depalletized primary products.

[0016] A further aim of the present invention is to provide an assembly for feeding mixed batches of primary products and a relative method which allow recycling empty trays by opening the same without breaking them.

[0017] Another aim of the present invention is to provide an assembly for feeding mixed batches of primary products and a relative method particularly simple and functional, with limited costs and compact in size.

[0018] These aims according to the present invention are achieved by providing an assembly for feeding mixed batches of primary products and a relative method as set out in the independent claims.

[0019] Further characteristics are described in the dependent claims.

[0020] The characteristics and the advantages of an assembly for feeding mixed batches of primary products and a relative method according to the present invention will become apparent from the following exemplary and non-limiting description, made with reference to the accompanying schematic drawings, in which:

figure 1 is a plan view of a layout of a plant comprising an assembly for feeding mixed batches of primary products according to the invention;

figures 2 and 3 show an embodiment of the assembly for feeding mixed batches of primary products according to the invention in side elevation and in plane view, respectively;

figures 4A-4C show in a sequence multiple operations of partial deposition of a gripper of a handling unit on an inlet conveyor of a second embodiment of the feeding assembly of the invention;

figure 5 shows a gripping head of a handling unit of the assembly according to the invention, equipped with a gripper of a row of bottles;

figures 6A-6D show the gripping sequence of the row of bottles with the gripper of figure 5;

figure 7 shows a suction cup gripper of a robot of the tray recycling system of the assembly according to

the invention;

figures 8A-8D show the opening sequence of a glued flap of a paper tray through the suction cup head of figure 7;

figure 9 shows the subsequent opening of a side orthogonal to the glued flap of the tray through the suction cup head of figure 7;

figure 10 shows the final extraction of the tray from the suction cup head of figure 7.

[0021] With reference to the figures, an assembly for feeding mixed batches of primary products is shown, generally indicated with 10, which feeds mixed batches 11' of primary products 11, i.e. batches consisting of different primary products, towards a packaging machine 12 which packs them into bundles, trays or closed cardboards. By packaging machine it is meant a machine that adds a packaging to the incoming primary containers 11, such as a trayformer, a bundling machine or a packer.

[0022] By primary products it is meant loose units, as well as units packed into primary packaging, in both cases to be inserted in a packaging machine for creating a packaging around batches of primary products.

[0023] In an embodiment of the invention, shown in figure 1, upstream of the feeding assembly of mixed batches 10 a depalletizing station 13 is present, comprising a depalletizing robot 14, which picks up pallets of different primary containers from one or more conveyors 15, from related picking positions 15'. Such primary containers are contained, for example, within trays 111 that are picked by the gripper of the depalletizing robot 14 and placed layer by layer on a plurality of conveyor belts 16, shown in greater detail in figure 2. Each pallet of trays generally comprises homogeneous primary products 11, for example one flavor, previously palletized and stored for subsequent mixed palletizing. The conveyor belts 16 carry trays 111 each on a loading station 21 of a tray 111 or of a pallet of trays 111. The loading station 21 may in turn consist of a conveyor belt.

[0024] The assembly for feeding mixed batches 10 according to the invention comprises at least one handling unit, or robot, 20. The feeding unit 18 further comprises at least two distinct picking points 18 of primary products 11. The picking points 18 may for example consist of the loading stations 21 of a tray 111 or of a pallet of trays 111 or of at least one loading station 21 and at least one single-row continuous conveyor of primary products, not shown.

[0025] The example shows a number of picking points 18 equal to the number of handling units 20. Likewise, according to a configuration not shown, a same handling unit 20 may be operatively associated with a plurality of tray loading stations 21. In the minimum configuration of a single handling unit, the same will necessarily be associated with at least two picking points 18, consisting of single-row continuous conveyors and/or loading stations 21. In the configuration comprising two or more handling units 20, each of them may operate with one or more

picking points 18, consisting of single-row continuous conveyors and/or loading stations 21.

[0026] Each handling unit 20, of which figure 1 shows by way of example a number equal to four, is provided with a gripping head 22 comprising a gripper 23 of multiples of primary products 11 arranged in a single row. By "row of products" it is meant at least two products aligned with each other along a straight line.

[0027] Each handling unit 20, which is operatively associated with at least one of the picking points 18, is also operatively associated with an inlet conveyor 30, provided with continuous motion towards the packaging machine 12. As shown in figure 2, the inlet conveyor 30 may be located at a higher height with respect to the plane of the loading station 21. According to different embodiments, the inlet conveyor 30 may be a smooth conveyor or a conveyor provided with a plurality of channels 31 delimited by vertical plates 32 for the transport and accumulation of primary products 11 on separate rows. In the case of an inlet conveyor 30 provided with channels 31, a mechanical selection device 33 is also provided at the outlet end of the inlet conveyor 30 for the formation of batches 11' of primary products 11 (figure 3).

[0028] According to a first embodiment, the handling units 20 deposit the entire row of primary products 11 in tracking, that is to say, at approximately the same speed as the underlying conveyor, on the predetermined channel 31 of the inlet conveyor 30.

[0029] A second embodiment instead provides for the use of a gripper, not shown, consisting of independent portioned elements which allow the partial deposition of the primary products over several different rows.

[0030] According to a preferred embodiment, one or more channels 31 of the inlet conveyor 30 are not operatively associated with a handling unit 20 but are connected to a portionable channeling system 17 for feeding with a continuous flow of primary products 11, in parallel to the feeding on the remaining channels 31 through the handling units 20.

[0031] In the assembly for feeding mixed batches 10 according to the invention, the conveyor belts 16 carry trays 111 one after the other, spacing them, to the loading station 21, where one or more handling units, or a robot, 20 pick the rows of primary containers 11 from trays 111 placing them directly into channels 31 of the inlet conveyor 30 of the packaging machine 12. The handling units 20 are able to track in electric axis the inlet conveyor 30, so as to gently deposit the primary products 11, preventing any risk of falling. These sections are modular and the number of handling units 20 depends on the production mix and the production required. Each handling unit 20 can feed any number of channels 31 and pick from one or more loading stations 21.

[0032] In one embodiment of the feeding assembly 10, the gripper 23 picks one row of primary products 11 at a time and such a row is entirely deposited within a single channel 31. However, such an embodiment may be extended with the use of a gripper that picks a plurality of

primary products with independent clamping systems. In this way, the handling unit 20 can pick up a row of primary containers 11 and deposit them into separate channels 31, so as to achieve a mix of products that allows not having a simple mixing of product channel by channel, but a production mix that can achieve the deposition of the single primary product in the desired position within the packaging created by the packaging machine 12.

[0033] In addition, it is possible to operate the handling units 20 and the packaging machine 12 as a single machine, thus synchronizing the operations of the single handling units 20 with the step of the packaging machine 12. According to this configuration, it is possible to eliminate the channeling plates 32 from the inlet conveyor 30 and assign one or more batches 11' of primary containers that must be deposited at each step to each handling unit 20. The set of primary containers 11 deposited at the same machine step constitutes a so-called "virtual batch" which becomes the final pack of the packaging machine 12, without requiring a further selection and without the necessity of having to accumulate. This solution can be combined with a bottle selection device, located on the platform before the handling units 20 themselves, able to select primary containers from a production line on some rows, while the handling units 20 form the remaining rows of primary products 11 in steps.

[0034] If a gripping head 22 of the handling unit 20 is used, equipped with a gripper 23 able to pick multiples of primary products with independent clamping systems, used in association with a smooth inlet conveyor 30, that is to say, devoid of channels, figures 4A-4C show in sequence a possible deposition cycle, in which gripper 23 picks up a row of products from a tray 111 and deposits them through multiple operations of partial deposition on different rows to form a virtual batch 11'.

[0035] Figures 5 and 6A-6D show an embodiment of gripper 23 of multiples of primary products 11 arranged in a single row, adapted to pick up a row of primary containers consisting of bottles and release them all together on one row.

[0036] Gripper 23 comprises, according to this embodiment, two plates 24 parallel to each other and arranged in planes parallel to the plane containing the axis of the bottles. Plates 24 are provided with a continuous gripping tooth 25 along the entire inner bottom edge. The two plates 24 are movable in mutual approach to pick the bottles under the collar in the vicinity of the neck and are movable away to release the same.

[0037] The gripper 23, according to the embodiment suitable for gripping a row of bottles, also comprises a pressure bar 26 arranged between the two plates 24 and provided with a plane perpendicular to the axis of the bottles engageable in abutment on the tops of the bottle caps.

[0038] The gripping cycle shown in sequence in figures 6A-6D provides for lowering gripper 23 in the direction of the row of bottles, approaching the two plates 24 and placing teeth 25 in gripping under the collar of the bottles,

and lowering the pressure bar 26 against the cap of the bottles in a row. The row of bottles is thus picked up from the tray and placed on the inlet conveyor 30. Only after finishing the deposition of the row of bottles on the inlet conveyor 30, the pressure exerted by bar 26 is released and plates 24 are moved away from each other.

[0039] The assembly for feeding mixed batches 10 according to the invention can integrate a recycling system 40 of trays 111, either of paper or cardboard, in output from the loading station 21, which feeds them towards a tray processing unit. The tray processing unit picks them up, opens them and stacks them. In the example of figures 1 and 2, the tray recycling system 40 comprises a return structure of empty trays 111 positioned underneath the inlet conveyor 30 to the packaging machine 12.

[0040] The tray processing unit comprises a robot 41 provided with a suction cup gripping head 42, identifying a quadrilateral perimeter of size adjustable as a function of the size of trays 111. The suction cup gripping head 42 comprises four gripper elements 43 placed in pairs at ends of two opposite sides of the perimeter, associable with pairs of opposite glued flaps, outer 111A and inner 111'A, of the tray 111. Each gripper element 43 is provided with a first set of inner suction cups 44 that are engageable in translation by means of linear actuators 56 against the inner glued flap 111'A of the tray, and a tear device, which can be engaged to the outer glued flap 111A of the tray by means of a tilting arm 46, adapted to detach flap 111A of tray 111 with the rotary movement thereof. The tear device causes the detachment of the two glued flaps, outer 111A and inner 111'A following the detachment of the glue and not the breakage of the cardboard. The tear device, according to a preferred embodiment, may comprise a second set of outer suction cups 45, engageable against the outer glued flap 111A of the tray, associated with a hook 54, actuable via a linear actuator 55, for the engagement in hooking with the glued side of tray 111 from the inside thereof. The hook 54, which may also be associated to one of the two gripper elements 43, engaged with a pair of glued flaps 111A, 111'A, as shown for example in figure 7, is positioned along the side of tray 111 so as not to be engaged with the inner glued flap 111'A. It is in fact positioned more centrally with respect to the second set of outer suction cups 45. According to a further embodiment, not shown, the hook 54 may be absent or be associated with all the gripper elements.

[0041] According to the preferred embodiment, as shown schematically in the sequence of figures 8A-8D, the outer 45 and inner 44 suction cups are closed in sequence against the glued flaps 111A and 111'A, while the hook 54 is in an extracted rest position. The vacuum generation within the same ensures the grip on the corresponding glued flaps 111A and 111'A. The hook 54 is then moved by translation to the engagement position thereof with the inner glued side of the tray. The outer suction cups 45 and the hook 54 are made to rotate around a fulcrum 47, placed about around at the outer

glued flap fold 111A, through the engagement of a linear actuator 48 on a tilting arm 49 rigidly connected in parallel to arm 46. During the rotation step, the hook 54 helps to pull the glued flap 111A preventing the detachment of the outer suction cup 45, carrying out a synergistic action to obtain the detachment of the glued flaps 111A and 111'A with minimum deformation of tray 111. The hook 54 is then returned to an extracted resting position.

[0042] According to the simplified embodiment, without hook 54, the closing and tearing cycle of the pair of suction cups 44, 45 is carried out in the same manner described above. Once the vacuum is generated inside the suction cups 44 and 45, the outer suction cups 45 are rotated around fulcrum 47, placed about at the outer glued flap fold 111A, through the engagement of the linear actuator 48 on the tilting arm 49 rigidly connected in parallel to arm 46.

[0043] Different tear devices may form part of the invention in place or integration of the outer suction cups 45 and of the hook 54 described.

[0044] The suction cup gripping head 42 also comprises a pair of presser elements 50 placed at the remaining two sides 111B of tray 111, respectively, orthogonal to the glued flaps 111A and 111'A. Each presser element 50, preferably provided with a wide flat thrust surface, is hinged at the fold of side 111B of tray 111, orthogonal to glued flaps 111A and 111'A, and connected to a linear actuator 51. The presser elements 50 rotate orthogonally to the tearing direction of the outer glued flap 111A to act each on a side orthogonal to the gluing side of the tray, to complete the opening of the orthogonal sides 111B and flattening of the tray, as shown in figure 9.

[0045] The suction cup gripping head 42 also comprises, in a position inside the quadrilateral perimeter, a plurality of vertical linear actuators 52 arranged orthogonally to the tray plane, provided at the lower ends with suction cups 53, adapted to keep the open tray 111 open and facilitate the removal thereof from the suction cup gripping head 42 for the deposition on a stack of open trays by pushing the open tray downwards (figure 10).

[0046] The method for feeding mixed batches of primary products to a packaging machine, according to the invention, comprises the steps of:

- picking in sequence multiples of primary products 11, arranged in a row, from at least two distinct picking points 18 through at least one handling unit 20, from continuously fed channels or from a tray or a pallet of trays;
- depositing in tracking the rows of primary products along rows that are side by side to one another on an inlet conveyor 30 that continuously transfers the rows of primary products 11 towards a packaging machine 12.

[0047] The tracking deposition step may relate to a whole row of products engaged by a gripper 23, deposited along the same row of the inlet conveyor 30, or it

may relate to subsets of the product row engaged by gripper 23, deposited along multiple rows of the inlet conveyor 30.

[0048] The tracking deposition step may be carried out within channels 31 of the inlet conveyor 30 or directly on the smooth conveyor.

[0049] The method for feeding mixed batches of primary products to a packaging machine, according to the invention, also comprises the step of:

- feeding primary products 11 on the inlet conveyor 30 through a portionable channeling system 17, parallel to the deposition with the handling unit 20. The side-by-side rows of primary products present on the inlet conveyor 30 are partly fed by the handling unit 20 and partly by the portionable channeling system 17.

[0050] The method according to the invention finally comprises a feeding step of empty trays 111 from the loading station 21 towards a tray processing unit and an empty tray processing step.

[0051] The empty tray processing step comprising the steps of:

- engaging glued flaps 111A of the tray on opposite sides with a plurality of inner suction cups 44 and with a tear device, such as a plurality of outer suction cups 45 opposite to the inner suction cups 44 and/or a hook 54;
- detaching each outer glued flap 111A with a rotary action of the tear device and with such a rotary action aligning it with the plane of the tray 111;
- flattening the remaining two sides 111B of the tray 111, orthogonal to the glued flaps 111A and 111'A, with a rotary action orthogonal to the first one through a pair of hinged presser elements 50;
- depositing the tray thus opened onto a stack of trays.

[0052] The assembly for feeding mixed batches of primary products and the relative method according to the present invention have the advantage of implementing a line end able to work in mixed palletizing in a compact manner.

[0053] Advantageously, this solution in some embodiments thereof allows simultaneously working with one or more types of primary products coming from palletized products and with one or more products coming from the filling lines. This solution allows operation even with idle system parts, for example production can be done with primary products of one type only, coming directly from the production/filling lines and not from the depalletizing group.

[0054] The feeding assembly according to the present invention, in particular, simultaneously works with one or more types of primary products coming from palletized products and with one or more primary products coming from the filling lines.

[0055] Moreover, the suction cup gripping head of the tray recycling system of the feeding assembly according to the present invention advantageously allows ungluing the glued flaps without tearing the cardboard.

[0056] The assembly for feeding mixed batches of primary products and the relative method thus conceived may undergo numerous modifications and variations, all falling within the invention; moreover, all details can be replaced with technically equivalent elements. In practice, the materials used as well as the sizes, can be any, according to technical requirements.

Claims

1. Assembly for feeding mixed batches of primary products to a packaging machine comprising at least one handling unit, or robot, (20) for handling primary products (11), at least two distinct picking points (18, 21) for picking primary products (11) and a continuous inlet conveyor (30) towards a packaging machine, said at least one handling unit (20) being operatively associated with at least one of said primary products (11) picking points (18, 21) and operatively associated with said inlet conveyor (30), wherein said at least one handling unit (20) is equipped with a gripping head (22) comprising a gripper (23) for gripping multiples of primary products arranged in a row, for picking a row of primary products and for positioning at least a part of said row of primary products in tracking on said inlet conveyor (30) by positioning them at approximately the same speed as the underlying conveyor, **characterized in that** said inlet conveyor (30) is provided with a plurality of channels (31) for transporting primary products on separate rows and with a mechanical selection device (33) at the outlet end for the formation of batches (11') of primary products (11) and wherein at least one of said channels (31) of the inlet conveyor (30) is not operatively associated with said at least one handling unit (20) and is connected to a portionable channeling system (17) for feeding with a continuous flow of primary products (11), in parallel to the feeding on the remaining channels (31) through said at least one handling unit (20).
2. Feeding assembly according to claim 1, **characterized in that** said picking point of said handling unit (20) is a loading station (21) for loading a tray (111) or a pallet of trays (111).
3. Feeding assembly according to claim 2, **characterized in that** it comprises a tray-recycling system (40) exiting from the loading station (21) towards a tray transforming unit that picks them up, opens them and stacks them.
4. Feeding assembly according to claim 3, **character-**

ized in that said tray transforming unit comprises a robot (41) equipped with a suction cup head (42) identifying a quadrilateral perimeter of adjustable size, said suction cup head (42) comprising four gripper elements (43) placed in pairs at the ends of two opposite sides of the perimeter, associable with pairs of opposite glued flaps, outer and inner, (111A, 111'A) of the tray (111), wherein each gripper element (43) is equipped with a first set of inner suction cups (44) that are engageable from the inside against said inner glued flap (111'A) of the tray, and a tear device, preferably comprising a second set of outer suction cups (45) that are engageable from the outside against said outer glued flap (111A) of the tray, said tear device being applied to an arm (46) tilting about a fulcrum (47) adapted to detach said outer glued flap (111A) of the tray with its own rotary movement, wherein said tear device can also comprise a movable hook (54) for the engagement from the inside with the glued side of the tray (111).

5. Feeding assembly according to claim 4, **characterized in that** said suction cup head (42) also comprises a pair of hinged presser elements (50), placed respectively at the remaining two sides (111B) of the tray (111), orthogonal to the glued flaps (111A, and 111'A), adapted to act each on one side orthogonal to the gluing side of the tray that complete the opening and the flattening of the tray, said suction cup head (42) also comprising in an internal position in said quadrilateral perimeter a plurality of linear actuators (52) arranged orthogonally with respect to the plane of the tray, provided at the lower ends with suction cups (53), adapted to keep the open tray raised and facilitate its extraction from the suction cup head (42) for the deposit on a stack of open trays.
6. Method for feeding mixed batches of primary products to a packaging machine by means of an assembly for feeding mixed batches of products according to any of the preceding claims, comprising the steps of:
 - picking in a sequence multiples of primary products (11), arranged in a row, from at least two distinct picking points (18, 21) through at least one handling unit (20);
 - depositing in tracking said rows of primary products along rows that are side by side to one another on an inlet conveyor (30) by positioning them at approximately the same speed as the underlying conveyor that continuously transfers said rows of primary products (11) towards a packaging machine (12), wherein said step of depositing in tracking relates to an entire row of products gripped by a gripper (23) along a same row of the inlet conveyor (30) or subsets of the row of products

gripped by the gripper (23) along more rows of the inlet conveyor (30), **characterized in that** said step of depositing in tracking is carried out inside channels (31) of said inlet conveyor (30), the method further comprises the step of feeding
5 said primary products (11) on the inlet conveyor (30) through a portionable channeling system (17), in parallel to the deposit with the handling unit (20), said rows that are side by side to one
10 another of primary products on said inlet conveyor (30) being each fed by said handling unit (20) or by said portionable channeling system (17).

7. Method according to claim 6, **characterized in that** said step of picking rows of primary products from at least two distinct picking points (18) through at least one handling unit (20) is carried out by picking from continuously fed channels or from loading stations (21) for loading a tray or a pallet of trays.
20
8. Method according to any of claims 6 or 7, **characterized in that** it comprises a step of feeding empty trays (111) from the loading station (21) towards a tray transforming unit, and a step of transforming empty trays, wherein said tray transforming step comprises the steps of:

- engaging pairs of glued flaps (111A, 111'A) of the tray on opposite sides with a plurality of inner suction cups (44) and a tear device;
30
- detaching each outer glued flap (111A) and aligning it to the plane of the tray (111) with a rotary action of the tear device;
- flattening the remaining two sides (111B) of the tray (111), orthogonal to the glued flaps (111A, 111'A), with a rotary action orthogonal to the first one through a pair of hinged presser elements (50);
35
- depositing the tray thus open onto a stack of trays.
40

Patentansprüche

1. Anordnung zum Zuführen von Gruppen von Primärprodukten in eine Packmaschine, umfassend zumindest eine Handhabungseinheit oder Roboter (20) zur Handhabung von Primärprodukten (11), zumindest zwei verschiedene Kommissionierstellen (18, 21) für die Entnahme von Primärprodukten (11) und einen in Richtung einer Packmaschine kontinuierlich arbeitenden Zuförderer (30), wobei diese zumindest eine Handhabungseinheit (20) mindestens einer diese Primärprodukte (11) entnehmenden Kommissionierstelle (18, 21), sowie diesem Zuförderer (30) wirkungsmäßig zugeordnet ist, wobei diese zumindest eine Handhabungseinheit (20) mit einem Greifkopf
50

(22) ausgerüstet ist, der einen Greifer (23) zum Greifen von einer Mehrzahl von in einer Reihe angeordneten Primärprodukten, zur Entnahme einer Reihe von Primärprodukten und zur Positionierung zumindest eines Teiles dieser Reihe von auf diesem Zuförderer (30) nachverfolgten Primärprodukten umfasst, indem diese mit annähernd gleicher Geschwindigkeit wie der darunter liegende Förderer positioniert werden, **dadurch gekennzeichnet, dass** dieser Zuförderer (30) mit einer Vielzahl von Kanälen (31) zur Beförderung von Primärprodukten in getrennten Reihen und mit einer mechanischen Auswahlvorrichtung (33) am Austrittsende für die Bildung von Gruppen (11') von Primärprodukten (11) versehen ist und wobei zumindest ein dieser Kanäle (31) des Zuförderers (30) dieser mindestens einen Handhabungseinheit (20) nicht wirkungsmäßig zugeordnet ist und mit einem dosierbaren Kanalisierungssystem (17) für die Zuführung von Primärprodukten (11) im kontinuierlichen Fluss, parallel zur Zuführung auf den restlichen Kanälen (31), durch diese zumindest eine Handhabungseinheit (20) verbunden ist.

2. Zuführungsanordnung nach Anspruch 1, **dadurch gekennzeichnet, dass** die Kommissionierstelle dieser Handhabungseinheit (20) eine Beladestation (21) zum Beladen eines Tablars (111) oder einer Palette mit Tablaren (111) ist.
25
3. Zuführungsanordnung nach Anspruch 2, **dadurch gekennzeichnet, dass** sie ein System zur Wiederverwertung der Tablare (40) umfasst, die aus der Beladestation (21) in Richtung einer Tablar-Transformationseinheit fahren, welche die Tablare aufnimmt, öffnet und stapelt.
35
4. Zuführungsanordnung nach Anspruch 3, **dadurch gekennzeichnet, dass** die Tablar-Transformationseinheit einen Roboter (41) umfasst, der mit einem einen vierseitigen Umfang einstellbarer Größe identifizierenden Saugnapfkopf ausgestattet ist, wobei dieser Saugnapfkopf (42) vier Greifelemente (43) umfasst, die paarweise an den Enden von zwei gegenüberliegenden Seiten des Umfangs angeordnet sind, welche Paaren von gegenüberliegenden, äußeren und inneren geklebten Klappen (111A, 111'A) des Tablars (111) zuordenbar sind, wobei jedes Greifelement mit einer ersten Gruppe von inneren Saugnapfen, die von innen an diese innere geklebte Klappe (111'A) des Tablars in Eingriff bringbar sind, und einer Abtrennvorrichtung ausgestattet ist, bevorzugt umfassend eine zweite Gruppe von äußeren Saugnapfen (45), die von außen an diese äußere geklebte Klappe (111A) des Tablars in Eingriff bringbar sind, wobei diese Abtrennvorrichtung an einem, um einen Auflagepunkt (47) kippbaren Arm (46) angebracht ist, der dazu ausgelegt ist, diese äußere
45

geklebte Klappe (111A) des Tablars durch die eigene rotative Bewegung abzutrennen, wobei diese Abtrennvorrichtung auch einen bewegbaren Haken (54) für den Eingriff von innen mit der geklebten Seite des Tablars (111) umfassen kann.

5. Zuführungsanordnung nach Anspruch 4, **dadurch gekennzeichnet, dass** dieser Saugnapfkopf (42) zudem ein Paar angelenkter Andrückelemente (50) umfasst, die jeweils an den beiden verbleibenden Seiten (111B) des Tablars (111), orthogonal zu den geklebten Klappen (111A, und 111'A) platziert sind, welche dazu ausgebildet sind auf je einer Seite orthogonal zur geklebten Seite des Tablars zu wirken, um das 5-malige Öffnen und Abflachen des Tablars zu vervollständigen, wobei dieser Saugnapfkopf (42) weiter eine Vielzahl von Linearantrieben (52), in eine in diesem vierseitigen Umfang innenliegende Position, umfasst, die orthogonal zur Ebene des Tablars angeordnet sind und an den unteren Enden mit Saugnapfen (53) versehen sind, die geeignet sind das offene Tablar angehoben zu halten und dessen Herausziehen aus dem Saugnapfkopf (42) für die Ablage auf einen Stapel offener Tablare zu vereinfachen.

6. Methode zum Zuführen von Gruppen von Primärprodukten in eine Packmaschine mittels einer Anordnung zum Zuführen von Gruppen von Produkten nach einem der vorhergehenden Ansprüchen, umfassend folgende Schritte:

- Entnahme in einer Reihenfolge einer Vielzahl von in einer Reihe angeordneten Primärprodukten (11), aus zumindest zwei verschiedenen Kommissionierstellen (18, 21) durch mindestens eine Handhabungseinheit (20);
- Ablage und Nachverfolgung dieser Reihen von Primärprodukten entlang von Reihen, die aneinander Seite an Seite auf einen Zuförderer (30) mit annähernd gleicher Geschwindigkeit wie der darunter befindliche Förderer positioniert werden, der diese Reihen von Primärprodukten (11) kontinuierlich in Richtung einer Packmaschine (12) überführt,

wobei dieser Schritt der Ablage und Nachverfolgung sich auf eine ganze Reihe von Produkten bezieht, die von einem Greifer (23) entlang der gleichen Reihe des Zuförderers (30) ergriffen werden, oder auf Untergruppen der Reihe von Produkten bezieht, die vom Greifer (23) entlang mehrerer Reihen des Zuförderers (30) ergriffen werden, **dadurch gekennzeichnet, dass** dieser Schritt der Ablage und Nachverfolgung innerhalb von Kanälen (31) des Zuförderers (30) ausgeführt wird,

wobei die Methode ferner den Schritt des Zuführens dieser Primärprodukte (11) zu dem Zu-

förderer (30) durch ein dosierbares Kanalisierungssystem (17), parallel zur Ablage mit der Handhabungseinheit (20) umfasst, wobei jede dieser, aneinander Seite an Seite auf dem Zuförderer (30) befindlichen Reihen von Primärprodukten durch die Handhabungseinheit (20) oder durch das dosierbare Kanalisierungssystem (17) zugeführt wird.

7. Methode nach Anspruch 6, **dadurch gekennzeichnet, dass** dieser Schritt der Entnahme von Reihen von Primärprodukten aus zumindest zwei verschiedenen Kommissionierstellen (18) durch mindestens eine Handhabungseinheit (20) durch Entnahme aus kontinuierlich gespeisten Kanälen oder aus Beladestationen (21) zum Beladen eines Tablars oder einer Palette mit Tablaren ausgeführt wird.

8. Methode nach irgendeinem der Ansprüche 6 oder 7, **dadurch gekennzeichnet, dass** sie einen Schritt der Zuführung von leeren Tablaren (111) von der Beladestation (21) an eine Tablar-Transformationseinheit und einen Schritt zur Transformation von leeren Tablaren umfasst, wobei dieser Schritt zur Transformation von Tablaren folgende Schritte umfasst:

- Paare von geklebten Klappen (111A, 111 'A) auf gegenüberliegenden Seiten des Tablars mit einer Vielzahl von inneren Saugnapfen (44) und einer Abtrennvorrichtung in Eingriff bringen;
- Abtrennen jeder äußeren geklebten Klappe (111A) und diese an der Ebene des Tablars (111) mit einer Drehbewegung der Abtrennvorrichtung ausrichten;
- Abflachen der beiden verbleibenden Seiten des Tablars (111), orthogonal zu den geklebten Klappen 111'A), mit einer Drehbewegung orthogonal zur ersten Seite (111B) der Klappen (111A) durch ein Paar angelenkter Andrückelemente (50);
- Ablage des somit auf einen Stapel von Tablaren hin offenen Tablars.

Revendications

1. Ensemble d'acheminement de lots mélangés de produits primaires vers une machine d'emballage comprenant au moins une unité, ou un robot, de manipulation (20) pour manipuler des produits primaires (11), au moins deux points de prélèvement distincts (18, 21) pour prélever des produits primaires (11) et un convoyeur d'entrée (30) continu en direction d'une machine d'emballage, ladite au moins une unité de manipulation (20) étant associée de manière fonctionnelle avec au moins l'un desdits points de prélèvement (18, 21) de produits primaires (11) et

- associée de manière fonctionnelle avec ledit convoyeur d'entrée (30), dans lequel ladite au moins une unité de manipulation (20) est équipée d'une tête de préhension (22) comprenant un préhenseur (23) pour agripper des multiples de produits primaires agencés dans une rangée, pour prélever une rangée de produits primaires et pour positionner au moins une partie de ladite rangée de produits primaires en suivi sur ledit convoyeur d'entrée (30) en les positionnant à approximativement la même vitesse que le convoyeur sous-jacent, **caractérisé en ce que** ledit convoyeur d'entrée (30) est muni d'une pluralité de canaux (31) pour transporter des produits primaires sur des rangées distinctes et d'un dispositif de sélection mécanique (33) au niveau de l'extrémité de sortie pour la formation de lots (11') de produits primaires (11) et dans lequel au moins l'un desdits canaux (31) du convoyeur d'entrée (30) n'est pas associé de manière fonctionnelle avec ladite au moins une unité de manipulation (20) et est relié à un système de mise en canal divisible (17) pour un acheminement avec un flux continu de produits primaires (11), parallèlement à l'acheminement sur les canaux restants (31) par l'intermédiaire de ladite au moins une unité de manipulation (20).
2. Ensemble d'acheminement selon la revendication 1, **caractérisé en ce que** ledit point de prélèvement de ladite unité de manipulation (20) est une station de chargement (21) pour le chargement d'une barquette (111) ou d'une palette de barquettes (111).
3. Ensemble d'acheminement selon la revendication 2, **caractérisé en ce qu'**il comprend un système de recyclage de barquettes (40) sortant de la station de chargement (21) en direction d'une unité de transformation de barquettes qui les prélève, les ouvre et les empile.
4. Ensemble d'acheminement selon la revendication 3, **caractérisé en ce que** ladite unité de transformation de barquettes comprend un robot (41) équipé d'une tête à ventouses (42) identifiant un périmètre quadrilatéral de taille réglable, ladite tête à ventouses (42) comprenant quatre éléments préhenseurs (43) placés par paires aux extrémités de deux côtés opposés du périmètre, aptes à être associés à des paires de rabats collés opposés, externe et interne, (111A, 111'A) de la barquette (111), dans lequel chaque élément préhenseur (43) est équipé d'un premier ensemble de ventouses internes (44) qui sont aptes à être mises en prise à partir de l'intérieur contre ledit rabat collé interne (111'A) de la barquette, et d'un dispositif de déchirement, comprenant de préférence un second ensemble de ventouses externes (45) qui sont aptes à être mises en prise à partir de l'extérieur contre ledit rabat collé externe (111A) de la barquette, ledit dispositif de déchirement étant appliqué sur un bras (46) basculant autour d'un point d'appui (47) conçu pour détacher ledit rabat collé externe (111A) de la barquette avec son propre mouvement de rotation, dans lequel ledit dispositif de déchirement peut également comprendre un crochet mobile (54) pour la mise en prise à partir de l'intérieur avec le côté collé de la barquette (111).
5. Ensemble d'acheminement selon la revendication 4, **caractérisé en ce que** ladite tête à ventouses (42) comprend également une paire d'éléments presseurs articulés (50), placés respectivement sur les deux côtés restants (111B) de la barquette (111), orthogonaux aux rabats collés (111A, et 111'A), conçus pour agir chacun sur un côté orthogonal au côté de collage de la barquette qui complète l'ouverture et l'aplatissement de la barquette, ladite tête à ventouses (42) comprenant également, dans une position interne dans ledit périmètre quadrilatéral, une pluralité d'actionneurs linéaires (52) agencés de manière orthogonale par rapport au plan de la barquette, munis aux extrémités inférieures de ventouses (53), conçus pour maintenir la barquette ouverte relevée et faciliter son extraction de la tête à ventouses (42) pour le dépôt sur une pile de barquettes ouvertes.
6. Procédé d'acheminement de lots mélangés de produits primaires vers une machine d'emballage au moyen d'un ensemble d'acheminement de lots mélangés de produits selon l'une quelconque des revendications précédentes, comprenant les étapes consistant à :
- prélever en une séquence des multiples de produits primaires (11), agencés dans une rangée, à partir d'au moins deux points de prélèvement distincts (18, 21) par l'intermédiaire d'au moins une unité de manipulation (20) ;
 - déposer en suivi lesdites rangées de produits primaires le long de rangées qui sont côte à côte sur un convoyeur d'entrée (30) en les positionnant à approximativement la même vitesse que le convoyeur sous-jacent qui transfère en continu lesdites rangées de produits primaires (11) en direction d'une machine d'emballage (12), dans lequel ladite étape de dépôt en suivi se rapporte à une rangée entière de produits agrippée par un préhenseur (23) le long d'une même rangée du convoyeur d'entrée (30) ou à des sous-ensembles de la rangée de produits agrippée par le préhenseur (23) le long de plusieurs rangées du convoyeur d'entrée (30), **caractérisé en ce que** ladite étape de dépôt en suivi est réalisée à l'intérieur de canaux (31) dudit convoyeur d'entrée (30), le procédé comprend en outre l'étape consistant

à acheminer lesdits produits primaires (11) sur le convoyeur d'entrée (30) par l'intermédiaire d'un système de mise en canal divisible (17), parallèlement au dépôt avec l'unité de manipulation (20), lesdites rangées qui sont côte à côte de produits primaires sur ledit convoyeur d'entrée (30) étant chacune acheminées par ladite unité de manipulation (20) ou par ledit système de mise en canal divisible (17).

5

10

7. Procédé selon la revendication 6, **caractérisé en ce que** ladite étape de prélèvement de rangées de produits primaires à partir d'au moins deux points de prélèvement distincts (18) par l'intermédiaire d'au moins une unité de manipulation (20) est réalisée par un prélèvement à partir de canaux acheminés en continu ou à partir de stations de chargement (21) pour charger une barquette ou une palette de barquettes.

15

20

8. Procédé selon l'une quelconque des revendications 6 ou 7, **caractérisé en ce qu'il** comprend une étape consistant à acheminer des barquettes vides (111) à partir de la station de chargement (21) en direction d'une unité de transformation de barquettes, et une étape de transformation de barquettes vides, dans lequel ladite étape de transformation de barquettes comprend les étapes consistant à :

25

- mettre en prise des paires de rabats collés (111A, 111'A) de la barquette sur des côtés opposés avec une pluralité de ventouses internes (44) et un dispositif de déchirement ;
- détacher chaque rabat collé externe (111A) et l'aligner sur le plan de la barquette (111) avec une action rotative du dispositif de déchirement ;
- aplatir les deux côtés restants (111B) de la barquette (111), orthogonaux aux rabats collés (111A, 111'A), avec une action rotative orthogonale vers les premiers par l'intermédiaire d'une paire d'éléments presseurs articulés (50) ;
- déposer la barquette ainsi ouverte sur une pile de barquettes.

30

35

40

45

50

55

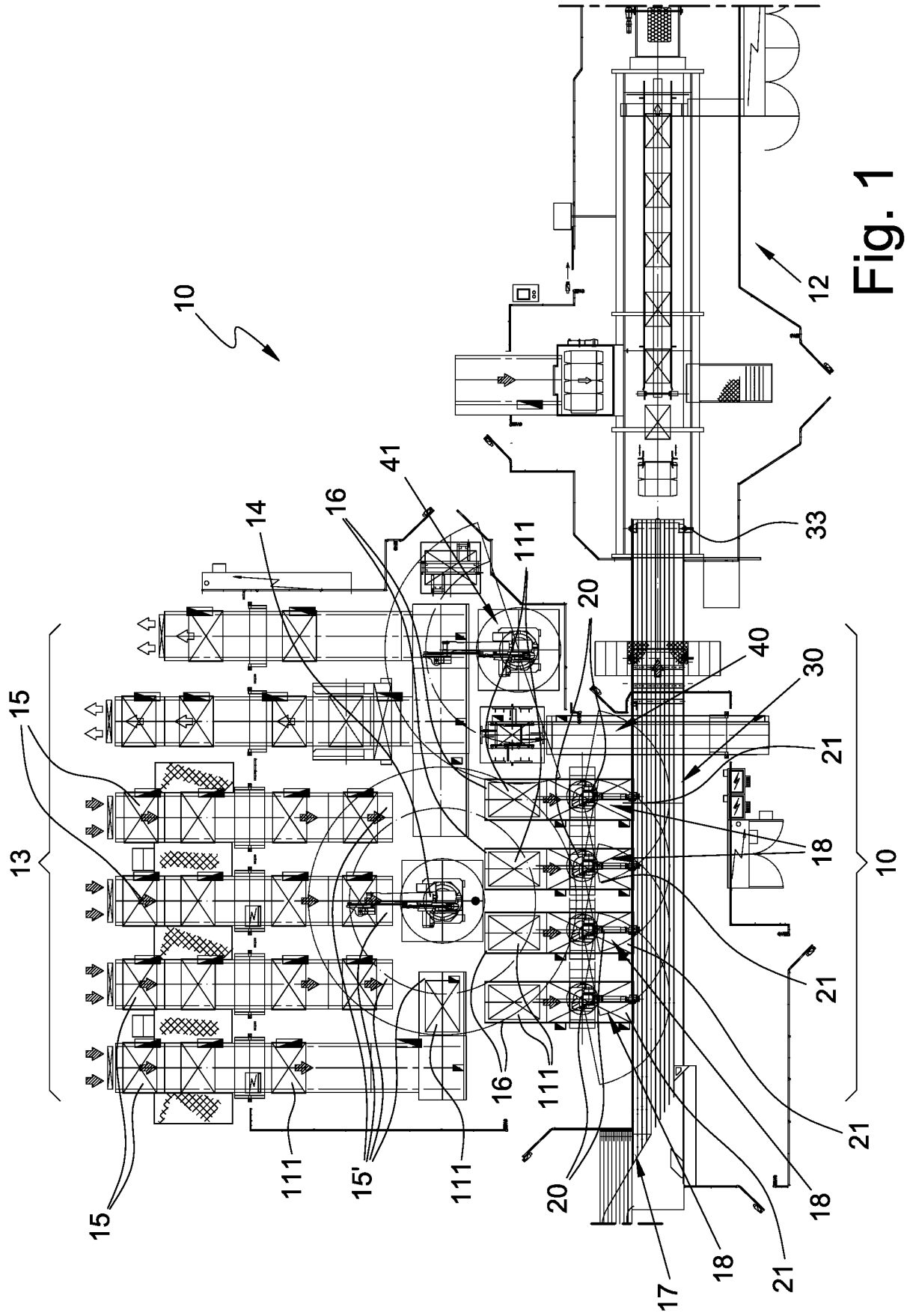

Fig. 1

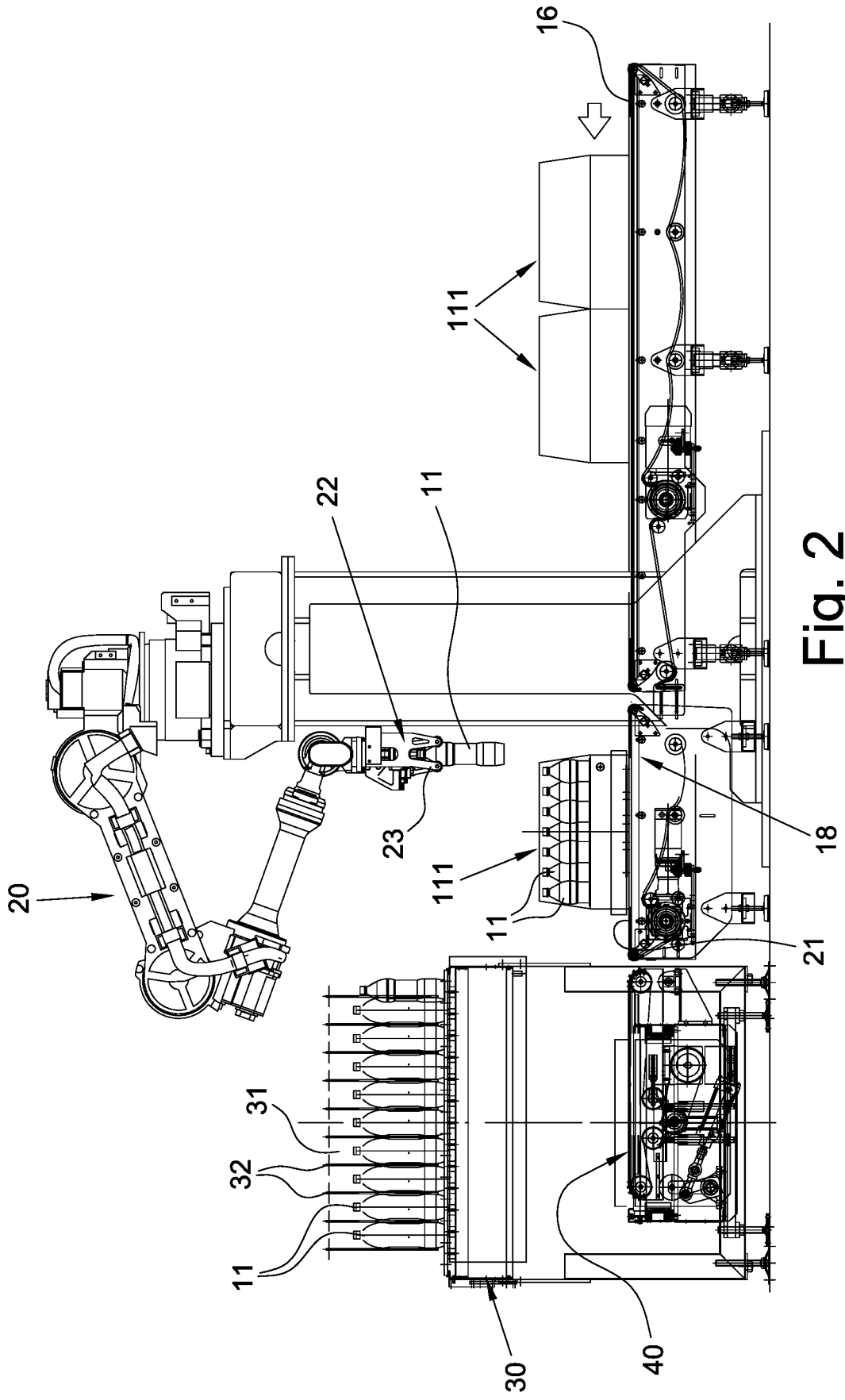

Fig. 2

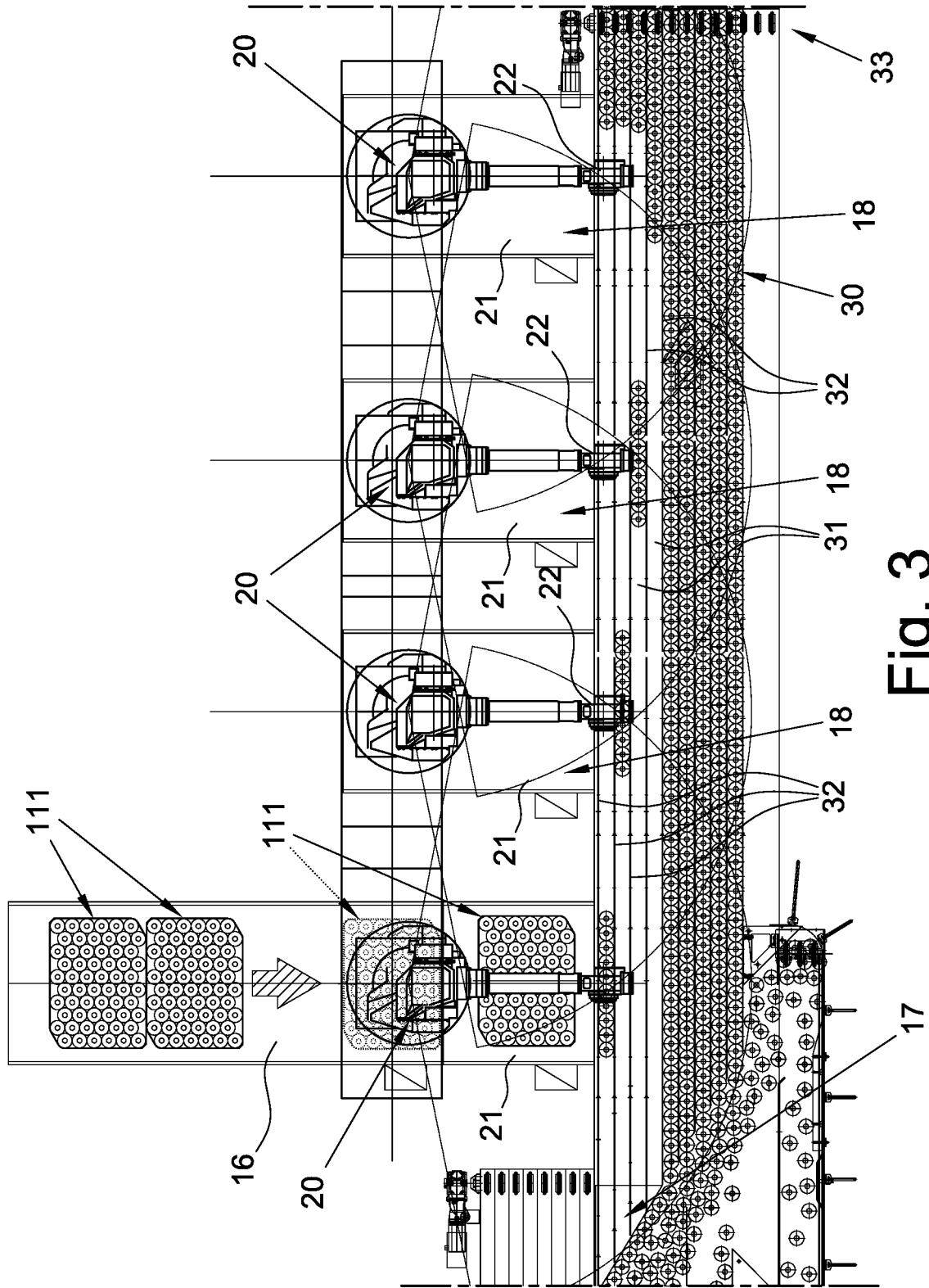

Fig. 3

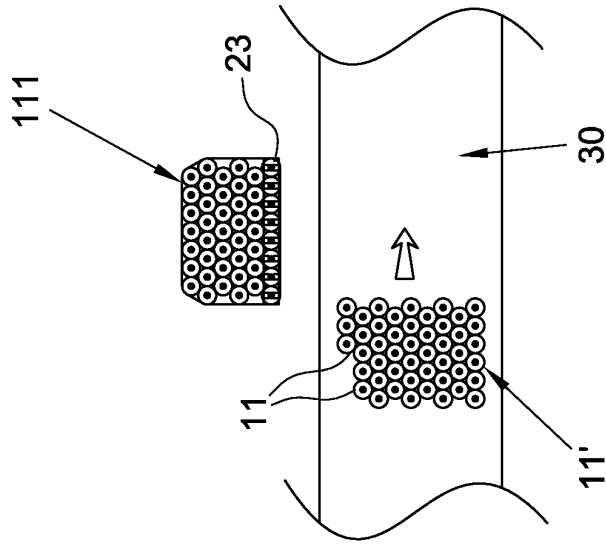

Fig. 4A

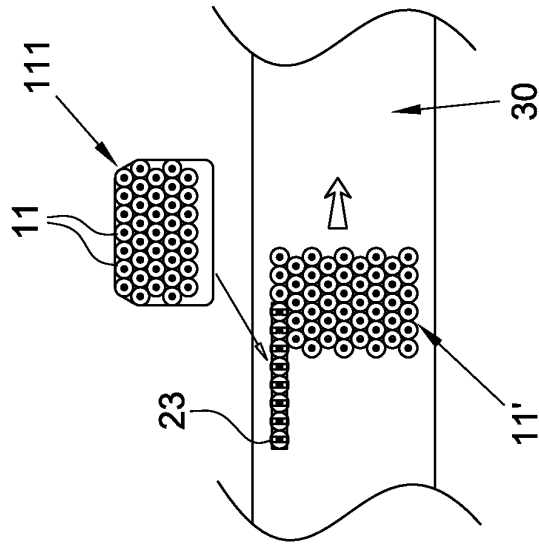

Fig. 4B

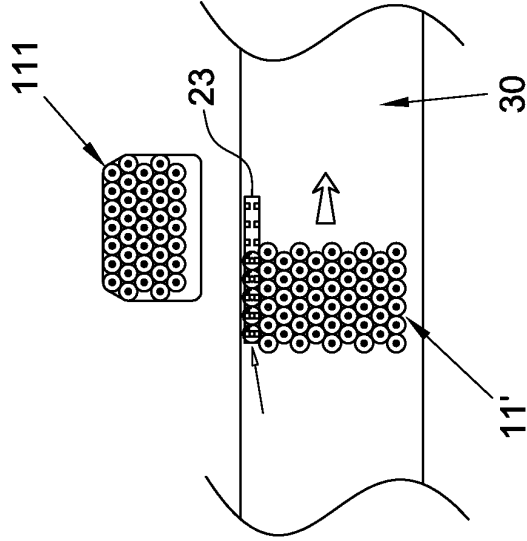

Fig. 4C

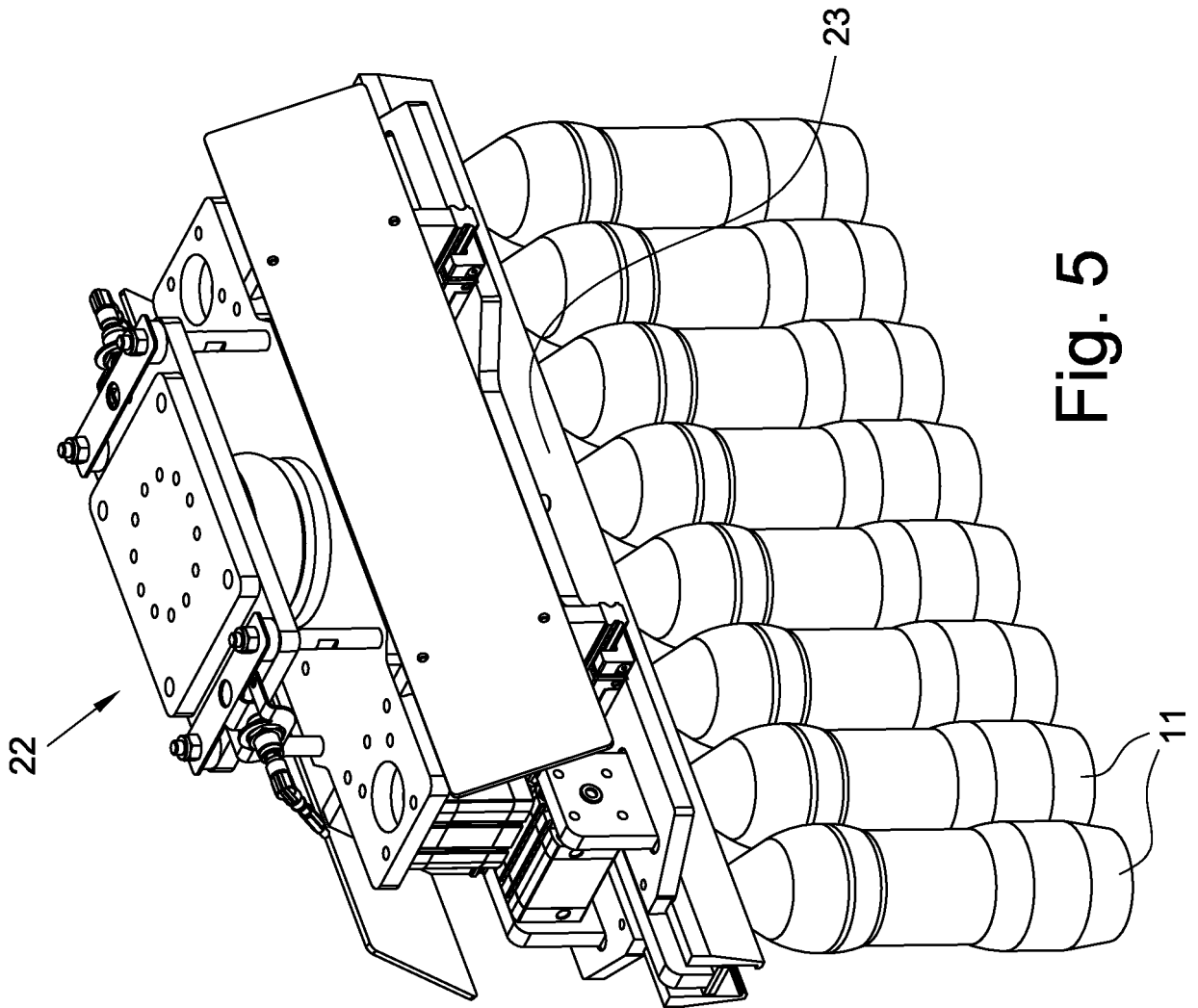

Fig. 5

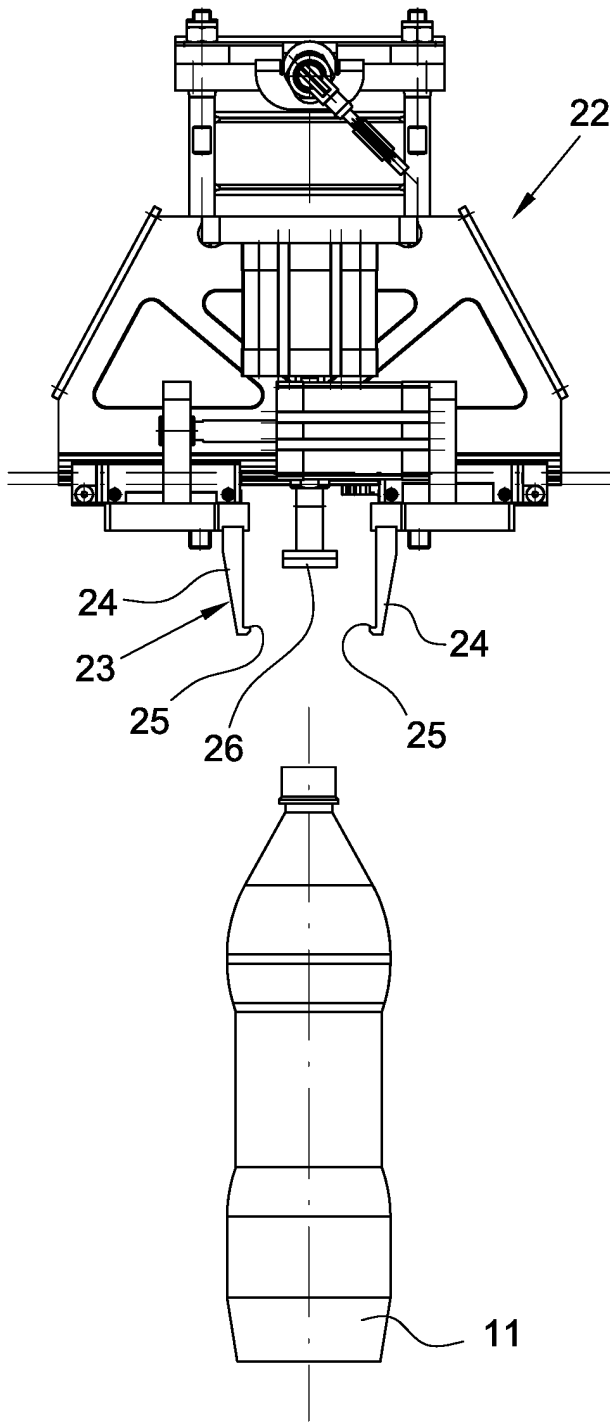

Fig. 6A

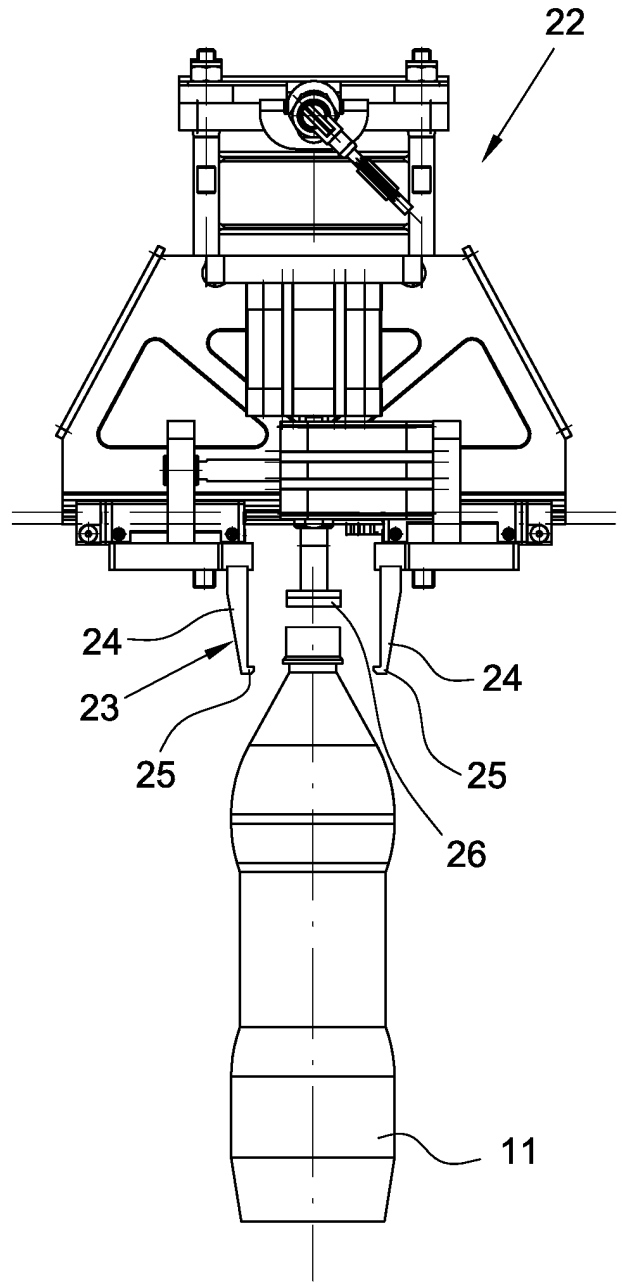

Fig. 6B

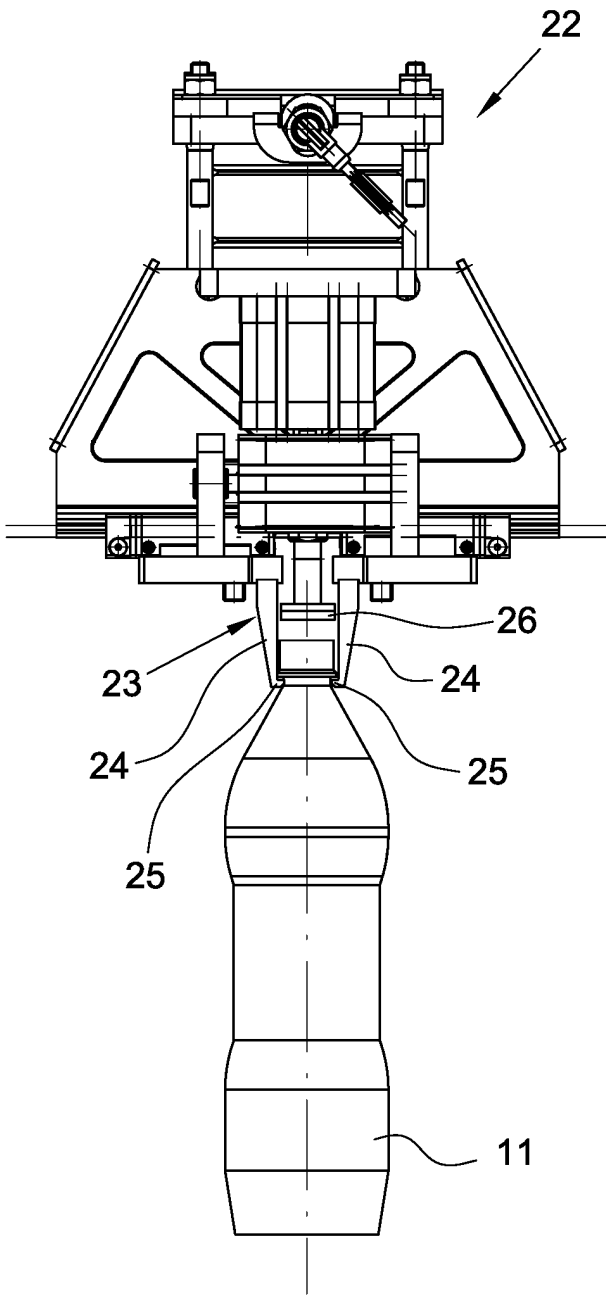

Fig. 6C

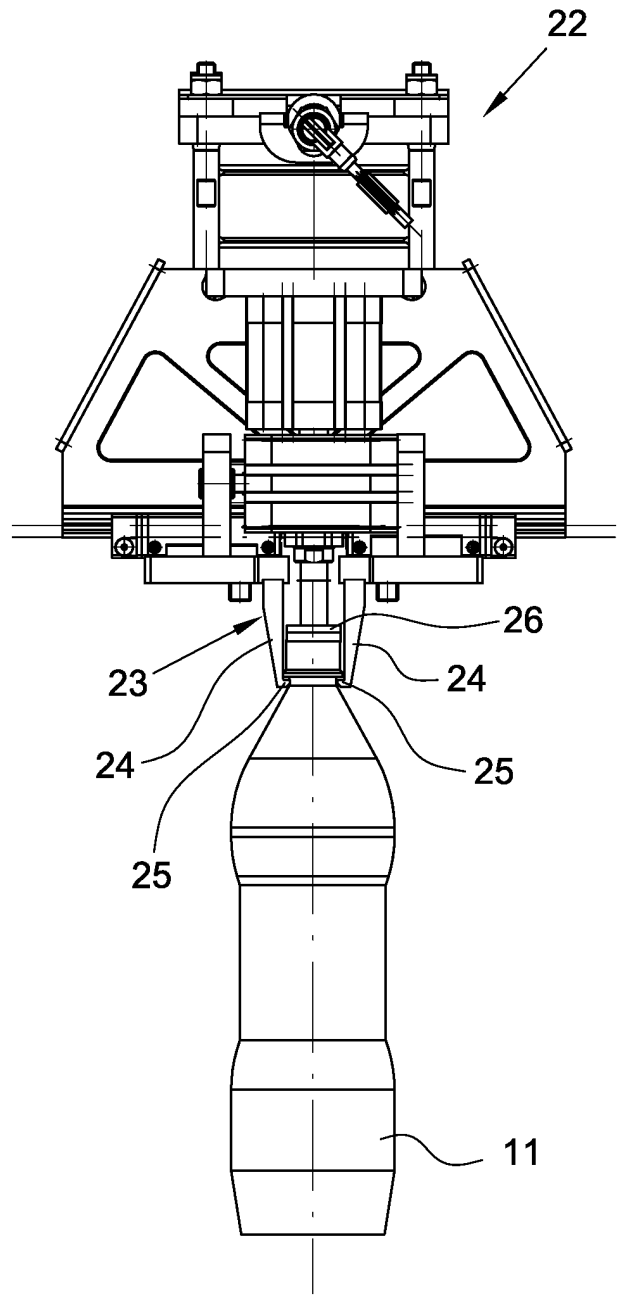

Fig. 6D

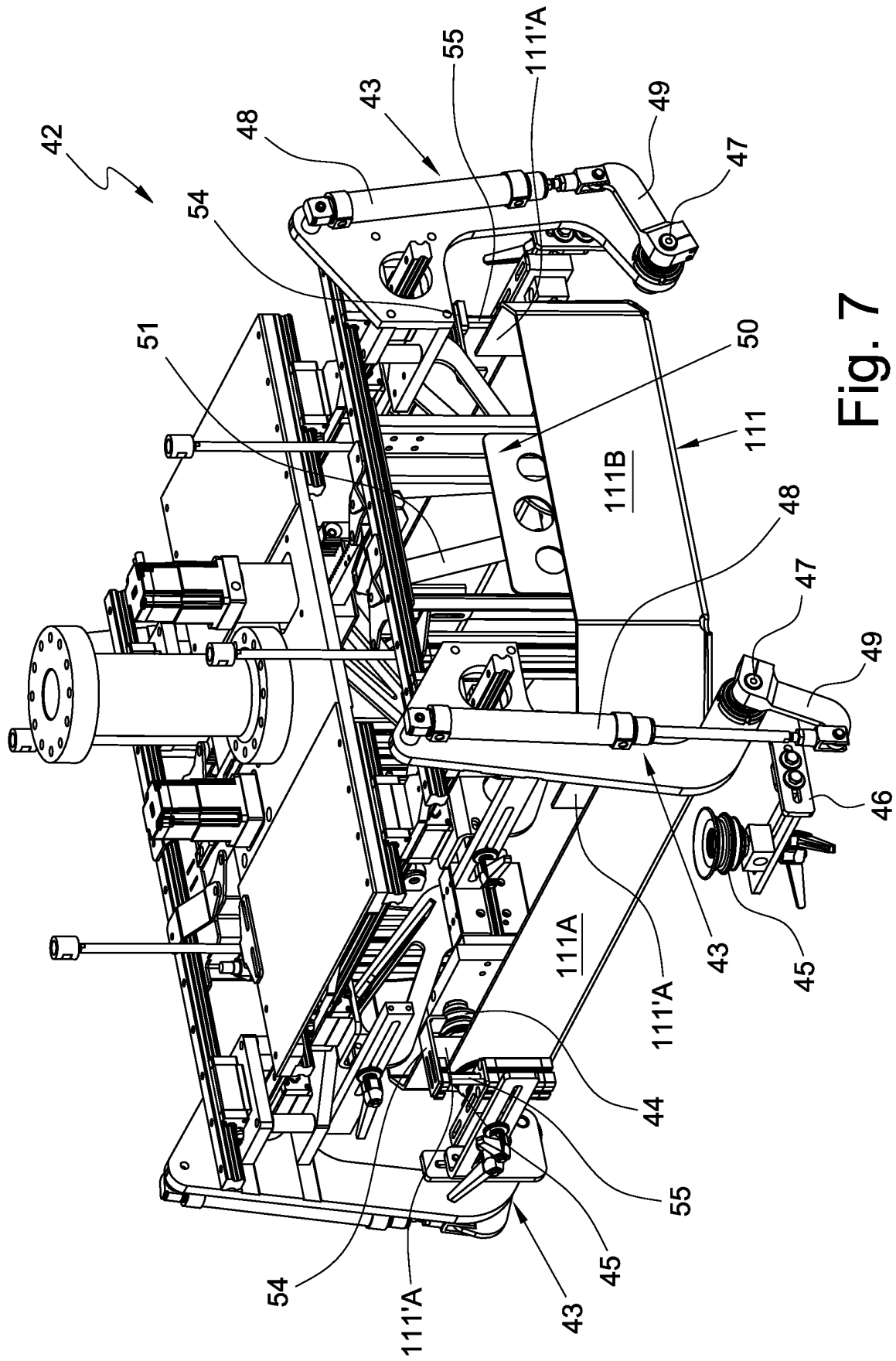

Fig. 7

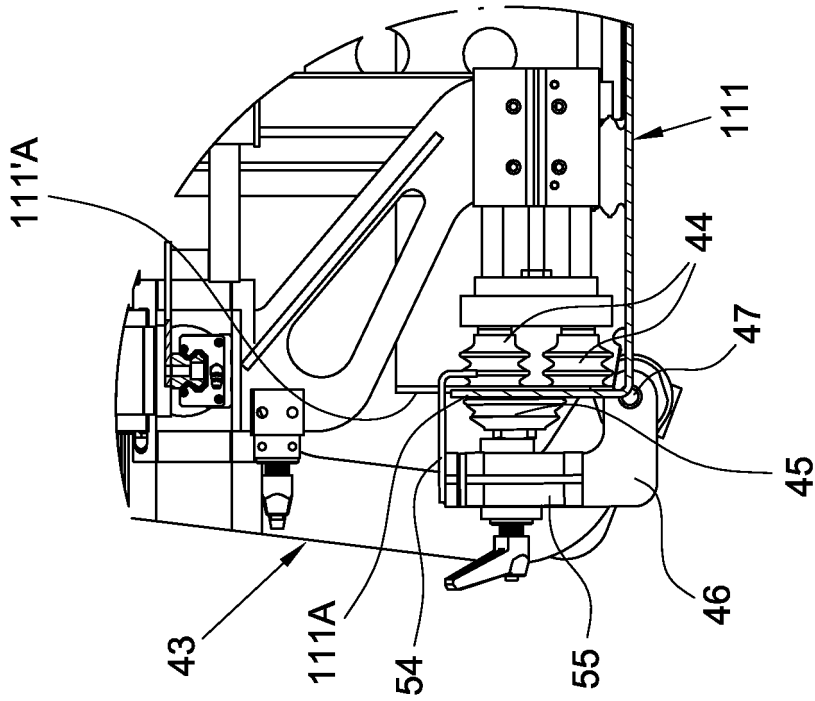

Fig. 8B

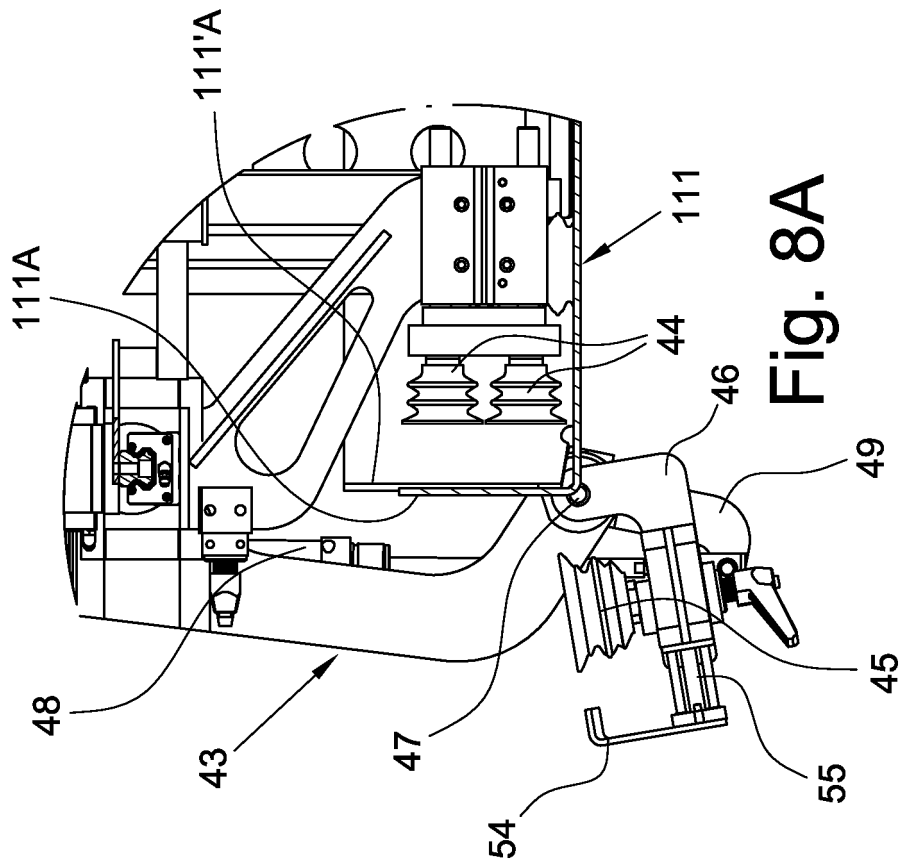
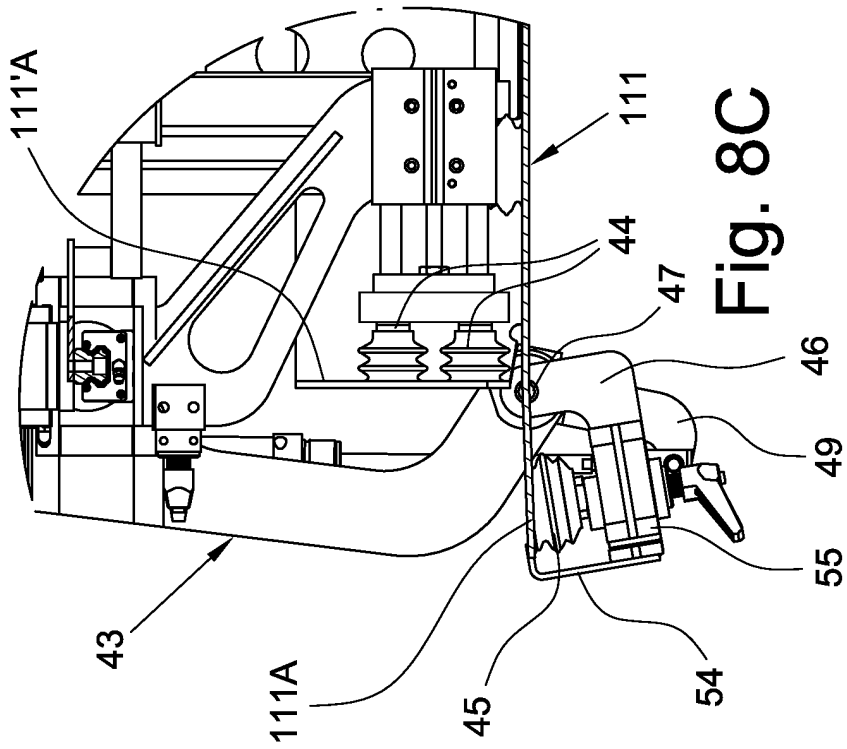
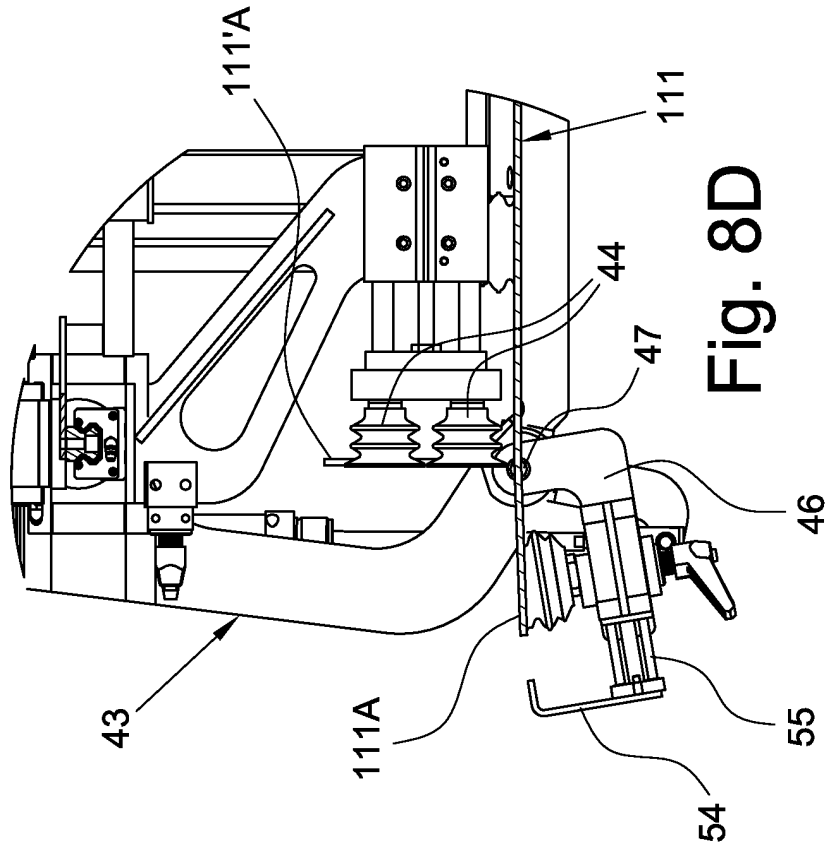

Fig. 8A



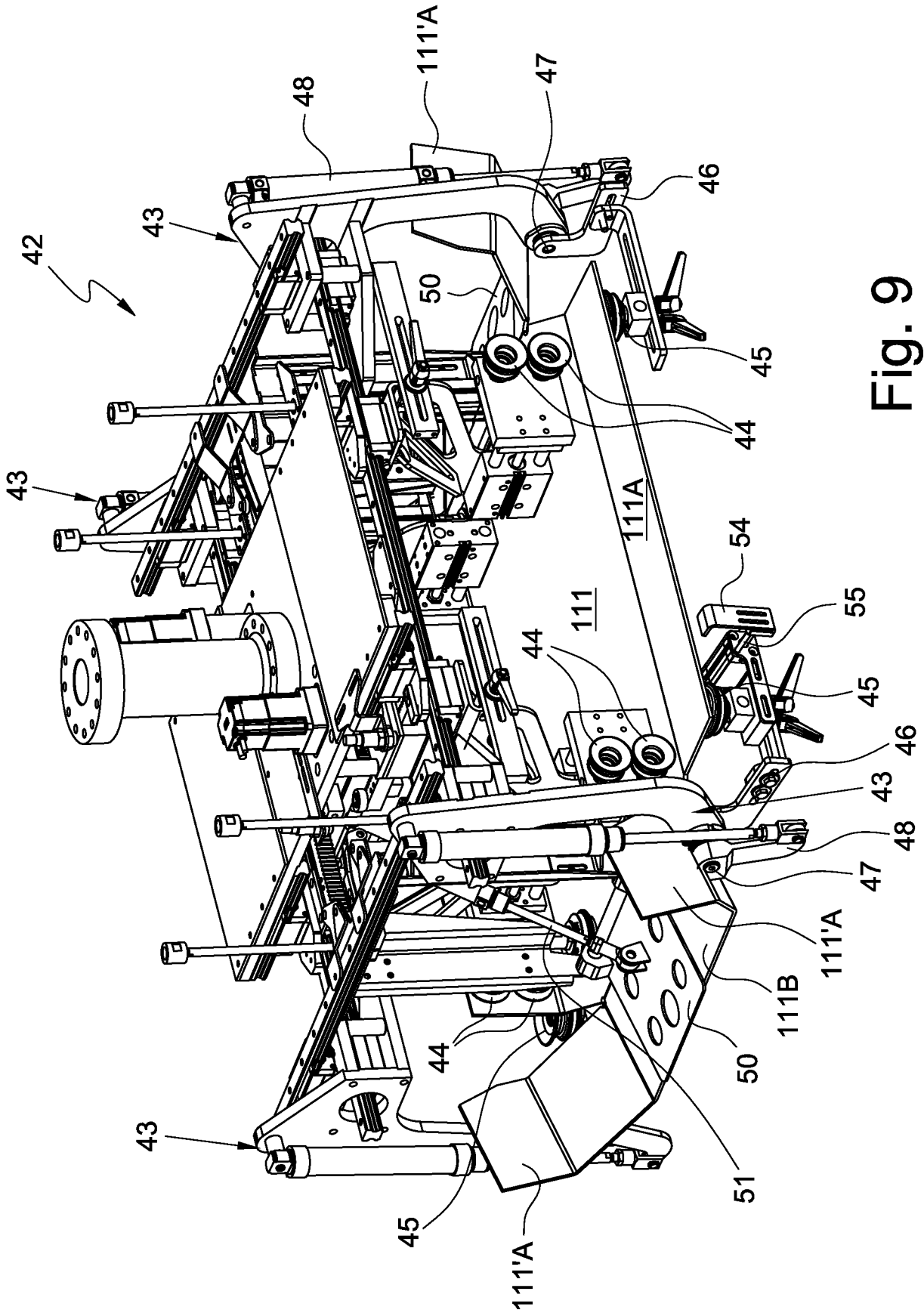

Fig. 9

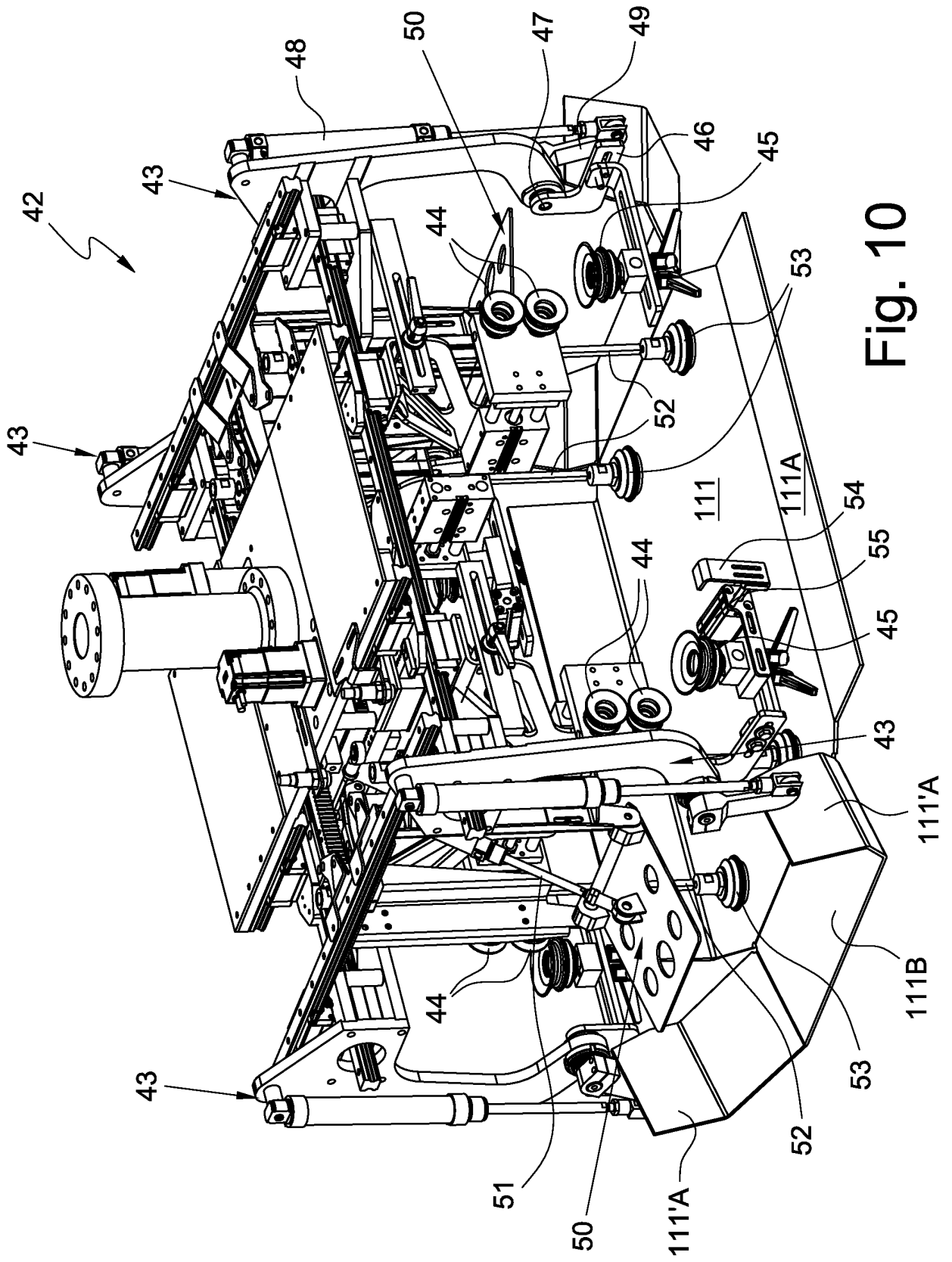

Fig. 10

REFERENCES CITED IN THE DESCRIPTION

This list of references cited by the applicant is for the reader's convenience only. It does not form part of the European patent document. Even though great care has been taken in compiling the references, errors or omissions cannot be excluded and the EPO disclaims all liability in this regard.

Patent documents cited in the description

- DE 202005019906 U1 [0012]