



- (51) International Patent Classification:
A61B 90/10 (2016.01) A61B 90/14 (2016.01)
- (21) International Application Number:
PCT/IB2019/001054
- (22) International Filing Date:
25 September 2019 (25.09.2019)
- (25) Filing Language: English
- (26) Publication Language: English
- (30) Priority Data:
62/736,057 25 September 2018 (25.09.2018) US
- (71) Applicant: **PRO MED INSTRUMENTS GMBH**
[DE/DE]; Boetzing Strasse 38, 79111 Freiburg im Breisgau (DE).
- (72) Inventors: **MERTENS, Jan, H.**; Sepp-Allgeier-Strasse 12, 79111 Freiburg (DE). **SCHUELE, Matthias, E.**; Besançonallee 1a, 79111 Freiburg (DE).

- (81) Designated States (unless otherwise indicated, for every kind of national protection available): AE, AG, AL, AM, AO, AT, AU, AZ, BA, BB, BG, BH, BN, BR, BW, BY, BZ, CA, CH, CL, CN, CO, CR, CU, CZ, DE, DJ, DK, DM, DO, DZ, EC, EE, EG, ES, FI, GB, GD, GE, GH, GM, GT, HN, HR, HU, ID, IL, IN, IR, IS, JO, JP, KE, KG, KH, KN, KP, KR, KW, KZ, LA, LC, LK, LR, LS, LU, LY, MA, MD, ME, MG, MK, MN, MW, MX, MY, MZ, NA, NG, NI, NO, NZ, OM, PA, PE, PG, PH, PL, PT, QA, RO, RS, RU, RW, SA, SC, SD, SE, SG, SK, SL, SM, ST, SV, SY, TH, TJ, TM, TN, TR, TT, TZ, UA, UG, US, UZ, VC, VN, ZA, ZM, ZW.
- (84) Designated States (unless otherwise indicated, for every kind of regional protection available): ARIPO (BW, GH, GM, KE, LR, LS, MW, MZ, NA, RW, SD, SL, ST, SZ, TZ, UG, ZM, ZW), Eurasian (AM, AZ, BY, KG, KZ, RU, TJ, TM), European (AL, AT, BE, BG, CH, CY, CZ, DE, DK, EE, ES, FI, FR, GB, GR, HR, HU, IE, IS, IT, LT, LU, LV, MC, MK, MT, NL, NO, PL, PT, RO, RS, SE, SI, SK, SM, TR), OAPI (BF, BJ, CF, CG, CI, CM, GA, GN, GQ, GW, KM, ML, MR, NE, SN, TD, TG).

(54) Title: HEAD STABILIZATION DEVICE WITH NON-UNIFORM PINS

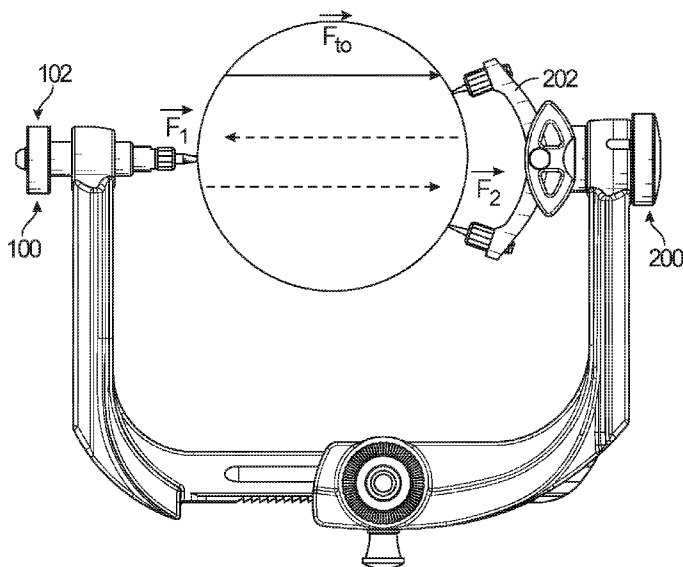

FIG. 6

(57) Abstract: A head stabilization device having the form of a skull clamp includes a first pin assembly and a second pin assembly. The pin assemblies are positioned opposite each other, and the first pin assembly has a first pin while the second pin assembly has a pair of pins. The pins used with the skull clamp are non-uniform. In this respect skull clamp can apply an equal force to a head of a patient from both sides. Additionally, the pressure at each pin location can be the same or substantially the same. This allows each of the pins to have the same or similar bone penetration when in use stabilizing the head of the patient.



WO 2020/065399 A1

Published:

- *with international search report (Art. 21(3))*
- *before the expiration of the time limit for amending the claims and to be republished in the event of receipt of amendments (Rule 48.2(h))*

- 1 -

HEAD STABILIZATION DEVICE WITH NON-UNIFORM PINS

PRIORITY

[0001] This application claims priority to U.S. Provisional Patent Application Serial No. 62/736,057, filed September 25, 2018, entitled “HEAD STABILIZATION DEVICE WITH NON-UNIFORM PINS,” the disclosure of which is incorporated by reference herein.

BACKGROUND

[0002] The devices and methods disclosed pertain to patient stabilization, and in particular head and neck stabilization using stabilization devices known as head stabilization devices which are also referred to as head fixation devices (hereinafter referred to as “HFDs” or “HFD” in singular). HFDs are sometimes used during a variety of surgical and other medical procedures, for example during head or neck surgery or testing where it would be desirable to securely hold a patient’s head in a certain position. While a variety of stabilization devices have been made and used, it is believed that no one prior to the inventor(s) has made or used an invention as described herein.

BRIEF DESCRIPTION OF THE DRAWINGS

[0003] While the specification concludes with claims which particularly point out and distinctly claim the invention, it is believed the present invention will be better understood from the following description of certain examples taken in conjunction with the accompanying drawings, in which like reference numerals identify the same elements.

[0004] FIG. 1 depicts a perspective view of an exemplary HFD.

[0005] FIG. 2 depicts a partial front view of a pin holder assembly of the HFD of FIG. 1, with the pin holder assembly configured to hold a single pin.

[0006] FIG. 3 depicts a partial front view of another pin holder assembly of the HFD of FIG. 1, with the pin holder assembly configured to hold a pair of pins.

- 2 -

[0007] FIG. 4 depicts an enlarged cross section view of a portion of the pin holder assembly of FIG. 2.

[0008] FIG. 5 depicts an enlarged cross section view of a portion of the pin holder assembly of FIG. 3.

[0009] FIG. 6 depicts an exemplary HFD including an overlay of an exemplary force distribution.

[00010] FIG. 7 depicts an imaging output showing pin penetration into a skull on the single pin side of an HFD.

[00011] FIG. 8 depicts an imaging output showing pin penetration into a skull on the 2-pin side of an HFD.

[00012] FIG. 9 depicts another exemplary pin usable with the HFD of FIG. 1.

[00013] FIG. 10 depicts another exemplary pin usable with the HFD of FIG. 1.

[00014] The drawings are not intended to be limiting in any way, and it is contemplated that various embodiments of the invention may be carried out in a variety of other ways, including those not necessarily depicted in the drawings. The accompanying drawings incorporated in and forming a part of the specification illustrate several aspects of the present invention, and together with the description serve to explain the principles of the invention; it being understood, however, that this invention is not limited to the precise arrangements shown.

DETAILED DESCRIPTION

[00015] The following description of certain examples of the invention should not be used to limit the scope of the present invention. Other examples, features, aspects, embodiments, and advantages of the invention will become apparent to those skilled in the art from the following description, which is by way of illustration, one of the best modes contemplated for carrying out the invention. As will be realized, the invention is capable of other different and obvious

- 3 -

aspects, all without departing from the invention. Accordingly, the drawings and descriptions should be regarded as illustrative in nature and not restrictive.

[00016] I. Exemplary HFD and Pin Configuration

[00017] FIG. 1 illustrates an exemplary HFD in the form of a skull clamp (10). While the present example illustrates the HFD as a U-shaped skull clamp, the teachings herein may be applied to other forms of HFDs as will be understood by those of ordinary skill in the art in view of the teachings herein. Skull clamp (10) comprises a first arm (12) and a second arm (14). First arm (12) is connectable with second arm (14) to form skull clamp (10) having a U-shape. First arm (12) comprises an upright portion (16) and a lateral portion (18). Similarly, second arm (14) comprises an upright portion (20) and a lateral portion (22). Skull clamp (10) is adjustable to accommodate a variety of head sizes by translating first arm (12) relative to second arm (14) or vice versa. Skull clamp (10) is further connectable to other structures, such as a positioning adapter or a base unit that is further connectable with an operating table, etc., by way of an attachment interface (24). As shown in the present example of FIG. 1, upright portion (16) of first arm (12) connects with a pin assembly (100), while upright portion (20) of second arm (14) connects with a pin assembly (200).

[00018] Referring now to FIG. 2, pin assembly (100) comprises a torque screw (102) configured to adjust an amount of clamping force skull clamp (10) applies to the head of the patient. Torque screw (102) comprises a wheel (104), a sleeve (106), a spring (not shown), and an elongated member (110). Sleeve (106) has a threaded outer surface that threadably engages with a threaded bore in upright portion (16) of arm (12). Sleeve (106) has an interior space where the spring is located. At a proximal end, the spring contacts wheel (104). At a distal end, the spring contacts a flange of elongated member (110). Wheel (104) is connected with sleeve (106) such that rotation of wheel (104) causes a corresponding rotation of sleeve (106). With this configuration, as wheel (104) is rotated, wheel (104) and sleeve (106) translate relative to upright portion (16) based on the threaded engagement depending on the direction of rotation of wheel (104).

- 4 -

[00019] Elongated member (110) extends through a bore in wheel (104) and elongated member (110) is secured to a screw (112) at its proximal end. At its distal end, elongated member (110) retains a pin holder (114) that retains a pin (116). In use, at least a distal tip (118) of pin (116) contacts the head of the patient. When wheel (104) is rotated, such that wheel (104) and sleeve (106) translate distally towards the patient's head between pin assemblies (100, 200), the spring is compressed and thereby exerts increased force on elongated member (110) in a direction toward the patient's head. Because elongated member (110) retains pin holder (114), which retains pin (116), this increase in force on elongated member (110) coincides with an increase in force at pin (116), which contacts the patient's head. Force applied by pin (116) to the head of the patient can be decreased by rotation of wheel (104) in the opposite direction.

[00020] Referring to FIG. 3, pin assembly (200) connects with upright portion (20) of arm (14) as shown. In the present example, this connection between pin assembly (200) and upright portion (20) is such that the lateral position of pin assembly (200) relative to upright portion (20) of arm (14), is fixed once the pivot position is set as discussed below. Pin assembly (200) comprises rocker arm (202), which retains pin holders (204), which in turn retain pins (206) configured to contact the head of the patient. Rocker arm (202) is rotatably adjustable about an axis B1 extending through a bore in upright portion (20). This rotation can be selectively controlled such that the rotatable position of rocker arm (202) can be locked in position or unlocked for adjustment. In view of the teachings herein, various ways to configure pin assembly (200) to provide locking and unlocking states for rotational adjustment will be apparent to those of ordinary skill in the art. Pin assembly (200) is also configured such that rocker arm (202) is pivotably adjustable about an axis B4 defined longitudinally by pin (214). Regardless of the rotational or pivotal adjustments, the force applied to the head of the patient via torque screw (102) of pin assembly (100) as described above, causes force to also be applied to the head of the patient from pin assembly (200) and its pins (206) that are configured to contact the head of the patient.

[00021] With the configuration described above for skull clamp (10), the head of a patient can be stabilized. By way of example only, and not limitation, in a stabilization procedure for an

- 5 -

adult head, the force applied by pin assembly (100) can be between about 270 newtons and about 360 newtons. However, the precise amount of force used should be gauged according to a given surgeon's needs taking into consideration such things as the procedure type, the patient's bone structure and condition, etc. In some examples, the precise amount of force used may be an amount such that pin (116) and pins (206) anchor in the bone of the skull, but without penetrating the entire way through the bone. Again, the example force range provided above, as well as anywhere else, is merely exemplary and should not be interpreted as limits or limiting in any fashion. Accordingly, it should be understood that in some other examples the stabilization force used can be greater or less than the range presented above of between about 270 newtons and 360 newtons.

[00022] Referring to FIG. 6, torque screw (102) is configured in some versions with a gage or scale that indicates the total force applied, which denoted \vec{F}_{Σ} . In an example where 360 newtons of force is applied as indicated by the scale on torque screw (102), this force is applied to both sides by pin assemblies (100, 200) as shown as \vec{F}_1 for the force applied by pin assembly (100), and \vec{F}_2 for the force applied by pin assembly (200). In an ideal setup with a perfectly round patient head, and with one skull pin on each side where the skull pins have a common longitudinal axis, \vec{F}_1 and \vec{F}_2 would each be 360 newtons. In this manner equal and opposite forces would be applied to the sides of the head of the patient. In 3-pin configurations using single pin (116) with pin assembly (100) and a pair of pins (206) with rocker arm (202) with pin assembly (200), the force distribution differs because the force applied by pair of pins (206) is divided between each pin (206) of the pair. Accordingly, in a simplified example the 360 newtons of force for \vec{F}_2 is divided equally between each pin (206) of the pair, such that each pin (206) applies 180 newtons of force when single pin (116) applies 360 newtons of force as indicated on the scale or gage of torque screw (102). In this example, the force applied on each side of the head of the patient is equal at 360 newtons.

[00023] The force applied to the head of the patient is an important variable in terms of the ultimate pressure applied at the head of the patient where the pins contact the head. Pressure is directly related to the applied force by the relationship that pressure P equals force F divided by

- 6 -

area A as shown in Equation 1.

[00024] Equation 1

[00025] $P = F/A$

[00026] In looking at skull clamp (10), the pressure at the side with pin assembly (100) would be calculated as the force \vec{F}_1 divided by the area. In this case, the area on the side with pin assembly (100), area A_1 , is equal to the contact area provided by pin (116) with the head of the patient. The pressure at the side with pin assembly (200) could be calculated similarly as the force \vec{F}_2 divided by the area. On the 2-pin side, the force \vec{F}_2 is split between the two pins (206) as mentioned above. Furthermore, each pin (206) has an associated area A_2 . So, the pressure on the 2-pin side where each pin (206) contacts the head of the patient equals half of the force \vec{F}_2 divided by the contact area A_2 provided by pin (206).

[00027] With skull clamp configurations using a 3-pin setup where one pin assembly has a single pin and the other pin assembly has a pair of pins, using the same configuration for each pin provides that the contact area where each pin contacts the head of the patient will be the same; thus $A_1 = A_2$. However, because the force \vec{F}_2 on the 2-pin side is split between two pins, the pressure where each pin on the 2-pin side contacts the head will be lower compared to the pressure where the single pin on the 1-pin side contacts the head. This difference in pressure can lead to different penetration depths of the pins in the skull bone as illustrated in the example of FIGS. 7 and 8 that show a CT scan of a skull clamp using uniform pin configurations for all pin locations. As seen in FIG. 7, the pin on the single pin side has penetrated too deep, breaching the skull bone. As seen in FIG.8, the pair of pins on the 2-pin side hardly penetrate the skull bone. This pressure imbalance and its impact on skull bone penetration by the pins can compromise the rigidity or integrity of the patient's head stabilization.

[00028] Returning to skull clamp (10) with pin assemblies (100, 200) and pin (116) and pins (206), the present illustrated example of FIGS. 1-5 uses pins having differing configurations to achieve uniform or more uniform pressure at each location where one of pins (116, 206) contacts

the patient's head for stabilization. For instance, in some versions it is desirable to configure skull clamp (10) such that in use, each pin (206) of pin assembly (200) generates a pressure that equals the pressure generated by single pin (116) of pin assembly (100). In the illustrated version described further below, this is achieved by using pins having different pin angles thereby altering the contact areas to influence the pressure according to the equations above. In some other versions, it can be desirable to configure skull clamp (10) such that in use, the pin of pin assembly (100) generates a pressure that equals the pressure generated by each pin (206) of pin assembly (200).

[00029] In one example, pin assembly (100) has single pin (116) with a contact area A_1 . Furthermore, in the present example the contact area of each pin (206) used on the 2-pin side is one-half of the contact area A_1 on the single pin side. Knowing, as explained above, that force $\vec{F}_2 = \text{force } \vec{F}_1$, and that force \vec{F}_2 on the 2-pin side is split between two pins (206), the pressure at each of pins (206) can be represented as shown in Equation 2 below.

[00030] Equation 2

[00031] Pressure at Each Pin (206) = (Force $\vec{F}_1 / 2$) / ($A_1 / 2$)

[00032] Equation 2 can be simplified to Equation 3 below, which is the same equation for calculating the pressure at pin (116).

[00033] Equation 3

[00034] Pressure at Pin (116) = Force \vec{F}_1 / A_1

[00035] Thus, by reducing the contact area for pins (206) on the 2-pin side, the pressure at pins (206) is increased to match the pressure at pin (116) on the single pin side. This uniform pressure profile or distribution provides for uniform bone penetration at each location where pins (116, 206) contact the head of the patient, which in turn promotes a more rigid and secure stabilization. This also provides the ability to avoid excessive pressure use on the single pin side when trying to achieve acceptable bone penetration on the 2-pin side, thereby reducing trauma to

the patient. Moreover, the uniform pressure distribution mentioned above is achieved by maintaining the same force applied to each side of the head of the patient.

[00036] Referring now to FIG. 4, pin (116) is shown in cross section, and defines a longitudinal axis LA1 extending through pin (116). Furthermore, pin (116) comprises a body portion (120) and a tapered portion (122). Pin (116) further defines an axis B2, which extends from distal tip (118) proximally along pin (116). The intersection of longitudinal axis LA1 and axis B2 define a pin angle α_1 .

[00037] Referring now to FIG. 5, pin (206) is shown in cross section, and defines a longitudinal axis LA2 extending through pin (206). Furthermore, pin (206) comprises a body portion (208) and a tapered portion (210). Pin (206) further defines an axis B3, which extends from a distal tip (212) proximally along pin (206). The intersection of longitudinal axis LA2 and axis B3 define a pin angle α_2 .

[00038] With the configuration for skull clamp (10) having a single pin (116) on one side and a pair of pins (206) on the opposite side, as shown in FIGS. 4 and 5, the pin angles differ. That is, pin (116) has a pin angle of α_1 , and pins (206) each have a pin angle of α_2 , and pin angle α_1 does not equal pin angle α_2 . In one version of skull clamp (10), pins (206) have a pin angle α_2 that is smaller than the pin angle α_1 of pin (116). In some examples, the first pin angle and the second pin angle are each within the range of about 3 degrees to about 45 degrees. In some other versions this range can be about 3 degrees to about 23 degrees. In some versions of skull clamp (10), the pin angle α_2 of pins (206) on the 2-pin side is greater than or equal to about 1 degree smaller than the pin angle α_1 of pin (116) on the single pin side. Still in other examples of skull clamp (10), the difference in pin angle α_1 , α_2 of pins (206) and pin (116) can be larger or smaller than 1 degree. Also, the about 1 degree difference stated in the above example is non-limiting and merely one example of a difference in pin angle α_1 , α_2 of pins (206) and pin (116). For instance, in some versions of skull clamp (10) the pin angle α_2 of pins (206) on the 2-pin side is greater than or equal to about 5 degrees smaller than the pin angle α_1 of pin (116) on the single pin side. In another example, the difference in pin angle α_1 , α_2 of pins (206) and pin

(116) is such that the pin angle α_2 of pins (206) is about half of the pin angle α_1 of pin (116). In another version of skull clamp (10), the pin angle α_1 of pin (116) and the pin angle α_2 of pins (206) are each within the range of about 3 degrees to about 45 degrees with the difference between the pin angle α_1 and the pin angle α_2 is at least about 1 degree. In another version of skull clamp (10), the pin angle α_1 of pin (116) and the pin angle α_2 of pins (206) are each within the range of about 3 degrees to about 23 degrees with the difference between the pin angle α_1 and the pin angle α_2 is at least about 1 degree. Still yet, in another version of skull clamp (10), the pin angle α_2 of pins (206) on the 2-pin side is between about 1 degree and about 5 degrees smaller than the pin angle α_1 of pin (116) on the single pin side.

[00039] With the smaller pin angle α_2 , the contact area for pin (206) is less and therefore the force applied to and through pins (206) is applied over a smaller contact area which in turn increases the pressure. For example, with the conical shape of pins (116, 206), the contact area or surface area can be represented by Equation 4 below, where A = surface area; r = radius of the cone; and h = height of the cone.

[00040] Equation 4

[00041]
$$A = \pi r(r + \sqrt{h^2 + r^2})$$

[00042] As the pin angle decreases, the radius decreases and thus the surface area decreases. Conversely, with larger pin angles, the radius is greater and thus the surface area is greater. As shown above, these surface areas correlate with the contact area of the pins and this directly impacts pressure applied by the pins to the head of the patient.

[00043] Another way area or contact area can be assessed is by considering the circular area of the pin in cross section at a given penetration depth relative to the skull bone. In some versions of skull clamp (10), this circular area of pins (206) on the 2-pin side is less than or smaller than this circular area of pin (116) on the single pin side. In some versions of skull clamp (10), this circular area of pins (206) on the 2-pin side is less than or equal to 0.6 times smaller than this circular area of pin (116) on the single pin side. In other versions of skull

- 10 -

clamp (10) the magnitude of the difference in cross sectional circular areas of pins (206) compared with pin (116) can be greater or less than the example above having 0.6 times smaller circular area. In some versions of skull clamp (10), this circular area of pins (206) on the 2-pin side is about half of this circular area of pin (116) on the single pin side.

[00044] In some versions of skull clamp (10), pins (206) on the 2-pin side are different in shape compared with pin (116) on the single pin side; thus the pins (116, 206) are not uniform in this respect. In view of the teachings herein, other ways to characterize pins (116, 206), pin angles, contact areas, etc. will be apparent to those of ordinary skill in the art. Accordingly, the examples above should be considered non-exhaustive and non-limiting.

[00045] Referring now to FIGS. 9 and 10, alternate exemplary pins (316, 416) are shown that can be used in place of any of the pins of skull clamp (10) and pin assemblies (100, 200). In one example, pin (316) or pin (416) is used instead of pin (116). Furthermore, pins (316, 416) illustrate examples having larger pin angles (α_3 , α_4). In the present examples of FIGS. 9 and 10, pin angles (α_3 , α_4) are about 45 degrees; however, in other versions pin angles can be more or less than about 45 degrees.

[00046] Pin angles (α_3 , α_4) are defined in the same manner as described above with respect to pin angles (α_1 , α_2). More specifically, pin (316) is shown in cross section in FIG. 9, and defines a longitudinal axis LA3 extending through pin (316). Furthermore, pin (316) comprises a body portion (320) and a tapered portion (322). Pin (316) further defines an axis B5, which extends from distal tip (318) proximally along pin (316). The intersection of longitudinal axis LA3 and axis B5 define a pin angle α_3 .

[00047] Similarly, pin (416) is shown in cross section in FIG. 10, and defines a longitudinal axis LA4 extending through pin (416). Furthermore, pin (416) comprises a body portion (420) and a tapered portion (422). Pin (416) further defines an axis B6, which extends from distal tip (418) proximally along pin (416). The intersection of longitudinal axis LA4 and axis B6 define a pin angle α_4 .

- 11 -

[00048] When replacing pin (116) with either pin (316) or pin (416) that have larger pin angles (α_3 , α_4), the result can be that skull clamp (10) is configured such that in use, the pin (316, 416) of pin assembly (100) generates a pressure that equals the pressure generated by each pin (206) of pin assembly (200). For instance, one way to match pressures is to decrease the pin angle on the 2-pin side, while another way to match pressures is to increase the pin angle on the single pin side. Using pins (316, 416) in place of pin (116) takes this latter approach, whereas using pins (206) on the 2-pin side instead of using all pins configured like pin (116) takes the former approach to matching pressures. Still yet, in view of the teachings herein, those of ordinary skill in the art will appreciate other ways to modify the pins on one or both sides of the patient's head to achieve a uniform or more uniform pressure application.

[00049] Still referring to FIGS. 9 and 10, while each pin (316, 416) has a pin angle of about 45 degrees as defined above, pin (416) has a geometry with a larger conical shaped portion compared to pin (316). In terms of the contact area calculation from Equation 4 above, this translates to pin (416) having a larger radius of the cone portion and a larger height of the cone portion. This means that pin (416) can provide for greater contact surface area as pins (316, 416) penetrate the skull bone. In this manner the force applied when using pin (416) can be distributed over a larger area and thus provide a lower pressure. It should be noted here that in use the larger contact area for pin (416) provides a difference over pin (316) when the penetration of the pins (316, 416) is such that pins (316, 416) penetrate deeper than the cone shape or cone height of pin (316). In view of the teachings herein, other ways to influence contact area based on parameters like shape configuration will be apparent to those of ordinary skill in the art.

[00050] II. Exemplary Combinations

[00051] The following examples relate to various non-exhaustive ways in which the teachings herein may be combined or applied. It should be understood that the following examples are not intended to restrict the coverage of any claims that may be presented at any time in this application or in subsequent filings of this application. The following examples are being provided for nothing more than merely illustrative purposes. It is contemplated that the various

teachings herein may be arranged and applied in numerous other ways. It is also contemplated that some variations may omit certain features referred to in the below examples.

[00052] Example 1

[00053] A device for stabilizing a head of a patient during a medical procedure, wherein the device comprises: (a) a first pin assembly having a first pin configured to engage a skull of the patient to stabilize the head of the patient, wherein the first pin comprises a first pin angle; and (b) a second pin assembly having a pair of pins configured to engage the skull of the patient to stabilize the head of the patient, wherein each pin of the pair of pins comprises a second pin angle different than the first pin angle of the first pin.

[00054] Example 2

[00055] The device of Example 1, wherein the first pin assembly and the second pin assembly are configured to be positioned on opposite sides of the head of the patient.

[00056] Example 3

[00057] The device of any one or more of Examples 1 through 2, wherein a longitudinal cross section of the first pin defines the first pin angle by an intersection of a longitudinal axis of the single pin with an axis of the single pin extending from a distal tip of the single pin proximally along the single pin; and wherein a longitudinal cross section of each pin of the pair of pins defines the second pin angle by an intersection of a longitudinal axis of each respective pin of the pair of pins with an axis of each respective pin of the pair of pins extending from a distal tip of each respective pin of the pair of pins proximally along each respective pin of the pair of pins.

[00058] Example 4

[00059] The device of any one or more of Examples 1 through 3, wherein the second pin angle is smaller than the first pin angle.

[00060] Example 5

[00061] The device of any one or more of Examples 1 through 4, wherein the first pin angle and the second pin angle are configured such that a pressure exerted on the head of the patient when stabilized is substantially equal where the first pin and the pair of pins each contact the head of the patient.

[00062] Example 6

[00063] The device of any one or more of Examples 1 through 5, wherein the first pin angle and the second pin angle are configured such that the first pin and the pair of pins each have a substantially equal bone penetration depth when stabilizing the head of the patient.

[00064] Example 7

[00065] The device of any one or more of Examples 1 through 6, wherein the device comprises a skull clamp having a first arm and a second arm that are selectively and adjustably connectable, wherein the first arm comprises a first upright portion connected with a first lateral portion, wherein the second arm comprises a second upright portion connected with a second lateral portion, wherein the first pin assembly connects with the first upright portion, and wherein the second pin assembly connects with the second upright portion.

[00066] Example 8

[00067] The device of any one or more of Examples 1 through 7, wherein the first pin angle and the second pin angle are each within the range of about 3 degrees to about 23 degrees with the difference between the first pin angle and the second pin angle is at least about 1 degree.

[00068] Example 9

[00069] The device of any one or more of Examples 1 through 8, wherein the first pin angle and the second pin angle are each within the range of about 3 degrees to about 45 degrees with the difference between the first pin angle and the second pin angle is at least about 1 degree.

[00070] Example 10

- 14 -

[00071] The device of any one or more of Examples 1 through 9, wherein the first pin assembly comprises a force adjustment feature configured to adjust an amount of force applied by the first pin to the head of the patient, wherein the amount of force applied by the first pin when stabilizing the head of the patient is between about 270 newtons and about 360 newtons.

[00072] Example 11

[00073] The device of any one or more of Examples 1 through 10, wherein a force applied by each pin of the pair of pins when stabilizing the head of the patient is between about 135 newtons and about 180 newtons.

[00074] Example 12

[00075] The device of any one or more of Examples 1 through 11, wherein the second pin angle of each pin of the pair of pins is greater than or equal to about 1 degree smaller than the first pin angle of the first pin.

[00076] Example 13

[00077] The device of any one or more of Examples 1 through 11, wherein the second pin angle of each pin of the pair of pins is between about 1 degree and about 5 degrees smaller than the first pin angle of the first pin.

[00078] Example 14

[00079] A device for stabilizing a head of a patient during a medical procedure, wherein the device comprises two or more pin assemblies, wherein each of the pin assemblies comprises at least one pin configured to engage a skull of the patient to stabilize the head of the patient, wherein the at least one pin of a select one of the two or more pin assemblies comprises a first pin angle, and wherein the at least one pin of another select one of the two or more pin assemblies comprises a second pin angle, wherein the first pin angle and the second pin angle differ.

[00080] Example 15

[00081] A device for stabilizing a head of a patient during a medical procedure, wherein the device comprises (a) a first pin assembly having a single pin configured to engage a skull of the patient to stabilize the head of the patient; and (b) a second pin assembly having a pair of pins configured to engage the skull of the patient to stabilize the head of the patient, wherein the pair of pins and the single pin are non-uniform.

[00082] Example 16

[00083] The device of Example 15, wherein the pair of pins are different in shape compared with single pin.

[00084] Example 17

[00085] A device for stabilizing a head of a patient during a medical procedure, wherein the device comprises (a) a first pin assembly having a single pin configured to engage a skull of the patient to stabilize the head of the patient, wherein the first pin comprises a first tapered portion having a first conical shape with a first radius; and (b) a second pin assembly having a pair of pins configured to engage the skull of the patient to stabilize the head of the patient, wherein the pair of pins each comprise a second tapered portion having a second conical shape with a second radius, wherein the second radius is smaller than the first radius.

[00086] Example 18

[00087] The device of Example 17, wherein the contact area of each pin of the pair of pins is less than the contact area of the single pin when the device is used to stabilize the head of the patient.

[00088] Example 19

[00089] The device of any one or more of Examples 17 through 18, wherein the single pin comprises a first circular area in cross section at a first penetration depth, and wherein each pin

of the pair of pins comprises a second circular area in cross section at the first penetration depth.

[00090] Example 20

[00091] The device Example 19, wherein the second circular area is smaller than the first circular area.

[00092] III. Miscellaneous

[00093] It should be understood that any one or more of the teachings, expressions, embodiments, examples, etc. described herein may be combined with any one or more of the other teachings, expressions, embodiments, examples, etc. that are described herein. The following-described teachings, expressions, embodiments, examples, etc. should therefore not be viewed in isolation relative to each other. Various suitable ways in which the teachings herein may be combined will be readily apparent to those of ordinary skill in the art in view of the teachings herein. Such modifications and variations are intended to be included within the scope of the claims.

[00094] Having shown and described various embodiments of the present invention, further adaptations of the methods and systems described herein may be accomplished by appropriate modifications by one of ordinary skill in the art without departing from the scope of the present invention. Several of such potential modifications have been mentioned, and others will be apparent to those skilled in the art. For instance, the examples, embodiments, geometrics, materials, dimensions, ratios, steps, and the like discussed above are illustrative and are not required. Accordingly, the scope of the present invention should be considered in terms of the following claims and is understood not to be limited to the details of structure and operation shown and described in the specification and drawings.

I/We Claim:

1. A device for stabilizing a head of a patient during a medical procedure, wherein the device comprises:

(a) a first pin assembly having a first pin configured to engage a skull of the patient to stabilize the head of the patient, wherein the first pin comprises a first pin angle; and

(b) a second pin assembly having a pair of pins configured to engage the skull of the patient to stabilize the head of the patient, wherein each pin of the pair of pins comprises a second pin angle different than the first pin angle of the first pin.

2. The device of claim 1, wherein the first pin assembly and the second pin assembly are configured to be positioned on opposite sides of the head of the patient.

3. The device of claim 1, wherein a longitudinal cross section of the first pin defines the first pin angle by an intersection of a longitudinal axis of the first pin with an axis of the first pin extending from a distal tip of the first pin proximally along the first pin; and wherein a longitudinal cross section of each pin of the pair of pins defines the second pin angle by an intersection of a longitudinal axis of each respective pin of the pair of pins with an axis of each respective pin of the pair of pins extending from a distal tip of each respective pin of the pair of pins proximally along each respective pin of the pair of pins.

4. The device of claim 1, wherein the second pin angle is smaller than the first pin angle.

5. The device of claim 1, wherein the first pin angle and the second pin angle are configured such that a pressure exerted on the head of the patient when stabilized is substantially equal where the first pin and the pair of pins each contact the head of the patient.

6. The device of claim 1, wherein the first pin angle and the second pin angle are configured such that the first pin and the pair of pins each have a substantially equal bone

- 18 -

penetration depth when stabilizing the head of the patient.

7. The device of claim 1, wherein the device comprises a skull clamp having a first arm and a second arm that are selectively and adjustably connectable, wherein the first arm comprises a first upright portion connected with a first lateral portion, wherein the second arm comprises a second upright portion connected with a second lateral portion, wherein the first pin assembly connects with the first upright portion, and wherein the second pin assembly connects with the second upright portion.

8. The device of claim 1, wherein the first pin angle and the second pin angle are each within the range of about 3 degrees to about 23 degrees with the difference between the first pin angle and the second pin angle is at least about 1 degree.

9. The device of claim 1, wherein the first pin angle and the second pin angle are each within the range of about 3 degrees to about 45 degrees with the difference between the first pin angle and the second pin angle is at least about 1 degree.

10. The device of claim 1, wherein the first pin assembly comprises a force adjustment feature configured to adjust an amount of force applied by the first pin to the head of the patient, wherein the amount of force applied by the first pin when stabilizing the head of the patient is between about 270 newtons and about 360 newtons.

11. The device of claim 10, wherein a force applied by each pin of the pair of pins when stabilizing the head of the patient is between about 135 newtons and about 180 newtons.

12. The device of claim 1, wherein the second pin angle of each pin of the pair of pins is greater than or equal to about 1 degree smaller than the first pin angle of the first pin.

13. The device of claim 1, wherein the second pin angle of each pin of the pair of pins is between about 1 degree and about 5 degrees smaller than the first pin angle of the first pin.

14. A device for stabilizing a head of a patient during a medical procedure, wherein the device comprises two or more pin assemblies, wherein each of the pin assemblies comprises

- 19 -

at least one pin configured to engage a skull of the patient to stabilize the head of the patient, wherein the at least one pin of a select one of the two or more pin assemblies comprises a first pin angle, and wherein the at least one pin of another select one of the two or more pin assemblies comprises a second pin angle, wherein the first pin angle and the second pin angle differ.

15. A device for stabilizing a head of a patient during a medical procedure, wherein the device comprises:

(a) a first pin assembly having a single pin configured to engage a skull of the patient to stabilize the head of the patient; and

(b) a second pin assembly having a pair of pins configured to engage the skull of the patient to stabilize the head of the patient, wherein the pair of pins and the single pin are non-uniform.

16. The device of claim 15, wherein the pair of pins are different in shape compared with single pin.

17. A device for stabilizing a head of a patient during a medical procedure, wherein the device comprises:

(a) a first pin assembly having a single pin configured to engage a skull of the patient to stabilize the head of the patient, wherein the first pin comprises a first tapered portion having a first conical shape with a first radius; and

(b) a second pin assembly having a pair of pins configured to engage the skull of the patient to stabilize the head of the patient, wherein the pair of pins each comprise a second tapered portion having a second conical shape with a second radius, wherein the second radius is smaller than the first radius.

18. The device of claim 17, wherein the contact area of each pin of the pair of pins is less than the contact area of the single pin when the device is used to stabilize the head of the

- 20 -

patient.

19. The device of claim 17, wherein the single pin comprises a first circular area in cross section at a first penetration depth, and wherein each pin of the pair of pins comprises a second circular area in cross section at the first penetration depth.

20. The device of claim 19, wherein the second circular area is smaller than the first circular area.

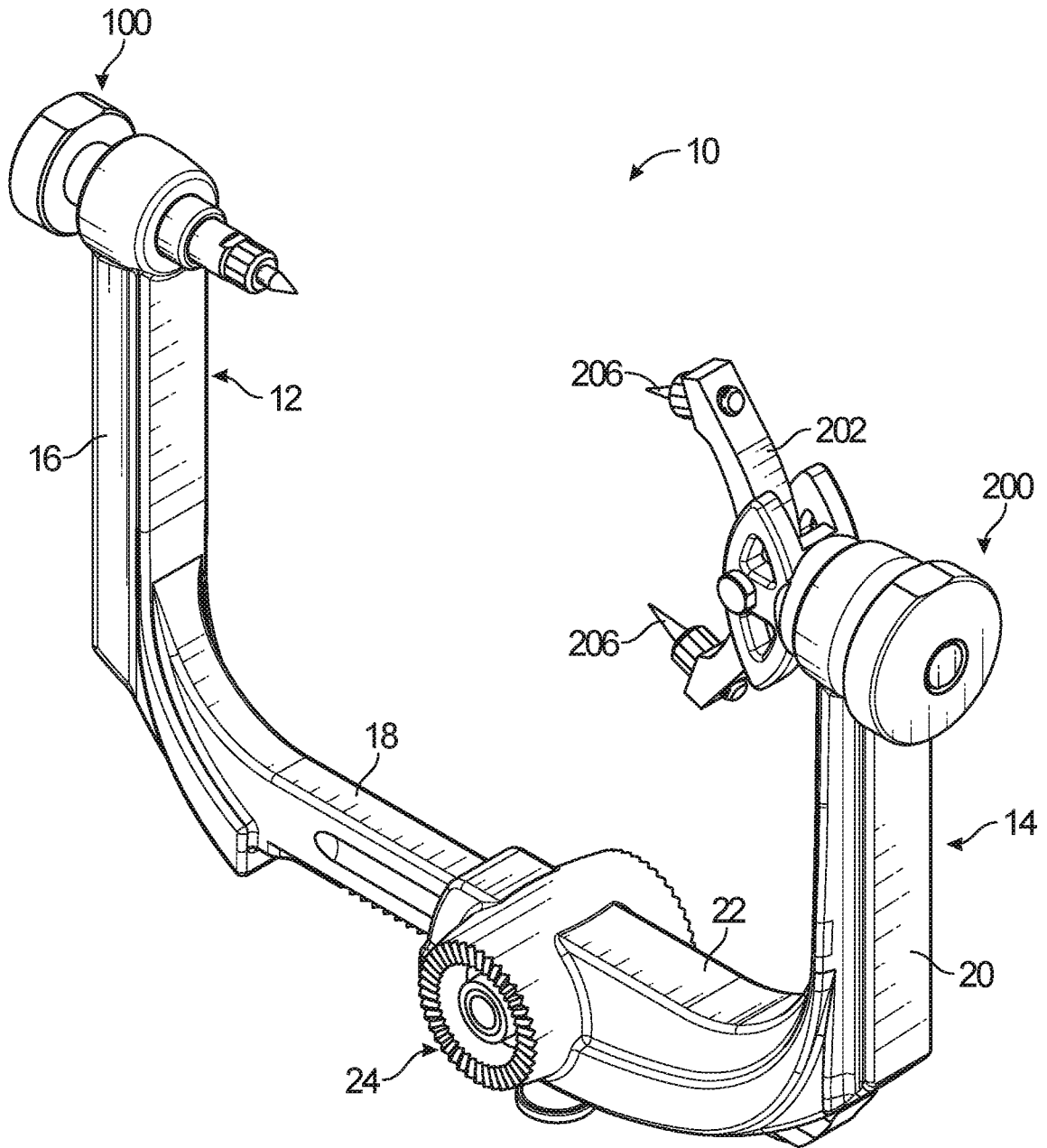

FIG. 1

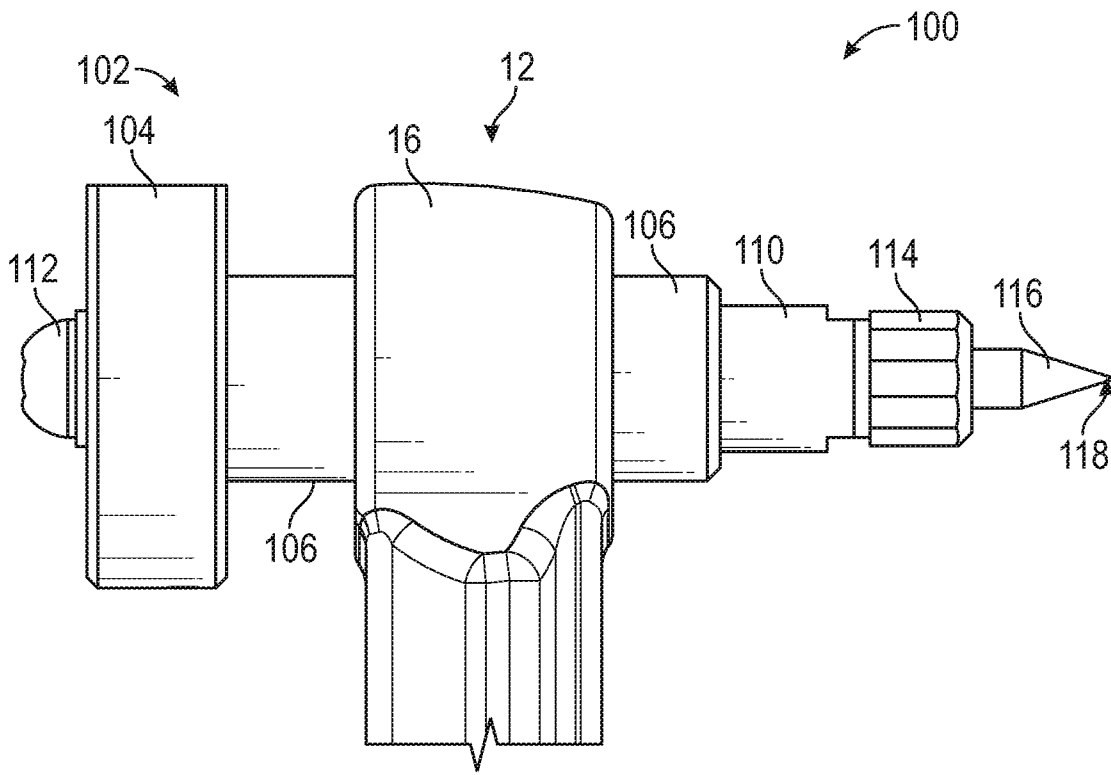

FIG. 2

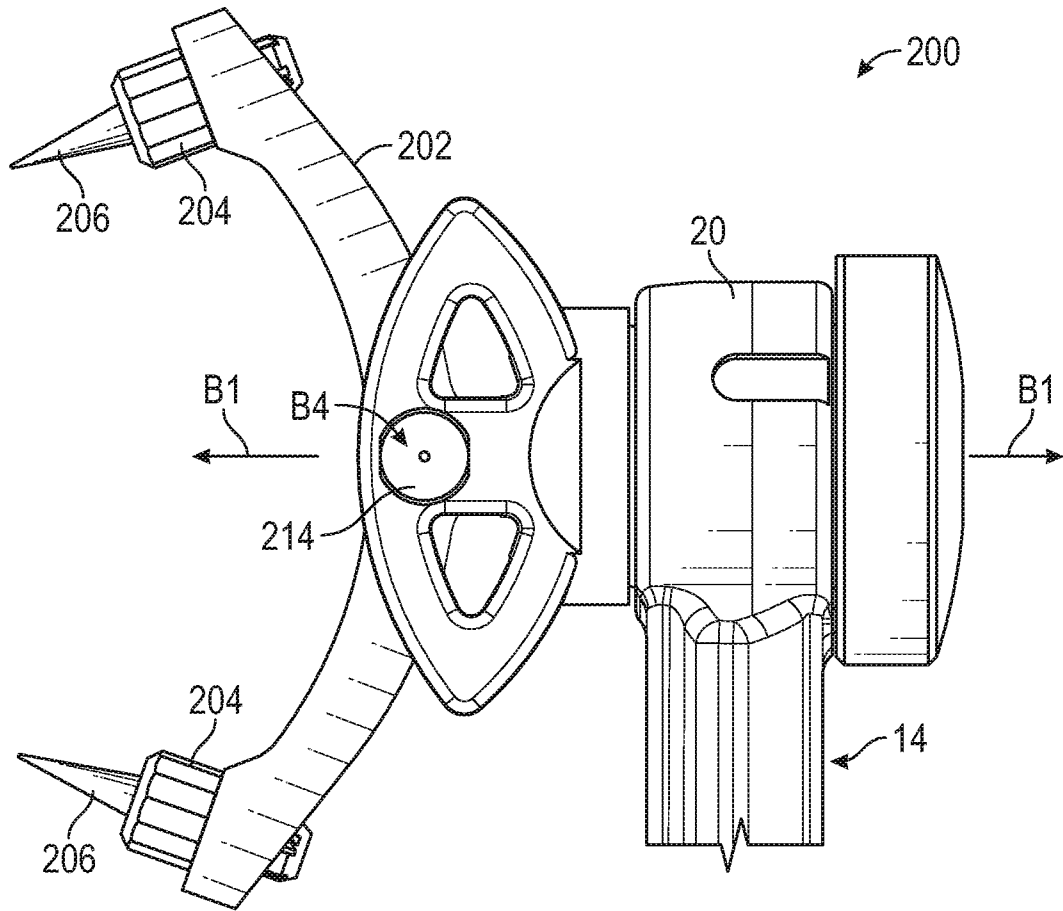

FIG. 3

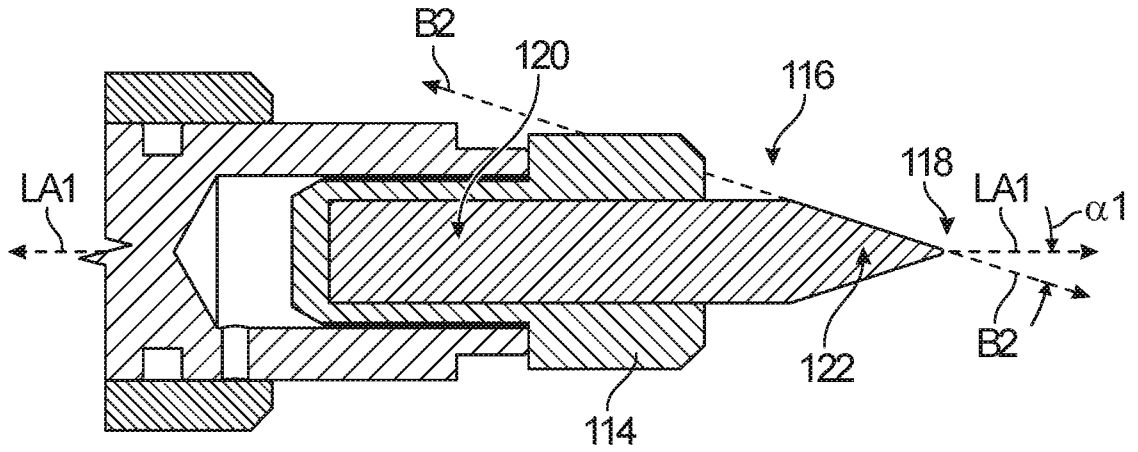

FIG. 4

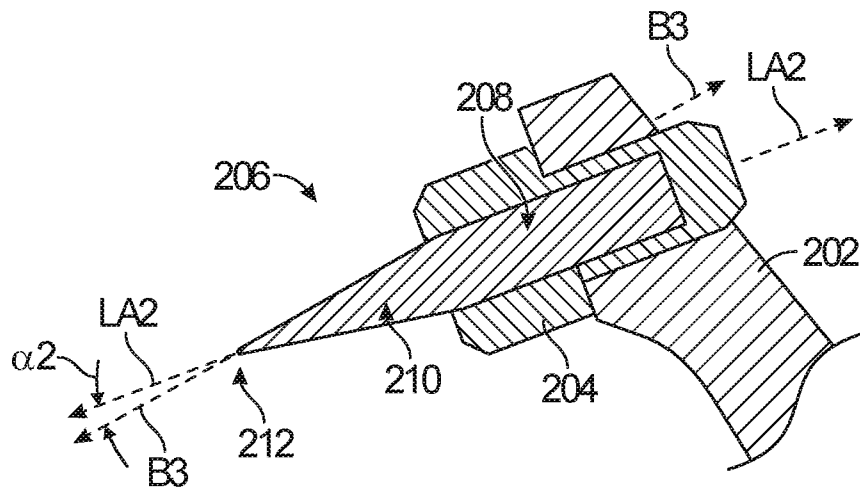

FIG. 5

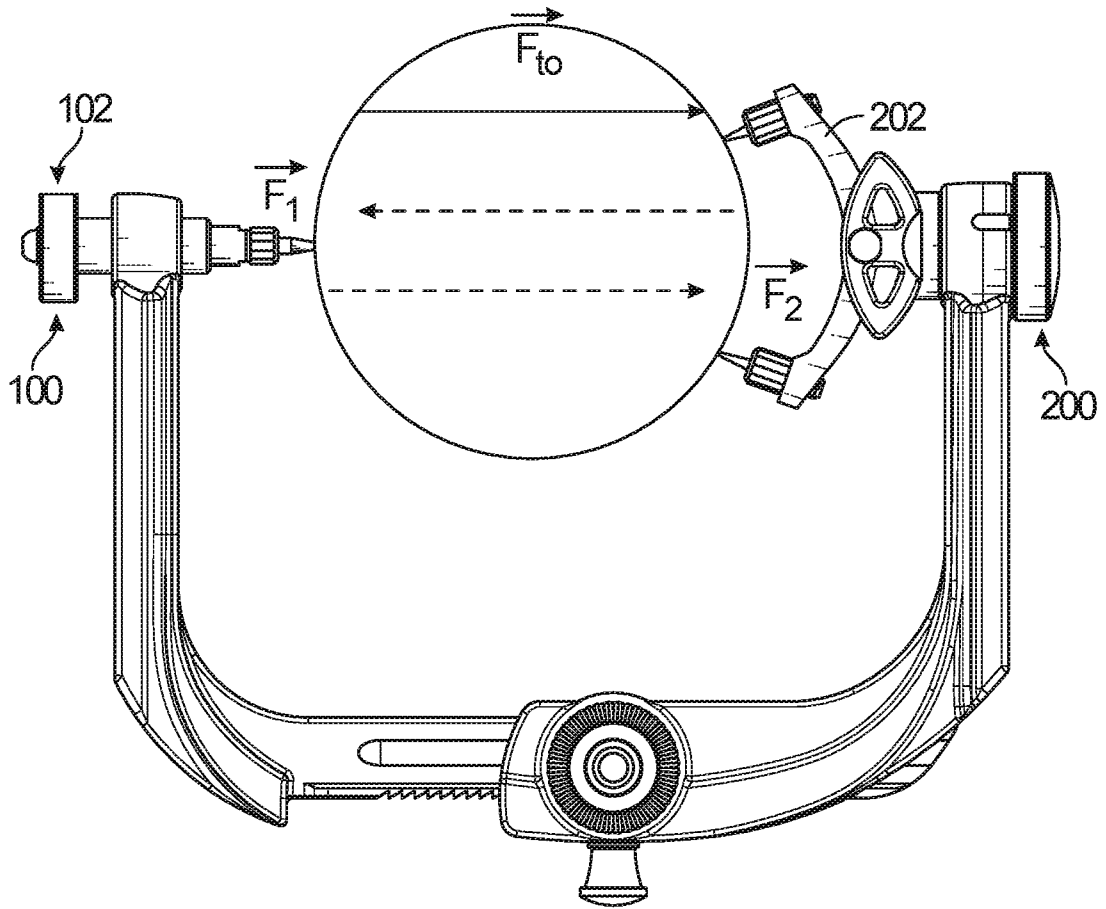

FIG. 6

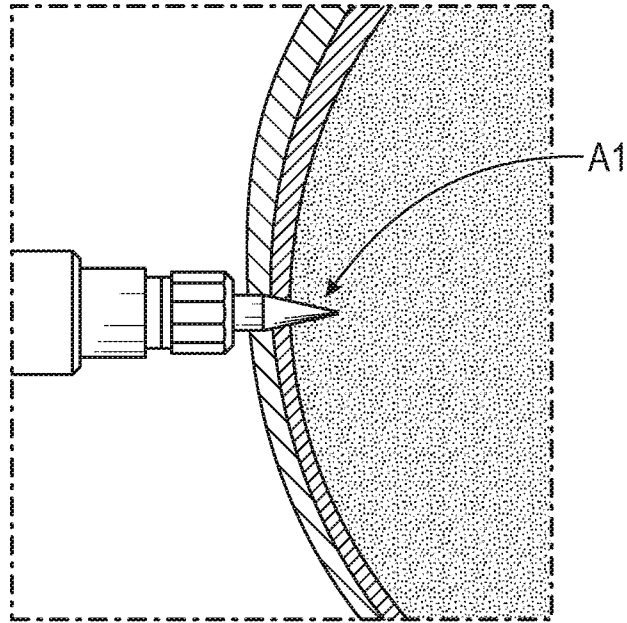

FIG. 7

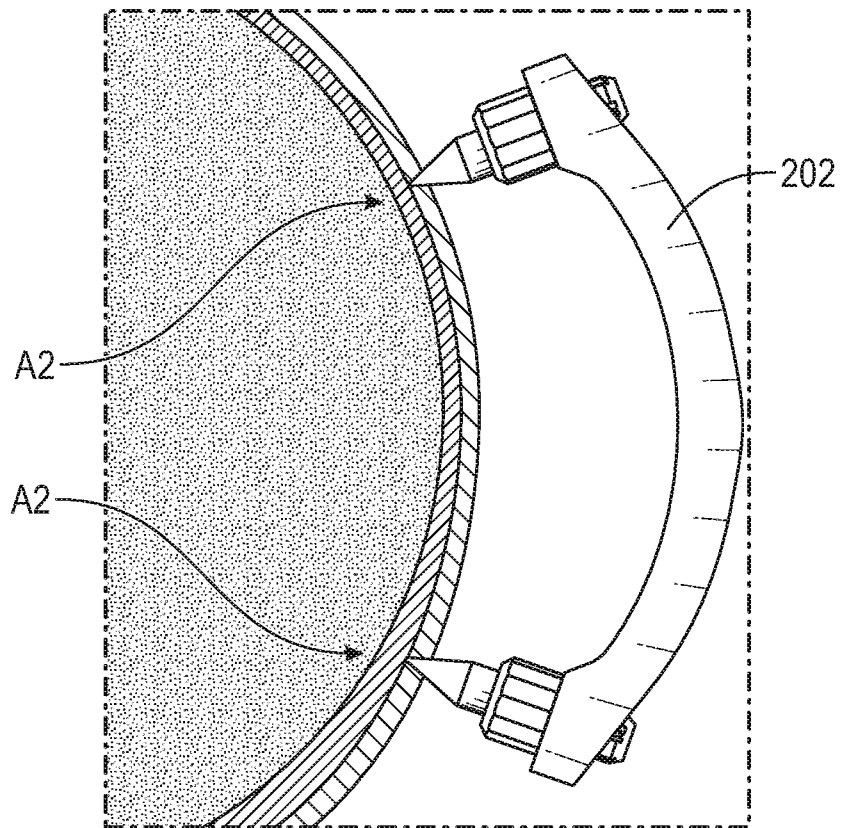

FIG. 8

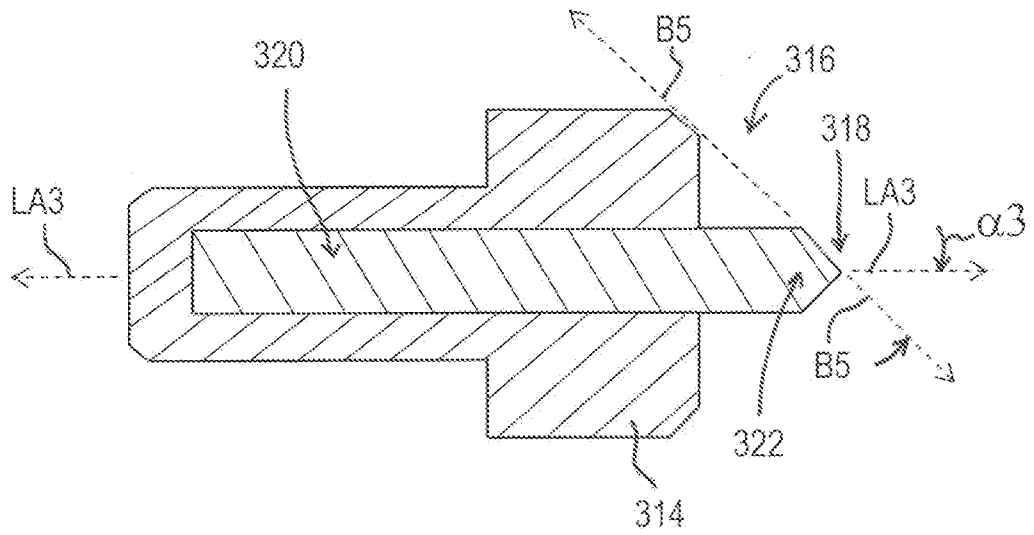

FIG. 9

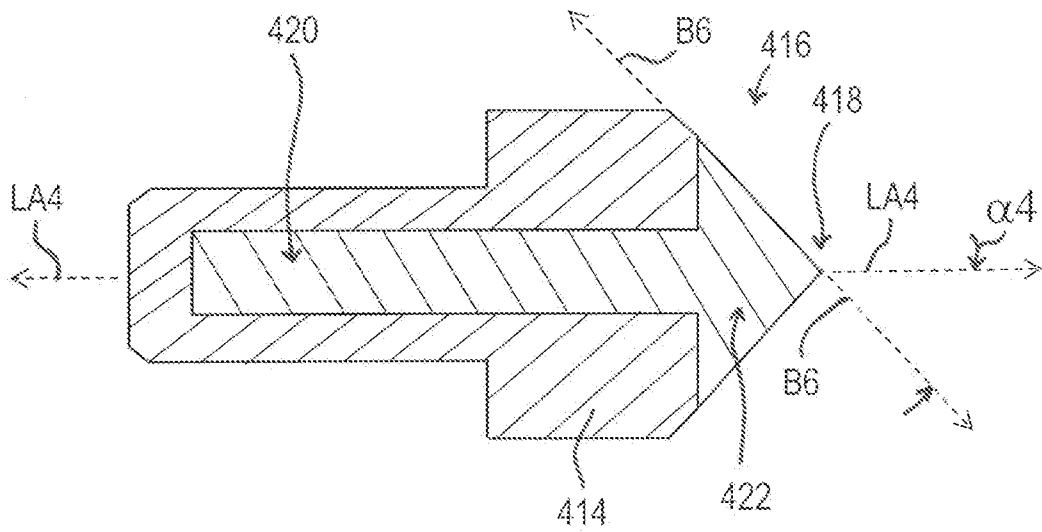

FIG. 10

INTERNATIONAL SEARCH REPORT

International application No
PCT/IB2019/001054

A. CLASSIFICATION OF SUBJECT MATTER
INV. A61B90/10 A61B90/14
ADD.
According to International Patent Classification (IPC) or to both national classification and IPC

B. FIELDS SEARCHED
Minimum documentation searched (classification system followed by classification symbols)
A61B

Documentation searched other than minimum documentation to the extent that such documents are included in the fields searched

Electronic data base consulted during the international search (name of data base and, where practicable, search terms used)
EPO-Internal, WPI Data

C. DOCUMENTS CONSIDERED TO BE RELEVANT

Category*	Citation of document, with indication, where appropriate, of the relevant passages	Relevant to claim No.
X Y A	WO 99/29252 A1 (DEPUY ACE MEDICAL COMPANY [US]) 17 June 1999 (1999-06-17) figures 1,5	1-4,14, 15 9-11 5-8,12, 13,16-20
X A	----- US 7 730 563 B1 (SKLAR FREDERICK [US] ET AL) 8 June 2010 (2010-06-08) figure 2	1,5-8, 12-20 2-4,9-11
Y	----- US 2002/042618 A1 (TWEARDY LISA A G [CH]) 11 April 2002 (2002-04-11) paragraph [0018]	9
Y	----- EP 2 014 251 A1 (BRAINLAB AG [DE]) 14 January 2009 (2009-01-14) paragraph [0052]; figure 6G -----	10,11

Further documents are listed in the continuation of Box C.

See patent family annex.

* Special categories of cited documents :

- "A" document defining the general state of the art which is not considered to be of particular relevance
- "E" earlier application or patent but published on or after the international filing date
- "L" document which may throw doubts on priority claim(s) or which is cited to establish the publication date of another citation or other special reason (as specified)
- "O" document referring to an oral disclosure, use, exhibition or other means
- "P" document published prior to the international filing date but later than the priority date claimed

- "T" later document published after the international filing date or priority date and not in conflict with the application but cited to understand the principle or theory underlying the invention
- "X" document of particular relevance; the claimed invention cannot be considered novel or cannot be considered to involve an inventive step when the document is taken alone
- "Y" document of particular relevance; the claimed invention cannot be considered to involve an inventive step when the document is combined with one or more other such documents, such combination being obvious to a person skilled in the art
- "&" document member of the same patent family

Date of the actual completion of the international search

20 January 2020

Date of mailing of the international search report

28/01/2020

Name and mailing address of the ISA/

European Patent Office, P.B. 5818 Patentlaan 2
NL - 2280 HV Rijswijk
Tel. (+31-70) 340-2040,
Fax: (+31-70) 340-3016

Authorized officer

Milles, Julien

INTERNATIONAL SEARCH REPORT

Information on patent family members

International application No

PCT/IB2019/001054

Patent document cited in search report	Publication date	Patent family member(s)	Publication date
WO 9929252	A1	17-06-1999	
		AU 1719999 A	28-06-1999
		JP 4118510 B2	16-07-2008
		JP 2001525215 A	11-12-2001
		US 5961528 A	05-10-1999
		US 6379362 B1	30-04-2002
		WO 9929252 A1	17-06-1999

US 7730563	B1	08-06-2010	NONE

US 2002042618	A1	11-04-2002	NONE

EP 2014251	A1	14-01-2009	
		EP 2014251 A1	14-01-2009
		US 2009014011 A1	15-01-2009
