



US010143269B2

(12) **United States Patent**  
**Leo**

(10) **Patent No.:** **US 10,143,269 B2**  
(45) **Date of Patent:** **Dec. 4, 2018**

(54) **SHOE CHARM HOLDER DEVICE**

(71) Applicant: **Susan Leo**, Newfane, NY (US)

(72) Inventor: **Susan Leo**, Newfane, NY (US)

(\* ) Notice: Subject to any disclaimer, the term of this patent is extended or adjusted under 35 U.S.C. 154(b) by 968 days.

(21) Appl. No.: **14/244,412**

(22) Filed: **Apr. 3, 2014**

(65) **Prior Publication Data**

US 2014/0215859 A1 Aug. 7, 2014

**Related U.S. Application Data**

(63) Continuation-in-part of application No. 13/734,003, filed on Jan. 4, 2013, which is a continuation-in-part of application No. 13/421,927, filed on Mar. 16, 2012, which is a continuation-in-part of application No. 12/859,916, filed on Aug. 20, 2010, now Pat. No. 8,544,196.

(51) **Int. Cl.**  
*A43B 23/00* (2006.01)  
*A43B 23/24* (2006.01)  
*A44C 17/02* (2006.01)  
*A44C 25/00* (2006.01)

(52) **U.S. Cl.**  
CPC ..... *A43B 23/24* (2013.01); *A44C 17/02* (2013.01); *A44C 25/007* (2013.01); *Y10T 24/13* (2015.01)

(58) **Field of Classification Search**  
CPC ..... Y10T 24/13; A43B 23/24; A44C 17/02; A44C 25/007; B42F 3/00  
USPC ..... 36/136, 137; 2/245, 243.1; 24/103, 24/114.5

See application file for complete search history.

(56) **References Cited**

U.S. PATENT DOCUMENTS

818,983 A *	4/1906	Smith .....	A44B 1/08 24/114.1
979,361 A	12/1910	Vulpescu	
1,414,748 A	5/1922	Palmer	
1,484,785 A	2/1924	Hiss	
1,919,095 A	7/1933	De Gennaro	
1,977,995 A *	10/1934	Morali .....	A43B 3/0078 12/142 R
2,096,335 A	10/1937	Nicholas	
2,139,885 A	12/1938	De Gironimo	
2,174,521 A	10/1939	Lancaster	
2,470,200 A	5/1949	Wallach	

(Continued)

FOREIGN PATENT DOCUMENTS

WO WO2013007895 \* 1/2013 ..... A43B 1/0081

OTHER PUBLICATIONS

United States Patent and Trademark Office, Non-Final Office Action dated, Nov. 25, 2013 for U.S. Appl. No. 13/421,927.

(Continued)

*Primary Examiner* — Timothy K Trieu  
(74) *Attorney, Agent, or Firm* — Hansen IP Law PLLC

(57) **ABSTRACT**

A charm holder device for attaching charms to a shoe is shown and described. The charm holder device allows a charm to be selectively attached to and detached from the shoe. A charm keeper is attached to the decorative body for attaching charms. In some of the described examples, the charm holder device is placed between the heel of the shoe and a ground-contacting portion of the shoe's sole such that the charm holder and the charm are spaced apart from the ground-contacting portion of the sole in a direction perpendicular to the ground-contacting portion of the sole.

**22 Claims, 14 Drawing Sheets**

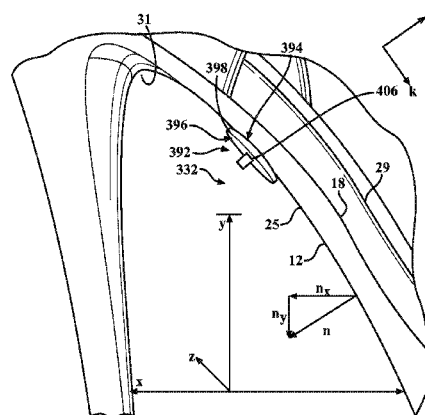
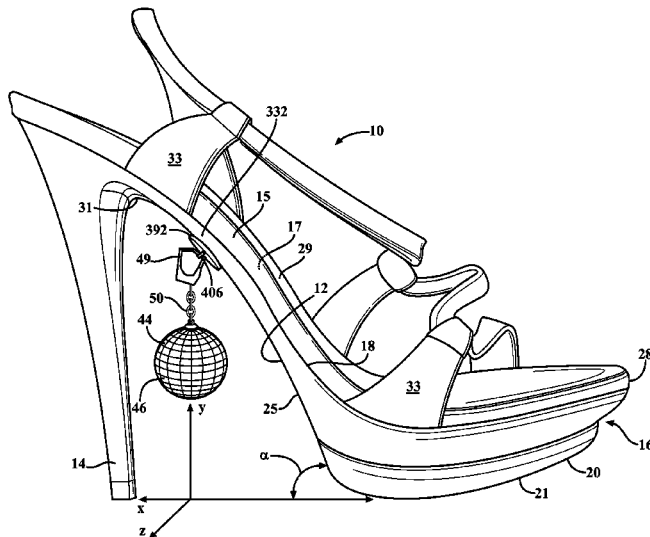

(56)

References Cited

U.S. PATENT DOCUMENTS

2,552,151	A	5/1951	Cohen	6,698,986	B2	3/2004	Fraleigh	
2,689,417	A	9/1954	Bernstein et al.	7,004,699	B2	2/2006	Petrok et al.	
2,723,344	A	11/1955	Greminger	7,059,070	B2	6/2006	Omstead et al.	
2,748,517	A	6/1956	Berkis	7,076,894	B2	7/2006	Santos et al.	
3,141,211	A	7/1964	Blake	7,578,075	B1	8/2009	Kemp	
3,354,561	A	11/1967	Cameron	7,661,208	B2	2/2010	McKinney et al.	
3,357,063	A	12/1967	Eiben	7,695,154	B2	4/2010	Ellenburg et al.	
3,722,565	A	3/1973	Miller et al.	7,713,013	B2	5/2010	Sedgwick et al.	
3,787,935	A *	1/1974	Kapitan	7,819,721	B1 *	10/2010	Messier	A41D 27/08 2/244
3,893,247	A	7/1975	Dana, III	7,877,902	B2	2/2011	Pieriboni	
3,946,505	A	3/1976	Dana, III	7,937,966	B2	5/2011	Golove et al.	
4,033,243	A	7/1977	Kirrish et al.	7,987,619	B2	8/2011	McKinney et al.	
4,050,167	A	9/1977	Senter	7,988,397	B2	8/2011	Bodin et al.	
4,128,861	A	12/1978	Pelengaris	8,001,664	B2	8/2011	Pearce	
4,164,971	A	8/1979	Strand	8,069,583	B1	12/2011	Simchuk	
4,202,117	A	5/1980	Bidegain	8,176,658	B2 *	5/2012	Katz	A43B 1/0027 36/100
4,490,083	A	12/1984	Rebish					
4,724,628	A	2/1988	Schreiner	8,210,785	B1	7/2012	Gager	
4,805,320	A	2/1989	Goldenberg et al.	9,468,253	B2 *	10/2016	Floriot Godin	A43B 1/0081
4,887,369	A	12/1989	Bailey et al.	2006/0026990	A1	2/2006	Carter	
5,079,857	A	1/1992	Clifton	2006/0075662	A1	4/2006	Schupbach	
5,243,776	A	9/1993	Zelinko	2006/0180728	A1	8/2006	Abrantes	
5,244,326	A	9/1993	Henriksen	2008/0289076	A1	11/2008	Millward	
5,290,131	A	3/1994	Henriksen	2009/0049719	A1 *	2/2009	Compton	G09F 21/02 40/586
5,371,662	A	12/1994	Shenk-Ko					
5,461,814	A	10/1995	Reid et al.	2009/0100869	A1	4/2009	Golove et al.	
5,490,338	A	2/1996	Hwang et al.	2009/0249654	A1	10/2009	Baucom et al.	
5,549,234	A	8/1996	Hong	2010/0185259	A1 *	7/2010	Shiba	A61H 39/002 607/48
5,655,317	A	8/1997	Grant					
5,673,501	A	10/1997	Mathews	2010/0239386	A1	9/2010	Sedgwick et al.	
5,926,980	A	7/1999	Adam	2010/0289971	A1	11/2010	Odland et al.	
6,012,763	A	1/2000	Clemente et al.	2010/0307031	A1	12/2010	Ganito	
6,115,946	A	9/2000	Morris et al.	2011/0083341	A1	4/2011	Baum	
6,266,853	B1	7/2001	Ho	2012/0137474	A1 *	6/2012	Erikson	A44B 1/04 24/3.1
6,345,472	B1	2/2002	Taylor	2012/0137543	A1	6/2012	Kemp	
6,354,231	B1	3/2002	Morris	2012/0186105	A1	7/2012	Kemp et al.	
6,389,712	B1	5/2002	Schelling	2012/0297647	A1 *	11/2012	Whigham	A43B 3/126 36/136
6,434,870	B1	8/2002	Fanjoy					
6,442,872	B1	9/2002	Liao					
6,481,122	B2	11/2002	Brahler					
6,502,332	B1	1/2003	Nakayama					
6,632,168	B2 *	10/2003	Roberts					
6,675,611	B2	1/2004	Hunter					

OTHER PUBLICATIONS

United States Patent and Trademark Office, Final Office Action dated, May 7, 2014 for U.S. Appl. No. 13/421,927.

\* cited by examiner



FIG. 2

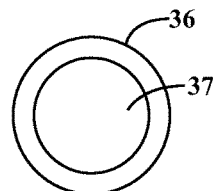
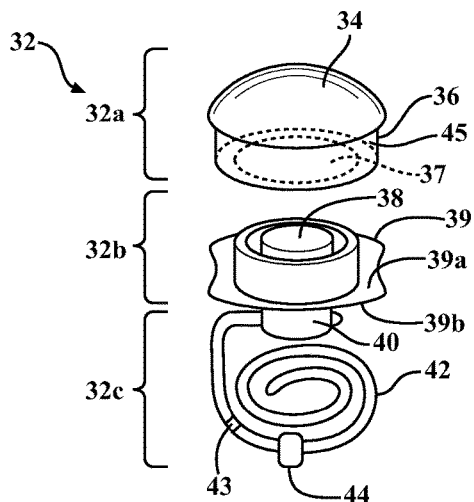

FIG. 3

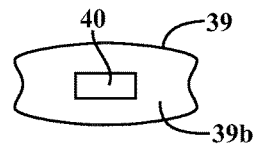

FIG. 4

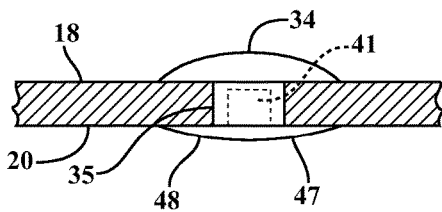

FIG. 5

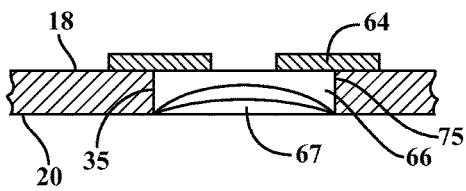

FIG. 7

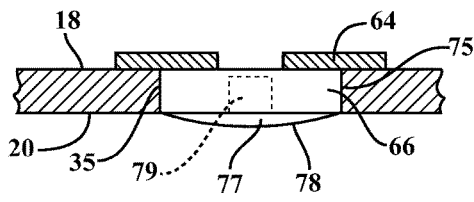

FIG. 8

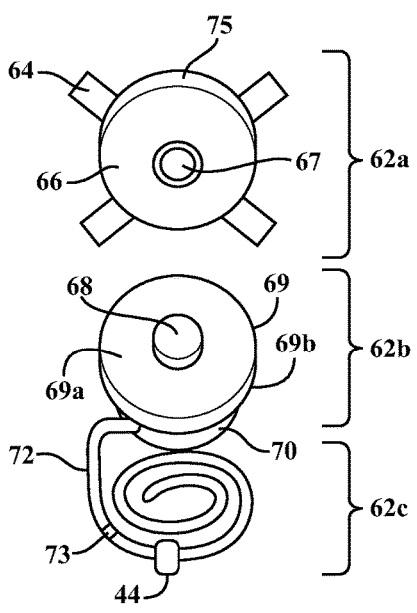
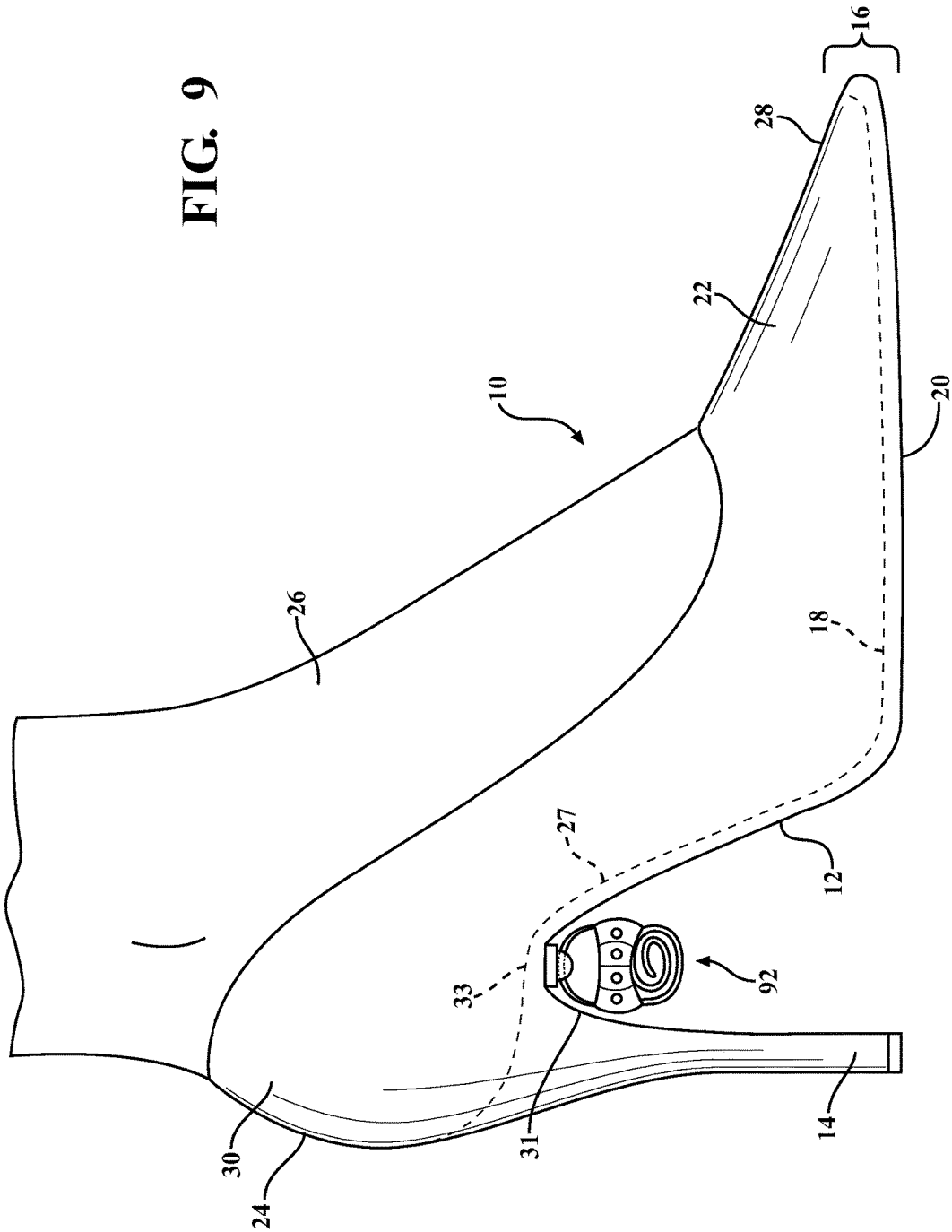

FIG. 6

FIG. 9



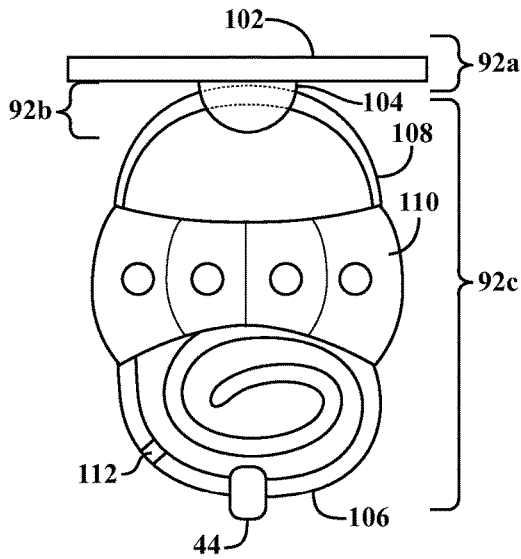

FIG. 10

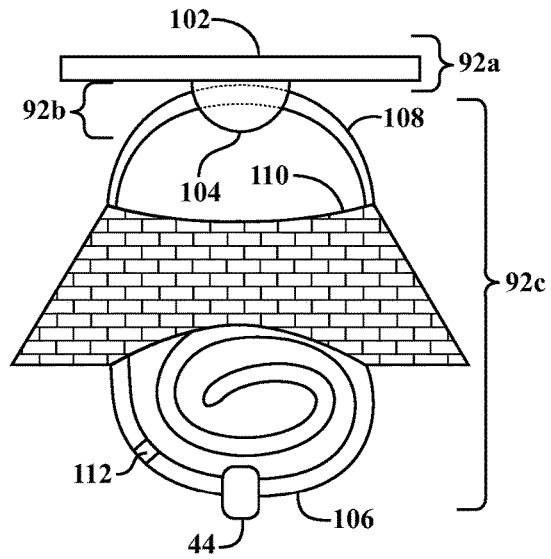

FIG. 11

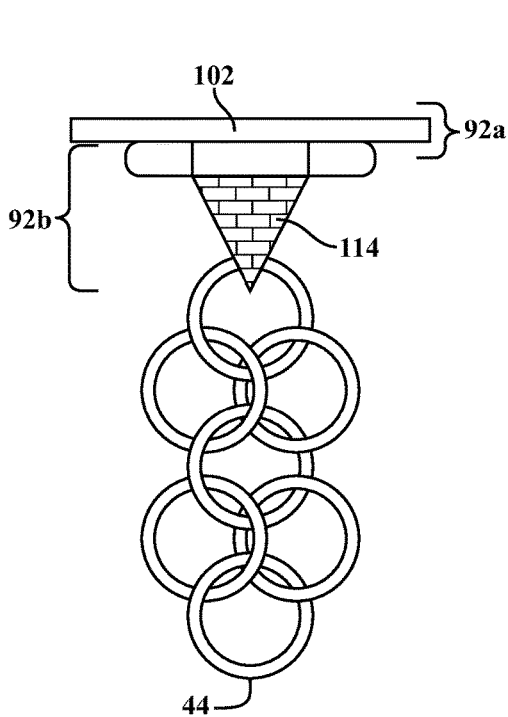

FIG. 12

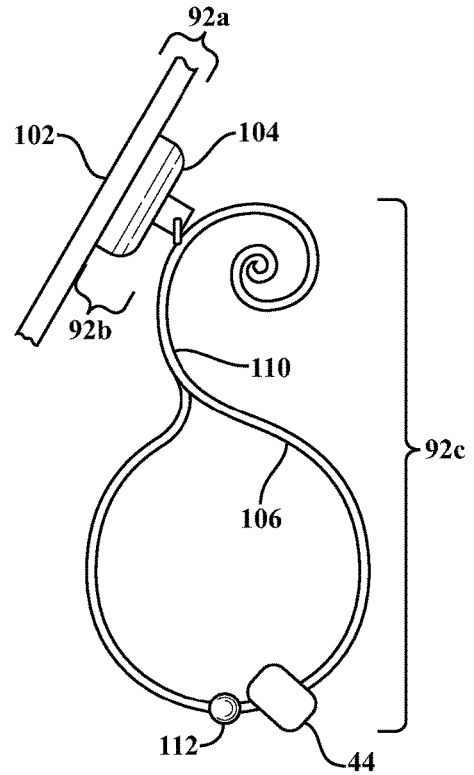

FIG. 13

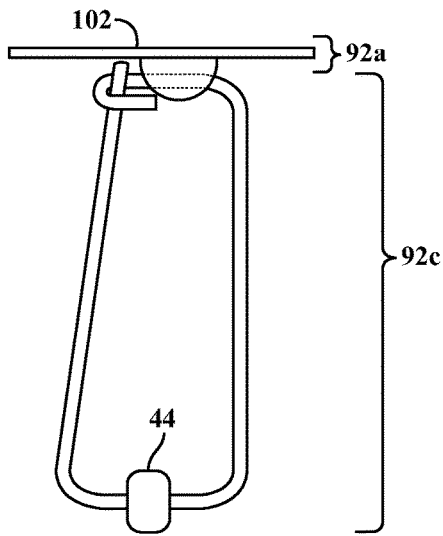

FIG. 14A

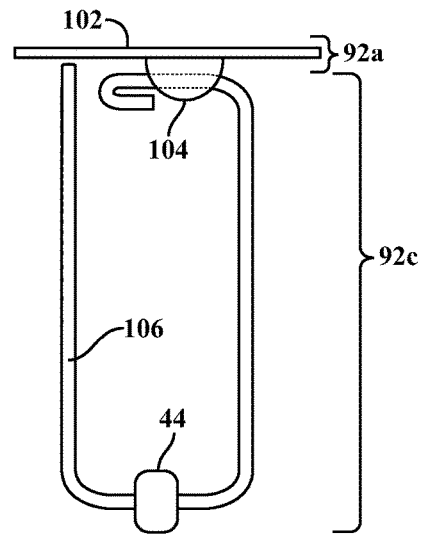

FIG. 14B

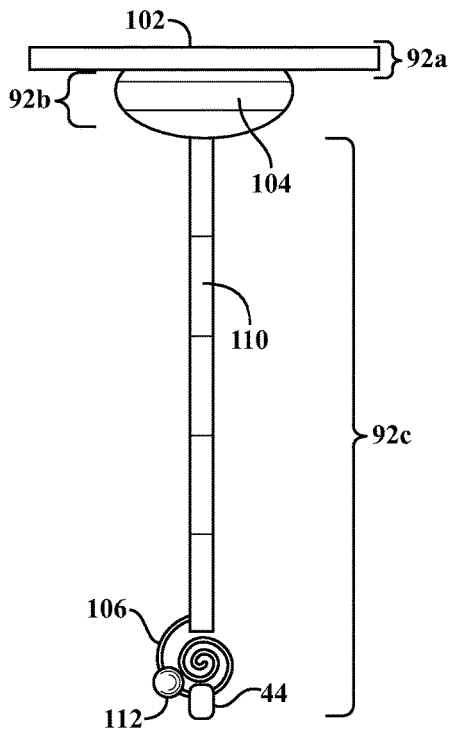

FIG. 15

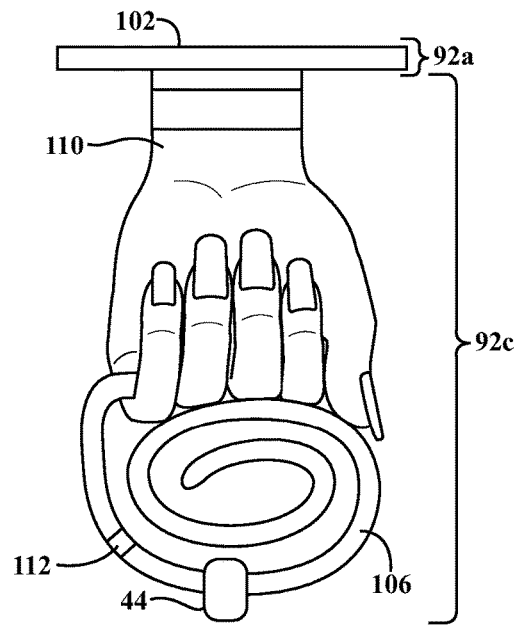

FIG. 16

FIG. 17

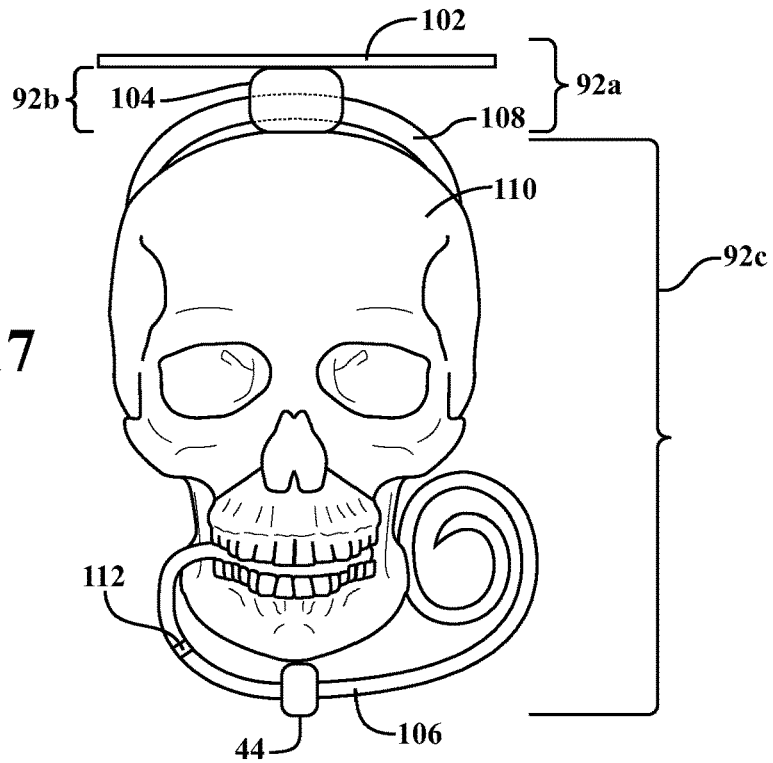
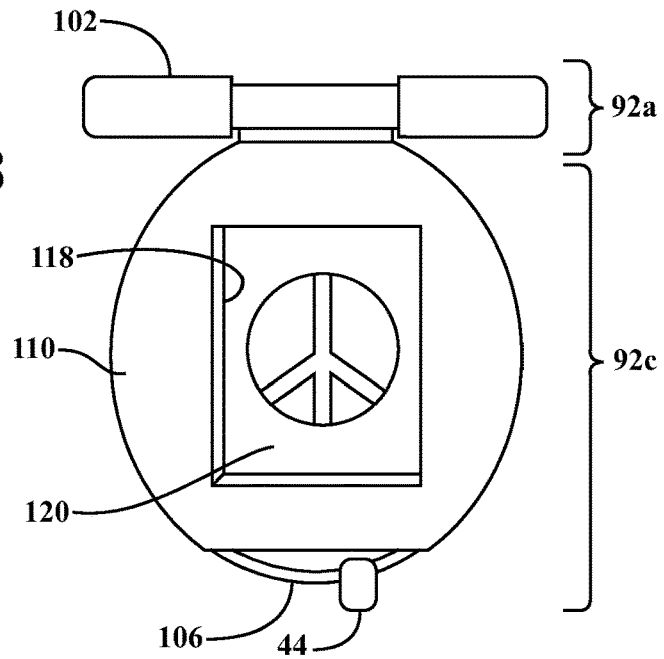

FIG. 18



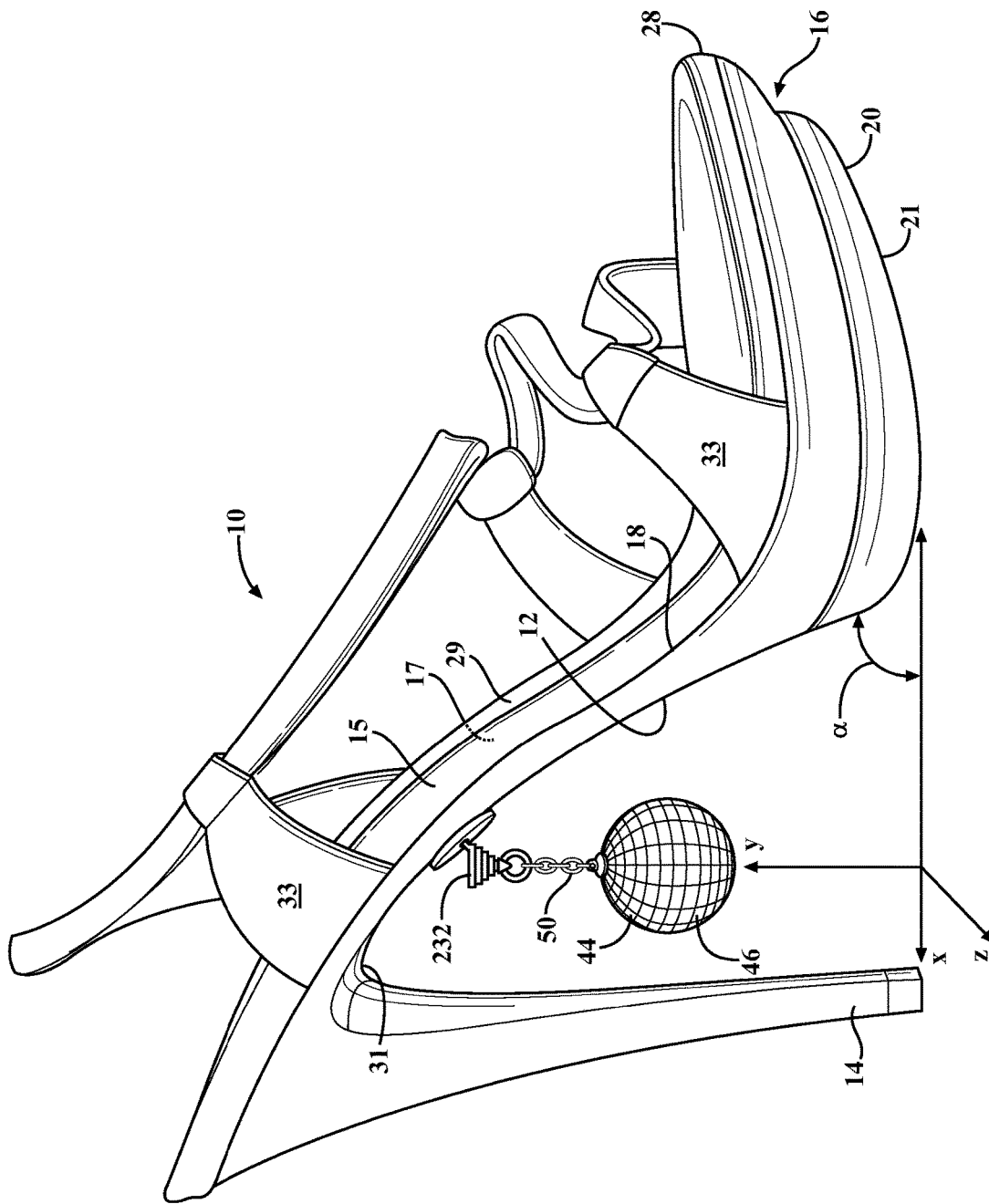

FIG. 19



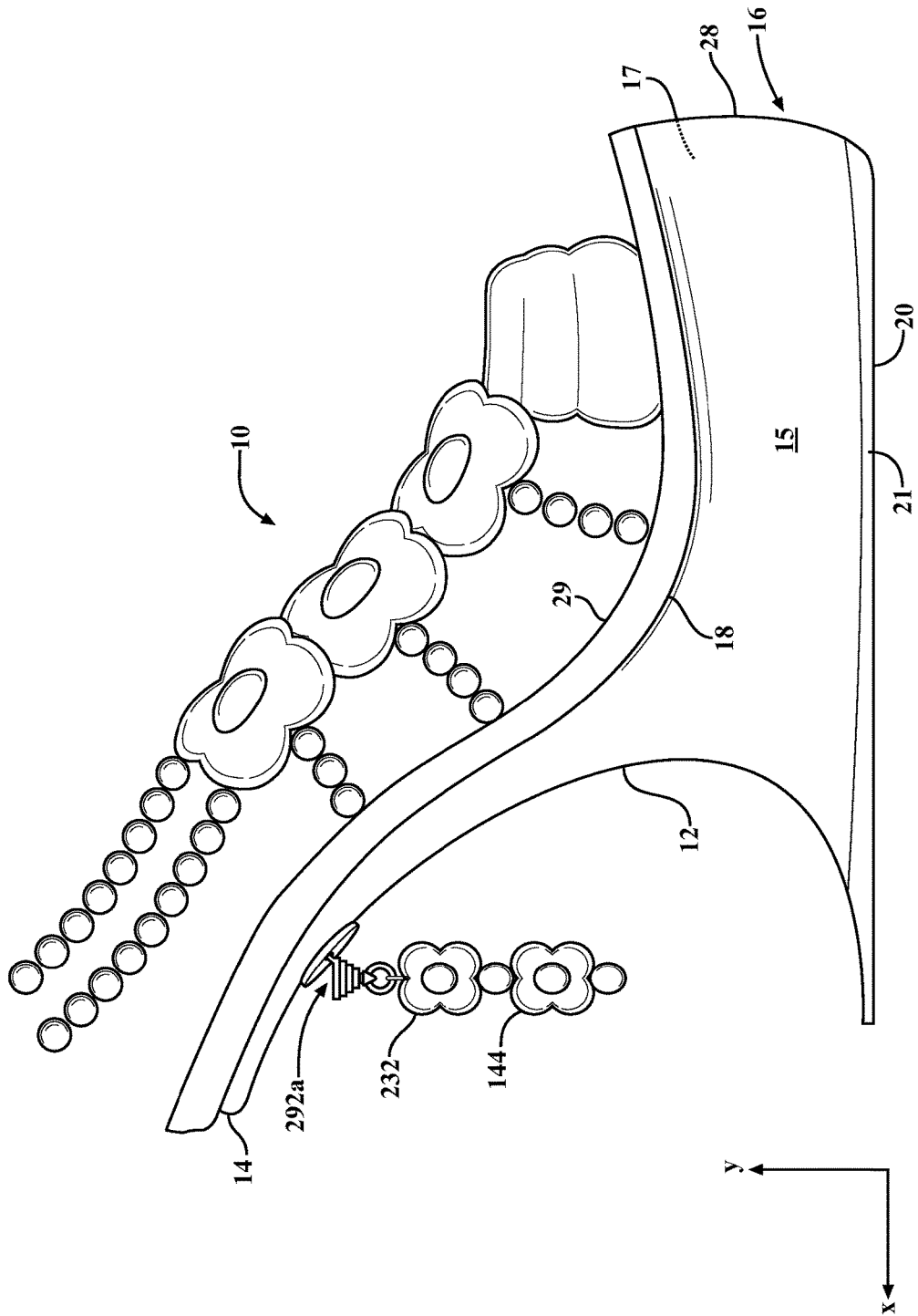

FIG. 21

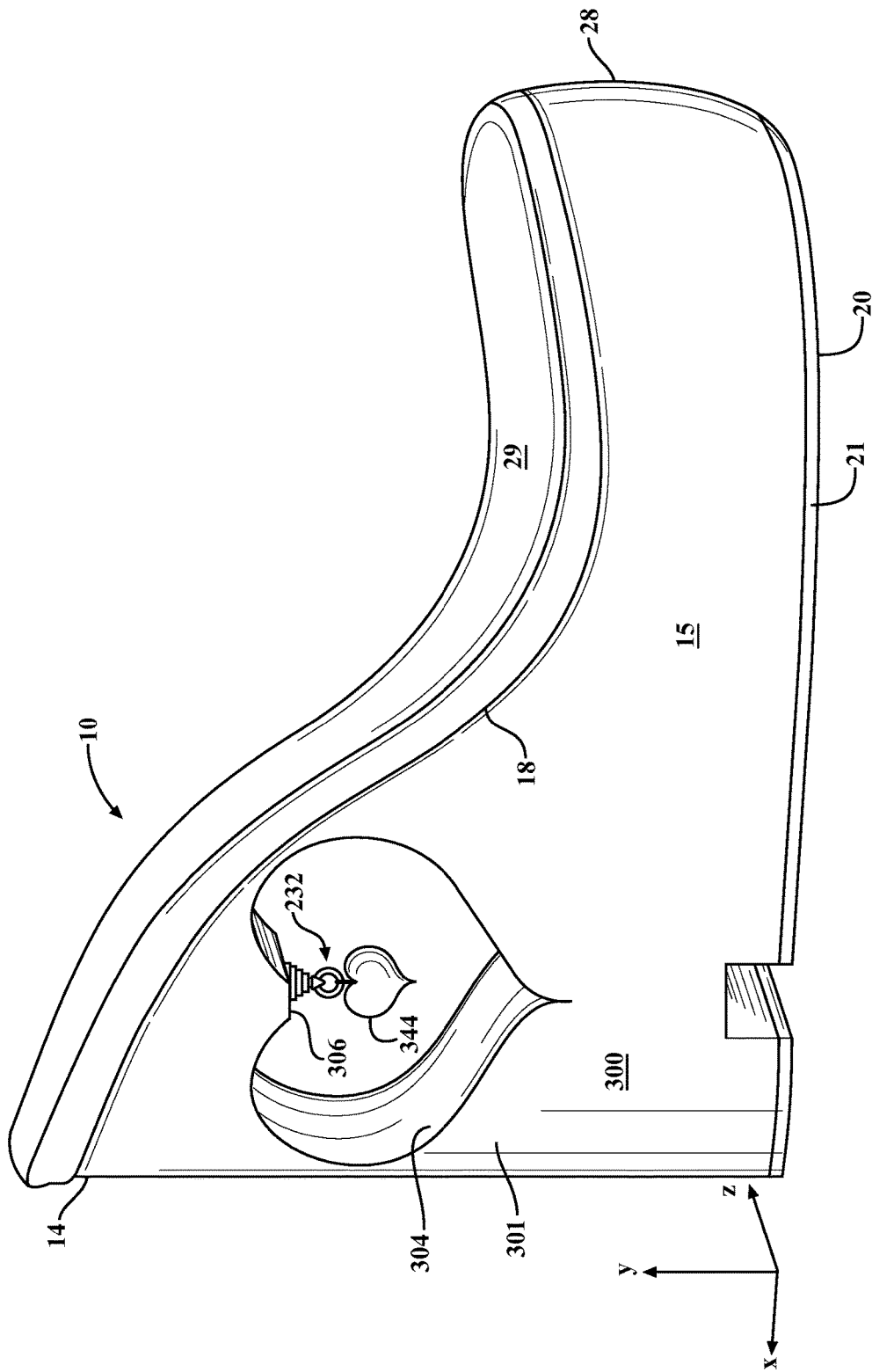



FIG. 23B

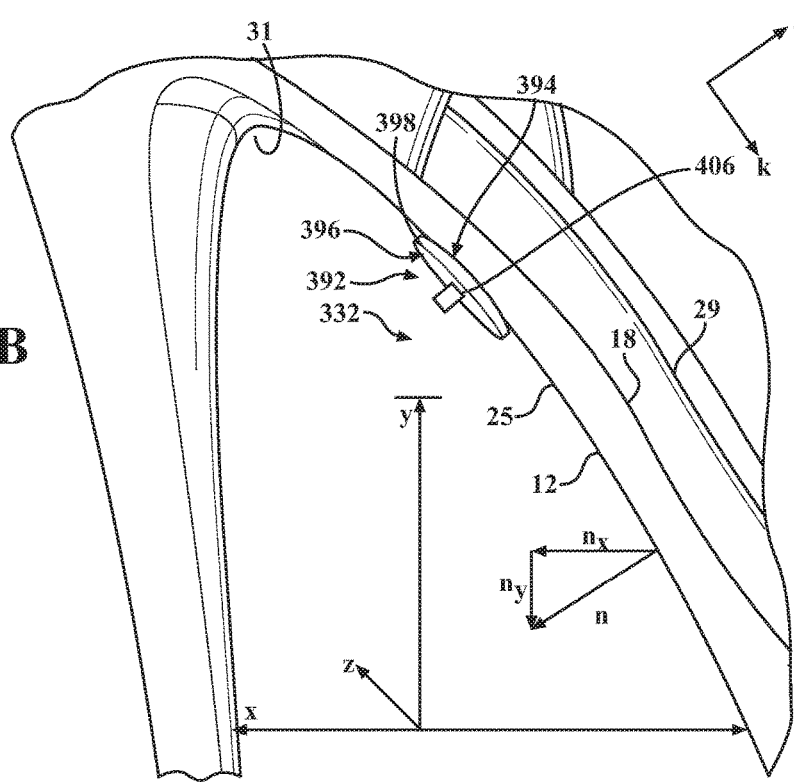
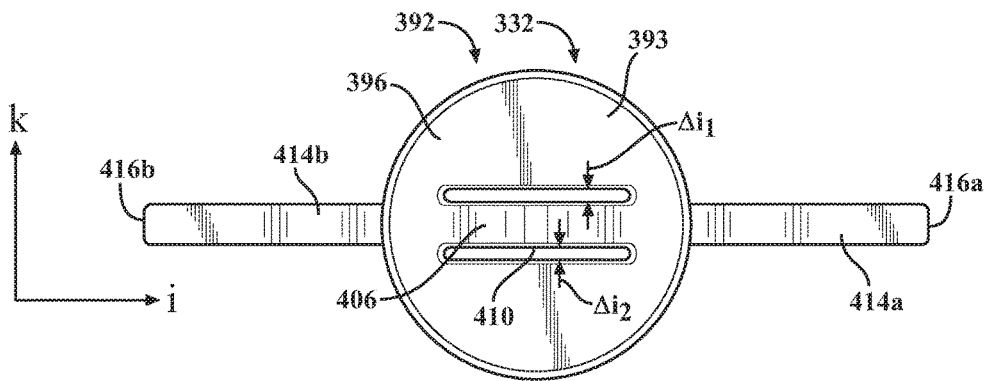

FIG. 24



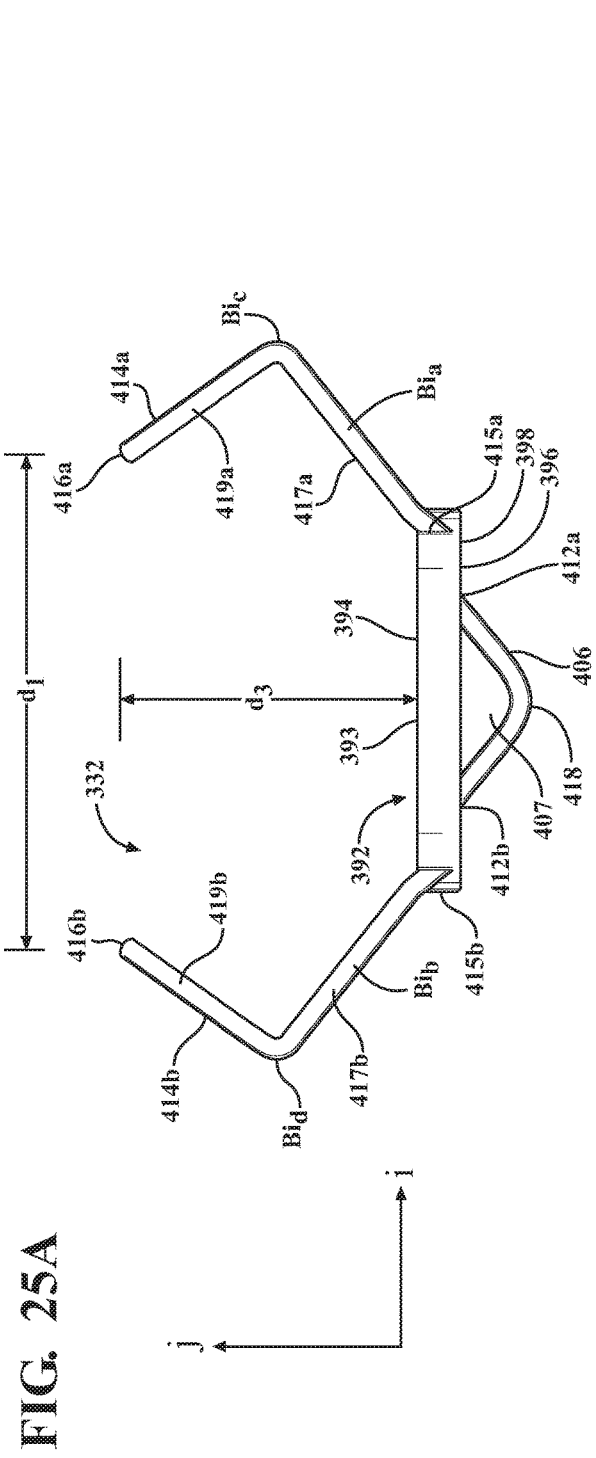

FIG. 25A

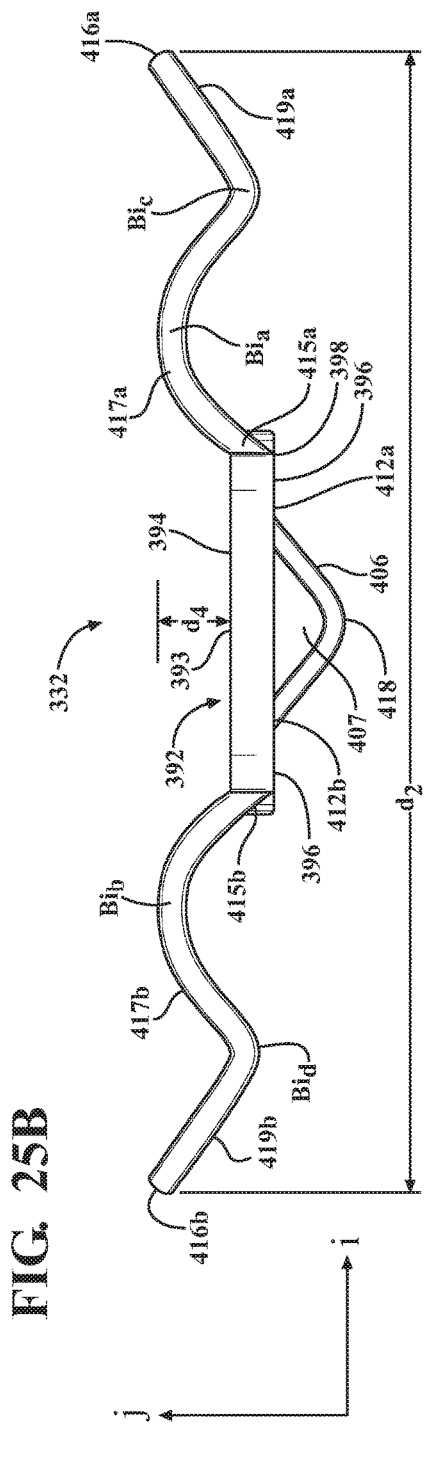

FIG. 25B

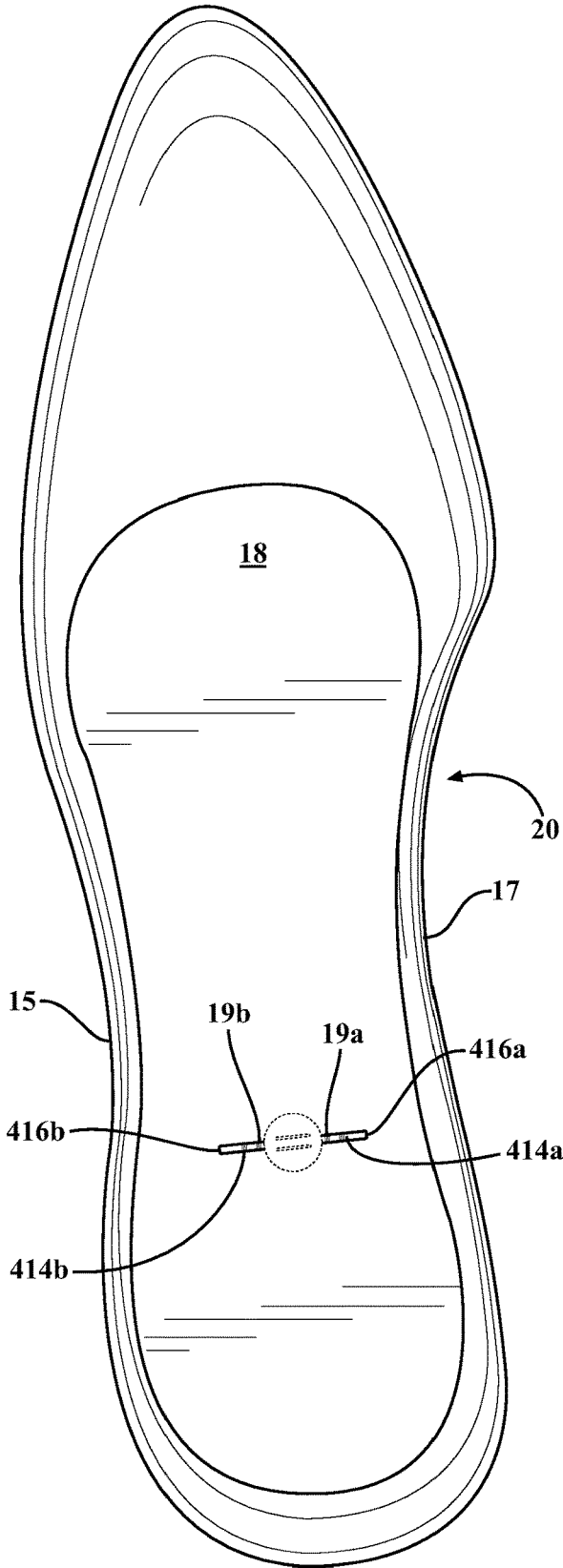

FIG. 26

**SHOE CHARM HOLDER DEVICE****CROSS-REFERENCE TO RELATED APPLICATIONS**

This is a continuation-in-part of U.S. patent application Ser. No. 13/734,003, filed Jan. 4, 2013, which is a continuation-in-part of U.S. patent application Ser. No. 13/421,927, filed Mar. 16, 2012, which is a continuation-in-part of U.S. patent application Ser. No. 12/859,916, filed Aug. 20, 2010, now U.S. Pat. No. 8,544,196, each of which are hereby incorporated herein by reference.

**FIELD**

This disclosure relates to charm holder devices for attachment to shoes.

**BACKGROUND**

Certain known shoe designs include a variety of fixed and selectively detachable decorative features. However, known designs do not include the ability to attach dangling charms to the sole of a shoe or other shoe surfaces with a downward facing component. Thus, a need has arisen for a charm holder device.

**BRIEF DESCRIPTION OF THE DRAWINGS**

FIG. 1 shows a schematic of a shoe with a shoe charm holder device in a first embodiment;

FIG. 2 shows a schematic of a shoe charm holder device of a first embodiment;

FIG. 3 shows a schematic of a bottom view of the shoe engaging portion of the shoe charm holder device of a first embodiment received by an insole of a shoe;

FIG. 4 shows a schematic of a bottom view of the charm engaging portion of the shoe charm holder device of a first embodiment received by the shoe engaging portion of the shoe charm holder;

FIG. 5 shows a cap received by the attachment portion of the shoe charm holder device of a first embodiment when a wearer does not want to attach the charm engaging portion of the shoe charm holder device;

FIG. 6 shows a schematic of the attachment portion, shoe engaging portion, and the charm engaging portion of the shoe charm holder device of a second embodiment;

FIG. 7 shows a schematic of a cap of the shoe charm holder device received by an insole of a shoe of a second embodiment;

FIG. 8 shows a cap received by the attachment portion of the shoe charm holder device of a second embodiment when a wearer does not want to attach the charm engaging portion of the shoe charm holder device;

FIG. 9 shows a schematic of a shoe with a shoe charm holder device attached to an outer sole of the shoe of a third embodiment;

FIG. 10 shows an example of a shoe charm holder device design for attachment to the heel breast of a shoe;

FIG. 11 shows another example of a shoe charm holder device design for attachment to the heel breast of a shoe;

FIG. 12 shows another example of a shoe charm holder device design for attachment to the heel breast of a shoe;

FIG. 13 shows another example of a shoe charm holder device design for attachment to the heel breast of a shoe;

FIG. 14A shows another example of a shoe charm holder device design for attachment to the heel breast of a shoe in a first configuration;

FIG. 14B shows the shoe charm holder device of FIG. 14A in a second configuration;

FIG. 15 shows another example of a shoe charm holder device design for attachment to the heel breast of a shoe;

FIG. 16 shows another example of a shoe charm holder device design for attachment to the heel breast of a shoe;

FIG. 17 shows another example of a shoe charm holder device design for attachment to the heel breast of a shoe;

FIG. 18 shows another example of a shoe charm holder device design for attachment to the heel breast of a shoe;

FIG. 19 is a side elevational view of a shoe comprising a charm holder device and a selectively detachable charm;

FIG. 20 is a close-up view of the charm holder device of FIG. 19;

FIG. 21 is a side elevational view of a shoe comprising a charm holder device and a selectively detachable charm in which the heel does not contact the ground;

FIG. 22 is a side elevational view of a wedge shoe (with the vamp omitted) comprising a charm holder attached within a cut-out portion of the shoe;

FIG. 23a is a side elevational view of a shoe with another exemplary charm holder device attached to the outsole of the shoe and a selectively detachable charm attached to the charm holder device;

FIG. 23b is a close-up side elevational view of the shoe of FIG. 23a with the charm removed from the charm holder device;

FIG. 24 is a bottom plan view of the charm holder device of FIG. 23a;

FIG. 25a is a side elevational view of the charm holder device of FIG. 23a with the first and second stakes in a first configuration;

FIG. 25b is a side elevational view of the charm holder device of FIG. 23a with the first and second stakes in a second configuration; and

FIG. 26 is a top plan view of the sole of the shoe of FIG. 23a.

**DETAILED DESCRIPTION**

As shown in FIGS. 1 and 9, a shoe 10 includes a shank 12 connected to a heel 14, through a heel breast 31 and a sole assembly 16. The shoe 10 also includes an upper covering of the toe region 22 and a counter 24 to support a heel of a wearer's foot 26. The sole assembly 16 includes an insole or inner sole 18 in the interior bottom of the shoe directly beneath the wearer's foot and an outer sole or outsole 20 in contact with the ground. The insole 18 is configured with the foot shape profile of the shoe with a toe end 28, connected to an arch profile 27 corresponding to the natural curvature of the foot's arch through to a heel end 30. The outsole 20 may be made of any suitable outsole material including, but not limited to leather, PVC, polyurethane, TPR, rubber or any combination thereof.

In the first embodiment shown in FIGS. 1 through 5, a bore 35 is present on the heel breast 31 between the shank 12 and the heel 14 of the shoe. The bore 35 extends from the insole 18 through to the outsole 20. The bore 35 receives a portion of a charm holder device 32.

Referring to FIG. 2, the shoe charm holder device 32 has an attachment portion 32a which attaches the shoe charm holder device 32 to the shoe 10; a shoe engaging portion 32b which is coupled to the attachment portion 32a and couples

the charm engaging portion 32c to the shoe 10; and a charm engaging portion 32c for receiving charms or beads 44.

In the first embodiment, the attachment portion 32a of the shoe charm holder device 32 includes a cap head 34 connected to a female socket 36 with outer walls 45 received by a bore 35 on the heel breast 31 of the shoe. The female socket 36 defines an opening 37 for receiving a protruding male snap stud 38 as shown in FIG. 2.

The cap head 34 is preferably mounted perpendicular to outer sides 45 of the female socket 36. The outer sides 45 of the female socket 36 are received within the bore 35. The cap head 34 preferably has a diameter that is larger than the diameter of the bore 35, preventing the cap head 34 from moving from the insole 18 to the outsole 20 through the bore 35. The cap head 34 is preferably shaped such that the cap head 34 is unobtrusive to the wearer's foot. The cap head 34 may be a pan head, a button or dome head, a round head, or a truss head, or any other type of head that is unobtrusive to the wearer's foot. In certain preferred examples, the cap head 34 is covered by a portion of a shoe upper that forms a layer covering the insole 18 and the cap head 34.

The shoe engaging portion 32b includes a base 39 with a first side 39a including a protruding male snap stud 38 and a second side 39b with a nipple 40 for coupling to a charm keeper 42 of the charm engaging portion 32c as shown in FIG. 4. The shoe engaging portion 32b attaches to the attachment portion by snapping the protruding male snap stud 38 into the female socket 36.

The charm keeper 42 may be fixedly attached to the nipple 40 or removably attached to the nipple 40 through a clasp (not shown). In the example of FIG. 2, the charm keeper 42 is fixedly attached to nipple 40. The charm keeper 42 has a hinge 43 which allows the charm keeper 42 to be moved from a first position in which charms or beads 44 may be added or removed from the charm keeper 42 to a second position in which charms or beads 44 are prevented from being removed or dislodged from the charm keeper 42.

Referring to FIG. 5 when a wearer does not wish to have the charm engaging portion 32c present on the heel breast 31 of the shoe, the shoe engaging portion 32b and charm engaging portion 32c are removed from the attachment portion 32a, and a separate male cap stud 48 with a head 47 is received by the female socket 36 of the attachment portion 32a, such that when the protruding male snap stud 41 of the separate male cap stud 48 snaps into the female socket 36, with the head 47 resting against the outer sole 20 of the shoe 10, the shoe charm holder device 32 appears flat or nearly flush with the outer sole 20 of the underside of the shoe 10. Note that in FIG. 5, the cap head 34 is depicted projecting away from the insole 18 for ease of illustration. However, in preferred examples, the cap head 34 is substantially flat and does not project away the insole 18 by an appreciable distance.

FIGS. 6-8 show an alternate charm holder device of a second embodiment received within a bore 35 on the heel breast 31 of the shoe 10 between the shank 12 and heel 14 of the shoe 10 that extends from the insole 18 through to the outsole 20.

In this embodiment, the shoe charm holder device 62 has an attachment portion 62a which attaches the shoe charm holder device 62 to the shoe 10; a shoe engaging portion 62b which is coupled to the attachment portion 62a and couples the charm engaging portion 62c to the shoe 10; and a charm engaging portion 62c for receiving charms or beads 44.

The attachment portion 62a of the shoe charm holder device 62 includes laterally extending tabs 64 that extend outwards from outer walls 75 of a female magnetic socket 66

received by the bore 35 and rest on or engage the insole 18 of the shoe 10. The tabs 64 prevent the female magnetic socket 66 from moving from the insole 18 to the outsole 20 through the bore 35. The tabs 64 lay flat on the insole 18 and are not obtrusive to the wearer's foot. The female socket 66 defines an opening 67 for receiving a protruding male snap stud 68 as shown in FIG. 6.

The shoe engaging portion 62b includes a base 69 with a first side 69a including a protruding male magnetic snap stud 68 and a second side 69b with a nipple 70 for coupling to a charm keeper 72 of the charm engaging portion 62c. The shoe engaging portion 62b attaches to the attachment portion 62a by magnetically snapping the protruding male snap stud 68 into the female socket 66.

The charm keeper 72 may be fixedly attached to the nipple 70 or removably attached to the nipple 70 through a clasp (not shown). The charm keeper 72 has a hinge 73 which allows the charm keeper 72 to be moved from a first position in which charms or beads 74 may be added or removed from the charm keeper 72 to a second position in which charms or beads 44 are prevented from being removed or dislodged from the charm keeper 72.

Referring to FIG. 8, when a wearer does not wish to have the charm engaging portion 62c present on the heel breast 31 of the shoe, a separate male cap stud 78 with a head 77 and a protruding male snap stud 79 is received by the female socket 66 of the attachment portion 62a, such that when the separate male cap stud 78 snaps into the female socket 66, with the head 77 resting against the outer sole 20 of the shoe 10, the shoe charm holder device 62 appears flat or nearly flush with the outer sole 20 of the underside of the shoe 10.

FIGS. 9-10 shows a charm holder device 92 of a third embodiment. The shoe charm holder device 92 has an attachment portion 92a which attaches the shoe charm holder device 92 to the shoe 10; a shoe engaging portion 92b which is coupled to the attachment portion 92a and couples the charm engaging portion 92c to the shoe 10; and a charm engaging portion 92c for receiving charms or beads 44.

The attachment portion 92a is an attachment surface 102 that is directly attached to the outer sole 20 of the shoe. The attachment surface 102 may be fixedly attached to the outer sole 20 of the shoe 10 using an adhesive. Alternatively, the attachment surface 102 may be removably attached using a hook and loop fastener material, such as 3M® Dual Loop® Fastener or through magnets, where another magnet is placed underneath the insole 18 of the shoe 10 and the attachment surface 102 on the outer sole 20 of the shoe is magnetically attracted to the magnet underneath the insole 18 of the shoe. It should be noted that the adhesive, hook and loop fastener or the magnets need to be of sufficient strength to manage the weight of the shoe engaging portion 92b and the charm engaging portion 92c including any charms 44 and maintain the attachment of the shoe engaging portion 92b and the charm engaging portion 92c to the shoe 10.

The shoe engaging portion 92b includes a nipple 104 for receiving a looped portion 108 for coupling to a charm keeper 106 of the charm engaging portion 92c for example as shown in FIGS. 14A-14B.

The looped portion 108 may be coupled to the charm keeper 106 through a body 110 as shown in FIGS. 10 and 11. The body 110 may be of various shapes such as irregular polygons and skulls. The looped portion 108 may include a clasp that allows the looped portion to be removed from the nipple 104. The shoe engaging portion 92b is preferably fixedly attached to the attachment portion 92a through an adhesive or may be removably attached by magnets.

Alternatively, shoe engaging portion **92b** includes a nipple **104** which is directly attached to the body **110** of the charm engaging portion, for example as shown in FIGS. **13** and **15**. In the example of FIG. **15**, body **110** preferably has a telescoping structure that provides an adjustable length so that the wearer can alter the spacing between the shoe engaging portion **92b** and the charm keeper **106** as desired.

In another embodiment, the shoe engaging portion **92b** can include a triangular protrusion **114** which can be directly coupled to a charm **44**, for example interconnected rings as shown in FIG. **12**.

In the charm holder devices of FIGS. **10-12**, all or part of the body **110** is positioned between charm keeper **106** and shoe attachment portion **92a** along a direction away from shoe attachment portion **92a**. In FIGS. **10-12**, the direction away from shoe attachment portion is perpendicular to the attachment surface **102** of shoe attachment portion **92a**. The charm holder devices of FIGS. **17** and **18** are oriented similarly.

In another embodiment, the body **110** of the charm engaging portion **92c** can be directly connected to the attachment portion **92a**, eliminating the shoe engaging portion **92b**. The body may be hand shaped or oval shaped, for example, as shown in FIGS. **16** and **18**, respectively.

The charm keeper **106** may include a hinge **112** which allows the charm keeper **106** to be moved from a first position in which charms or beads **44** may be added or removed from the charm keeper **106** to a second position in which charms or beads **44** are prevented from being removed or dislodged from the charm keeper **106**.

Additionally, the body of the shoe charm holder device in any of the embodiments may have a cutout **118** for receiving decorative plates **120** as shown in FIG. **18**.

The charms may be made of plastic, gold, silver, bronze, glass, nickel, or any other alloy.

It should be noted that the charms maybe of different lengths depending on the heel height of the shoe.

Furthermore, the charm or ornament **44** may be of any design that can be removably attached to the charm keeper and is not limited to any of the designs shown in the drawings.

While the shoes in FIGS. **1** and **9** are shown with an upper covering **22** of the toe region of a wearer's foot and a counter **24** to support the heel of a wearer, the shoe may alternatively just have straps on the toe region and/or around the heel.

In certain examples, the shoe **10** in which the shoe charm holder device is installed preferably has a heel that is at least 0.5 inches above the ground or greater and preferably includes, but is not limited to, kitten heels, high heels, and stilettos. However, as will be discussed further below, the charm holder device may also be installed on wedge shoes that have no heel shank or other appreciable clearance between the outsole and the ground.

Referring to FIG. **19**, an alternate example of a shoe **10** comprising a charm holder device **232** is depicted. Like numerals refer to like parts depicted in the previous examples. Shoe **10** comprises heel **14** and toe end **28** which are spaced apart from one another along a first (length) direction of the shoe **10** which defines an x-axis. Shoe **10** also includes a lateral side **15** and a medial side **17**. Shoe **10** also comprises an insole **18**, an outsole **20** which includes a ground-contacting portion **21**, a shank **12**, and a heel breast **31**. Shank **12** and heel breast **31** are located between ground-contacting portion **21** and heel **14** in a direction along the x-axis. In FIGS. **19** and **20**, charm **44** includes a decorative object **46** in the shape of a sphere and a chain **50** that connects the decorative object **46** to the charm holder

device **232**. Shoe **10** further includes a sock insole lining **29** located on the insole **18**. The sock insole lining **29** is in contact with the user's foot when the shoe **10** is worn. An upper **33** is also provided. A portion of the upper **33** which is not visible in the figures is located between the sock insole lining **29** and the insole **18** to hold the upper in place.

The ground-contacting portion **21** of outsole **20** and the charm holder device **232** are spaced apart in a second direction defining a second axis y. Lateral side **15** and medial side **17** of shoe **10** are spaced apart in a third direction defining a third axis z. Charm **44** is selectively detachable from and attachable to shoe **10** via charm holder device **232**. In certain examples, and as shown in FIG. **19**, charm **44** is capable of swinging movement relative to the charm holder device **232**, heel **14**, shank **12**, and ground-contacting outsole portion **21**. In other examples, charm **44** is capable of swinging along the x-axis, along the z-axis, and/or along directions having components along both the x-axis and the z-axis. As shown in FIG. **19**, in certain preferred examples, charm **44** is spaced apart from the ground-contacting portion **21** of outsole **20** in the y-axis direction so that charm **44** does not drag along the ground during use. In certain examples, the bottom of the charm **44** extends no lower than half the distance between the outsole **20** and the ground at the heel **14**. In the same or other examples, charm **44** is spaced apart from shank **12** in a first direction along the x-axis and is spaced apart from heel **14** in a second direction along the x-axis so that it can swing freely along the x-axis. Similarly, in the example of FIG. **19**, charm holder device **232** is itself spaced apart from the ground-contacting portion **21** of outsole **20** in the y-axis direction and is located on the shank **12** of outsole **20**.

Referring to FIG. **20**, a close-up view of charm holder device **232** is provided. Charm holder device **232** comprises a shoe attachment portion **292a**, a body **210**, and a charm keeper **206**. Body **210** may take a variety of polygonal, regular, or irregular three-dimensional shapes, but in preferred examples is a decorative ornament. In the specific example of FIGS. **19** and **20**, body **210** is in the shape of a pyramid.

In the illustrated example body **210** is located between charm keeper **206** and shoe attachment portion **292a** along a direction that projects away from shoe attachment portion **292a**. The specific direction in FIG. **20** is the y-axis direction (i.e., the direction that is perpendicular to the ground-contacting portion **21** of outsole **20**). In certain examples, body **210** may be selectively attachable to and detachable from shoe attachment portion **292a**. However, in the particular example of FIGS. **19** and **20**, body **210** is fixedly attached to shoe attachment portion **292a**. Body **210** may be integrally formed with shoe attachment portion **292a** to provide such fixed attachment. Alternatively, shoe attachment portion **292a** and body **210** may be separately formed and then attached to one another.

In certain examples, charm holder device **232** is selectively attachable to and detachable from outsole **20** of shoe **10**. In other examples, charm holder device **232** is fixedly attached to outsole **20** of shoe **10**. In one selectively attachable and detachable example, shoe attachment portion **292a** comprises a magnetic material and a complementary magnetic material is embedded between the inner sole **18** and outer sole **20** along shank **12** so that when shoe attachment portion **292a** is placed in contact with outer sole **20**, it is held to the out sole **20** by magnetic attraction to the complementary magnetic material. In other selectively attachable and detachable examples, shoe attachment portion **292a** may be

configured with a hook or loop fastener that is selectively attachable to a complementary hook or loop fastener affixed to outer sole 20.

Shoe attachment portion 292a is preferably a thin circular, triangular, or square shaped structure having a shoe contacting surface 294 that abuttingly engages the outsole 20 at a location between the sole ground-contacting portion 21 and the heel 14 in a direction along the x-axis. In general, shoe attachment portion 292a may be located at the shank 12 or the heel breast 31, but is shown located at shank 12 in FIGS. 19 and 20. However, as will be discussed further below, in certain examples the shoe attachment portion 292a may engage a surface of a shoe other than one along the outsole.

In the example of FIGS. 19 and 20, first shoe-contacting surface 294 of shoe attachment portion 292a is substantially planar. Shoe attachment portion 292a also includes a second surface 296 opposite the first surface 294. In the example of FIGS. 19 and 20, second surface 296 is also substantially planar. Shoe attachment portion 292a also has a thickness that defines a perimeter surface 298. In certain examples, including the example of FIGS. 19 and 20, the shoe-contacting surface 294 has a surface area, the perimeter surface 298 has a surface area, and the surface area of shoe contacting surface 294 is greater than the surface area of perimeter surface 298. In certain examples, the surface area of second surface 296 of shoe attachment portion 292a is also greater than the surface area of the perimeter surface 298. In general, increasing the surface area of contact between the outsole 20 along shank 12 and the first surface 294 at a given charm holder device 232 weight better ensures that the charm holder device 232 remains affixed to outsole 20. The first and second surfaces 294 and 296 of shoe attachment portion 292a may have a variety of shapes (when viewing surfaces 294 and 296 along a direction perpendicular to surfaces 294 and 296), including circles, ovals, squares, rectangles, and triangles. In certain preferred examples, the shape is selected from the group consisting of circles, squares, and rectangles. In the embodiment of FIGS. 19 and 20, each of the first and second surfaces 294 and 296 is in the shape of a circle when viewed along a direction perpendicular to first and second surfaces 294 and 296.

Charm keeper 206 is a closed loop in FIGS. 19 and 20. Charms with clasps that can be selectively opened and closed may be attached to charm keeper 206. In other embodiments, charm keeper 206 may be selectively opened and closed to receive a corresponding portion of a charm. Charm keeper 206 includes a distal-most point 214 (FIG. 20) which is the point spaced farthest from body 210 and a proximal-most point which is connected to or spaced closest to body 210. In FIG. 20, charm keeper 206 has two proximal-most points 207a and 207b, each of which is connected to body 210.

The surface of charm keeper 206 at distal-most point 214 lies in a plane that is tangent to charm keeper 206. The tangent plane is parallel to the x-z plane and has a normal (i.e., an axis that intersects it at a ninety degree angle) that is parallel to the y-axis. Thus an angle  $\theta$  may be defined between the y-axis and a line  $l_1$  lying in a plane (not shown) parallel to the substantially planar surface 294 of shoe attachment portion 292a. In the example of FIGS. 19 and 20,  $\theta$  is an acute angle, which is preferable when shoe attachment portion 292a is attached to shank 12 because shank 12 defines an acute angle  $\alpha$  (FIG. 19) with respect to the ground and ground-contacting portion 21 of outsole 20. In other examples, and in particular those in which shoe attachment portion 292a is attached to heel breast 31, the angle  $\theta$  may

be substantially 90 degrees as would be the case with the charm holder devices of FIGS. 10-12.

In certain examples, and as shown in FIGS. 19 and 20, the distal-most point 214 of charm keeper 206 is spaced apart from the shoe attachment portion 292a by a distance  $h$  (FIG. 20) in a direction perpendicular (normal) to the tangent plane in which distal-most point 214 of charm keeper 206 lies. In the same or other examples, distal-most point 214 is spaced apart from the shoe attachment portion 292a by a distance  $w$  in a direction parallel to the tangent plane. In the example of FIGS. 19 and 20, the distal-most point 214 is spaced apart from the shoe attachment portion 292a by a distance  $h$  in the direction normal to the tangent plane in which distal-most point 214 lies and by a distance  $w$  in the direction parallel to the tangent plane. In addition, in the illustrated example,  $w$  is greater than  $h$ .

Second surface 296 of shoe attachment portion 292a may be characterized as having a central portion surrounded by a border portion. In certain examples, and as best seen in FIG. 20, body 210 is connected to second surface 296 at a central portion of second surface 296. In the case of FIGS. 19 and 20, body 210 is preferably connected to shoe attachment portion 292a at or substantially at the radial center of second surface 296. Body 210 is connected to shoe attachment portion 292a at a connection point 204. In certain examples, a shoe engaging portion such as the shoe engaging portions 92b of FIGS. 10-13 may also be provided to connect body 210 to shoe attachment portion 292a. The connection at connection point 204 may be made by soldering, welding, adhesive, mechanical fastening, etc.

In certain examples, including the example of FIGS. 19 and 20, body 210 has an axis of symmetry that is substantially perpendicular to the tangent plane in which distal-most point 214 of charm keeper 206 lies. This structure is also depicted in FIGS. 10 and 11. Body 210 is preferably a decorative ornament, and in FIGS. 19 and 20 is a pyramid. In certain examples, body 210 is selectively attachable to and detachable from shoe attachment portion 292a. However, in other examples (including FIGS. 19 and 20), body 210 is fixedly attached to shoe attachment portion 292a.

Referring to FIG. 21, another embodiment of a shoe 10 comprising a charm holder device 232 is depicted. In this embodiment, shoe 10 has a heel 14 that does not contact the ground. Shoe 10 includes a heel shank 12 between heel 14 and ground-contacting portion 21 of outsole 20 in a direction along the x-axis. In some cases, the shoe 10 of FIG. 21 may be referred to as a "heel-less" shoe because there is no ground contacting portion of the shoe beneath (in the y-axis direction) the location where the heel of the foot is positioned. However, for purposes of FIG. 21 the portion of shoe 10 spaced furthest from the toe section 28 in a direction along the x-axis may be referred to as a heel 14. Charm holder device 232 is substantially identical to the charm holder device of FIGS. 19-20. However, charm 144 on the shoe 10 of FIG. 21 is different than the charm 45 of FIG. 19.

Referring to FIG. 22, a further embodiment of a shoe 10 comprising a charm holder device 232 connected to charm 344 is depicted. The shoe 10 of FIG. 22 is a wedge shoe (shown with the vamp omitted) and does not include a heel shank that provides sufficient clearance to the ground to allow for the attachment of charm holder device 232. Charm holder device 232 is configured similarly to charm holder device 232 of FIGS. 19-20. In this example, a cut-out region 301 is formed which extends from the surface 300 of lateral side 15 to the opposing surface 302 (not shown) of medial side 17 (not shown) of shoe 10. Cut-out region 301 includes an inner surface 304 in the interior of the cut-out region 301.

Inner surface **304** includes a downward-facing portion **306** that faces in the direction of ground-contacting portion **21** of outsole **20** (i.e., downward-facing portion **306** is substantially parallel to the x-z plane). The shoe attachment portion **292a** (not separately shown in FIG. **22**) of charm holder device **232** is attached to the downward-facing portion **306** of cut-out region **301**. In this example, the surfaces **294** and **296** (not shown) of the shoe attachment portion **292a** are generally parallel to the ground-contacting portion **21** of outsole **20** and to the x-z plane. However, the cut-out region **301** could include sloped sidewalls, in which case the shoe attachment portion **292a** could be oriented at an angle with respect to ground-contacting portion **21** of outsole **20** as is the case in FIGS. **19** and **20**. Thus, in the example of FIG. **22**, charm **344** is swingable along both the x and z axis directions relative to outsole **20** and relative to charm holder device **232**.

The charm holder devices **32**, **232** described herein may be made of plastic, metal, or any other substantially rigid material. However, in preferred examples, the charm holder devices **32**, **232** include an outer surface with a metallic appearance. In certain examples, the outer surface comprises a non-tarnishing material. In the same or other examples, the outer surface has a shiny appearance. In one example, charm holder devices **32**, **232** are formed from a brass base material covered with a rhodium plating. In another example, the charm holder devices **32**, **232** are formed from a brass base material covered with a gold plating. In one example where a rhodium plating is used, the plating is silver and white in color.

As mentioned previously, charm holder devices **32**, **232** may be affixed to shoe **10** or selectively attachable to and detachable from it. In those examples where the charm holder devices are fixedly attached, the fixed attachment may be provided by mechanical or adhesive means. In fixed attachment examples wherein the shoe attachment portion **292a** is attached to a rubber, plastic, or fabric material on shoe **10**, adhesive attachment is preferable. In one example, a neoprene adhesive containing polychloroprene rubber is used. One such suitable adhesive is a Dual #88 Super Strength All Purpose Cement supplied by R-H Products, Co., Inc. of Acton, Mass. Other suitable adhesives include cyanoacrylate adhesives, one example of which is an ethyl cyanoacrylate adhesive sold under the name Gorilla Super Glue by the Gorilla Glue Company of Cincinnati, Ohio.

The charm holder devices **32**, **232**, and **332** (described below) may be applied to different shoes and at different shoe locations than those described previously. In general, the surface of the shoe to which the charm holder device **32**, **232** is attached will preferably have a surface normal (i.e., axis perpendicular to the surface) that is not parallel to the ground-contacting portion **21** of outsole **20**. The surface normal preferably comprises a component that is perpendicular to the ground contacting portion **21** of the shoe. In other words, the surface normal is the vector sum of two component vectors, one of which is perpendicular to ground-contacting portion **21**. For example, in FIGS. **19** and **20**, shoe attachment portion **292a** of charm holder device **232** is attached to the heel shank **12**. The heel shank **12** has a surface normal vector  $n$  that can be resolved into two component vectors, one of which is parallel to the y-axis ( $n_y$ ), and the other of which is parallel to the x-axis ( $n_x$ ). The vector parallel to the y-axis ( $n_y$ ) is perpendicular to ground-contacting portion **21** of outsole **20**. This orientation allows the charm attached to the charm holder device **32**, **232** to hang freely and swing, at least to some extent.

Referring to FIG. **23a**, shoe **10** is depicted with another example of a charm holder device **332** to which selectively detachable charm **44** is attached. The elements of shoe **10** are the same as those depicted in FIGS. **19-20** except for the charm holder device **332**. Charm holder device **332** may be used with other shoe styles as well, including shoes that lack a heel such as the shoe **10** depicted in FIG. **21**.

In the example of FIG. **23a**, shoe **10** comprises a charm holder device **332** attached to a portion of the shoe **10**. In FIG. **23a**, charm holder device **332** is attached to the outsole **20** at a location that is spaced apart from the ground-contacting portion **21** of outsole **20** along both the x-axis and the y-axis. In the depicted example, the charm holder device **332** is located between the heel **14** and ground-contacting outsole portion **21** along the length axis of the shoe, which is the x-axis in FIG. **23a**. Any style of charm may be used. To illustrate the operation of the charm holder device **332**, charm **44** is depicted. Charm **44** comprises a decorative object **46** in the shape of a sphere, a chain **50**, and a clasp **49**. The chain **50** is connected to the decorative object **46** at a first end and to clasp **49** at a second end. The clasp **49** is selectively openable and closable. When clasp **49** is in an open configuration, it is engageable with charm keeper **406**. Once engaged, the clasp **49** can be adjusted to a closed configuration for secure retention to charm keeper **406**. In FIGS. **23a-26**, the orientations of the components of shoe **10** relative to one another are defined using x, y, and z axes, while the orientations of the components of the charm holder device **332** relative to one another are defined using i, j, and k axes. Once the charm holder device **332** is installed on a shoe, the two coordinate systems (x, y, z) and (i, j, k) will have a fixed relationship to one another. In general, the charm holder device **332** may be located at the shank **12** or the heel breast **31**, but is located at shank **12** in FIGS. **23a** and **23b**.

In the example of FIG. **23a**, the surface of outsole **20** at which the charm holder device **332** is located has a surface normal  $n$  that is not parallel to the ground-contacting surface **21** of outsole **20**, and thus, is not perpendicular to a surface normal to the ground-contacting surface **21**. As illustrated, the surface normal to the portion of the outsole at which the charm holder device **332** is located is also not parallel to the surface normal to the ground-contacting surface **21** of outsole **20**. In the example of FIG. **23a**, charm **44** can swing freely along the lateral to medial (or width) axis of the shoe **10**, which is depicted as the z-axis as well as along the shoe length axis (x-axis). However, charms may be attached to the charm holder device **332** which would not swing along either or both of the x and y axes.

Referring now to FIG. **24**, the charm holder device **332** of FIG. **23a** is shown in greater detail in a bottom plan view. Charm holder device **332** comprises a shoe engaging portion **392** and a charm keeper **406**. The shoe engaging portion **392** comprises a base plate **393**, a first stake **414a**, and a second stake **414b**. The first stake and second stake each comprise respective first ends **415a** and **415b** (FIGS. **25a**, **25b**) which are each attached to the base plate **393** and respective second ends **416a** and **416b** which are spaced apart from the base plate **393**. The respective first ends **415a** and **415b** of stakes **414a** and **414b** are spaced apart from one another along the i axis (FIGS. **25a**, **25b**). While the stakes **414a** and **414b** are depicted in FIGS. **24** and **25a** as comprising linear segments **417a/419a** and **417b/419b** that have an unvarying width along the i axis, other stake shapes may be used including those with variable i axis widths. Base plate **393** comprises an upper surface **394**, a lower surface **396**, and a side surface **398** that defines the perimeter of the base plate **393**. Base

plate **393** has a circular profile when viewed along the *j* axis in FIG. **24**. However, other profiles such as squares, rectangles, triangles, and irregular shapes may also be used. The upper and lower base plate surfaces **394** and **396** may have the same or different profiles.

In certain examples, base plate **393** is dimensioned so that its longest dimension is shorter than the spacing along outsole **20** between the lateral side **15** and medial side **17** (i.e., along the *z*-axis) of a shoe. The total linear lengths of the stakes **414a** and **414b** (i.e., the sum of the lengths of first region **417a** and second region **419a** for stake **414a** and the sum of the lengths of first region **417b** and second region **419b** for stake **414b**) are preferably greater than the thickness between the outsole **20** and the insole **18** and preferably less than the distance along the outsole **20** from the lateral side **15** to the medial side **17** of the shoe **10** at the location on the outsole **20** where the charm holder device **332** is placed.

In the example of FIGS. **25a** and **25b**, the respective first ends **415a** and **415b** of the first and second stakes **414a** and **414b** are attached to an upper surface **394** of the base plate **393**. A charm keeper **406** is also attached to the base plate **393** and projects away from the base plate **393** in a direction along the *j* axis. Thus, the respective first ends **415a** and **415b** of the stakes **414a** and **414b** are spaced apart from the charm keeper **406** along the *j* axis. In the example of FIGS. **24a-25b**, the first ends **415a** and **415b** of first and second stakes **414a** and **414b** are not spaced apart from one another along the *i* axis. However, in certain examples, they may be.

The charm holder device **332** is adjustable between multiple configurations that define unique geometric relationships between the stakes **414a** and **414b** and the base plate **393**. Two such configurations are depicted in FIGS. **25a** and **25b**. In the first configuration of FIG. **25a**, the first and second stakes **414a** and **414b** are in a first configuration in which their respective second ends **416a** and **416b** are spaced apart from the base plate **393** by a first distance  $d_3$  (or respective first distances) along the *j* axis. In the second configuration of FIG. **25b**, the first and second stakes **414a** and **414b** are in a second configuration in which their respective second ends **416a** and **416b** are spaced apart from the base plate **393** by a second distance  $d_4$  (or respective second distances) along the *j* axis, wherein the first distance is greater than the second distance.

As illustrated in FIGS. **25a** and **25b**, in certain examples, in the first configuration (FIG. **25a**), the respective second ends **416a** and **416b** of the stakes **414a** and **414b** are spaced apart from one another along the *i* axis by a first distance  $d_1$ , and in the second configuration (FIG. **25b**), the respective second ends **416a** and **416b** are spaced apart from one another along the *i* axis by a second distance  $d_2$ , and the second distance is greater than the first distance.

To allow the first and second stakes **414a** and **414b** to be adjusted between the first and second configurations, the first stake **414a** is bendable about a first bending axis  $B_{1a}$  that is parallel to the *k* axis. The second stake **414b** is bendable about a second bending axis  $B_{1b}$  that is also parallel to the *k* axis. The two bending axes  $B_{1a}$  and  $B_{1b}$  are spaced apart from one another along the *i* axis. In certain examples, the bending axes  $B_{1a}$  and  $B_{1b}$  are spaced apart from the upper surface **394** of the base plate **393** by a distance  $d_4$  (or respective distances) along the *j* axis. The first stake **414a** and second stake **414b** are preferably bendable about their respective bending axes  $B_{1a}$  and  $B_{1b}$  using manual pressure without the assistance of any tools. In preferred examples, the materials of construction of the stakes **414a** and **414b** and the dimensions of the stakes **414a** and **414b** are selected

to make the stakes **414a** and **414b** bendable about their respective first bending axes  $B_{1a}$  and  $B_{1b}$ . In one example, the stakes **414a** and **414b** have thicknesses along the *j* axis that are preferably no greater than about 2 mm, more preferably no greater than about 1.5 mm, and still more preferably no greater than about 1.0 mm. In the same or other examples, the thicknesses along the *j* axis are preferably at least about 0.3 mm, more preferably at least about 0.4 mm, and still more preferably at least about 0.6 mm. In the same or other examples, the stakes **414a** and **414b** have a width along the *k* axis direction that is no greater than about 4 mm, preferably no greater than about 2 mm, and still more preferably no greater than about 1.5 mm. In the same or other examples, the widths along the *k* axis are preferably no less than about 0.5 mm, more preferably no less than about 0.6 mm, and still more preferably no less than about 0.8 mm.

In the same or other examples, the total linear lengths of each of the stakes **414a** and **414b** (i.e., the lengths if the stakes **414a** and **414b** were completely flat) are preferably no more than about 20 mm, more preferably no more than about 15 mm, and still more preferably no more than about 12 mm. In the same or other examples, the total linear lengths are preferably at least about 5 mm, more preferably at least about 6 mm, and still more preferably at least about 8 mm.

In certain examples, and as shown in FIGS. **25a** and **25b**, the first and second stakes **414a** and **414b** are also bendable about second respective bending axes  $B_{2c}$  and  $B_{2d}$ . The first bending axis  $B_{2c}$  divides first stake **414a** into a first region **417a** and a second region **419a**, wherein the first region **417a** is disposed between the second region **419a** and the base plate **393**. The second bending axis  $B_{2d}$  divides second stake **414b** into a first region **417b** and a second region **419b** wherein the first region **417b** is disposed between the second region **419b** and the base plate **393**. Bending axis  $B_{2c}$  and  $B_{2d}$  are parallel to one another and are also parallel to the first bending axes  $B_{1a}$  and  $B_{1b}$ .

Bending each stake **414a** and **414b** about its respective second bending axis  $B_{2c}$  and  $B_{2d}$  changes the angle defined between each stake's respective first and second regions. Thus, bending stake **414a** about bending axis  $B_{2c}$  alters the angle between first region **417a** and second region **419a** of first stake **414a**. Correspondingly, bending stake **414b** about bending axis  $B_{2d}$  alters the angle between first region **417b** and second region **419b** of second stake **414b**. Bending the stakes **414a** and **414b** about their respective second bending axes  $B_{2c}$  and  $B_{2d}$  also allows the distance between each stake's second end **416a** and **416b** and corresponding first end **415a** and **415b** to be adjusted. For example, if the charm holder device **332** is in the configuration of FIG. **25a** and the stakes **414a** and **414b** are bent about their respective second bending axes  $B_{2c}$  and  $B_{2d}$  without also bending the stakes about their respective first bending axis  $B_{1a}$  and  $B_{1b}$ , the spacing between each stake's second end **416a** and **416b** and corresponding first end **415a** and **415b** will be altered. However, the angles defined between each stake's first region **417a** and **417b** and the base plate **393** will not be altered. While the stakes **414a** and **414b** may be manufactured with the distal ends **416a** and **416b** projecting inwardly toward one another along the *x*-axis for ease of packaging, they need not be. In certain examples, the charm holder device **332** is provided in an initial configuration prior to installation on shoe **10** in which the stakes **414a** and **414b** are substantially straight, and may or may not be oriented perpendicularly to upper surface **394** of base plate **393**.

Charm holder device **332** also includes a charm keeper **406** attached to the shoe engaging portion **392**. In the

example of FIGS. 24-25b, the charm keeper is attached to lower surface 396 of base plate 393. Charm keeper 406 is shaped to receive and engage a portion of a charm, such as a loop or a selectively openable and closeable clasp. In the example of FIGS. 24-25b, the charm keeper 406 is affixed to the base plate 393 and cannot be opened or closed. However, in other examples, charm keeper 406 may be selectively opened and closed to receive and engage charms.

In the example of FIGS. 24-25b, the charm keeper 406 comprises a member having a first end 412a and a second end 412b which are attached to locations on base plate 393 that are spaced apart from one another along the k axis. In the depicted example, the locations on base plate 393 to which the first and second ends 412a and 412b of the charm keeper 406 are attached are not spaced apart from one another along either the i axis or the j axis. However, in certain examples, they may be spaced apart along either or both the i and j axes. In the depicted example, the charm keeper 406 has a length along the k axis and a width along the i axis, wherein the length is greater than the width. Thus, as depicted, the length axis of the charm keeper 406 is parallel to the axis defined by the spacing between the first stake ends 415a and 415b. However, the two axes may be perpendicular to one another or oriented at non-orthogonal angles relative to one another.

Charm keeper 406 preferably projects away from the base plate 393, and more preferably, projects away from the base plate 393 and away from the respective first ends 415a and 415b of stakes 414a and 414b in a direction along the j axis. As a result, when viewed along the i axis (FIGS. 25a, 25b), charm keeper 406 defines an opening 407 between the charm keeper 406 and the base plate 393. The opening 407 provides a location for inserting a component of a charm to engage the charm to the charm keeper 406. For example, hooks or clasps may be inserted through opening 407 to retain a charm to the charm keeper 406.

In the example of FIGS. 24-25b, charm keeper 406 includes a peak 418 between the charm keeper first end 412a and second end 412b. The peak 418 is spaced apart from the base plate 393 along the j axis and is the location of maximum spacing between the charm keeper 406 and the base plate 393 along the j axis. In certain examples, the peak 418 is spaced apart from each of the charm keeper ends 412a and 412b by the same or substantially same distance along the k axis.

In certain examples, the charm holder device 332 is designed to provide additional space along the j axis to receive a charm. As best seen in FIG. 24, the base plate 393 includes an opening 410 that extends through the upper surface 394 and the lower surface 396 of the base plate 393. The opening 410 has a length along the k axis and a width along the i axis, wherein the length is greater than the width. As best seen in FIG. 24, in certain preferred examples, the width of opening 410 along the i axis is greater than the width of the charm keeper 406 along the i axis. The portion of a charm that engages the charm keeper 406 will generally have a width that is no less than the width of the charm keeper 406 along the i axis to ensure secure retention of the charm. When the charm is engaged to the charm keeper 406, the portion of the charm engaging the charm keeper 406 may also have a height above the charm keeper 406 along the j axis. Thus, providing opening 410 with an i axis width greater than the i axis width of the charm keeper 406 allows the portion of the charm that engages the charm keeper 406 to fit into the additional j axis space created by opening 410. Otherwise, the maximum j axis spacing available for a charm to engage the charm keeper 406 would be defined by

the j axis distance between the lower surface 396 of base plate 393 and the peak 418 of the charm keeper 406. Instead, when opening 410 is provided, the maximum j axis spacing available for a charm to engage the charm keeper 406 is defined by the distance between the outsole 20 (FIGS. 23a-23b) of the shoe and the charm keeper peak 418.

In the example of FIG. 24, the width of opening 410 along the i axis defines first and second i axis clearances  $\Delta i_1$  and  $\Delta i_2$  which may be same or different from one another, but which are substantially equal in FIG. 24. In the example of FIG. 24, the k axis length and i axis width of opening 410 are positioned symmetrically about the center of the base plate 393 in the i-k plane. However, in other examples, asymmetrical configurations may be provided. As illustrated in FIG. 24, the length of the opening 410 along the k axis is the same or substantially the same as the length of the charm keeper 406 along the k axis, but in other examples, the two lengths may differ.

The charm holder device 332 may be formed from a variety of different materials, including plastics and metals. In preferred example, the charm holder device 332 is formed from a material or materials that will not wear or tarnish despite prolonged use on the sole of the shoe during which the charm holder device 332 is exposed to the elements.

In one example, at least one of the base plate 393, charm keeper 406, and first and second stakes 414a and 414b comprises metal materials. In another example, each of the base plate 393, charm keeper 406, and first and second stakes 414a and 414b comprises metal materials. In yet another example, at least one of the base plate 393, charm keeper 406, and first and second stakes 414a and 414b consists essentially of metal materials. In still another example, each of the base plate 393, charm keeper 406, and first and second stakes 414a and 414b consists essentially of metal materials. In another example, each of the base plate 393, charm keeper 406, and first and second stakes 414a and 414b comprises the same metal material. In further examples, each of base plate 393, charm keeper 406, and first and second stakes 414a and 414b consists essentially of the same metal material. In the example shown in FIGS. 24-25b, each of the base plate 393, charm keeper 406, and first and second stakes 414a and 414b consists essentially of nickel. In other examples, each of the base plate 393, charm keeper 406, and first and second stakes 414a and 414b consists essentially of a brass base material covered with rhodium.

A variety of different techniques may be used to form the charm holder device 332. In one example, the base plate 393 and charm keeper 406 are cast out of a metal, preferably nickel, to integrally form a portion of the charm holder device 332 comprising the base plate 393 and charm keeper 406. The stakes 414a and 414b are separately cast and then attached to the base plate 393 such as by welding or soldering in a manner that makes the stakes 414a and 414b bendable about their respective first bending axes  $Bi_a$  and  $Bi_b$ . In another example, the entire charm holder device 332 is integrally formed as a single piece, such as by casting.

A method of providing a shoe 10 comprising charm holder device 332 will now be described with reference to FIG. 26. In accordance with the method, a shoe sole is provided which comprises an outsole 20 and an insole 18. The outsole 20 will be exposed and will face the ground when the shoe is in use. Two openings 19a and 19b are drilled through the sole from the outsole 20 to the insole 18 (FIG. 26) and are spaced apart by a distance that is the same or substantially the same as the distance between the respective first ends 415a and 415b of the first and second stakes

414a and 414b along the k axis of the charm holder device 332. In the example of FIG. 26, the openings 19a and 19b are spaced apart from one another along the axis defined between the lateral side 15 and medial side 17 of the shoe 10, which is the z axis of the shoe 10 in FIG. 26. Thus, in FIG. 26 the i axis of the charm holder device 332 is parallel or substantially parallel to the z-axis of the shoe 10 (of FIG. 23b).

Charm holder device 332 is provided in the configuration of FIG. 25a, but as indicated previously, the stakes 414a and 414b may be substantially straight and not bent about second bending axes  $Bi_c$  and  $Bi_a$ . The respective second ends 416a and 416b of stakes 414a and 414b are inserted through a respective opening 19a and 19b in outsole 20 and insole 18. To facilitate the insertion, each stake 414a and 414b may be bent about its respective second bending axis  $Bi_c$  and  $Bi_a$  to rotate first stake second region 419a away from second stake second region 419b and increase the angle defined between first region 417a and second region 419a of first stake 414a and the angle defined between the first region 417b and second region 419b of second stake 414b. The rotation will increase the k axis spacing between the respective second ends 416a and 416b of the first stake 414a and second stake 414b and will generally cause the stakes 414a and 414b to assume a straighter configuration. The stakes 414a and 414b may also be rotated about their first bending axes  $Bi_a$  and  $Bi_b$ , so that each stake's first region 417a and 417b is perpendicular or substantially perpendicular to the upper surface 394 of base plate 393 to facilitate insertion into outsole openings 19a and 19b.

Once the stakes 414a and 414b are inserted through the outsole openings 19a and 19b, each stake 414a and 414b may be further rotated about its first bending axis  $Bi_a$  and  $Bi_b$ , so that their respective second stake ends 416a and 416b are rotated away from one another to the configuration of FIG. 25b. The stakes 414a and 414b are then partially or wholly flattened or substantially flattened into abutting engagement with the insole 18 (FIG. 26). A portion of an upper 33 that covers the top of the foot and/or a sock insole lining (if the upper is to be done as a sandal) is then adhesively attached to and applied over the insole 18 to conceal the stakes 414a and 414b from view. Heel 14 is then attached to outsole 20 such as by using glue and/or mechanical fasteners (e.g., a nail).

Accordingly, it is to be understood that the embodiments of the invention herein described are merely illustrative of the application of the principles of the invention. Reference herein to details of the illustrated embodiments is not intended to limit the scope of the claims, which themselves recite those features regarded as essential to the invention.

What is claimed is:

1. A shoe, comprising: an outsole having an inner surface, an outer surface, a first portion, and a second portion, wherein the first portion is a ground-contacting portion, and the second portion is spaced apart from the ground contacting portion along a shoe height axis; and

a charm holder device attached to the second portion of the outsole, the charm holder device comprising: a base plate having an upper surface and a lower surface; first and second stakes attached to the base plate, wherein the first and second stakes have respective first ends attached to the base plate and respective second ends spaced apart from the base plate, the first and second stakes are bendable about respective first and second bending axes, and the first and second bending axes are parallel to the base plate lower surface and spaced apart

from the base plate lower surface; and a charm keeper projecting away from the lower surface of the base plate.

2. The shoe of claim 1, wherein the charm keeper comprises a member having first and second ends attached to the base plate lower surface, the first and second member ends are spaced apart from one another along a third axis, and the member comprises a central portion spaced apart from the base plate lower surface along a fourth axis.

3. The shoe of claim 1, wherein the charm keeper defines an opening between the charm keeper and the base plate.

4. The shoe of claim 1, wherein the first and second stakes have a first configuration, wherein when the first and second stakes are in the first configuration, the second end of the first stake is spaced apart from the second end of the second stake by a first distance along a third axis.

5. The shoe of claim 4, wherein the first and second stakes have a second configuration, wherein when the first and second stakes are in the second configuration, the second end of the first stake is spaced apart from the second end of the second stake by a second distance along the third axis, and the second distance is greater than the first distance.

6. The shoe of claim 5, wherein when the first and second stakes are in the first configuration, the second ends of the first and second stakes are spaced apart from the upper surface of the base plate by a third distance along a fourth axis, and when the first and second stakes are in the second configuration, the second ends of the first and second stakes are spaced apart from the upper surface of the base plate by a fourth distance along the fourth axis, and the third distance is greater than the fourth distance.

7. The shoe of claim 1, wherein the first and second stakes are bendable about respective third and fourth bending axes, and the respective third and fourth bending axes are parallel to the first and second bending axes.

8. The shoe of claim 1, wherein the respective first ends of the first and second stakes are attached to the upper surface of the base plate.

9. The shoe of claim 1, wherein the respective first ends of the first and second stakes are spaced apart from one another along a third axis.

10. The shoe of claim 1, wherein the respective first and second bending axes are spaced apart from the upper surface of the base plate.

11. The shoe of claim 1, wherein the base plate comprises an opening extending from the lower surface of the base plate to the upper surface of the base plate.

12. The shoe of claim 11, wherein the charm keeper has a length and a width, the charm keeper length is greater than the charm keeper width, the opening has a length and a width, the opening length is greater than the opening width, and the opening width is greater than the charm keeper width.

13. The shoe of claim 12, wherein the base plate, the first stake, and the second stake consist essentially of nickel.

14. The shoe of claim 1, further comprising a heel spaced apart from the ground contacting portion of the outsole along a shoe length axis, wherein the second portion of the outsole is located between the heel and the ground-contacting portion of the outsole along the shoe length axis.

15. The shoe of claim 1, wherein the second portion of the outsole is oriented at a non-orthogonal angle relative to the ground-contacting portion of the outsole.

16. The shoe of claim 1, wherein the first and second stakes of the charm holder device extend through the outer surface and the inner surface of the outsole.

17. The shoe of claim 1, wherein the respective first and second ends of the first and second stakes project away from one another.

18. The shoe of claim 17, wherein the respective first ends of the first and second stakes are spaced apart from one another along a third axis that is perpendicular to the first bending axis and the second bending axis. 5

19. The shoe of claim 1, further comprising a charm having a charm clasp, wherein the charm clasp has an open configuration and a closed configuration, and the charm clasp engages the charm keeper and is in the closed configuration. 10

20. The shoe of claim 1, wherein the first and second stakes comprise metal materials.

21. The shoe of claim 1, wherein the first and second stakes consist essentially of metal materials. 15

22. The shoe of claim 1, wherein the first and second bending axes are spaced apart from the base plate lower surface in a direction parallel to the lower surface.

\* \* \* \* \*