

Nov. 30, 1971

K. F. W. LEBEN

3,623,406

SNOW COMPACTING ROLLER

Filed Jan. 29, 1970

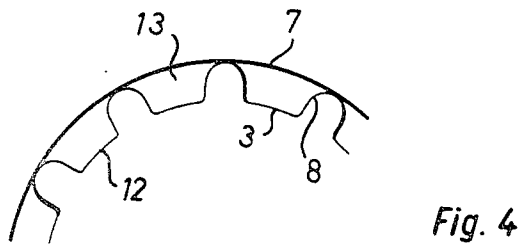
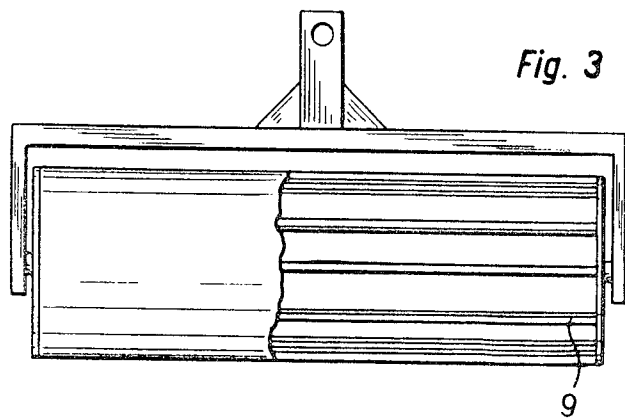
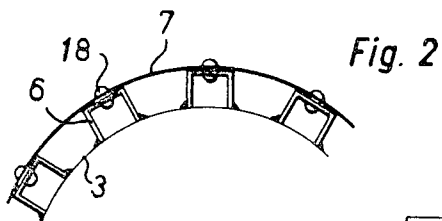
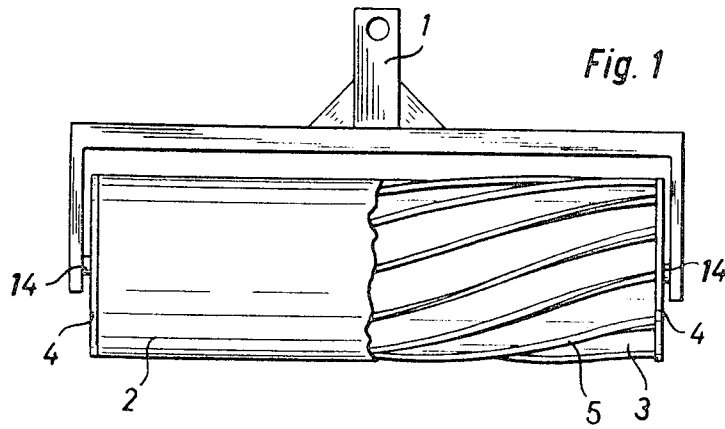

1

2

3,623,406

**SNOW COMPACTING ROLLER**

Klaus F. W. Leben, Berg, Germany, assignor to Leben & Co. KG Vertrieb von Pistenpflegegeräten für Skiabfahrten, Munich, Germany

Filed Jan. 29, 1970, Ser. No. 6,687

Claims priority, application Germany, Feb. 2, 1969, P 19 06 130.4

Int. Cl. E01c 19/24

U.S. Cl. 94—50 R

7 Claims

**ABSTRACT OF THE DISCLOSURE**

A roller drum to be towed behind an over-snow vehicle for preparing and conditioning ski runs. The roller drum has a flexible outer sheath which rests in contact only over a limited area of the drum construction so that snow which adheres temporarily to the working surface of the sheath falls off, due to the elastic movement of the flexible sheath.

The invention relates to a roller drum adapted to be towed behind an over-snow vehicle for preparing and conditioning ski runs, whereby the snow is pressed together, so as to improve the quality of the ski run and increase its durability.

Known vehicles used for this purpose are usually equipped with two power driven caterpillar tracks spaced each other which serve both for propelling the vehicle and for compacting the snow. The snow between the caterpillar tracks is compacted by a roller drum trailed behind the vehicle. However it is found that caterpillar tracks used in this way for compacting snow tend to tear the snow to pieces at the same time leaving a rough surface.

Consequently the trailing roller drum, whose purpose is to roll down the areas of snow which have not been compacted by the caterpillar tracks, that is to say the snow between the caterpillar tracks and—depending on the length of the roll—on either side of the vehicle, also has to equalize the snow surface where it has been torn by the caterpillar tracks of the towing vehicle.

The known roller drums used for this purpose have the disadvantage that when the snow is sticky it adheres to the surface of the roller drum, preventing the formation of a smooth snow surface.

It is therefore the principal object of the present invention to provide a roller drum with a working surface to which the snow does not adhere.

Subject matter of the invention: a flexible outer tubular sheath is stretched over a drum so that it rests in contact only over limited areas with the surface of the drum to this end, the drum is formed with projecting ribs or with domes so that any snow which adheres temporarily to the surface of the sheath falls off, due to the elastic movements of the flexible sheath. The drum, intended to towed, has a length which is substantially greater than its diameter.

These and other objects of the invention will become apparent from the following description, having reference to the annexed drawing, wherein:

FIG. 1 is a plan view of a roller drum according to the invention,

FIG. 2 is a cross section through a section of the roller drum,

FIG. 3 shows a second execution form of the roller drum according to the invention,

FIG. 4 is a cross section through a section of a still further variant of the roller drum according to the invention.

In FIG. 1 a roller drum 2 substantially longer than its diameter; is rotatably supported in bearings 14 in a forked

frame 1 arranged to be towed behind an over-snow vehicle. The roller drum 2 comprises a hollow sheet metal cylinder 3 closed at both ends by end plates 4, which are joined to the sheet metal cylinder 3 by any suitable sealing means so that no snow can penetrate into the interior of the drum.

The outer surface of the hollow metal cylinder 3 has external spacing means in the form of helical ribs 5. As shown in FIG. 2, each rib 6 has a square cross section and is formed by an U-shaped channel welded along its edges to the outer surface of the hollow cylinder 3. The helical ribs help to stiffen the hollow cylinder.

The working surface of the drum is a flexible, elastic outer skin or sheath 7, preferably made of rubber or plastic material, which comes into contact with the snow. The sheath 7 is attached to the helical ribs 6 by a plurality of rivets 18. The rivets are not necessary. If no rivets are used, the sheath merely rests as a tight fit on the ribs, held in place only by elastic tension. The flexible sheath has the form of an elastic tube tight under tension over the ribs or other spacing means, whereby the sheath is fixed by prestressing of the sheath material.

In operation, the flexible, elastic sheath 7 has a certain amount of elastic freedom of movement between the ribs 6, preventing the snow from remaining adhering to the surface of the sheath, due to elastic movement of the sheath.

The drum shown in FIG. 3 contains projecting ribs 9 which are not helical, but extend in straight lines, axially with respect to the cylinder. This arrangement functions essentially in the same way, but does not have the same stiffening effect as the helical ribs.

The outwardly projecting ribs 8 could also be formed as integral parts of the drum cylinder 12, as shown in FIG. 4.

The ribs need not necessarily extend continuously along the drum. It is possible to provide short projections, or even merely rounded bumps projecting outwards from the surface of the cylinder, leaving spaces in between where the sheath 7 can flex resiliently. For example round or elongated domes 8 can be pressed out in the surface of the hollow cylinder 3 and distributed over the surface. It is necessary that the elastic or resilient sheath 7 has sufficient room to flex between the individual projections or domes 8, but must not be allowed to come into contact with the main outer surface 12 of the cylinder 3, in other words there must always remain hollow intermediate spaces 13.

At the two ends of the drum the sheath 7 is sealed to the drum so that no snow can penetrate into the intermediate spaces 13, interfering with the elastic movements of the sheath 7. The tight seal between the sheath and the drum, at the two ends of the drum, can be obtained for example by means of rubber sleeves or discs or any other conventional means to close the ends of the drum and the space between the ribs to prevent snow from entering the drum or between the drum and the spaces.

While there have been described and illustrated preferred embodiments of the above invention it is apparent that numerous alterations, omissions and additions may be made without departing from the spirit there.

Accordingly, what is claimed is:

1. Trailing roller adapted to be towed behind an over-snow vehicle for compacting snow and particularly for preparing and conditioning ski runs, comprising

a hollow elongated drum having an axial length substantially longer than its diameter formed with projecting spacers extending from the outer circumference of the drum;

a flexible, resilient snow impervious sheath tube surrounding said drum to form a smooth, flexible work-

3

ing surface at the outside thereof, said tube being stretched over the drum and secured to the drum by tension of the elastic tube material against said projecting spacers extending from the outer circumference of the drum,

the spacers between the tube and the drum circumference extending over limited areas of the drum circumference so that, upon towing of said roller over a snow surface, the roller will compact snow to an essentially smooth surface and snow adhering to the outside of the sheath tube, forming the snow compacting and working surface, falling off due to resilient movement of the tube between the projecting spacers, means at the ends of the drum to close the ends of the drum and the space between the drum and the sheath tube to prevent snow from entering; and means secured to the drum to enable the roller to be towed.

2. Roller drum as claimed in claim 1, wherein said tube is sealed at its ends to the drum to prevent penetration of snow between said flexible tube and said drum.

3. Roller as claimed in claim 1, wherein the spacers are ribs fixed to the cylindrical wall of the hollow drum, projecting outwardly therefrom and extending substantially in axial direction from one end to the other of the drum.

4

4. Roller as claimed in claim 3, wherein said ribs extend helically over the surface of said drum.

5. Roller as claimed in claim 3, wherein said ribs extend in axial direction about said drum.

6. Roller as claimed in claim 1, wherein the projecting spacers are formed as integral projections from the cylindrical wall of the drum.

7. Roller as claimed in claim 1, wherein the projecting spacers are domes spaced from each other and pressed out of the cylindrical wall of the drum.

**References Cited**

**UNITED STATES PATENTS**

|    |           |         |            |         |
|----|-----------|---------|------------|---------|
| 15 | 1,425,334 | 8/1922  | Pedroarena | 301—41  |
|    | 2,261,893 | 11/1941 | Wolfard    | 94—50   |
|    | 2,668,736 | 2/1954  | Poche      | 301—41  |
|    | 2,824,592 | 2/1958  | Neisler    | 94—50 X |
|    | 3,233,530 | 2/1966  | Brebner    | 94—50 X |
| 20 | 3,370,889 | 2/1968  | Tucker     | 301—41  |

JACOB L. NACKENOFF, Primary Examiner

U.S. Cl. X.R.

25 301—41