

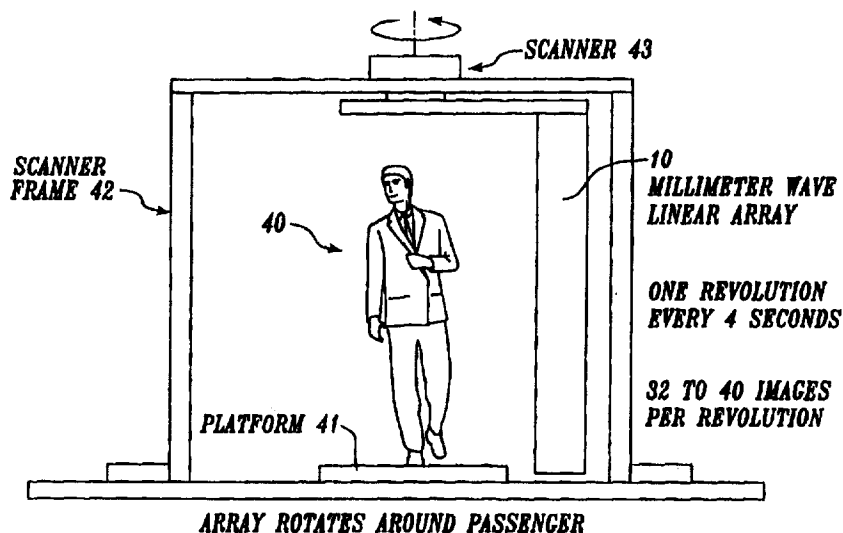

INTERNATIONAL APPLICATION PUBLISHED UNDER THE PATENT COOPERATION TREATY (PCT)

<p>(51) International Patent Classification ⁶ : G01S 13/89, G06T 11/00, A61B 5/05</p>	<p>A1</p>	<p>(11) International Publication Number: WO 98/11453</p> <p>(43) International Publication Date: 19 March 1998 (19.03.98)</p>
<p>(21) International Application Number: PCT/US97/15723</p> <p>(22) International Filing Date: 5 September 1997 (05.09.97)</p> <p>(30) Priority Data: 08/714,026 11 September 1996 (11.09.96) US</p> <p>(71) Applicant: BATTELLE MEMORIAL INSTITUTE [US/US]; Pacific Northwest Division, Intellectual Property Services, P.O. Box 999, Richland, WA 99352 (US).</p> <p>(72) Inventors: SHEEN, David, M.; 1164 Viewmont Court, Richland, WA 99352 (US). McMAKIN, Douglas, L.; 2173 Shasta Avenue, Richland, WA 99352 (US). HALL, Thomas, E.; 8301 W. Entiat Place, Kennewick, WA 99336 (US). SEVERTSEN, Ronal, H.; 1803 Birch Avenue, Richland, WA 99352 (US).</p> <p>(74) Agent: ZIMMERMAN, Paul, W. (K1-53); Battelle Memorial Institute, Pacific Northwest Division, Intellectual Property Services, P.O. Box 999, Richland, WA 99352 (US).</p>		<p>(81) Designated States: AL, AM, AT, AU, AZ, BA, BB, BG, BR, BY, CA, CH, CN, CU, CZ, DE, DK, EE, ES, FI, GB, GE, HU, IL, IS, JP, KE, KG, KP, KR, KZ, LC, LK, LR, LS, LT, LU, LV, MD, MG, MK, MN, MW, MX, NO, NZ, PL, PT, RO, RU, SD, SE, SG, SI, SK, TJ, TM, TR, TT, UA, UG, UZ, VN, ARIPO patent (GH, KE, LS, MW, SD, SZ, UG, ZW), Eurasian patent (AM, AZ, BY, KG, KZ, MD, RU, TJ, TM), European patent (AT, BE, CH, DE, DK, ES, FI, FR, GB, GR, IE, IT, LU, MC, NL, PT, SE), OAPI patent (BF, BJ, CF, CG, CI, CM, GA, GN, ML, MR, NE, SN, TD, TG).</p> <p>Published <i>With international search report.</i></p>

(54) Title: REAL-TIME WIDEBAND CYLINDRICAL HOLOGRAPHIC SURVEILLANCE SYSTEM



(57) Abstract

A wideband holographic cylindrical surveillance system including a transceiver for generating a plurality of electromagnetic waves; antenna for transmitting the electromagnetic waves toward a target at a plurality of predetermined positions in space; the transceiver also receiving and converting electromagnetic waves reflected from the target to electrical signals at a plurality of predetermined positions in space; a computer for processing the electrical signals to obtain signals corresponding to a holographic reconstruction of the target; and a display for displaying the processed information to determine nature of the target. The computer has instructions to apply Fast Fourier Transforms and obtain a three-dimensional cylindrical image.

FOR THE PURPOSES OF INFORMATION ONLY

Codes used to identify States party to the PCT on the front pages of pamphlets publishing international applications under the PCT.

AL	Albania	ES	Spain	LS	Lesotho	SI	Slovenia
AM	Armenia	FI	Finland	LT	Lithuania	SK	Slovakia
AT	Austria	FR	France	LU	Luxembourg	SN	Senegal
AU	Australia	GA	Gabon	LV	Latvia	SZ	Swaziland
AZ	Azerbaijan	GB	United Kingdom	MC	Monaco	TD	Chad
BA	Bosnia and Herzegovina	GE	Georgia	MD	Republic of Moldova	TG	Togo
BB	Barbados	GH	Ghana	MG	Madagascar	TJ	Tajikistan
BE	Belgium	GN	Guinea	MK	The former Yugoslav Republic of Macedonia	TM	Turkmenistan
BF	Burkina Faso	GR	Greece	ML	Mali	TR	Turkey
BG	Bulgaria	HU	Hungary	MN	Mongolia	TT	Trinidad and Tobago
BJ	Benin	IE	Ireland	MR	Mauritania	UA	Ukraine
BR	Brazil	IL	Israel	MW	Malawi	UG	Uganda
BY	Belarus	IS	Iceland	MX	Mexico	US	United States of America
CA	Canada	IT	Italy	NE	Niger	UZ	Uzbekistan
CF	Central African Republic	JP	Japan	NL	Netherlands	VN	Viet Nam
CG	Congo	KE	Kenya	NO	Norway	YU	Yugoslavia
CH	Switzerland	KG	Kyrgyzstan	NZ	New Zealand	ZW	Zimbabwe
CI	Côte d'Ivoire	KP	Democratic People's Republic of Korea	PL	Poland		
CM	Cameroon	KR	Republic of Korea	PT	Portugal		
CN	China	KZ	Kazakstan	RO	Romania		
CU	Cuba	LC	Saint Lucia	RU	Russian Federation		
CZ	Czech Republic	LI	Liechtenstein	SD	Sudan		
DE	Germany	LK	Sri Lanka	SE	Sweden		
DK	Denmark	LR	Liberia	SG	Singapore		
EE	Estonia						

5

**REAL-TIME WIDEBAND CYLINDRICAL
HOLOGRAPHIC SURVEILLANCE SYSTEM**

FIELD OF THE INVENTION

The present invention relates to a method and apparatus
10 useful for inspection of concealed objects. More
specifically, the present invention relates to forming a
cylindrical image with millimeter wave signals that are
transmitted and received by a holographic array and that are
reconstructed using Fast Fourier Transform Analysis. The
15 method and apparatus have particular utility for personnel
inspection in mass transportation centers.

BACKGROUND

20 The need for a new and more versatile personnel inspection
system in mass transportation centers has increased in recent
years. Extensive description of traditional and holographic
methods is provided in U.S. patent 5,455,590, hereby
incorporated by reference.

25 The holographic linear array of sequentially-switched
millimeter-wave transmitter-receivers scanned quickly over a
large aperture to actively illuminate the target as described
in U.S. Patent 5,455,590 uses a single frequency that is
coherent, which means the phase of the returned signal is
30 recorded as well as the amplitude. The holographic linear
array described in U.S. Pat. Application 08/440,279 improves
image quality by using a wideband system.

U.S. patent 5,170,170 to Soumekh show a two-dimensional
reconstruction process. In his book entitled FOURIER ARRAY
35 IMAGING, Englewood Cliffs, New Jersey, Prentice Hall, 1994,
Soumekh derived a reconstruction process for a circular
aperture resulting in a two-dimensional image.

However, the previous systems lack the capability of
scanning an individual from all sides quickly without
40 inconveniencing the individual. Specifically, to fully
inspect a person for concealed objects, it is necessary to

- 2 -

image the person from many viewing angles. With a planar aperture, a person is required to pose at a number of predetermined positions while images are acquired. To obtain a sufficient number of images (8-128), total imaging time may
5 be as high as several minutes, which is unacceptable for high throughput applications including airports.

Thus, there is a need for a three-dimensional holographic imaging method and apparatus that can provide high resolution with fast scanning and fast image reconstruction.

10

SUMMARY OF THE INVENTION

The present invention disclosed herein involves a method and apparatus for achieving near real-time holographic imaging
15 of concealed objects. A vertical linear antenna array is actuated over a circular path to obtain a 360° cylindrical scan of a covered target, for example a clothed individual. The data are in the form of unfocused or diverging millimeter wave illumination which is capable of penetrating a cover, for
20 example clothing. The millimeter wave illumination must be mathematically focused or reconstructed into recognizable images. A completely new reconstruction algorithm is required to accept the wideband data gathered over a section of the 360° cylindrical aperture and form a fully focused three-
25 dimensional image. Subsets of the 360° data may be used to form images of the target from any cylindrical viewing position or viewing angle. Complete inspection of the target is accomplished by a single scan of the vertical linear antenna array about the circumference of the cylinder in
30 several seconds. Computer generated animation permits sequential viewing of images incremented by viewing angle. When the increments are small enough, the image will appear that the target is rotating slowly. An operator is then able to fully visually inspect the target for concealed objects.

35 The present invention is an extension of the holographic imaging system from planar imaging operation viewing a single side to cylindrical imaging operation viewing multiple sides. Rather than forming an image of one side, for example a front

- 3 -

view, the invention forms images from multiple sides. Wideband data are gathered over a two-dimensional cylindrical aperture. The use of a cylindrical aperture overcomes the single viewing angle limitation present in a planar aperture system. In this specification, the term wideband refers to integrated sending and receiving of at least two frequencies, as opposed to separate sending and receiving of at least two frequencies.

The wideband or broadband parameters with respect to number of frequencies, and range of frequencies are described in the U.S. patent application 08/440,279 hereby incorporated by reference. Moreover, U.S. 08/440,279 describes the antenna array and bi-static, heterodyne, in-phase transceiver preferred for cylindrical imaging, as well as alternative transceivers useful for cylindrical imaging.

In this patent application, the cylindrical scanner and the reconstruction algorithms are described.

It is an object of the present invention to provide a cylindrical wideband millimeter-wave imaging method and apparatus.

It is a further object of the present invention that the method and apparatus have an expanded depth of field and providing views or images from multiple viewing angles or multiple sides to accomplish near real-time imaging that is needed for personnel surveillance.

The subject matter of the present invention is particularly pointed out and distinctly claimed in the concluding portion of this specification. However, both the organization and method of operation, together with further advantages and objects thereof, may best be understood by reference to the following description taken in connection with accompanying drawings wherein like reference characters refer to like elements.

BRIEF DESCRIPTION OF THE DRAWINGS

FIG. 1 is a block diagram of a cylindrical wideband holographic system.

- 4 -

FIG. 2 is a conceptual diagram of a cylindrical wideband holographic system.

FIG. 3 is a schematic of a preferred bistatic, heterodyne, in-phase transceiver.

5 FIG. 3a is a schematic of a bistatic, heterodyne, quadrature receiver.

FIG. 4 is a coordinate definition diagram.

FIG. 5 is a diagram quantifying resolution.

10 FIG. 6 is an obverse image of a mannequin made with a planar scan.

FIG. 7 is an obverse image of a mannequin made with a cylindrical scan.

FIG. 8 is a reverse image of a mannequin made with a planar scan.

15 FIG. 9 is a reverse image of a mannequin made with a cylindrical scan.

FIG. 10 is an obverse image of a person made with an optical camera.

20 FIG. 11 is an obverse image of a person made with a cylindrical scan.

FIG. 12 is a series of images illustrating the computer animation.

DETAILED DESCRIPTION OF THE INVENTION

25

The following description begins with a description of a wideband cylindrical holographic imaging system followed by a derivation of a wideband cylindrical reconstruction algorithm. Operational Examples are then provided.

30

WIDEBAND CYLINDRICAL HOLOGRAPHIC SYSTEM

The wideband cylindrical holographic system (FIG. 1) is made up of an antenna array 10, transceiver 12, scanner 13, A/D converter 14, computer 16, and display 18. A system diagram (FIG. 2) shows a person 40 on a platform 41 within a scanner frame 42. The antenna array 10 is rotated about the person 40 to obtain the image(s).

35

- 5 -

The person 40 to be scanned is directed to stand relatively still on the platform 41 of the scanner frame 42 while vertical linear antenna array 10 around the person 40 in a cylindrical manner. Millimeter-wave illumination from the antenna array 10 passes through clothing and is reflected from concealed objects. The reflected millimeter-wave signals are recorded by the imaging system and focused, or reconstructed, using a computer 16 into recognizable images of the subject revealing concealed objects.

10

CYLINDRICAL SCANNER

The cylindrical scanner's 43 function is simply to rotate the vertical antenna array(s) 10 about the target being scanned. For a person as a target, this requires a scanner approximately 2 meters in height. The radius of the scan should be in the range of 0.75 meters - 1.25 meters. The radius must be large enough that a person can easily enter and exit the system and should be as small as possible to minimize the footprint, or floorspace, required of the scanner.

20

LINEAR ANTENNA ARRAY

The antenna array 10 spans the vertical length of the aperture, typically about 2 meters for personnel surveillance. The millimeter-wave source is switched to each antenna element in the array. The array can be configured to transmit and receive from the same antenna element, however, a preferred configuration uses separate transmit and receive arrays. Logic circuitry sequences the transmit and receive antennas to transmit from one antenna and receive the reflected wideband signal from each of the two neighboring antennas in the receive row. This places a virtual sampling point half-way between each transmit and receive antenna. The transmit row and receive row are preferably offset by half the antenna spacing, so the effective sample spacing is one-half of the single-row antenna spacing. This sequencing scheme cannot be used on the last antenna element, so the effective number of

30
35

- 6 -

sample points is reduced by one. The sampling density needed for the arrays is determined by the millimeter-wave center-frequency and by the Nyquist sampling criterion. Generally, sampling on the order of one-half wavelength is
5 optimal, with two-thirds wavelength providing acceptable results. For a 2 meter vertical array operating at 27 - 33 GHz, this would indicate that 300 - 400 antenna elements will be needed.

10 For a wideband system, the antenna array 10 may be a single transmit/receive antenna element that is moved across a two-dimensional aperture. It is preferred, that the antenna
15 10 be an array of antenna elements that is at least a single row of a plurality of antenna elements. Alternatively, antenna elements may be arranged so that one row is a set of transmit antenna elements and a second row is a set of receive
20 antenna elements. Separate transmit and receive antenna elements are preferred for a wideband system to avoid the need of a multi-frequency circulator.

20

TRANSCEIVER SWITCHES

Millimeter-wave switching is required in the cylindrical wideband holographic imaging system in order to provide
25 high-speed sampling of the cylindrical aperture. Under high-speed electronic control, a single transmit antenna and a single receive antenna must be individually connected to the transceiver. It is possible to construct an array using commercially available single pole double throw (SPDT)
30 pin-diode millimeter-wave waveguide switches, however, this array would be very bulky, and it would be difficult to arrange the outputs to have the desired spacing. To overcome this difficulty, a custom switch module, such as the single-pole 8-throw (SP8T) switch described in 08/440,279
35 hereby incorporated by reference, is desirable. Internally, the SP8T switch module uses a binary tree structure composed of three layers of SPDT switch elements for a total of 7 SPDT elements. Each SPDT element contains a duroid fin-line

- 7 -

printed circuit junction which uses shunt pin-diodes to direct the millimeter-wave signal to the desired output waveguide. The pin-diodes are controlled by electronic driver circuitry mounted in a housing on top of a split-block (not shown). One
5 of these SP8T modules may be connected to 8 other SP8T modules to form a 64 element switch sub-array. Several of these switch sub-arrays can then be connected to the vertical linear antenna array 10 with the required number of antenna elements.

10

ANTENNA ELEMENTS

The type of antenna element may be any type including but not limited to slot line, patch, endfire, waveguide, dipole, or any combination thereof. A preferred antenna element is a
15 polyrod antenna element as described in 08/440,279 hereby further incorporated by reference.

TRANSCEIVER

20 For the cylindrical system, a bi-static heterodyne, in-phase only transceiver (FIG. 3) is preferred. In this transceiver, the RF VCO wideband signal is transmitted directly by the transmit antenna 50. The received signal is received by the receiver 51 mixed in a mixer 52 and amplified
25 (amplifier 53 to down-convert the received signal to the intermediate frequency (IF). The LO VCO oscillator 54 is offset in frequency from the RF VCO oscillator 55 by the IF frequency. To maintain coherence, an IF REF signal is obtained by mixing the RF VCO and LO VCO signals with a second
30 mixer 56. This mixed signal is amplified and filtered in the amplifier 57 to remove higher frequency mixing products. Mixing the IF and IF REF signals in the final mixer 58 and amplifying in the final amplifier 59 yields the in-phase signal (I). Alternative transceivers may be used including
35 but not limited to those in 08/440, 279. More preferred is bi-static heterodyne in-phase and quadrature transceiver (FIG. 3a) because the in-phase only transceiver requires data from the entire scanned volume whereas using the in-phase and

- 8 -

quadrature transceiver permits shifting the origin or reference position to the center of the scan thereby permitting digitizing of data in a reduced volume surrounding the target.

5

A-D CONVERTER

The wideband data is sampled vertically along the array and angularly over the 360° aperture and is digitized by an Analog to Digital converter (A/D) for subsequent storage in the computer.

10

COMPUTER AND DISPLAY

After digitizing, the reconstruction algorithm discussed below is applied to a segment of the 360° data to reconstruct a three-dimensional image of the target from a single viewing angle. The three-dimensional image is then collapsed into a fully-focused two-dimensional image of the target for display on the computer. A number of these viewing angles can then be integrated into a single computer animation showing a smooth rotation of the image of the target under surveillance.

20

OTHER COMPONENTS

25

The VCO DRIVERS board, ARRAY-CPU INTERFACE board, Analog to Digital converter (A/D) and other detailed components are set forth in 08/440,279 hereby further incorporated by reference.

30

DERIVATION OF IMAGE RECONSTRUCTION ALGORITHM

The measurement configuration is shown in FIG. 4, where the primed coordinates represent the transceiver position 1, and the unprimed coordinates represent a single target point 2 in the target or image space 3. If the target 3 is characterized by a reflectivity function, $f(x,y,z)$, then the response measured at the transceiver position 1 will be the

35

superposition of the reflectivity function times the round trip phase to the target 4. The round-trip phase is

$$2k\sqrt{(R\cos\theta-x)^2 + (R\sin\theta-y)^2 + (z-z')^2} \quad (1)$$

5

The response measured at the transceiver position (1) is

$$s(\theta, \omega, z) = \iiint f(x, y, z) e^{j2k\sqrt{(R\cos\theta-x)^2 + (R\sin\theta-y)^2 + (z-z')^2}} dx dy dz \quad (2)$$

10 where $k = \omega/c$ is the wavenumber, and the amplitude decay with range is not considered since it will have little impact on focusing the image. If needed, amplitude decay with range may be compensated for in the raw data by applying a numerical gain to the data from the transceiver. The numerical gain increases with range.

15 Alternatively, the data could be collected in the time domain, as is common with acoustic data. In this case, the data in Equation 2 will be obtained by Fourier Transforming the gathered data, which is the echoed data in the time domain.

20 The exponential term in Equation 2 represents a spherical wave which is decomposed into plane wave components,

$$e^{j2k\sqrt{(R\cos\theta-x)^2 + (R\sin\theta-y)^2 + (z-z')^2}} = \iint e^{j2k_x \cos\phi (R\cos\theta-x) + j2k_x \sin\phi (R\sin\theta-y) + jk_z (z-z')} d\phi dk_z \quad (3)$$

25 This decomposition indicates that the spherical wave can be decomposed into equal amplitude and phase plane wave components emanating from the target point at (x, y, z) . The angle of each plane wave component in the x-y plane is ϕ which has limits of $\pm \pi/2$. For propagating plane waves, the
 30 limits of the z-component of the wavenumber will be $k_z \in [-$

2k, 2k]. The dispersion relation for the plane wave components is

$$k_x^2 + k_y^2 + k_z^2 = (2k)^2 \tag{4}$$

5

or defining k_r to be the wavenumber component in the x-y plane

$$k_r = \sqrt{k_x^2 + k_y^2} = \sqrt{4k^2 - k_z^2} \tag{5}$$

Using the plane-wave decomposition (5) in (2) the measured data can be expressed as

10

$$s(\theta, \omega, z) = \iint e^{j2k_r R \cos(\theta - \phi)} \left\{ \iiint f(x, y, z) e^{-j2(k_r \cos \phi)x - j2(k_r \sin \phi)y - jk_z z} dx dy dz \right\} e^{jk_z z'} d\phi dk_z \tag{6}$$

The term inside the { } represents a three-dimensional Fourier Transform of the target reflectivity sampled on a non-uniform grid. Defining a three dimensional Fourier Transform pair as

15

$$f(x, y, z) \leftrightarrow F(2k_r \cos \phi, 2k_r \sin \phi, k_z) \tag{7}$$

Yields,

20

$$s(\theta, \omega, z) = \iint e^{j2k_r R \cos(\theta - \phi)} F(2k_r \cos \phi, 2k_r \sin \phi, k_z) e^{jk_z z'} d\phi dk_z \tag{8}$$

The integral over k_z is an inverse Fourier Transform, so taking the Fourier Transform with respect to z of both sides and dropping the distinction between z and z' yields

25

- 11 -

$$S(\theta, \omega, k_z) = \int_{-\pi/2}^{\pi/2} e^{j2k_r R \cos(\theta-\phi)} F(2k_r \cos \phi, 2k_r \sin \phi, k_z) d\phi \quad (9)$$

Defining

$$F_p(\phi, 2k_r, k_z) \equiv F(2k_r \cos \phi, 2k_r \sin \phi, k_z) \quad (10)$$

$$g(\theta, k_r) \equiv e^{j2k_r R \cos \theta} \quad (11)$$

5

yields

$$S(\theta, \omega, k_z) = \int_{-\pi/2}^{\pi/2} g(\theta-\phi, k_r) F_p(\phi, 2k_r, k_z) d\phi \quad (12)$$

10

which represents a convolution in the θ domain

$$S(\theta, \omega, k_z) = g(\theta-\phi, k_r) * F_p(\phi, 2k_r, k_z) \quad (13)$$

15 Taking the Fourier Transform with respect to θ and denoting the Fourier domain for θ by ξ , the convolution becomes a multiplication

$$S(\xi, \omega, k_z) = \tilde{F}_p(\xi, 2k_r, k_z) G(\xi, k_r) \quad (14)$$

20

or

$$\tilde{F}_p(\xi, 2k_r, k_z) = \frac{S(\xi, \omega, k_z)}{G(\xi, k_r)} \quad (15)$$

- 12 -

Denoting Fourier Transformation or its inverse using a script \mathcal{F} yields

$$F(2k_r \cos\theta, 2k_r \sin\theta, k_z) = \mathcal{F}_{(\xi)}^{-1} \left[\frac{S(\xi, \omega, k_z)}{G(\xi, k_r)} \right] \quad (16)$$

The term in the denominator of (16) can be computed

5 numerically by performing the Fourier Transform using the FFT on an angularly sampled version of (11), or it may be determined analytically for $\xi \ll 2k_r R$ using a definition of the Hankel function of the first kind ξ order and its asymptotic form

10

$$G(\xi, 2k_r) = H_{\xi}(2k_r R) e^{j\pi\xi/2} \approx e^{j\sqrt{4k_r^2 R^2 - \xi^2}} \quad (17)$$

This yields the simplest form of the inversion

$$F(2k_r \cos\theta, 2k_r \sin\theta, k_z) = \mathcal{F}_{(\xi)}^{-1} \left[S(\xi, \omega, k_z) e^{-j\sqrt{4k_r^2 R^2 - \xi^2}} \right] \quad (18)$$

where $2k_r \cos\theta = k_x$ and $2k_r \sin\theta = k_y$

15

in the spatial frequency domain. The data will be non-uniformly sampled in the spatial frequency domain and will therefore need to be interpolated onto a uniform (k_x, k_y, k_z) grid prior to computation of the final three-dimensional inverse

20 Fourier Transform that yields the reconstructed image in rectangular coordinates

$$f(x, y, z) = \mathcal{F}_{(k_x, k_y, k_z)}^{-1} \left[\mathcal{F}_{(\xi)}^{-1} \left[S(\xi, \omega, k_z) e^{-j\sqrt{4k_r^2 R^2 - \xi^2}} \right] \right] \quad (19)$$

The discussion above shows how the gathered data can be
25 inverted to obtain the target's reflectivity function or image. The steps that must be performed to reconstruct this image are summarized below.

Image Reconstruction Algorithm

The steps required to implement the reconstruction technique on a computer are outlined below. The data is discretized in (θ, ω, z) and the image is discretized in (x, y, z) . Fourier Transforms will typically be done using the discrete Fast Fourier Transform algorithm.

Reconstruction Algorithm

1. Gather sampled data, $s(\theta, \omega, z)$, from the transceiver over a cylindrical aperture. If the sampled data is available with only one or the other of the real component (I) or the imaginary component (Q), the remaining component may be derived from the sampled data using the Hilbert Transform as discussed in D. Slater NEAR FIELD ANTENNA MEASUREMENTS, Artech House, Boston, MA, 1991.

2. Perform 2-D FFT of this data with respect to θ and z to obtain $S(\xi, \omega, k_z)$.

3. Multiply by a phase-factor and perform 1-D inverse FFT to obtain

$$\mathcal{F}_{(\xi)}^{-1} \left[S(\xi, \omega, k_z) e^{-j\sqrt{4k_r^2 R^2 - \xi^2}} \right] \tag{20}$$

4. Interpolate this data onto uniformly sampled (k_x, k_y, k_z) grid from the uniformly sampled (θ, ω, k_z) data.

$$F(k_x, k_y, k_z) = \mathcal{F}_{(\xi)}^{-1} \left[S(\xi, \omega, k_z) e^{-j\sqrt{4k_r^2 R^2 - \xi^2}} \right] \begin{cases} \theta = \tan^{-1}(k_y / k_x) \\ \omega = \frac{c}{2} \sqrt{k_x^2 + k_y^2 + k_z^2} \\ k_r = \sqrt{k_x^2 + k_y^2} \end{cases} \tag{21}$$

- 14 -

5. Perform the 3-D inverse FFT.

$$f(x, y, z) = \mathcal{F}_{(k_x, k_y, k_z)}^{-1} [F(k_x, k_y, k_z)] \quad (22)$$

6. Compute the magnitude of the image data.

5

7. Render/display the image(s).

This image reconstruction technique relies on formation of the image in the spatial frequency domain. The resolution
 10 obtained in the image can be determined by examining the extent or width of the coverage in the spatial frequency domain. For the cylindrical image reconstruction, the spatial frequency coverage is of a polar region shown in FIG. 5. Approximating the polar region as rectangular results in a
 15 horizontal cross range resolution of

$$\delta_x = \frac{\lambda_c}{4 \sin(\theta_{arc}/2)} \quad (23)$$

where λ_c is the wavelength at the center frequency.

The vertical resolution will be determined by θ_b , the lesser of
 20 the antenna full beamwidth or the angle subtended by the aperture in the z direction. The width of the spatial frequency coverage in the z direction is approximately $4k_c \sin(\theta_b/2)$. This results in a vertical cross-range resolution of

$$\delta_z = \frac{\lambda_c}{4 \sin(\theta_b/2)} \quad (24)$$

25

The spatial frequency width in the k_y direction is $2(k_2 - k_1)$ where k_1 and k_2 are the wavenumbers at the low and high frequencies of the system. This width results in a range
 30 resolution of approximately

- 15 -

$$\delta_y = \frac{2\pi}{2(k_2 - k_1)} = \frac{c}{2B} \quad (25)$$

where c is the speed of light and B is the temporal frequency bandwidth of the system.

5

COMPUTER INSTRUCTIONS

The steps of the reconstruction algorithm reside on the digital computer as

- (i) a first set of instructions for receiving
10 data from the A/D converter,
- (ii) a second set of instructions for computing a two-dimensional Fourier transform of the received data for each frequency,
- (iii) a third set of instructions for
15 multiplying the two-dimensional Fourier transform by a phase factor and computing a one-dimensional inverse Fourier transform,
- (iv) a fourth set of instructions for interpolating the one-dimensional inverse Fourier transform
20 onto a uniformly sampled grid and forming an interpolated product,
- (v) a fifth set of instructions for computing a three-dimensional inverse transform of the interpolated product and obtaining a complex cylindrical three-dimensional
25 image,
- (vi) a sixth set of instructions for computing a magnitude of the complex cylindrical three-dimensional image and obtaining a cylindrical three-dimensional image, and
- (vii) a seventh set of instructions for
30 displaying the cylindrical three-dimensional image.

IMAGING

Reconstructing a large number of frames, 8-128, preferably
35 32-128 frames, permits smooth transitions between images, making the results suitable for computer animation at a rate

- 16 -

from about 4 to 32 frames per second. It is further preferred that the frames are obtained from overlapping arc segments of data to improve smooth transitions. By observing a full animation, the subject is viewed from all angles without
5 requiring inspector examination of separate still images.

The actual data processing of the above described seven steps produces a single image from a single viewing angle or arc segment of the 360° data. Overlapping arc segments permits viewing around corners, within depressions or other
10 topographical perturbations of the target. For example, for imaging a clothed person, an imaging sequence may use 90° arc segments overlapped in 10° increments, or 0-90°, 10-100°, . . . , 350-80°, to form 36 images with illuminations centered at 10° increments. Each frame or arc segment reconstruction is
15 computationally intensive. Therefore, high-speed image reconstruction is preferably achieved with high-speed parallel computer processors. To overcome difficulties of shared access to the data that is overlapped by a plurality of parallel computer processors, it is preferred that each arc
20 segment reconstruction is accomplished by a single processor module. Each processor module receives its arc segment data from a digital multiplexer. Use of the multiplexer permits presenting data that is identical in an overlap to several of the processor modules simultaneously, permitting highly
25 efficient video image reconstruction. Although efficient and fast because each processor module operates independently, more computer memory is needed for redundancy of data storage. Use of the multiplexer further permits near real time reconstruction of the image data. Reconstruction of the first
30 arc segment may commence as soon as the first arc segment data are received. It is not necessary to wait until the scan has completed a full 360° rotation.

EXAMPLE 1

35 An experiment was performed to compare the image obtained with a planar aperture wideband holographic system to an image obtained with a cylindrical wideband holographic system according to the present invention.

- 17 -

The reconstruction algorithm was fully implemented on a Sun workstation in the C programming language. A first system utilized a single channel millimeter wave transceiver mounted on an x-y scanner in cooperation with a rotating platform.

5 The rotary platform was used to rotate the subject to be imaged by small angular increments between vertical scans. Although convenient, for laboratory imaging, the x-y scanner in cooperation with the rotating platform required up to 20 minutes to collect 360° of data.

10 The imaging target was a mannequin torso having a concealed object. FIGS. 6-9 show the dramatic improvement in image quality that has been obtained by using a cylindrical aperture instead of a planar aperture. The images from both planar and cylindrical systems were taken at between 90 to 100

15 GHz frequencies. The planar aperture images FIGS. 6 and 8 exhibited more shadows because the planar aperture width of 40 cm and depth of 60 cm corresponds to only 37° of angular coverage whereas the cylindrical aperture exhibited fewer shadows using 120° of 360° data FIGS. 7 and 9.

20

EXAMPLE 2

An experiment was conducted to demonstrate the system with a person with a concealed object. In this example, a 128 element 27-33 GHz linear array was used in a vertical position

25 in combination with a rotary platform. This system acquired 360° of data in less than several seconds, about 2.5 seconds.

FIG. 10 shows a photograph of a man with a concealed object and FIG. 11 shows the cylindrical image revealing the object, a Glock-17 handgun.

30

EXAMPLE 3

An experiment was conducted to demonstrate reconstruction of sequential overlapping data. FIG. 12 shows a mannequin with a small handgun taped to its back and covered with a cotton t-shirt, imaged over a 360° aperture. Eight of 64 view angles

35 are shown in FIG. 12. Computer animation of the 64 view angles resulted in smooth animation of the images at frame rates of 4-32 frames per second. By observing the full

- 18 -

animation, the target is viewed from all angles without
requiring separate examination of a plurality of still images.
The animation further preserves the three-dimensional nature
of the target with concealed objects appearing "off" the
5 target in several frames of the animation.

CLOSURE

While the forms of the invention herein disclosed
10 constitute presently preferred embodiments, many others are
possible. It is not intended herein to mention all of the
possible equivalent forms or ramifications of the invention.
It is to be understood that the terms used herein are merely
descriptive, rather than limiting, and that various changes
15 may be made without departing from the spirit or scope of the
invention.

- 19 -

We Claim:

1. A holographic apparatus for near real-time imaging of a target, said apparatus utilizing millimeter wave radiation having a plurality of frequencies from about 1 to about 110 GHz, comprising:
 - (a) a holographic array having a plurality of antenna units spaced apart from about 0.25 to about 3 wavelength, wherein each unit sends and/or receives millimeter wave radiation, said array spaced apart from said target;
 - (b) a holographic wideband transceiver for operating said antenna units and providing each unit with millimeter wave radiation source, then receiving high frequency millimeter wave radiation reflection from said target and collected by the unit, then making an output;
 - (c) an analog to digital converter for converting said output to a corresponding digital signal; and
 - (d) a computer for applying a three dimensional reconstruction algorithm to the corresponding digital signal that preserves an unlimited depth of field, wherein the improvement comprises:
 - said computer is a digital computer having,
 - (i) a first set of instructions for receiving data from the A/D converter,
 - (ii) a second set of instructions for computing a two-dimensional Fourier transform of the received data for each frequency,
 - (iii) a third set of instructions for multiplying the two-dimensional Fourier transform by a phase factor and computing a one-dimensional inverse Fourier transform,
 - (iv) a fourth set of instructions for interpolating the one-dimensional inverse Fourier transform onto a uniformly sampled grid and forming an interpolated product,
 - (v) a fifth set of instructions for computing a three-dimensional inverse transform of the interpolated

- 20 -

product and obtaining a complex cylindrical three-dimensional image,

(vi) a sixth set of instructions for computing a magnitude of the complex cylindrical three-dimensional image and obtaining a cylindrical three-dimensional image, and

(vii) a seventh set of instructions for displaying the cylindrical three-dimensional image.

2. The apparatus as recited in claim 1, wherein said antenna units are bistatic.

3. The apparatus as recited in claim 1, wherein said output is an in-phase output.

4. The apparatus as recited in claim 1, wherein the first set of instructions further comprises:

a subset of instructions for deriving complex data (Q) from in-phase data (I).

5. The apparatus as recited in claim 1, said array comprises:

a linear array, moved by a mechanical means during transmission and receipt of said high frequency millimeter wave radiation, thereby providing a simultaneous scan of source and reflection millimeter wave radiation.

6. The apparatus as recited in claim 1, wherein said transceiver is a bistatic, heterodyne, in-phase output transceiver.

7. A method of holographic surveillance of a target, comprising the steps of:

(a) scanning a cylindrical aperture with a holographic array having a plurality of antenna units spaced apart from about 0.25 to about 3 wavelength, wherein each unit sends and/or receives millimeter wave radiation, said array spaced apart from said target;

- 21 -

(b) operating individual antenna elements with a wideband holographic transceiver system and providing each unit with a wideband millimeter wave radiation source, then receiving wideband millimeter wave radiation reflection from said target and collected by the unit(s), then making an output;

(c) converting said output in an A/D converter to a corresponding digital signal; and

(d) applying a three dimensional reconstruction algorithm to the digital signal that preserves a low f-number by the steps of:

- (i) receiving data from the A/D converter,
- (ii) computing a two-dimensional Fourier transform of the received data for each frequency,
- (iii) multiplying the two-dimensional Fourier transform by a phase factor and performing a one-dimensional inverse Fourier transform and forming an inversion,
- (iv) interpolating the inversion onto a uniformly sampled grid and forming an interpolated product,
- (v) computing a three-dimensional inverse transform of the interpolated product and obtaining a complex three-dimensional image,
- (vi) computing a magnitude of the complex three-dimensional image and obtaining a cylindrical three-dimensional image, and
- (vii) displaying the three-dimensional image.

8. The method as recited in claim 7, wherein applying the three dimensional reconstruction algorithm includes applying a transform to derive an imaginary digital signal to reconstruct a holographic image.

9. The method as recited in claim 7, wherein receiving the data further comprises:

deriving complex data (Q) from in-phase data (I).

1/7

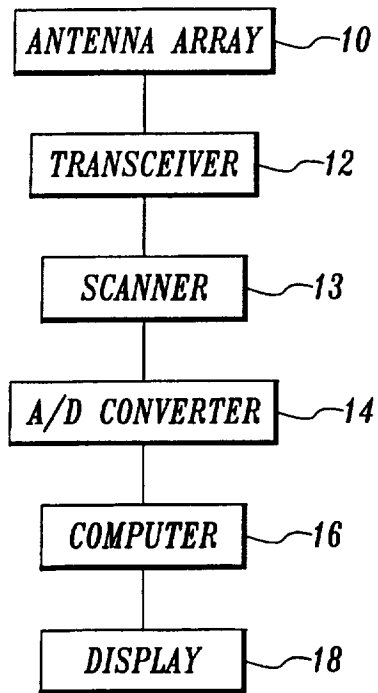

Fig. 1

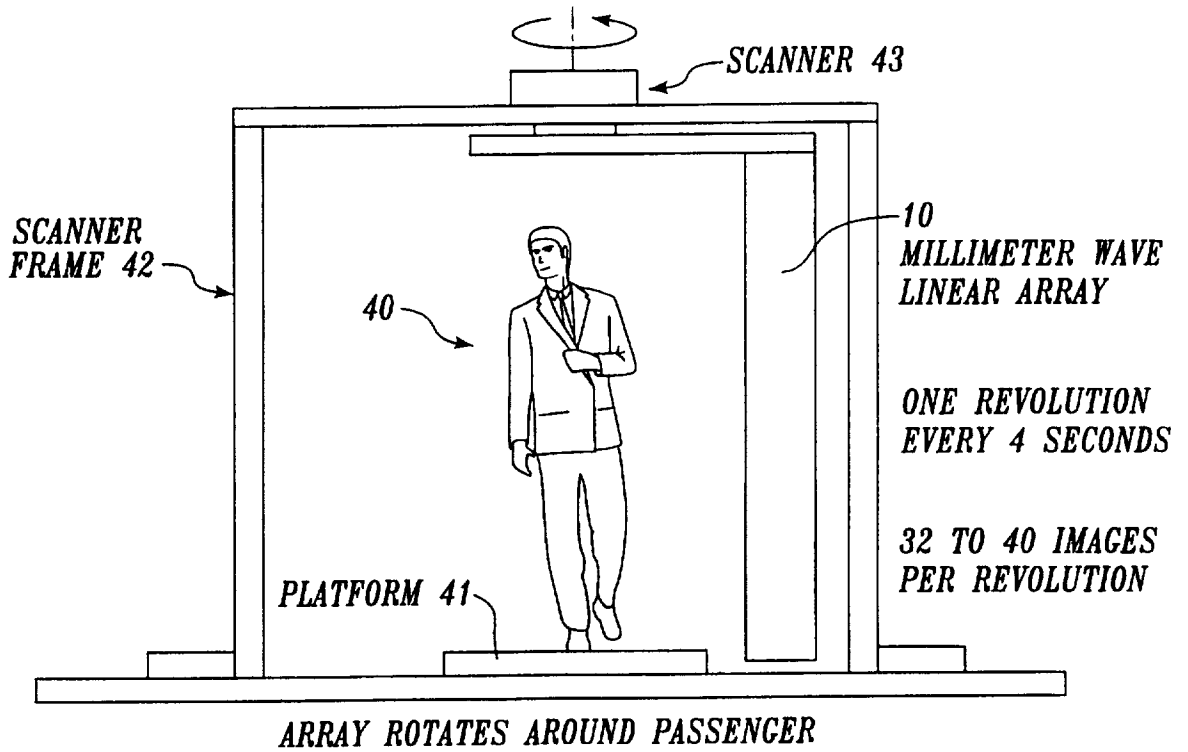

Fig. 2

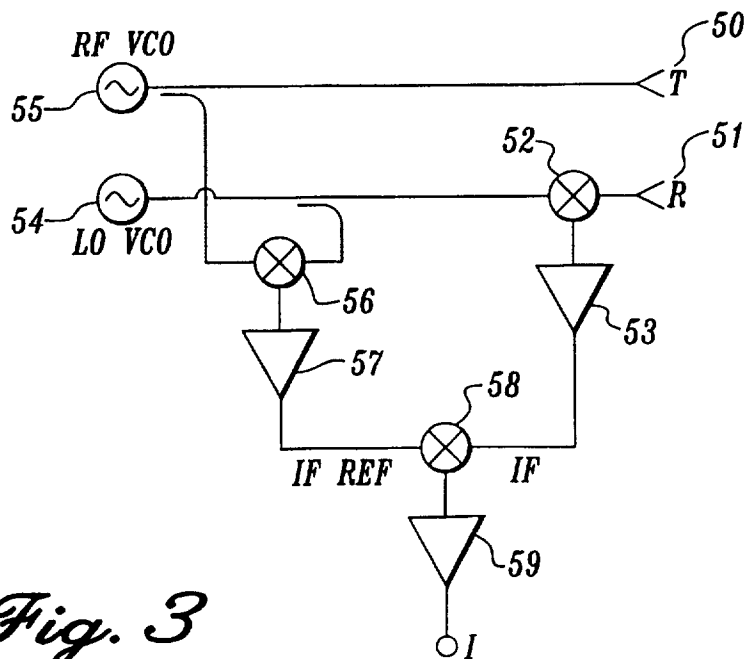

Fig. 3

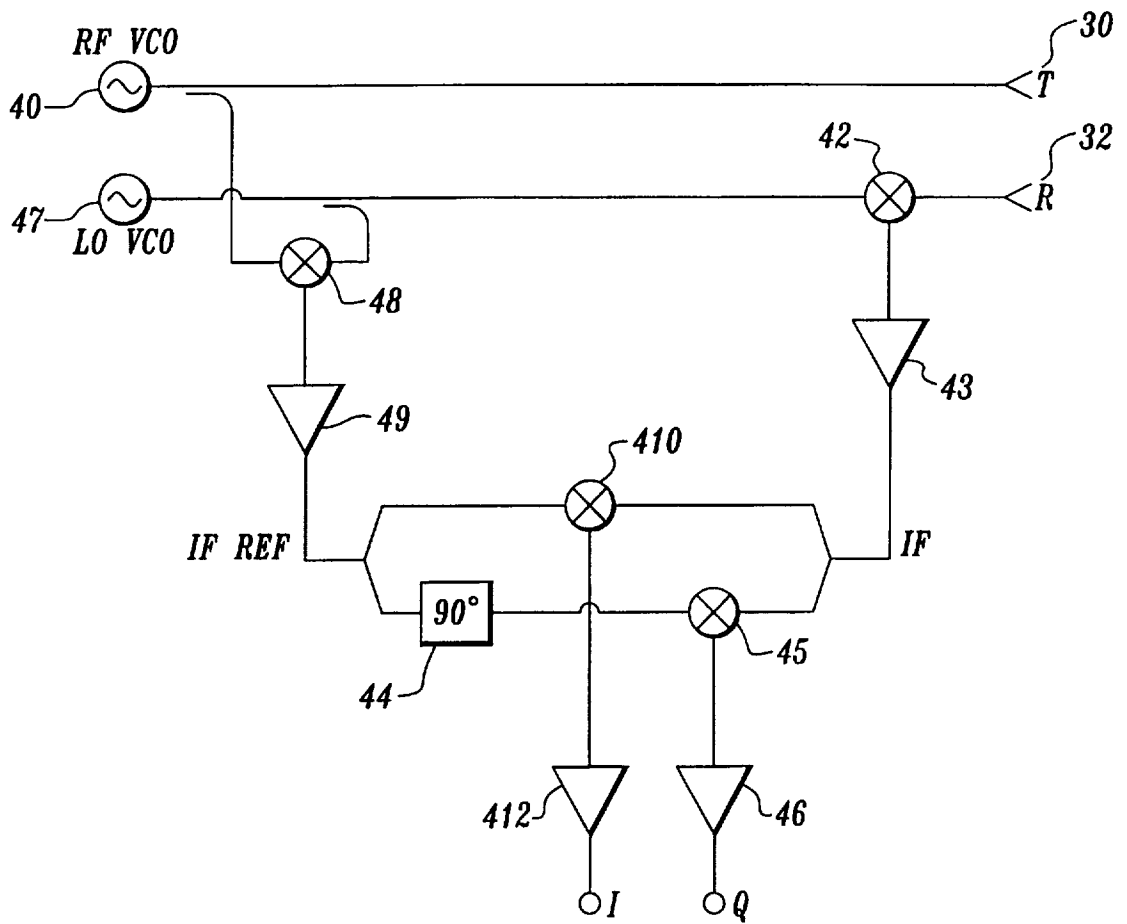

Fig. 3A

Fig. 4

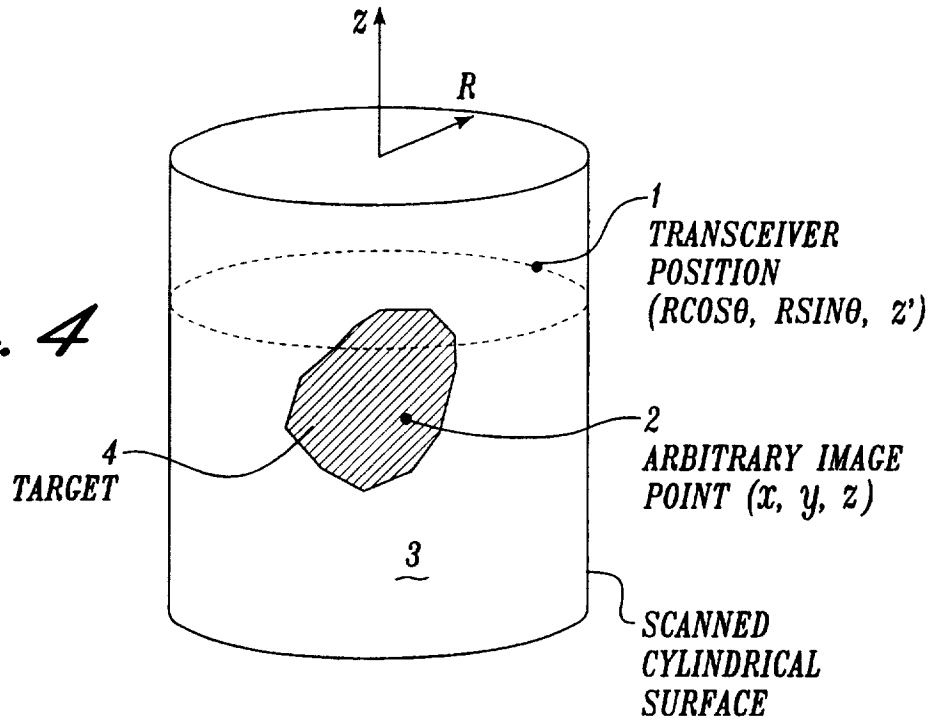
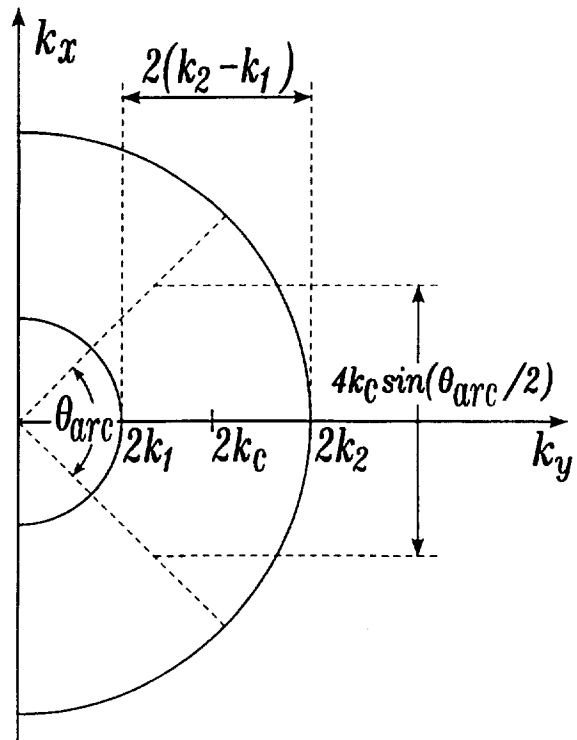

Fig. 5



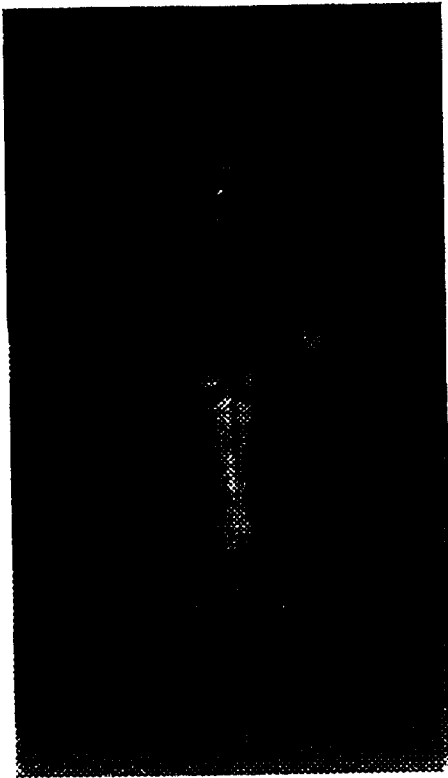

Fig. 6

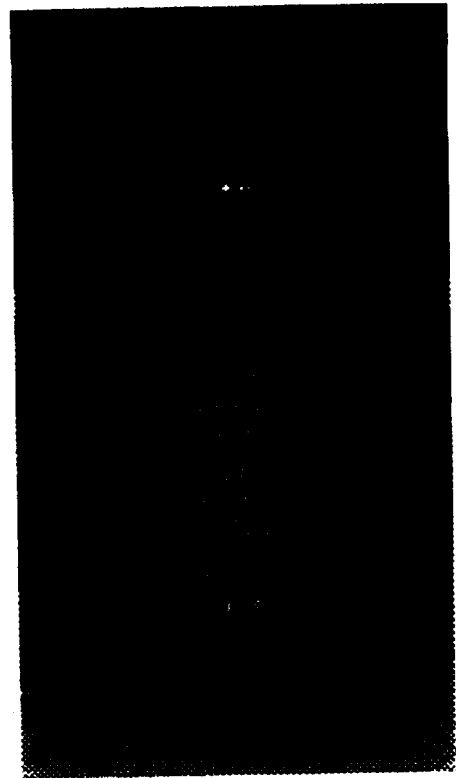

Fig. 7

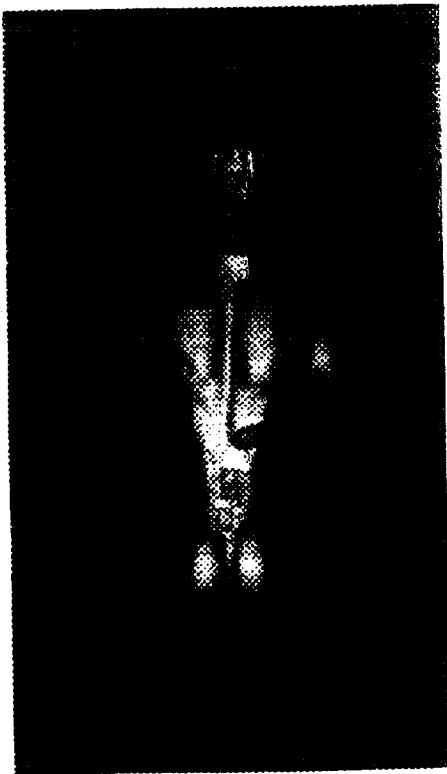

Fig. 8



Fig. 9



Fig. 10

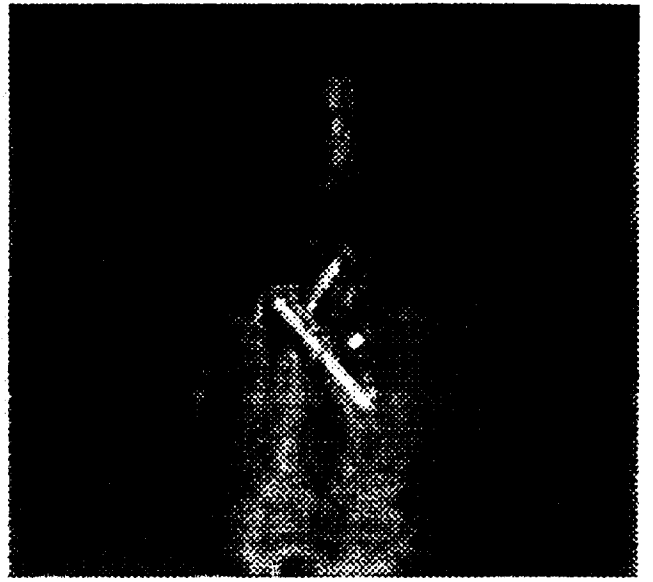

Fig. 11

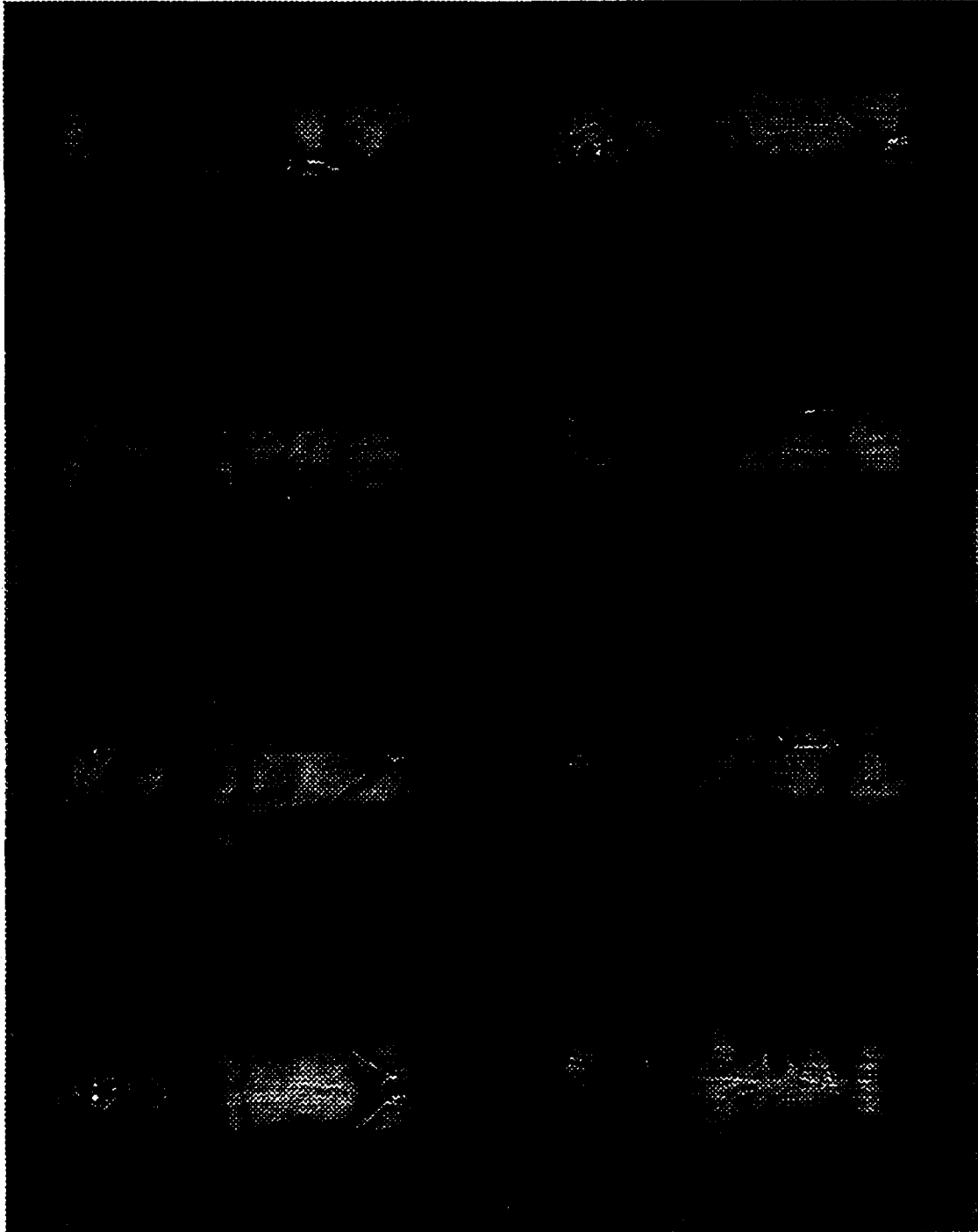

Fig. 12

INTERNATIONAL SEARCH REPORT

International Application No
PCT/US 97/15723

A. CLASSIFICATION OF SUBJECT MATTER
IPC 6 G01S13/89 G06T11/00 A61B5/05

According to International Patent Classification (IPC) or to both national classification and IPC

B. FIELDS SEARCHED

Minimum documentation searched (classification system followed by classification symbols)
IPC 6 G01S G06T A61B

Documentation searched other than minimum documentation to the extent that such documents are included in the fields searched

Electronic data base consulted during the international search (name of data base and, where practical, search terms used)

C. DOCUMENTS CONSIDERED TO BE RELEVANT

Category *	Citation of document, with indication, where appropriate, of the relevant passages	Relevant to claim No.
A	US 5 455 590 A (COLLINS H DALE ET AL) 3 October 1995 cited in the application see claims 1,9 ---	1,2,4-9
A	DE 44 13 689 C (SIEMENS AG) 8 June 1995 see claim 1 ---	1,7
A	US 4 991 093 A (ROBERGE WAYNE ET AL) 5 February 1991 see claim 3 ---	1,7
P,A	US 5 557 283 A (SHEEN DAVID M ET AL) 17 September 1996 cited in the application see claims 1-10 -----	1,2,4-9

Further documents are listed in the continuation of box C.

Patent family members are listed in annex.

* Special categories of cited documents :

- "A" document defining the general state of the art which is not considered to be of particular relevance
- "E" earlier document but published on or after the international filing date
- "L" document which may throw doubts on priority claim(s) or which is cited to establish the publication date of another citation or other special reason (as specified)
- "O" document referring to an oral disclosure, use, exhibition or other means
- "P" document published prior to the international filing date but later than the priority date claimed

- "T" later document published after the international filing date or priority date and not in conflict with the application but cited to understand the principle or theory underlying the invention
- "X" document of particular relevance; the claimed invention cannot be considered novel or cannot be considered to involve an inventive step when the document is taken alone
- "Y" document of particular relevance; the claimed invention cannot be considered to involve an inventive step when the document is combined with one or more other such documents, such combination being obvious to a person skilled in the art.
- "&" document member of the same patent family

Date of the actual completion of the international search

12 December 1997

Date of mailing of the international search report

30/12/1997

Name and mailing address of the ISA
European Patent Office, P.B. 5818 Patentlaan 2
NL - 2280 HV Rijswijk
Tel. (+31-70) 340-2040, Tx. 31 651 epo nl.
Fax: (+31-70) 340-3016

Authorized officer

Haffner, R

INTERNATIONAL SEARCH REPORT

Information on patent family members

International Application No

PCT/US 97/15723

Patent document cited in search report	Publication date	Patent family member(s)	Publication date
US 5455590 A	03-10-95	US 5557283 A AU 2012292 A MX 9204823 A WO 9305408 A	17-09-96 05-04-93 01-02-93 18-03-93
DE 4413689 C	08-06-95	JP 7294456 A US 5654995 A	10-11-95 05-08-97
US 4991093 A	05-02-91	CA 1262780 A EP 0216507 A JP 63220843 A	07-11-89 01-04-87 14-09-88
US 5557283 A	17-09-96	US 5455590 A AU 2012292 A MX 9204823 A WO 9305408 A	03-10-95 05-04-93 01-02-93 18-03-93