

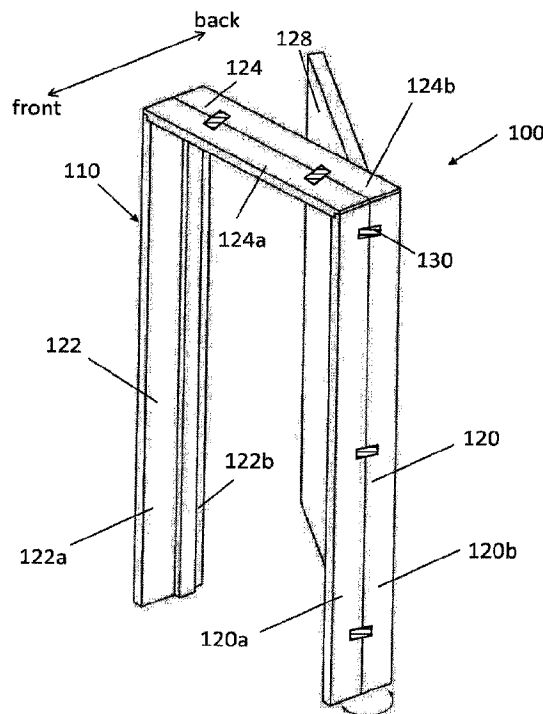

(86) **Date de dépôt PCT/PCT Filing Date:** 2017/03/10  
 (87) **Date publication PCT/PCT Publication Date:** 2017/09/14  
 (45) **Date de délivrance/Issue Date:** 2023/09/26  
 (85) **Entrée phase nationale/National Entry:** 2018/09/07  
 (86) **N° demande PCT/PCT Application No.:** US 2017/021841  
 (87) **N° publication PCT/PCT Publication No.:** 2017/156422  
 (30) **Priorités/Priorities:** 2016/03/11 (US62/307,148);  
 2016/11/03 (US62/417,029)

(51) **Cl.Int./Int.Cl. E06B 1/04** (2006.01),  
**E06B 1/30** (2006.01), **E06B 1/52** (2006.01)  
 (72) **Inventeurs/Inventors:**  
 EGE, PATRICK C., US;  
 VAZQUEZ, ROLDAN, US  
 (73) **Propriétaire/Owner:**  
 MASONITE CORPORATION, US  
 (74) **Agent:** SMART & BIGGAR LP

(54) **Titre : DISPOSITIFS ET PROCEDES DE MONTAGE DE CADRES DE PORTE**  
 (54) **Title: DEVICES AND METHODS FOR MOUNTING DOOR FRAMES**



(57) **Abrégé/Abstract:**

The present invention relates to a door frame, particularly a door frame for a pre-hung door assembly, which is foldable to minimize storage space and to allow for enhanced logistic efficiencies. The door frame contains parallel, spaced apart, vertical jambs and a horizontal header connecting the top ends of the jambs. Each of the jambs and the horizontal header contains a front section and back section that are hingedly joined so that they can be folded on to each other. The hingedly joined front and back sections allow the door frame to be foldable to minimize space occupied during storage.

(12) INTERNATIONAL APPLICATION PUBLISHED UNDER THE PATENT COOPERATION TREATY (PCT)

(19) World Intellectual Property  
Organization  
International Bureau(10) International Publication Number  
**WO 2017/156422 A1**(43) International Publication Date  
14 September 2017 (14.09.2017)

## (51) International Patent Classification:

E06B 1/04 (2006.01) E06B 1/52 (2006.01)  
E06B 1/30 (2006.01)

## (21) International Application Number:

PCT/US2017/021841

## (22) International Filing Date:

10 March 2017 (10.03.2017)

## (25) Filing Language:

English

## (26) Publication Language:

English

## (30) Priority Data:

62/307,148 11 March 2016 (11.03.2016) US  
62/417,029 3 November 2016 (03.11.2016) US

(71) Applicant: **MASONITE CORPORATION** [US/US];  
One Tampa City Center, 201 N. Franklin Street, Suite 300,  
Tampa, Florida 33602 (US).

(72) Inventors: **EGE, Patrick C.**; 29 White Birch Lane, West-  
mont, Illinois 60559 (US). **VAZQUEZ, Roldan**; 3401  
Greenwood Lane, St. Charles, Illinois 60175 (US).

(74) Agent: **BERENATO, III, Joseph W.**; Berenato & White,  
LLC, 6550 Rock Spring Drive, Suite 240, Bethesda, Mary-  
land 20817 (US).

(81) Designated States (unless otherwise indicated, for every kind of national protection available): AE, AG, AL, AM, AO, AT, AU, AZ, BA, BB, BG, BH, BN, BR, BW, BY, BZ, CA, CH, CL, CN, CO, CR, CU, CZ, DE, DJ, DK, DM, DO, DZ, EC, EE, EG, ES, FI, GB, GD, GE, GH, GM, GT, HN, HR, HU, ID, IL, IN, IR, IS, JP, KE, KG, KH, KN, KP, KR, KW, KZ, LA, LC, LK, LR, LS, LU, LY, MA, MD, ME, MG, MK, MN, MW, MX, MY, MZ, NA, NG, NI, NO, NZ, OM, PA, PE, PG, PH, PL, PT, QA, RO, RS, RU, RW, SA, SC, SD, SE, SG, SK, SL, SM, ST, SV, SY, TH, TJ, TM, TN, TR, TT, TZ, UA, UG, US, UZ, VC, VN, ZA, ZM, ZW.

(84) Designated States (unless otherwise indicated, for every kind of regional protection available): ARIPO (BW, GH, GM, KE, LR, LS, MW, MZ, NA, RW, SD, SL, ST, SZ, TZ, UG, ZM, ZW), Eurasian (AM, AZ, BY, KG, KZ, RU, TJ, TM), European (AL, AT, BE, BG, CH, CY, CZ, DE, DK, EE, ES, FI, FR, GB, GR, HR, HU, IE, IS, IT, LT, LU, LV, MC, MK, MT, NL, NO, PL, PT, RO, RS, SE, SI, SK, SM, TR), OAPI (BF, BJ, CF, CG, CI, CM, GA, GN, GQ, GW, KM, ML, MR, NE, SN, TD, TG).

## Published:

— with international search report (Art. 21(3))

## (54) Title: DEVICES AND METHODS FOR MOUNTING DOOR FRAMES

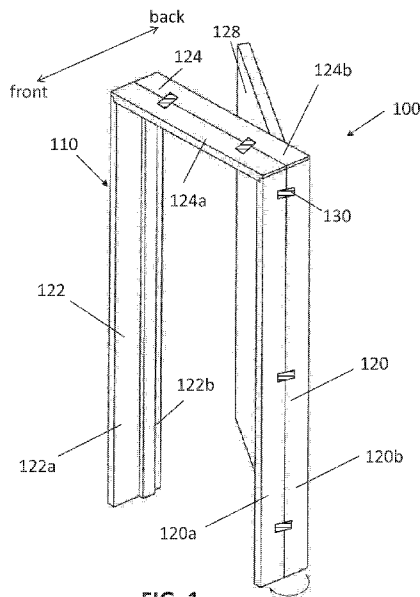

(57) Abstract: The present invention relates to a door frame, particularly a door frame for a pre-hung door assembly, which is foldable to minimize storage space and to allow for enhanced logistic efficiencies. The door frame contains parallel, spaced apart, vertical jambs and a horizontal header connecting the top ends of the jambs. Each of the jambs and the horizontal header contains a front section and back section that are hingedly joined so that then can be folded on to each other. The hingedly joined front and back sections allow the door frame to be foldable to minimize space occupied during storage.

## **DEVICES AND METHODS FOR MOUNTING DOOR FRAMES**

### **FIELD**

**[0001]** The present disclosure relates to door frames, particularly a door frame for a pre-hung door assembly, which is foldable to minimize storage space during shipping and to allow for enhanced logistic efficiencies.

### **BACKGROUND**

**[0002]** Many doors, either commercial or residential, are purchased as pre-hung door assemblies. A pre-hung door assembly is delivered for installation with the door already hingedly connected to the door frame that is to be inserted into the building opening where the door is to be located. Pre-hanging is accomplished by attaching the door to one side of the door frame, typically by one or more hinges. The other side of the door may be provided with a lockset and knob opening. The jamb member positioned immediately adjacent to the lockset and knob opening side is fitted with a latch or striker plate and associated opening so that the door can be securely shut after it has been installed. Pre-hanging is usually performed at the door-making facility, which typically is remote from where the door and its frame are to be installed. Once the door has been pre-hung it needs to be shipped, typically by truck, to the building location.

**[0003]** Doors, especially pre-hung door assemblies, are usually stored by placing one directly adjacent to another front-to-back. This method of storage maximizes space usage by eliminating spaces between adjacent door assemblies. It is, therefore, desirable to have a door frame with a small footprint so that wasted space is further eliminated for efficient storage and

enhanced logistic efficiencies. In other words, more doors and their frames can be shipped by truck if the footprint is reduced. Shipping can be expensive and thus costly, so minimizing that expense is important to reducing costs.

## **SUMMARY**

**[0004]** In one embodiment, there is provided a door frame, particularly a door frame of a pre-hung door assembly. The door frame is configured to be foldable to minimize space occupied during storage and shipment. The door frame contains parallel, spaced apart, vertical jambs and a horizontal header connecting the top ends of the jambs. Each of the jambs and the horizontal header contains a front section and back section that are hingedly joined so that the front section can be folded onto the back section or vice versa. In the folded position, the door frame has a reduced footprint and takes up less space than in the unfolded or installation orientation.

**[0005]** In another embodiment, there is provided a pre-hung door assembly. The assembly includes a foldable door frame with a door slab hingedly hung on one of the door jambs. The door jambs and/or horizontal header may contain a door stop on their inner surface to function as a stop preventing the door slab from swinging through the opening of the frame.

**[0006]** Further embodiments provide methods for making the door frame and pre-hung door assembly, and methods for installing the pre-hung door assembly.

**[0006a]** In one embodiment, there is provided a door frame, including: a hinge side jamb parallel to a lock side jamb and a horizontally extending header jamb, said hinge side and lock side jambs being spaced apart and vertically extending, said horizontal header jamb connected to top ends of the hinge side and lock side jambs, each of the jambs has a front section and an adjacent back section, a hinge joins said front and back sections so that said front sections and

said back sections are configured to be folded onto each other when oriented in a folded position, each of said hinge side jamb, said lock side jamb, and said header jamb includes a door stop, all of the door stops positioned on the associated back section, a channel configured in each of said hinge side jamb, said lock side jamb, and said header jamb between the back section and said door stop, each front section of said hinge side jamb, said lock side jamb, and said header jamb includes a protrusion, each protrusion configured to fit into the associated channel to interlock the front section to the associated back section when said front sections and said back sections are oriented in an opened position.

**[0006b]** In another embodiment, there is provided a method for installing a pre-hung door assembly. The method involves providing the pre-hung door assembly described above, unfolding the front and back sections of the jambs such that the protrusions fit into the channels to form an interlock and inserting and securing the unfolded pre-hung door assembly into a wall opening.

**[0006c]** In another embodiment, there is provided a method for installing a pre-hung door assembly, involving the steps of: a. providing a pre-hung door assembly including i. a frame containing a hinge side jamb, a lock side jamb, and a horizontal header jamb, the hinge side and lock side jambs disposed in spaced parallel relation and the header jamb connecting top ends of the hinge side and lock side jambs, wherein each of the jambs is made of a front section and an adjacent back section joined by a hinge configured to allow the front and back sections to be folded, and including ii. a door slab mounted to the hinge side jamb; b. unfolding the front and back sections of the jambs; and c. inserting and securing the unfolded pre-hung door assembly into a wall opening.

**[0006d]** In another embodiment, there is provided a method for installing a pre-hung door assembly, involving the steps of: a. providing a pre-hung door assembly including i. a frame having a hinge side jamb, a lock side jamb, and a horizontal header jamb, the hinge side and lock side jambs disposed in spaced parallel relation and the header jamb connecting top ends of the hinge side and lock side jambs, wherein each of the jambs is made of a front section and an adjacent back section joined by a hinge configured to allow the front and back sections to be folded, wherein each back section of each of the hinge side jamb, lock side jamb, and horizontal header has an attached or integral door stop, and ii. a door slab mounted to the hinge side jamb, wherein each front section and associated back section are secured together via an interlock mechanism; b. unfolding the front and back sections of the jambs; and c. inserting and securing the unfolded pre-hung door assembly into a wall opening.

**[0006e]** In another embodiment, there is provided a door frame, including: a hinge side jamb, a lock side jamb parallel to the hinge side jamb, and a header jamb, wherein said hinge side and lock side jambs being spaced apart and vertically extending, said horizontal header jamb connected to top ends of the hinge side and lock side jambs, each of the jambs has a front section and an adjacent back section, a hinge joins said front and back sections so that said front sections and said back sections are configured to be folded onto each other when oriented in a folded position, wherein each front section and associated back section are secured together via an interlock mechanism when oriented in an open position.

**[0006f]** In another embodiment, there is provided a pre-hung door assembly including the door frame described above and a door slab mounted to the hinge side jamb.

## **BRIEF DESCRIPTION OF THE DRAWINGS**

**[0007]** The accompanying drawings are incorporated in and constitute a part of the specification. The drawings, together with the general description given above and the detailed description of the exemplary embodiments and methods given below, serve to explain the teachings herein. In such drawings:

**[0008]** FIG. 1 is a perspective view of a door frame in an opened or installation orientation;

**[0009]** FIG. 2 is a perspective view of a door frame in a folded orientation;

**[0010]** FIG. 3 is a cross-sectional view of an exemplary embodiment of a hinge side door jamb;

**[0011]** FIG. 4 is a fragmentary cross-sectional view of a hinge side door jamb placed in an opening that is thicker than the jamb;

**[0012]** FIG. 5 is a fragmentary cross-sectional assembly drawing of a hinge side door jamb and its substitute back section; and

**[0013]** FIG. 6 is a perspective view of a living hinge.

## DETAILED DESCRIPTION

[0014] Reference will now be made in detail to exemplary embodiments. It should be noted, however, that the broader aspects of the teachings herein are not necessarily limited to the specific details, representative materials and methods, and illustrative examples shown and described in connection with the exemplary embodiments and methods. Like reference characters refer to like parts throughout the drawings.

[0015] Referring to FIG. 1, there is provided a pre-hung door assembly **100** and methods for mounting the pre-hung door assembly **100** in a wall opening of a building. The door opening is typically framed by building studs connected by an opening header at the top of the studs. The door opening is prepared for a selected door frame size, so that a door frame **110** of selected size can fit and be retained therein.

[0016] The pre-hung door assembly **100** typically contains the door frame **110** and a door slab **128** hung therein. The door frame **110** is typically formed by parallel, spaced apart, vertical jambs **120** (hinge side jamb), **122** (lock side jamb) and a horizontal header **124** connecting the top ends of the jambs **120**, **122**, typically with mechanical fasteners. The jambs **120**, **122** and horizontal header **124** are typically made of wood, such as pine, fir, with pine being preferred, although hardwoods may also be used; plastics; or composite materials. Preferably, the door jambs **120**, **122** are constructed as flat jambs rather than split jambs. Optionally, the door frame **110** may also include a sill installed at the foot of the frame **110** and connecting the lower ends of the jambs **120**, **122**.

[0017] A door slab **128** is provided with the door frame **110**, as shown in FIG. 1, to form the pre-hung door assembly **100**. The door slab **128** may be solid core or hollow core and constructed, e.g., as described in U.S. Patent Application Publication No. **2014/0261991**. The

door slab **128** may be hingedly attached to the hinge side jamb **120** by two or more door hinges. Two, three, four, five, or more door hinges may be used to attach the door slab **128** to the hinge side jamb **120**, depending on the size of the door. For a typical door used in a home, three hinges are typically used to mount the door slab **128** to the door frame **110**. The door hinges may be typical hinges, such as made from steel, used to mount doors to allow the door slab **128** to swing between a closed position and an opened position within the door frame **110**. As used herein and shown in FIG. 1 via the arrow, the side toward which the door slab **128** opens is referred to as the back side, while the opposing side is referred to as the front side. Preferably, the door jambs **120**, **122** and/or horizontal header **124**, each contains a door stop (best shown as **300** in FIG. 3) on its inner surface. The door stop **300** functions as a stop for the door slab **128**, not allowing it to swing through the opening without damage to the hinges.

**[0018]** FIG. 1 shows the frame **110** in an unfolded or installation orientation, where each member of the frame (the jambs **120**, **122** and the horizontal header **124**) contains a front section and back section. The hinge side jamb **120** contains a front section **120a** and a back section **120b**; the lock side jamb **122** contains a front section **122a** and a back section **122b**; and the horizontal header **124** contains a front section **124a** and a back section **124b**. Each of the front sections **120a**, **122a**, and **124a** are joined by one or more hinges **130** to its respective back section **120b**, **122b**, **124b**. The hinge **130** may be a living hinge (a thin flexible section connecting the front section **120a**, **122a**, or **124a** to its corresponding back section **120b**, **122b**, or **124b**) when the frame **110** is made of resilient plastic, such as polypropylene ethylene (PPE), high density polyethylene (HDPE), polyethylene, nylon, polyvinyl chloride (PVC), or combinations thereof, or a resilient composite material, such as wood composite (e.g. particle board or fiberboard), polymer based composites (e.g. fiberglass/polyester resin or wood fiber/polyethylene), or

combinations thereof, or may be a flexible material, such as a strap or a tape (as best shown in FIG. 1). The living hinge may be formed separately from the resilient plastic material and attached to the front and back sections, e.g. by adhesive. Such a separate living hinge, as illustrated in FIG. 6, contains a thin section 600 between two thicker sections 602, 604. The thick sections 602, 604 are attached to the front section 120a, 122a, or 124a and its corresponding back section 120b, 122b, or 124b. The thin section 600 allows the front section 120a, 122a, or 124a and back sections 120b, 122b, or 124b to be folded on each other. Alternatively, the hinges 130 may be conventional mechanical hinges, such as bi-fold metal hinges. When in an opened position ready for installation, as shown in FIG. 1, the front and back sections of each member of the frame 110 lay edge-to-edge with the back edge of the front section abutting the front edge of the back section, such that the hinges 130 lay flat on the outside of the frame 110. When a door slab 128 is present, it is preferably hingedly attached to the back section 120b of the hinge side door jamb 120. The hinge 130 may extend the complete span of the jamb 120, 122 and horizontal header 124, or may be applied in selected portions of the jamb 120, 122 and horizontal header 124.

[0019] For storage and shipping, the door frame 110 may be folded by laying the front sections 120a, 122a, 124a and back sections 120b, 122b, 124b of the door frame 110 one on top of the other, as best shown in FIG. 2. In an embodiment, the front sections 120a, 122a, 124a are folded back on the hinges 130, so that they lay on their corresponding back sections 120b, 122b, 124b. The front section 124a of the horizontal header 124 lays on the outside face of the back section 124b; the front section 120a of the lock side jamb 120 lays on the outside face of the back section 120b; and the front section 122a of the hinge side jamb 122 lays on the outside face

of the back section **122b**. When folded as illustrated in FIG. 2 (folded position), the door frame **110** has a reduced footprint and takes up less room front-to-back for convenient storage.

[0020] When ready for installation, the frame **110** is placed in the opened orientation, as best shown in FIG. 1, by folding the front sections **120a**, **122a**, **124a** forwardly (toward the front of the door frame **110**) and away from their corresponding back sections **120b**, **122b**, **124b**. The front sections **120a**, **122a** of the door jambs **120**, **122** may then be secured to either ends of the front section **124a** of the horizontal header **124** by mechanical fasteners, such as screws, nails, brackets, or combinations thereof. Alternatively, the front sections **120a**, **122a**, **124a** may be secured directly to the wall opening without being secured to each other.

[0021] In certain embodiments, the front sections **120a**, **122a**, **124a** may be secured to their corresponding back sections **120b**, **122b**, **124b** via an interlock mechanism, where each front section **120a**, **122a**, or **124a** contains a protrusion that snaps into and locks with a complementary channel in its respective back section **120b**, **122b**, or **124b**. Of course, the reverse may also be effected, where the back section **120b**, **122b**, or **124b** contains the protrusion, and the front section **120a**, **122a**, or **124a** contains the channel. An exemplary embodiment is shown in FIG. 3, where the front section **120a** contains a protrusion **302**, and the back section **120b** contains a channel **304** formed between the jamb **120a** and its associated door stop **300**. The door stop **300** is preferably mounted to the back sections **120b**, **122b**, **124b**. When the door jamb **120** is placed in its opened orientation, the protrusion **302** fits into the channel **304** to interlock together the front and back sections **120a**, **120b**, respectively. As illustrated in FIG. 3, the protrusion **302** may contain a beveled edge **310** to allow the back section **120b** to slide easily into the channel **304**.

[0022] In certain embodiments, the jamb **120** may also be held in its opened position by a tongue **306** on the door stop **300** that is lodged in a groove **308** in the back section **120b**. Preferably, the tongue **306** and the groove **308** are configured so that the tongue **306** fits snugly into the groove **308** to hold the jamb **120** in its opened position without significant play. Likewise, it is preferred that the protrusion **302** and the channel **304** fit together snugly to hold the back section **120b** and the front section **120a** tightly together. In other embodiments, however, the tongue **306** and groove **308** may be eliminated (as best shown in FIG. 4). Although FIG. 3 shows the interlock mechanism for the hinge side jamb **120**, the same may be effected for the lock side jamb **122** and the horizontal header **124**. Other interlocking mechanisms also be apparent to those skilled in the art.

[0023] In certain embodiments, the door frame may **110** may be installed in a wall opening that has a thickness which does not match that of the door frame **110**. The thickness of the opening may be greater or less than the thickness of the door frame **110** (in its opened orientation). For example, as illustrated in FIG. 4, the thickness  $T$  of the opening may be greater than the thickness  $t$  of the door frame **110** in its opened orientation. In that case, a kit may be provided to replace the front sections **120a**, **122a**, **124a** of the frame **110** with longer front sections **120c**, **122c**, **124c** to match the thickness  $T$  of the opening. As best shown in FIG. 5, to match the thickness  $T$  of the opening, the front section **120a**, having depth  $L_b$ , of the hinge side jamb **120**, may be replaced with a substitute front section **120c**, having depth  $L_c$ , wherein  $L_c$  is greater than  $L_b$ . Of course, the front sections **122a** and **124a** may also be replaced with corresponding substitute front sections **122c** and **124c**. Thus, the kit contains three substitute front sections: a first substitute front section **120c** for the hinge side jamb **120**, a second substitute front section **122c** for the lock side jamb **122**, and a third substitute front section **124c**

for the horizontal header **124**. The substitute front sections **120c**, **122c**, **124c** replace the front section **120a**, **122a**, and **124a**, respectively. Although, FIG. 5 shows the substitute front section **120c** having a depth  $L_c$  greater than  $L_b$ , the reverse case ( $L_c$  less than  $L_b$ ), is also contemplated, where the original frame **110** (in its opened orientation) has a thickness  $t$  greater than the thickness  $T$  of the wall opening. Preferably, the substitute front sections **120c**, **122c**, **124c** contain the same interlock mechanism described above for the front sections **120a**, **122a**, and **124a**, including protrusions **302** and grooves **308** to allow the substitute front sections **120c**, **122c**, **124c** to interlock with their respective back sections **120b**, **122b**, **124b** and door stop **300** (see FIG. 3).

**[0024]** During installation, if the thickness  $T$  of the building opening does not match the thickness  $t$  of the door frame **110**, the installer may obtain a kit having substitute front sections **120c**, **122c**, **124c** to match the thickness  $t$  of the frame with the thickness  $T$  of the opening. The installer may remove the front sections **120a**, **122a**, **124a** from the frame **110**, e.g. by cutting or removing hinges **130**. The substitute front sections **120c**, **122c**, **124c** are then used to replace front sections **120a**, **122a**, **124a** to increase (or decrease) the thickness of the frame **110**. The installer may slide the substitute front sections **120c**, **122c**, **124c** in place adjacent to their respective back sections **120b**, **122b**, **124b** and door stop **300**, secure the substitute front jamb sections **120c**, **122c** to the substitute front header section **124c** (e.g. by fasteners, such as screws, nails, brackets, or combinations thereof), and optionally reinstall hinges **130** to secure the substitute front sections **120c**, **122c**, **124c** to their respective back sections **120b**, **122b**, **124b**. Alternatively, a tape may be used to secure the substitute front sections **120c**, **122c**, **124c** to their respective back sections **120b**, **122b**, **124b**.

[0025] Although certain presently preferred embodiments have been specifically described herein, it will be apparent to those skilled in the art that variations and modifications of the various embodiments shown and described herein may be made without departing from the spirit and scope of the teachings herein.

**EMBODIMENTS IN WHICH AN EXCLUSIVE PROPERTY OR PRIVILEGE IS CLAIMED ARE DEFINED AS FOLLOWS:**

1. A door frame, including:

a hinge side jamb parallel to a lock side jamb; and

a horizontally extending header jamb,

said hinge side and lock side jamb being spaced apart and vertically extending, said header jamb connected to top ends of the hinge side and lock side jamb,

each of the jambs has a front section and an adjacent back section,

a hinge joins said front and back sections so that said front sections and said back sections are configured to be folded onto each other when oriented in a folded position,

each of said hinge side jamb, said lock side jamb, and said header jamb includes a door stop, all of the door stops positioned on the associated back section,

a channel configured in each of said hinge side jamb, said lock side jamb, and said header jamb between the back section and said door stop,

each front section of said hinge side jamb, said lock side jamb, and said header jamb includes a protrusion,

each protrusion configured to fit into the associated channel to interlock the front section to the associated back section when said front sections and said back sections are oriented in an opened position.

2. The frame of claim 1, wherein said jambs have a reduced thickness portion forming said hinge.
3. The frame of claim 2, wherein each of said jambs comprises plastic or composite material.
4. The frame of claim 1, wherein said hinge is a tape, a strap, or a bifold hinge.
5. The frame of claim 1, wherein said hinge side jamb and said lock side jamb comprise polymer composite or wood composite.
6. The frame of claim 1, wherein said hinge is configured to allow each front section to be folded onto the associated back section.

7. The frame of claim 1, wherein said hinge side jamb and said lock side jamb are flat jambs.
8. The frame of claim 1, wherein the door stop contains a tongue and each back section contains a groove, the tongue configured to fit into the groove.
9. The frame of claim 1, further including a substitute kit having a substitute front section for each of the jambs and the header, the substitute front section configured to replace its respective front section to increase or decrease the depth of the frame in its opened position.
10. The frame of claim 9, wherein the substitute front sections have a depth that is different than the depth of the front section.
11. The frame of claim 9, wherein the substitute kit further including fasteners for securing the substitute front and back sections together.
12. The frame of claim 1, wherein each protrusion contains a beveled edge configured to allow the back section to slide into the channel.
13. The frame of claim 1, wherein each channel extends partially through the associated jamb and each protrusion extends from a portion of the associated jamb.
14. The frame of claim 13, wherein the channels are oriented on a first side of the frame and the hinges are on an opposite second side of the frame.

15. The frame of claim 1, wherein there are a plurality of hinges for each jamb.
16. The frame of claim 1, wherein each channel extends inwardly into the associated jamb and each protrusion extends outwardly from the associated jamb into the associated channel.
17. The frame of claim 1, wherein each protrusion has a portion abutting a face of the associated channel.
18. A pre-hung door assembly, including:
  - a) the door frame of any one of claims 1-17; and
  - b) a door slab mounted to the hinge side jamb.
19. The pre-hung door assembly of claim 18, wherein said hinge is one of a bi-fold hinge, a living hinge integral with the associated jamb, and a resilient member.
20. A method for installing a pre-hung door assembly, the method comprising:
  - a) providing the pre-hung door assembly of claim 18 or 19;
  - b) unfolding the front and back sections of the jambs such that the protrusions fit into the channels to form an interlock; and

- c) inserting and securing the unfolded pre-hung door assembly into a wall opening.

**21.** A method for installing a pre-hung door assembly, the method comprising:

- a) providing a pre-hung door assembly including
  - i) a frame containing a hinge side jamb, a lock side jamb, and a horizontal header jamb, the hinge side and lock side jambs disposed in spaced parallel relation and the header jamb connecting top ends of the hinge side and lock side jambs, wherein each of the jambs is made of a front section and an adjacent back section joined by a hinge configured to allow the front and back sections to be folded, and
  - ii) a door slab mounted to the hinge side jamb;
- b) unfolding the front and back sections of the jambs; and
- c) inserting and securing the unfolded pre-hung door assembly into a wall opening.

**22.** The method of claim **21**, further including the steps of removing the front sections of the door jambs and replacing the front sections of the door jambs with substitute front sections.

**23.** The method of claim **22**, further including the steps of securing the replacement front sections to the back sections.

24. The method of claim 21, wherein the hinge is one of a bi-fold hinge, a living hinge integral with the associated jamb, and a resilient member.
25. The method of claim 21, wherein the jambs have a reduced thickness portion forming said hinge.
26. The method of claim 25, wherein each of the jambs comprises plastic or composite material.
27. The method of claim 21, wherein the hinge is a tape, a strap, or a bifold hinge.
28. The method of claim 21, wherein the hinge side jamb and the lock side jamb each comprise polymer composite or wood composite.
29. The method of claim 21, wherein the hinge is configured to allow each front section to be folded onto the associated back section.
30. The method of claim 21, wherein the hinge side jamb and the lock side jamb are flat jambs.
31. The method of claim 21, wherein each back section of each of the hinge side jamb, lock side jamb, and horizontal header has an attached or integral door stop.

32. The method of claim 21, further including the step of replacing each front section with a substitute front section.
33. The method of claim 32, wherein the substitute front section has a different depth than the front section.
34. The method of claim 32, wherein the substitute front section is provided as a kit along with the pre-hung door assembly.
35. A method for installing a pre-hung door assembly, the method comprising:
  - a) providing a pre-hung door assembly including:
    - i) a frame having a hinge side jamb, a lock side jamb, and a horizontal header jamb, the hinge side and lock side jambs disposed in spaced parallel relation and the header jamb connecting top ends of the hinge side and lock side jambs, wherein each of the jambs is made of a front section and an adjacent back section joined by a hinge configured to allow the front and back sections to be folded, wherein each back section of each of the hinge side jamb, lock side jamb, and horizontal header has an attached or integral door stop, and

- ii) a door slab mounted to the hinge side jamb, wherein each front section and associated back section are secured together via an interlock mechanism;
  - b) unfolding the front and back sections of the jambs; and
  - c) inserting and securing the unfolded pre-hung door assembly into a wall opening.
- 36.** The method of claim **35**, wherein each front section has a protrusion, each back section has a channel, and the protrusion locks with the associated channel and the door stop.
- 37.** The method of claim **36**, wherein each front section has a tongue and each back section has a groove.
- 38.** The method of claim **35**, further including the step of replacing each front section with a substitute front section.
- 39.** The method of claim **38**, wherein the substitute front section has a different depth than the front section.
- 40.** The method of claim **38**, wherein the substitute front section is provided as a kit along with the pre-hung door assembly.
- 41.** A door frame, including:

a hinge side jamb,

a lock side jamb parallel to the hinge side jamb, and

a header jamb,

wherein said hinge side and lock side jambs being spaced apart and vertically extending,

said horizontal header jamb connected to top ends of the hinge side and lock side jambs,

each of the jambs has a front section and an adjacent back section,

a hinge joins said front and back sections so that said front sections and said back sections are configured to be folded onto each other when oriented in a folded position,

wherein each front section and associated back section are secured together via an interlock mechanism when oriented in an open position.

- 42.** The frame of claim **41**, wherein said jambs have a reduced thickness portion forming said hinge.

43. The frame of claim 42, wherein each of said jambs comprises plastic or composite material.
44. The frame of claim 41, wherein said hinge is a tape, a strap, or a bifold hinge.
45. The frame of claim 41, wherein said hinge side jamb and said lock side jamb comprise polymer composite or wood composite.
46. The frame of claim 41, wherein said hinge is configured to allow each front section to be folded onto the associated back section.
47. The frame of claim 41, wherein said hinge side jamb and said lock side jamb are flat jambs.
48. The frame of claim 41, wherein each back section of each of said hinge side jamb, lock side jamb, and a horizontal header has an attached or integral door stop.
49. The frame of claim 48, wherein each front section has a protrusion and each back section has a channel, the protrusion configured to lock with the associated channel and the door stop.
50. The frame of claim 49, wherein each front section has a tongue and each back section has a groove.

- 51.** The frame of claim **41**, further including a substitute kit having a substitute front section for each of the jambs and the header, the substitute front section configured to replace its respective the front section to increase or decrease the depth of the frame in its the opened position.
- 52.** The frame of claim **51**, wherein the substitute front sections have a depth that is different than the depth of the front section.
- 53.** The frame of claim **51**, wherein the substitute kit further including fasteners for securing the substitute front and back sections together.
- 54.** A pre-hung door assembly, including:
- a) the frame of claim **41**; and
  - b) a door slab mounted to the hinge side jamb.
- 55.** The pre-hung door assembly of claim **54**, wherein said hinge is one of a bi-fold hinge, a living hinge integral with the associated jamb, and a resilient member.
- 56.** The pre-hung door assembly of claim **54**, wherein each of the front sections has a contoured portion and each of the back sections has a contoured portion complementary to the associated front section contoured portions.

- 57.** The pre-hung door assembly of claim **56**, wherein one of the contoured portions is a protrusion and the other of the contoured portions is a channel.
- 58.** The pre-hung door assembly of claim **57**, wherein each of the jambs includes a stop configured to limit pivoting of said door slab, each stop including a tongue and each front section including a groove, wherein each tongue is secured within the associated groove.
- 59.** A method for installing a pre hung door assembly, including the steps of:
- a) providing a the pre-hung door assembly of claim **54**, wherein the front and the back sections of the jambs are in the folded position;
  - b) unfolding the front and back sections of the jambs to provide an unfolded pre-hung door assembly; and
  - c) inserting and securing the unfolded pre-hung door assembly into a wall opening.
- 60.** The method of claim **59**, further including the step of replacing the front sections of the jambs and the header with substitute front sections to increase the depth of the frame in its opened position.

1/6

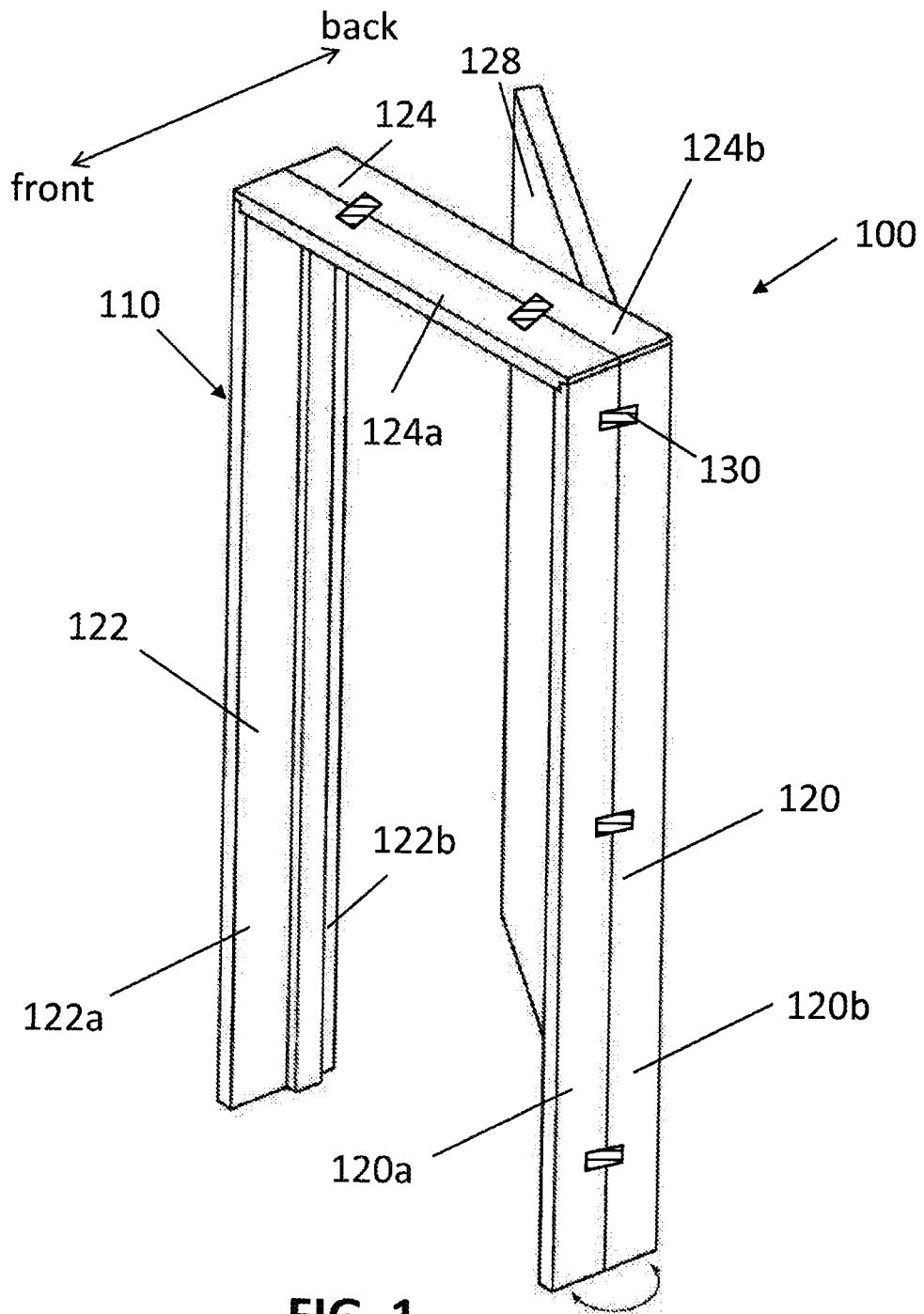

**FIG. 1**

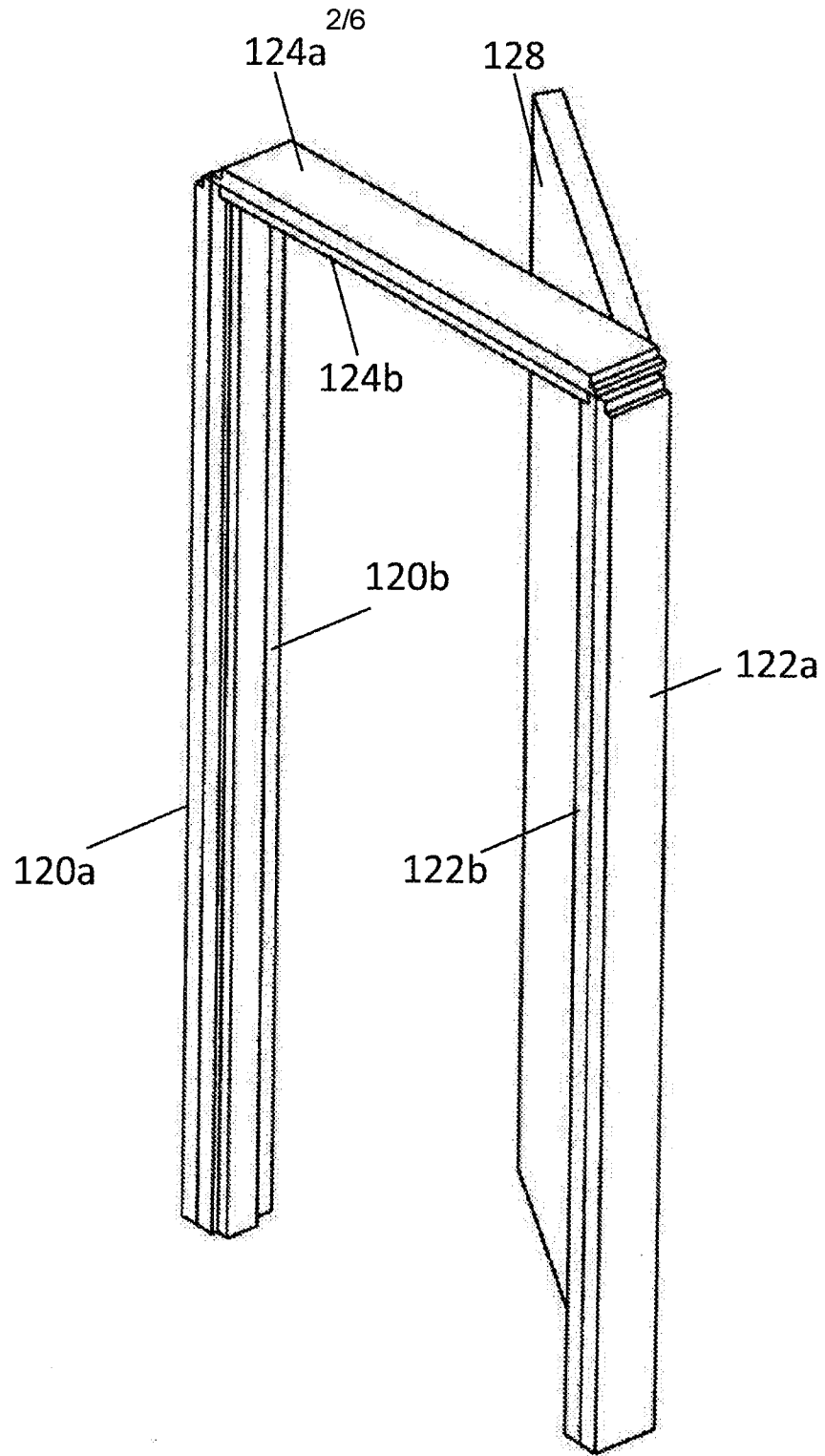
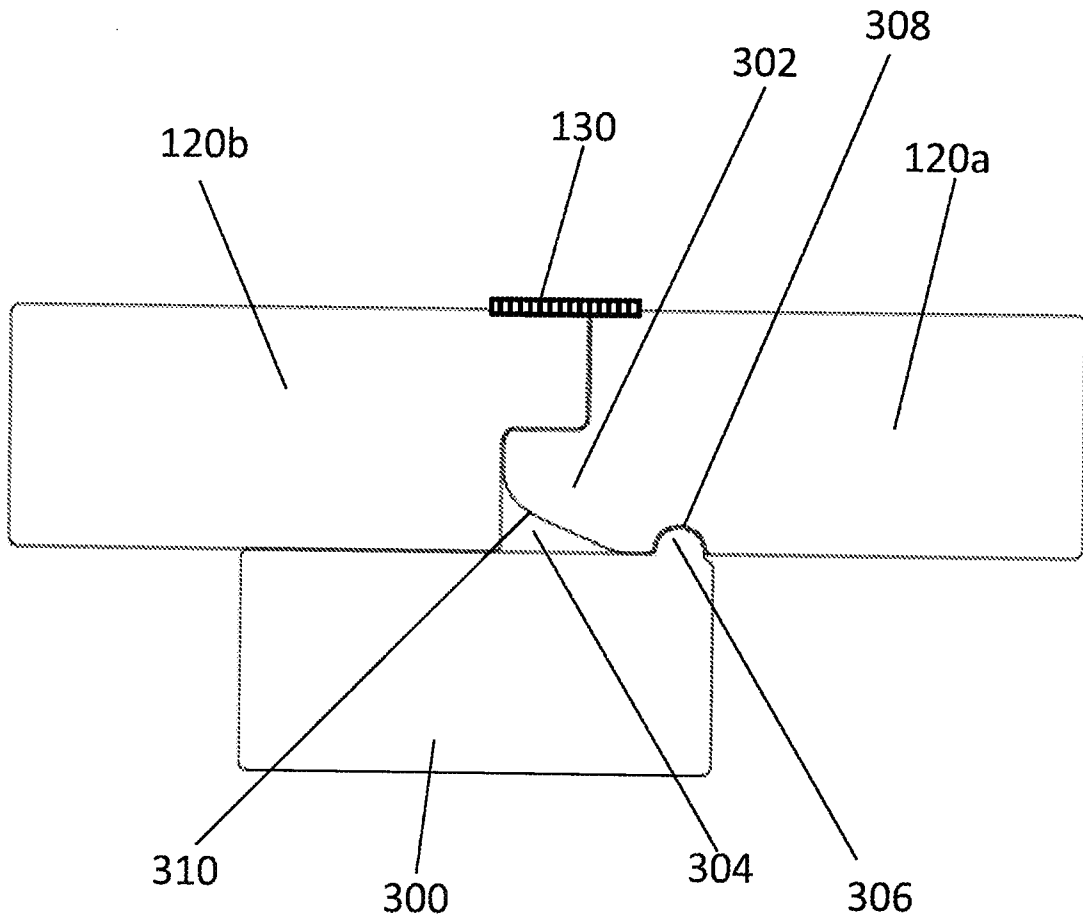
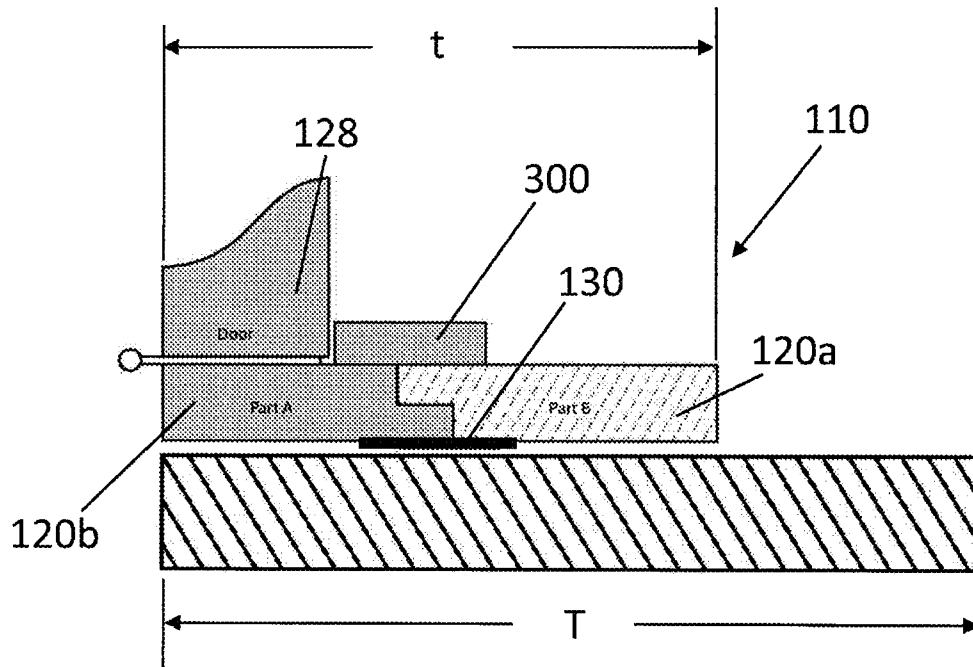

FIG. 2



**FIG. 3**

**FIG. 4**

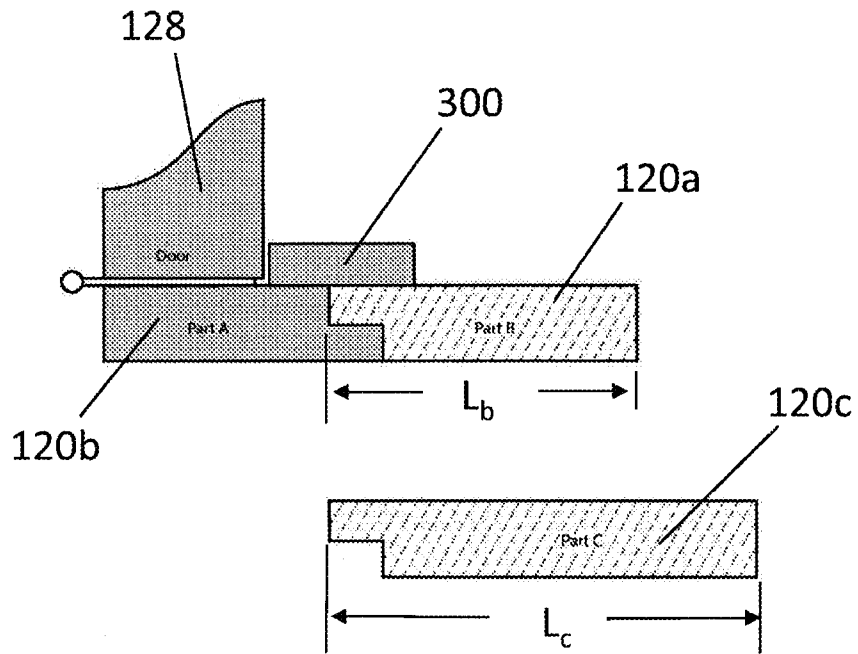
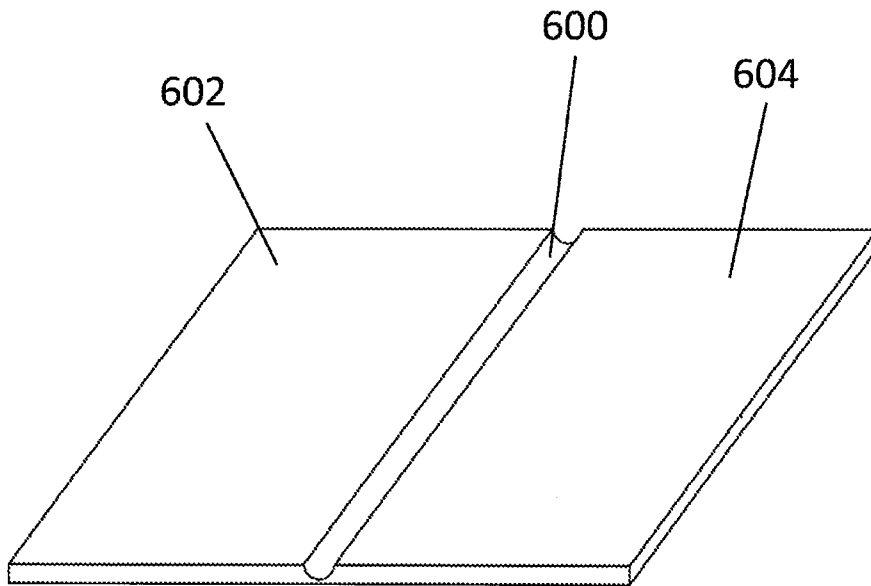

FIG. 5



**FIG. 6**

