



- (51) International Patent Classification: *A61B 17/90* (2006.01)
- (21) International Application Number: PCT/US2014/027086
- (22) International Filing Date: 14 March 2014 (14.03.2014)
- (25) Filing Language: English
- (26) Publication Language: English
- (30) Priority Data: 61/793,212 15 March 2013 (15.03.2013) US
- (71) Applicant: **PARAGON 28, INC.** [US/US]; 4B Inverness Court E., Suite 280, Englewood, Colorado 80112 (US).
- (72) Inventors: **DACOSTA, Albert**; 9601 Silent Hills Lane, Lone Tree, Colorado 80124 (US). **BONO, Frank**; 12218 Dunsmuir Lane, Arlington, Tennessee 38002 (US). **HOUGHTON, M.D., Michael**; 2500 Prospect Road, Fort Collins, Colorado 80525 (US). **SANGIOVANNI, M.D., Thomas**; 1150 Campo Sano Avenue, Suite 200, Miami, Florida 33146 (US). **CLANCY, DPM, James T.**; 4801 South Congress Avenue, Lake Worth, Florida 33461 (US). **CHANG, DPM, Thomas**; 208 Concourse Blvd., Santa Rosa, California 95403 (US).
- (74) Agent: **GRAFF, Jacquelyn A.**; Heslin Rothenberg Farley & Mesiti P.C., 5 Columbia Circle, Albany, New York 12203 (US).
- (81) Designated States (unless otherwise indicated, for every kind of national protection available): AE, AG, AL, AM, AO, AT, AU, AZ, BA, BB, BG, BH, BN, BR, BW, BY, BZ, CA, CH, CL, CN, CO, CR, CU, CZ, DE, DK, DM, DO, DZ, EC, EE, EG, ES, FI, GB, GD, GE, GH, GM, GT, HN, HR, HU, ID, IL, IN, IR, IS, JP, KE, KG, KN, KP, KR, KZ, LA, LC, LK, LR, LS, LT, LU, LY, MA, MD, ME, MG, MK, MN, MW, MX, MY, MZ, NA, NG, NI, NO, NZ, OM, PA, PE, PG, PH, PL, PT, QA, RO, RS, RU, RW, SA, SC, SD, SE, SG, SK, SL, SM, ST, SV, SY, TH, TJ, TM, TN, TR, TT, TZ, UA, UG, US, UZ, VC, VN, ZA, ZM, ZW.
- (84) Designated States (unless otherwise indicated, for every kind of regional protection available): ARIPO (BW, GH, GM, KE, LR, LS, MW, MZ, NA, RW, SD, SL, SZ, TZ, UG, ZM, ZW), Eurasian (AM, AZ, BY, KG, KZ, RU, TJ, TM), European (AL, AT, BE, BG, CH, CY, CZ, DE, DK, EE, ES, FI, FR, GB, GR, HR, HU, IE, IS, IT, LT, LU, LV, MC, MK, MT, NL, NO, PL, PT, RO, RS, SE, SI, SK, SM, TR), OAPI (BF, BJ, CF, CG, CI, CM, GA, GN, GQ, GW, KM, ML, MR, NE, SN, TD, TG).

[Continued on next page]

(54) Title: INTRAMEDULLARY NAIL FIXATION GUIDES, DEVICES, AND METHODS OF USE

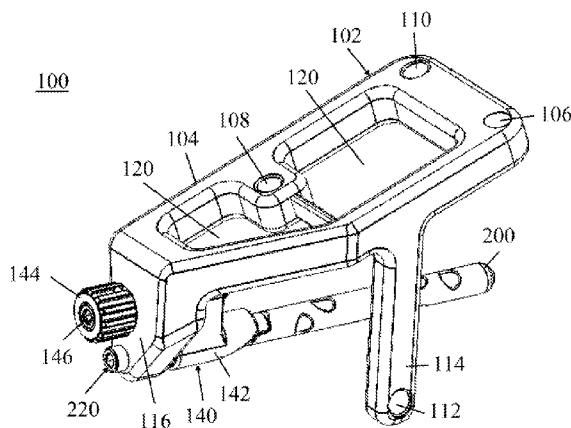

FIG. 1

(57) Abstract: Fixation guide devices and methods for positioning and inserting an intramedullary nail are disclosed. The fixation guide devices include a frame with a first end and a second end, a compression device removably coupled to the first end of the frame, and the intramedullary nail secured to a nail attachment apparatus of the frame. An intramedullary nail including a body with a fastening end, a closed end, and at least two openings is also disclosed. A compression device includes a compression member, a knob, and a bolt secured in the knob and rotatably engaging the compression member is also disclosed. An alignment guide is disclosed and includes a base member, an alignment member, and a fixation guide. A method of inserting an intramedullary nail into two bones for fixation of the two bones is also disclosed.

WO 2014/152219 A2

Published:

- *without international search report and to be republished upon receipt of that report (Rule 48.2(g))*

INTRAMEDULLARY NAIL FIXATION GUIDES, DEVICES, AND METHODS OF USE

CROSS REFERENCE

5 This application claims priority benefit under 35 U.S.C. §119(e) of U.S. provisional application No. 61/793,212 filed March 15, 2013, which is incorporated herein by reference in its entirety.

TECHNICAL FIELD

10 The present disclosure relates generally to the field of orthopedics related to fixation of prepared joint surfaces using intramedullary nail fixation guides, devices, and methods.

BACKGROUND OF THE INVENTION

15 The current technology utilizes plate and screw fixation that needs a balance between strength and plate profile. The soft tissue coverage of the joints in question is not sufficient to prevent irritation from thick plates and screw heads. In addition, the attachment of tendons and other anatomical considerations cause most plating to occur at the dorsal surface of the joint which is the “compression side” and very little can be done to prevent “gapping” at the plantar surface which is the “tension side.” Therefore, plating needs to be very thin to prevent soft tissue irritation and the need for a second operation to remove the plating. As the position of implantation is on the compression side weight bearing must be postponed for six to eight weeks to prevent hardware and fusion failure. Prolonged periods of non-weight bearing create increased probability of compromised healing.

20 Accordingly, the present invention contemplates new and improved intramedullary nail fixation guides, devices, and methods which overcome the above-referenced problems and others.

SUMMARY OF THE INVENTION

25 The present invention is directed toward devices and methods for use in fixation of a patient’s joints or for fixation of a fracture. The fixation guides provide an orientation for insertion of intramedullary nails through a patient’s joint or fracture to maximize the strength of the joint and bones based on the length of the nail and to minimize weakening of the bone for better plantar stabilization.

30 In one aspect of the present invention provided herein, is a fixation guide device for positioning and inserting an intramedullary nail. The fixation guide device includes a frame with a first end and a second end. The fixation guide device also includes a compression

device removably coupled to the first end of the frame. In addition, the fixation guide device includes the intramedullary nail secured to a nail attachment apparatus of the frame.

In another aspect of the present invention provided herein, is an intramedullary nail including a body with a first end and a second end. The body includes a fastening end at the first end, a closed end at the second end, and at least two openings positioned oblique to the longitudinal axis of the body between the first end and the second end of the body. The fastening end includes an insertion opening extending from the first end into the body along a longitudinal axis of the body.

In another aspect of the present invention provided herein, is a compression device for compressing a joint with an implant. The compression device includes a compression member, a knob, and a bolt secured in the knob and rotatably engaging the compression member.

In yet another aspect of the present invention provided herein, is an alignment guide including a base member, an alignment member, and a fixation guide. The base member includes a first portion and a second portion with the second portion extending out from the first portion in a relatively perpendicular direction and the first portion including at least one opening. The alignment member including at least one opening, being coupled to the base member, and angled relative to the second portion of the base member. The fixation guide removably inserted through one of the at least one openings in the first portion of the base member.

In a further aspect of the present invention provided herein, is a method of inserting an intramedullary nail into two bones for fixation of the two bones. The method may include creating an incision near the two bones and preparing the two bones for fixation. The method may further include securing an alignment guide to the two bones to position a guidewire across the two bones. Next, the method may include drilling over the guidewire to create a cavity for the intramedullary nail to pass through the two bones. The intramedullary nail includes a securing screw hole at a first end of the intramedullary nail and at least two peg holes. The method may also include obtaining a fixation guide device. The fixation guide device includes a frame with at least two drill holes and a compression device. The method may further include attaching the intramedullary nail to the compression device of the fixation guide device and inserting the intramedullary nail into the cavity. The method may also include inserting a drill sleeve into a first drill hole at a second end of the fixation guide device and drilling a first opening that aligns with a first peg hole in the second end of the intramedullary nail. Next, the method may include inserting a first peg into the first opening

and through the first peg hole. The method may then include using the first peg and compression device to compress the two bones. The method may further include inserting the drill sleeve into a second drill hole at the first end of the fixation guide device and drilling a second opening that mates with a second peg hole in the first end of the intramedullary nail.

5 The method may also include inserting a second peg into the second opening and through the second peg hole to secure the two bones in compression. Further, the method may include detaching the intramedullary nail from the fixation guide and removing the fixation guide device. The method may also include inserting a locking screw into the securing screw hole. Finally, the method may include closing the incision.

10 These and other objects, features and advantages of this invention will become apparent from the following detailed description of the various aspects of the invention taken in conjunction with the accompanying drawings.

BRIEF DESCRIPTION OF THE DRAWINGS

The accompanying drawings, which are incorporated in and constitute a part of the specification, illustrate embodiments of the invention and together with the detailed
15 description herein, serve to explain the principles of the invention. It is emphasized that, in accordance with the standard practice in the industry, various features are not drawn to scale. In fact, the dimensions of the various features may be arbitrarily increased or reduced for clarity of discussion. The drawings are only for purposes of illustrating preferred
20 embodiments and are not to be construed as limiting the invention.

FIG. 1 shows an isometric view from the lateral side of one embodiment of an implant fixation guide, in accordance with an aspect of the present invention;

FIG. 2 shows an isometric view from the medial side of the fixation guide of FIG. 1, in accordance with an aspect of the present invention;

25 **FIG. 3** shows an isometric view from the lateral side of an outrigger assembly of the fixation guide of FIG. 1, in accordance with an aspect of the present invention;

FIG. 4 is an isometric view from the medial side of the outrigger assembly of FIG. 3, in accordance with an aspect of the present invention;

FIG. 5 is a front isometric view of a compression member of the fixation guide of
30 FIG. 1, in accordance with an aspect of the present invention;

FIG. 6 is a side isometric view of the compression member of FIG. 5, in accordance with an aspect of the present invention;

FIG. 7 shows a front isometric view of a compression device knob of the fixation guide of FIG. 1, in accordance with an aspect of the present invention;

FIG. 8 is a side isometric view of a compression device bolt of the fixation guide of FIG. 1, in accordance with an aspect of the present invention;

5 **FIG. 9** is an isometric view of an intramedullary nail of the fixation guide of FIG. 1, in accordance with an aspect of the present invention;

FIG. 10 is a side view of the intramedullary nail of FIG. 9, in accordance with an aspect of the present invention;

10 **FIG. 11** shows an isometric view of an intramedullary nail engagement fastener of the fixation guide of FIG. 1, in accordance with an aspect of the present invention;

FIG. 12 is an isometric view of an intramedullary nail locking screw of the fixation guide of FIG. 1, in accordance with an aspect of the present invention;

FIG. 13 is an isometric view of a guidewire alignment guide mounted onto a foot of a patient, in accordance with an aspect of the present invention;

15 **FIG. 14** is a rear isometric view of the guidewire alignment guide of FIG. 13, in accordance with an aspect of the present invention;

FIG. 15 is an isometric view showing the guidewire alignment guide of FIG. 14 mounted onto the foot of the patient with three guidewires inserted into the patient's bone, in accordance with an aspect of the present invention;

20 **FIG. 16** is an isometric view of one of the three guidewires inserted into the patient's foot across a joint, in accordance with an aspect of the present invention;

FIG. 17 is an isometric view of the foot of FIG. 16 showing the cavity for insertion of an intramedullary nail, in accordance with an aspect of the present invention;

25 **FIG. 18** shows a side view of the foot of FIG. 17 with an intramedullary nail inserted into the cavity, in accordance with an aspect of the present invention;

FIG. 19 shows an isometric side view of the embodiment of FIG. 18 including a drill sleeve inserted into a first position in the fixation guide, in accordance with an aspect of the present invention;

30 **FIG. 20** shows an isometric view of the drill sleeve of FIG. 19, in accordance with an aspect of the present invention;

FIG. 21 is an isometric view of a peg for securing an intramedullary nail in the patient's foot, in accordance with an aspect of the present invention;

FIG. 22 shows a side isometric view of the embodiment of FIG. 19 including a first peg inserted into the patient's foot and the compression device for compressing the joint, in accordance with an aspect of the present invention;

5 **FIG. 23** is an isometric side view of the embodiment of FIG. 22 including a drill sleeve inserted into a second position in the fixation guide of FIG. 1, in accordance with an aspect of the present invention;

FIG. 24 is an isometric side view of the embodiment of FIG. 23 including a second peg inserted into the patient's foot, in accordance with an aspect of the present invention;

10 **FIG. 25** is an isometric side view of the embodiment of FIG. 24 including a drill sleeve inserted into a third position in the fixation guide of FIG. 1, in accordance with an aspect of the present invention;

FIG. 26 is an isometric side view of the embodiment of FIG. 25 showing the opening for the third peg, in accordance with an aspect of the present invention;

15 **FIG. 27** is an isometric side view of the embodiment of FIG. 26 including a third peg inserted into the patient's foot, in accordance with an aspect of the present invention;

FIG. 28 is an isometric side view of the embodiment of FIG. 27 including a drill sleeve inserted into a fourth position in the fixation guide of FIG. 1, in accordance with an aspect of the present invention;

20 **FIG. 29** is an isometric side view of the embodiment of FIG. 28 showing the fourth opening for the fourth peg, in accordance with an aspect of the present invention;

FIG. 30 is an isometric side view of the embodiment of FIG. 29 including a fourth peg inserted into the patient's foot, in accordance with an aspect of the present invention;

FIG. 31 is an isometric side view of the embodiment of FIG. 30 with the fixation guide of FIG. 1 removed, in accordance with an aspect of the present invention;

25 **FIG. 32** is an isometric side view of the embodiment of FIG. 31 showing the locking screw inserted into an intramedullary nail, in accordance with an aspect of the present invention;

FIG. 33 shows an isometric view from the medial side of another fixation guide, in accordance with an aspect of the present invention;

30 **FIG. 34** shows an isometric view from the lateral side of the fixation guide of FIG. 33, in accordance with an aspect of the present invention;

FIG. 35 is an isometric view from the top-medial side of an outrigger assembly of the fixation guide of FIG. 33, in accordance with an aspect of the present invention;

FIG. 36 is an isometric view from the bottom-lateral side of the outrigger assembly of FIG. 4, in accordance with an aspect of the present invention;

FIG. 37 is a front isometric view of a compression member of the fixation guide of FIG. 33, in accordance with an aspect of the present invention;

5 **FIG. 38** is a top isometric view of the compression member of FIG. 37, in accordance with an aspect of the present invention;

FIG. 39 is an isometric view of an embodiment of an intramedullary nail of the fixation guide of FIG. 33, in accordance with an aspect of the present invention;

10 **FIG. 40** is a side view of the intramedullary nail of FIG. 39, in accordance with an aspect of the present invention;

FIG. 41 is an isometric view of an intramedullary nail locking screw of the fixation guide of FIG. 33, in accordance with an aspect of the present invention;

FIG. 42A is an isometric view of a guidewire alignment guide mounted onto a patient's foot with guidewires, in accordance with an aspect of the present invention;

15 **FIG. 42B** is an isometric left side view of the guidewire alignment guide and guidewires of FIG. 42A, in accordance with an aspect of the present invention;

FIG. 42C is an isometric right side view of the guidewire alignment guide of FIG. 42A, in accordance with an aspect of the present invention;

20 **FIG. 42D** is an exploded view of the guidewire alignment guide of FIG. 42A, in accordance with an aspect of the present invention;

FIG. 42E is a top view of the guidewire alignment guide of FIG. 42A, in accordance with an aspect of the present invention;

FIG. 42F is a side view of the guidewire alignment guide of FIG. 42A, in accordance with an aspect of the present invention;

25 **FIG. 43A** is an isometric view of another guidewire alignment guide mounted onto a foot of a patient, in accordance with an aspect of the present invention;

FIG. 43B is a side isometric view of the guidewire alignment guide of FIG. 43A, in accordance with an aspect of the present invention;

30 **FIG. 44** is an isometric view of the foot of FIG. 42A showing the cavity for insertion of the intramedullary nail of FIG. 39, in accordance with an aspect of the present invention;

FIG. 45 shows a side view of the foot of FIG. 44 with the intramedullary nail of FIG. 39 inserted into the cavity, in accordance with an aspect of the present invention;

FIG. 46 shows an isometric side view of the embodiment of FIG. 45 including the four drill sleeves inserted into the drill holes of the fixation guide of FIG. 35, in accordance with an aspect of the present invention;

5 **FIG. 47** shows an isometric view of the drill sleeves of FIG. 46, in accordance with an aspect of the present invention;

FIG. 48 is a side isometric view of the embodiment of FIG. 46 showing the four pegs inserted into the patient's foot, in accordance with an aspect of the present invention;

FIG. 49 is an isometric view of a first peg for securing the intramedullary nail of FIG. 39 in the patient's foot, in accordance with an aspect of the present invention;

10 **FIG. 50** is an isometric view of a second peg for securing the intramedullary nail of FIG. 39 in the patient's foot, in accordance with an aspect of the present invention;

FIG. 51 is an isometric view of a third peg for securing the intramedullary nail of FIG. 39 in the patient's foot, in accordance with an aspect of the present invention;

15 **FIG. 52** is an isometric view of a fourth peg for securing the intramedullary nail of FIG. 39 in the patient's foot, in accordance with an aspect of the present invention;

FIG. 53 is an isometric side view of the embodiment of FIG. 48 with the fixation guide of FIG. 33 removed from the patient's foot, in accordance with an aspect of the present invention;

20 **FIG. 54** is an isometric side view of the embodiment of FIG. 53 showing the locking screw inserted into the intramedullary nail of FIG. 39, in accordance with an aspect of the present invention;

FIG. 55 depicts one embodiment of a method of inserting an intramedullary nail into a joint for fixation of the joint, in accordance with an aspect of the present invention;

25 **FIG. 56** is an isometric view of another intramedullary nail implant with two fasteners inserted, in accordance with an aspect of the present invention;

FIG. 57 is an isometric view of the intramedullary nail implant of FIG. 56 wherein the implant is transparent showing the openings and the compression cam, in accordance with an aspect of the present invention;

30 **FIG. 58** is an isometric view of the intramedullary nail implant of FIG. 56 with four fasteners inserted into the nail implant, in accordance with an aspect of the present invention; and

FIG. 59 is an isometric view of the intramedullary nail implant of FIG. 56 implanted into a patient's bones, in accordance with an aspect of the present invention.

DETAILED DESCRIPTION FOR CARRYING OUT THE INVENTION

In this application, the words proximal, distal, anterior or plantar, posterior or dorsal, medial and lateral are defined by their standard usage for indicating a particular part or portion of a bone or prosthesis coupled thereto, or directional terms of reference, according to the relative disposition of the natural bone. For example, “proximal” means the portion of a bone or prosthesis nearest the torso, while “distal” indicates the portion of the bone or prosthesis farthest from the torso. As an example of directional usage of the terms, “anterior” refers to a direction towards the front side of the body, “posterior” refers to a direction towards the back side of the body, “medial” refers to a direction towards the midline of the body and “lateral” refers to a direction towards the sides or away from the midline of the body. Further, specifically in regards to the foot, the term “dorsal” refers to the top of the foot and the term “plantar” refers the bottom of the foot.

Similarly, positions or directions may be used herein with reference to anatomical structures or surfaces. For example, as the current devices, instrumentation and methods are described herein with reference to use with the bones of the foot, the bones of the foot, ankle and lower leg may be used to describe the surfaces, positions, directions or orientations of the devices, instrumentation and methods. Further, the devices, instrumentation and methods, and the aspects, components, features and the like thereof, disclosed herein are described with respect to one side of the body for brevity purposes. However, as the human body is relatively symmetrical or mirrored about a line of symmetry (midline), it is hereby expressly contemplated that the devices, instrumentation and methods, and the aspects, components, features and the like thereof, described and/or illustrated herein may be changed, varied, modified, reconfigured or otherwise altered for use or association with another side of the body for a same or similar purpose without departing from the spirit and scope of the invention. For example, the devices, instrumentation and methods, and the aspects, components, features and the like thereof, described herein with respect to the right foot may be mirrored so that they likewise function with the left foot. Further, the devices, instrumentation and methods, and the aspects, components, features and the like thereof, disclosed herein are described with respect to the foot for brevity purposes, but it should be understood that the devices, instrumentation, and methods may be used with other bones of the body having similar structures, for example the upper extremity, and more specifically, with the bones of the wrist, hand, and arm.

Referring to the drawings, wherein like reference numerals are used to indicate like or analogous components throughout the several views, and with particular reference to FIGS.

1-2, there is illustrated an exemplary embodiment fixation guide device **100**. The fixation guide device **100** includes an outrigger assembly or frame **102** which may be coupled to a compression device **140** and an intramedullary nail **200**. In the embodiment depicted in FIGS. 3-4, the outrigger assembly **102** includes a base **104** with a first drill hole **106**, a second drill hole **108**, a third drill hole **110**, a second or lateral arm **114** with a fourth drill hole **112**, and a first or distal arm **116**. It is also contemplated that the frame **102** may include, for example, a plurality of drill holes **106**, **108**, **110**, **112** as necessary to secure the intramedullary nail **200** across a joint or fracture. The drill holes **106**, **108**, **110**, **112** may each include, for example, multiple holes spaced a small distance apart or multiple nested or overlapping holes to correspond to the openings **208**, **210**, **212**, **214** in multiple size intramedullary nails **200**. The frame **102** may include a first end and a second end. The base **104** may include at least one opening **120** allowing for visualization through the base **104** with imaging technology, such as x-rays, and a bracket **122**, as seen in FIG. 3, for stabilization of the fixation guide device **100** where the opening **120** is large. The bracket **122** may provide stability to the base **104** allowing for alignment of the fasteners for insertion in the nail **200**. The distal arm **116** is perpendicular to the base **104** at the distal end and includes a knob opening or first opening **124**, a nail attachment opening or second opening **126**, and a nail attachment portion or apparatus **128**. The nail attachment portion **128** includes an end with an inverted two step profile including a first step or first nail attachment segment **180** extending a first distance and a second step or second nail attachment segment **182** extending a second distance. The first distance is greater than the second distance. The base **104** is ideally made of a material that is strong enough to prevent deformation during surgery, such as a metal, while also being radiolucent to allow for imaging through the base **104** to determine if correct alignment of the nail **200** was achieved. The base **104** may be made of, for example, carbon fiber.

The compression device **140** slidably mates with the nail attachment portion **128**. The compression device **140** includes a compression member **142**, a knob **144**, and a bolt **146**. As best seen in FIGS. 5-6, the compression member **142** has a base **158** with a top end **148** and a bottom end **150**. The compression member **142** also includes a protrusion **160** at the bottom end **150**. A first opening **152** is near the top end **148** for receiving bolt **146**. The first opening **152** is threaded to mate with a threaded end **156** of bolt **146**. A second opening **154** is near the bottom end **150** and passes through the base **158** and protrusion **160**. The second opening **154** is slidably engaged with the nail attachment portion **128**. The proximal end of the compression member **142** is angled from a point between the top and midline of

the protrusion **160** to approximately a midpoint **162** of the bottom end **150** of the base **158** of the compression member **142**. The angled portion of the protrusion **160** may include teeth **164** for engaging a patient's bone.

As depicted, after the compression member **142** is slid over nail attachment portion **128**, the knob **144** may be secured to the base **104** using a bolt **146** and a fastener (not shown). The knob **144** is shown in FIG. 7 and bolt **146** is illustrated in FIG. 8. The threaded end **156** of bolt **146** is inserted into knob opening **124** and the threaded end **156** mates with the threads of the second opening **154**. The bolt **146** also includes a stop member **166** and a smooth end **168**. The stop member **166** prevents bolt **146** from passing through knob opening **124**. The smooth end **168** of bolt **146** may be inserted into an opening **176** in the knob **144**. The bolt **146** and knob **144** are locked in place with a fastener (not shown), such as a pin, clip, or the like, inserted through opening **170** of the knob **144** and bolt opening or opening **172**. Opening **170** is generally perpendicular to opening **176** and passes through the entire knob **144**. The knob **144** may also include ridges **178** on an exterior surface to aide in the rotation of the knob **144** by the surgeon.

Referring now to FIGS. 9-10 with continued reference to FIGS. 1-2, the intramedullary nail **200** includes a body **202** with a closed end **204**, a fastening end **206**, and four openings **208**, **210**, **212**, **214**. The four openings **208**, **210**, **212**, **214** may be disposed on independent planes and angularly spaced apart relative to each other. By placing the four openings **208**, **210**, **212**, **214** at opposing angles oblique to the longitudinal axis of the nail **200**, the amount of longitudinal and rotational movement of the nail **200** is limited. It is also contemplated that the intramedullary nail **200** may include any number of openings **208**, **210**, **212**, **214** as may be necessary to secure the nail to a patient's bones. The fastening end **206** includes an insertion opening **216** and an engagement opening **218**. The insertion opening **216** is a threaded opening along a longitudinal axis in the center of the nail **200** parallel to the exterior surface of the nail **200**. The insertion opening **216** is used to secure the nail **200** to the nail attachment portion **128** using an engagement fastener **220**, such as a screw. The engagement opening **218** may include a central axis that is generally transverse the longitudinal axis of the nail **200**. As illustrated in FIG. 11, the engagement fastener **220** includes a head **222** with a drive opening **224** and a shank **226** that is partially threaded including a smooth portion **228** and a threaded portion **230**. The drive opening **224** may be, for example, hexagonal, square, Phillips or another multi-lobed configuration for coupling with an insertion instrument. The engagement fastener **220** is inserted through opening **126**

and passes through the nail attachment portion **128** before being screwed into the insertion opening **216** to secure nail **200** to the nail attachment portion **128**.

The engagement opening **218** of the nail **200** may be a threaded opening that passes through the exterior surface of nail **200** to secure the nail **200** to the bone using a fastener, such as a locking screw **232**. The locking screw **232** is depicted in FIG. 12 and includes a head **234** with a drive opening **236** and a shank **238** with a first threaded section **240**, a smooth section **242**, and a second threaded section **244**. The drive opening **236** may be, for example, a Phillips opening, a flat head opening, a hexagonal opening, or other multi-lobed configuration. The second threaded section **244** is designed to engage the patient's bone.

The first threaded section **240** of the locking screw **232** is threaded to correspond to the threads **246** of the engagement opening **218** to secure the nail **200** in place inside the patient's bones. The first threaded section **240** may have a larger diameter than the second threaded section **244** allowing for the second threaded section **244** to pass through the opening **218** without engaging the threads **246**. Alternatively, the first threaded section **240** and second threaded section **244** may have the same diameters such that the second threaded section **244** would mate with the threads **246** as it passes through the opening **218**. For example, the threads of the first threaded section **240** and second threaded section **244** may have the same pitch to allow both the first threaded section **240** and second threaded section **244** to mate with opening **218**. In order to provide for thread differentiation between the first threaded section **240** and second threaded section **244** the second threaded section **244** may have a single lead thread and the first threaded section **240** may include a double lead thread in order to improve bone purchase.

The nail **200** may also include a fastening end **206** with a shape that corresponds to the shape of the end of the nail attachment portion **128** to create a tight fit between the nail **200** and the attachment portion **128**. As depicted in FIGS. 9-10, the fastening end **206** may have a two step profile including a first step or first fastening segment **248** and a second step or second fastening segment **250**. When the nail **200** is secured to the outrigger assembly **102** the first fastening segment **248** aligns with second nail attachment segment **182** and second fastening segment **250** aligns with first nail attachment segment **180**. The engagement fastener **220** may then be inserted to secure the nail **200** to the outrigger assembly **102**. The step profiles of the nail **200** and the nail attachment portion **128** provide additional stability to the nail **200** during insertion into the patient's bone and prevent nail **200** from rotating during insertion of the pegs and screws.

The surgical method for inserting the intramedullary nail **200** into a patient's joint **260** may include the steps of FIG. 55, as illustrated in FIGS. 13-32. The method utilizes some of the devices, instruments, features, aspects, components, and the like described above, and therefore reference will be made to the above described embodiments, such as the illustrated
5 embodiments presented in the figures and discussed above. However, such references are made for exemplary purposes only and are not intended to limit the surgical method beyond the specifically recited steps. Further, the surgical method may be discussed under the umbrella of particular bones, but such an application is not intended to be limiting and the method described herein may be used or conducted with bone or other tissue not specifically
10 discussed herein without departing from the spirit and scope of the surgical method.

If a joint **260**, for example, a proximal tarsal-metatarsal joint or the like, needs to be surgically fixed, a surgeon would first expose the joint **260** by creating an incision over the joint **260** shown in step **352**. Next, in step **354**, the first bone **262** and second bone **264** of the joint **260** will be prepared by using a cut guide and cartilage removal technique such as curet,
15 osteotome, saw blade, or other similar cartilage removal technique known by one skilled in the art. The joint **260** is then aligned by moving the first bone **262** and second bone **264** into a desired position for fixation. Once the bones **262**, **264** are aligned, temporary fixation may be applied to hold the joint **260** in the desired position. A guidewire, template, or similar clamp may be used to temporarily fix the joint **260**.

Next, in step **356**, as seen in FIG. 13, a guidewire alignment guide **270** is positioned
20 onto the first bone **262** with the first end **272** of the alignment guide **270** aligned with the proximal end, for example, the dorsal ridge, of the first bone **262** at the joint **260** to align the guide **270**. The alignment guide **270**, shown in FIG. 14, may include a first opening **282** on the proximal end of the guide **270**, a second opening **284** on the lateral side of the guide **270**,
25 and a third opening **286** on the front of the distal end of the guide **270**. As seen in FIG. 14, the guidewire alignment guide **270** may also include a rim **266** at the first end **272** that mates with the edge of the first bone **262** to hold the alignment guide **270** in place. In addition, the alignment guide **270** may include teeth **268** for mating with the first bone **262** to maintain a desired position while inserting the guidewires **276**. A handle **274** may add additional
30 stability to hold the alignment guide **270** in position while guidewires **276**, **278**, **280** are inserted into the bone. The guidewires **276**, **278**, **280** may be, for example, K-wires.

Referring now to FIG. 15, the first guidewire **276** may then be inserted through first opening **282** and into the proximal end of the first bone **262**. The guide **270** may be rotated about the first guidewire **276** if necessary for proper alignment. The second guidewire **278**

may be inserted through second opening **284** and into the medial side of the first bone **262**. The third guidewire **280** may be inserted through the third opening **286** and across the joint **260**. The third guidewire **280** may be positioned to be used as a drilling guide for the intramedullary nail **200**. Once the third guidewire **280** is inserted across the joint **260** the first
5 guidewire **276**, second guidewire **278**, and guidewire alignment guide **270** may be removed, leaving the third guidewire **280** in position for drilling a cavity for the nail **200**, as illustrated in FIG. 16.

A depth gauge (not shown) may then be used to measure the length of the guidewire **280** inserted into the bones **262**, **264** to determine the length of intramedullary nail **200**
10 needed. Once the length of the guidewire **280** that is inserted into the bones **262**, **264** is determined three millimeters is subtracted from the measured length to account for compression of the joint **260**. After subtracting three millimeters, the length of the intramedullary nail **200** that should be used is known. Next, in step **258**, a drill may be used to drill over the guidewire **280** to create a cavity **288** for the intramedullary nail **200**. The
15 diameter of the drill used should correspond to the size of the intramedullary nail **200** that was selected for insertion into the joint **260**. The drill may include measurement gradients lasered onto the drill bit to allow for reading of the depth drilled. Once the desired depth is reached to fit the selected intramedullary nail **200**, the drill and guidewire **280** may be removed leaving cavity **288** for insertion of the intramedullary nail **200**, as illustrated in FIG.
20 17.

Next, in step **360**, a fixation guide device **100** may be selected. Then in step **362**, the nail **200** may be loaded onto the outrigger assembly **102** of the fixation guide device **100** by aligning the first step **180** and second step **182** of the nail attachment portion **128** with the second step **250** and the first step **248** of the nail **200**, respectively. Once the nail attachment
25 portion **128** and nail **200** are aligned, an engagement fastener **220** may be inserted into opening **126** to secure the nail **200** to the outrigger assembly **102** creating the fixation guide device **100** for use during insertion and fixation of the nail **200** into the cavity **288**, as depicted in FIGS. 1 and 2. Referring now to FIG. 18, the fixation guide device **100** is then oriented to allow the surgeon to insert the nail **200** into the pre-drilled cavity **288**. The nail
30 **200** is advanced in the cavity **288** until a positive stop is reached on the guide device **100**. When the nail **200** reaches the positive stop it will be countersunk in the cavity **288** approximately three millimeters (3 mm) preventing prominence of the nail **200** after compression has occurred and the nail **200** is in its final position.

Next, in step **366**, as shown in FIG. 19, a drill sleeve **290** may be inserted into the first drill hole **106**. The drill sleeve **290** including a sleeve portion **292** with a stop member **294** at the top and an opening **296** through the center of the sleeve portion **292**, as depicted in FIG. 20. The opening **296** may have a diameter the size of the drill bit used to drill a cavity **298** in the second bone **264**. The drill bit passes through the first opening **208** in the nail **200** when the cavity **298** is drilled. After the cavity **298** is drilled a depth gauge may be inserted into the cavity **298** through drill sleeve **290** to measure the depth of the cavity **298**. Then the depth gauge and drill sleeve **290** may be removed from the first drill hole **106**. Using the measured depth the surgeon may select a first peg **300** having the desired length. The first peg **300** may then be inserted through the first drill hole **106** and into the cavity **298**, as shown in FIG. 22. The first peg **300** may be inserted relatively perpendicular to the nail **200**. Referring now to FIG. 21, the pegs or fasteners **300**, **320**, **330**, and **340** include a shaft **302** with a proximal end and a distal end. The proximal end includes a head **304**, an upper threaded section **306**, and a notch **308**. In the depicted embodiment the head **304** is a hexagonal head although other head shapes, such as, a flat head, Phillips head, and the like are also contemplated. The distal end includes a lower threaded section **310** with a pointed end **312** and a notch **314**. Between the proximal end and the distal end of the shaft **302** there may be a smooth region which mates with the first opening **208** of the nail **200**. The upper threaded section **306** of the pegs **300**, **320**, **330**, and **340** may be substantially flush with the exterior surface of the bones **262**, **264**. Alternatively, the pegs **300**, **320**, **330**, and **340** may be countersunk below the surface of the bones **262**, **264**.

In step **368**, the first peg **300** may then be used as a counter force for compression as knob **144** is turned forcing compression member **142** to move proximally and exert force on the first bone **262** as the first peg **300** holds the second bone **264** in place. As the compression member **142** is moved the first bone **262** and second bone **264** may be compressed at joint **260**. Once the desired compression is achieved, next in step **370**, a second peg **320** may be inserted by inserting the drill sleeve **290** into a second drill hole **108** and drilling a second cavity **322** into the first bone **262**, as illustrated in FIG. 23. The second cavity **322** will pass through second opening **210** in the nail **200**. After the second cavity **322** is drilled a depth gauge may be inserted into the second cavity **322** through drill sleeve **290** to measure the depth of the second cavity **322**. Then the depth gauge and drill sleeve **290** may be removed from the second drill hole **108**. Using the measured depth the surgeon selects a second peg **320** having the desired length. The second peg **320** may then be inserted through the second drill hole **108** and into the second cavity **322**, as shown in FIG. 24. The second

peg **320** may be inserted relatively perpendicular to the nail **200**. The insertion of the second peg **320** will secure the achieved compression to prevent the loss of compression.

Referring now to FIG. 25, a drill sleeve **290** may be inserted into the third drill hole **110**. A drill may then be inserted into opening **296** in drill sleeve **290** to drill a third cavity **332** into the second bone **264**, as illustrated in FIG. 26. The third cavity **332** passes through the third opening **212** in the nail **200**. After the third cavity **332** is drilled a depth gauge may be inserted into the third cavity **332** through drill sleeve **290** to measure the depth of the third cavity **332**. Then the depth gauge and drill sleeve **290** may be removed from the third drill hole **110**. Using the measured depth the surgeon may select a third peg **330** with the desired length. The third peg **330** may then be inserted through the third drill hole **110** and into third cavity **332**, as shown in FIG. 27. The third peg **330** may be inserted relatively perpendicular to the nail **200**. The insertion of the third peg **330** may add additional stability to the compression of the first bone **262** and second bone **264**.

A drill sleeve **290** may be inserted into the fourth drill hole **112**, as illustrated in FIG. 28. A drill may then be inserted into the opening **296** in the drill sleeve **290** to drill a fourth cavity **342** into the first bone **262**. The fourth cavity **342**, as best seen in FIG. 29, passes through the fourth opening **214** in the nail **200**. After the fourth cavity **342** is drilled a depth gauge may be inserted into the fourth cavity **342** through drill sleeve **290** to measure the depth of the fourth cavity **342**. Then the depth gauge and drill sleeve **290** may be removed from the fourth drill hole **112**. Using the measured depth the surgeon may select a fourth peg **340** with the desire length. The fourth peg **340** may then be inserted through the fourth drill hole **112** and into the fourth cavity **342**, as illustrated in FIG. 30. The fourth peg **340** may be inserted relatively perpendicular to the nail **200**. The insertion of the fourth peg **340** may provide additional stability to the compression of the first bone **262** and the second bone **264**.

Next, in step **372**, as shown in FIG. 31, after the four pegs **300**, **320**, **330**, **340** are inserted into the first and second bones **262**, **264**, respectively, the outrigger assembly **102** may be detached from the nail **200** and removed from the foot. Next, in step **374**, a locking drill guide may be threaded for inserting the locking screw **232** into the first bone **262** through the opening of the intramedullary nail **200**. Once the locking drill guide is secured, a drill may be passed through an opening in the locking drill guide and the engagement opening **218** to create a cavity **350** for the locking screw **232**. After the cavity **350** is drilled the locking drill guide may be removed. A depth gauge may then be inserted into the cavity **350** to measure the depth of the cavity **350**. Using the measured depth the surgeon may select a locking screw **232**. The selected locking screw **232** may then be inserted into the cavity

350 to secure the nail 200 in position in the first bone 262 and the second bone 264. After the locking screw 232 is inserted the position and stability of the nail 200 may be verified using fluoroscopy. Once the position of the nail 200 is verified a cap 252 may be inserted into the fastening end 206 to prevent bone ingrowth or overgrowth in order to maintain the ability to
5 remove nail 200 if necessary or desired. The cap may include securing means to secure the cap to the nail 200 to prevent disengagement of the cap. Next, in step 376, the incision over the joint 260 may be closed by the surgeon.

Referring now to FIGS. 33-54, with specific reference to FIGS. 33 and 34 showing an exemplary embodiment fixation guide device 400. The fixation guide device 400 may
10 include an outrigger assembly or frame 402, a compression device 440, and an intramedullary nail 500. The outrigger assembly 402, shown in FIGS. 35 and 36, includes a base 404 with a lateral wing or outwardly extending wing 414 including a first drill hole 406, a second drill hole 408, a third drill hole 410, a fourth drill hole 412, and a proximal arm 416. It is also contemplated that the frame 402 may include, for example, a plurality of drill holes to
15 correspond to the number of openings in an intramedullary nail, for example, nail 200, 500, 700 in order to secure the intramedullary nail to the patient's bones. The drill holes 406, 408, 410, 412 may each include, for example, multiple holes spaced a small distance apart or multiple nested or overlapping holes to correspond to the openings 508, 510, 512, 514 in various sized intramedullary nails 500. The base 404 may include at least one opening 420
20 allowing for visualization through the base 404 with imaging technology, such as x-ray. The proximal arm 416 is perpendicular to the base 404 at a proximal end of the outrigger assembly 402 and includes a knob opening 424, a nail attachment opening 426, and a nail attachment portion 428. The nail attachment portion 428 may include an end with an inverted two step profile including a first step or nail attachment segment 480 and a second
25 step or nail attachment segment 482. The base 404 may ideally be made of a material that is strong enough to prevent deformation during surgery, such as, a metal, while also being radiolucent, for example, carbon fiber, to allow for imaging through the base 404 to determine whether correct alignment of the nail 500 was achieved.

The compression device 440 slidably mates with the nail attachment portion 428.
30 The compression device 440 includes a compression member 442, a knob 444, and a bolt 446. As best seen in FIGS. 37-38, the compression member 442 has a base 458 with a top end 448 and a bottom end 450. The compression member 442 also includes a protrusion 460 at the bottom end 450, a first opening 452 near the top end 448 for receiving the bolt 446, and a second opening 454 near the bottom end 450 passing through the base 458 and protrusion

460. The compression member **442** may be of the type described above with reference to the compression member **142** and will not be described again here for brevity sake. The second opening **454** is slidably engaged with the nail attachment portion **428**. The compression member **442** may also include a midpoint **462** and teeth **464** on the angled portion of the protrusion **460**, as described above with reference to compression member **142**.

As depicted, after the compression member **442** is slid over nail attachment portion **428**, the knob **144** may be secured to the base **404** using a bolt **146** and fastener inserted into opening **170**. The knob **144**, shown in FIG. 7, and the bolt **146**, illustrated in FIG. 8, are both described above with reference to the fixation guide device **100**. The threaded end **156** of bolt **146** may be inserted into the knob opening **424** and the threaded end **156** mates with the threads of the second opening **454**. The stop member **166** of the bolt **146** may prevent the bolt **146** from passing through the knob opening **424**.

Referring now to FIGS. 39-40 with continued reference to FIGS. 33-34, the intramedullary nail **500** may be of the type described above with reference to nail **200** and may include a body **502** with a closed end **504**, a fastening end **506** with an insertion opening **516** and an engagement opening **518**, and four openings **508**, **510**, **512**, **514**. It is also contemplated that the intramedullary nail **500** may include any number of openings **508**, **510**, **512**, **514** as may be necessary to secure the nail to a patient's bones. The insertion opening **516** may be used to secure the nail **500** to the nail attachment portion **428** using an engagement fastener **220**, for example, a screw, such as the one illustrated in FIG. 11.

The engagement opening **518** may be a threaded opening, with threads **546**, that passes through the exterior surface of nail **500** to secure the nail **500** to the bone using a locking screw **532**. The locking screw **532**, as depicted in FIG. 41, may include a head **534** with a drive opening **536** and a shank **538** with a first threaded section **540**, a smooth section **542**, and a second threaded section **544**, as described above with reference to locking screw **232** and which will not be described again here for brevity sake.

The nail **500** may also include a fastening end **506** with a shape that corresponds to the shape of the end of the nail attachment portion **428** to create a tight fit between the nail **500** and the attachment portion **428**. As depicted in FIGS. 39-40, the fastening end **506**, may be of the type described above with reference to fastening end **206**, and includes a two step profile including a first step or fastening segment **548** and a second step or fastening segment **550**. Thus, the nail **500** may be secured to the outrigger assembly **402**, as described above with reference to FIGS. 9-10.

The surgical method for inserting the intramedullary nail **500** into a patient's joint **560** may include the steps of FIG. 55, as illustrated in FIGS. 42A-54. The method utilizes some of the devices, instruments, features, aspects, components, and the like described above with reference to the fixation guide device **400**, and therefore reference will be made to the above described embodiments illustrated in FIGS. 33-41 and discussed above. However, such references are made for exemplary purposes only and are not intended to limit the surgical method beyond the specifically recited steps. Further, the surgical method may be discussed under the umbrella of particular bones, but such an application is not intended to be limiting and the method described herein may be used or conducted with bone or other tissue not specifically discussed herein without departing from the spirit and scope of the surgical method.

If a joint **560**, for example, a metatarsal phalangeal joint or the like, needs to be surgically fixed, a surgeon would first expose the joint **560** by creating an incision over the joint **560** as in step **352**. Next, in step **354**, the first bone **262** and the third bone **564** of the joint **560** will be prepared by using a cut guide and cartilage removal technique such as a curet, osteotome, saw blade, or other similar cartilage removal technique known by one skilled in the art. The joint **560** is then aligned by moving the first bone **262** and third bone **564** into a desired position for fixation. Once the bones **262**, **564** are aligned, temporary fixation may be applied to hold the joint **560** in the desired position. A guidewire, template, or similar clamp may be used to temporarily fix the joint **560**.

Next, in step **356**, shown in FIG. 42A, an alignment guide **522**, as illustrated in FIGS. 42B-42F, is aligned with the patient's first bone **262** and third bone **564**. The alignment guide **522** includes a base member **524** with an alignment member **526** and a fixation guide or temporary fixation guide **528**. The base member **524** includes a first member and a second member. The alignment member **526** couples to the base member **524** for alignment of the first bone **262** and the third bone **564**. The alignment member **526** may be coupled to the base member **524** by, for example, pins **552** on the alignment member **526** which engage openings **554** on the base member **524**, as shown in FIG. 42D. When the alignment member **526** is coupled to the base member **524** the alignment portion **558** aligns the alignment member **526** relative to the second member of the base member **524**. The alignment portion **558** may be angled at a desired angle, which may range from, for example, approximately 0 degrees to 25 degrees and more preferably from approximately 10 degrees to 15 degrees. The alignment portion **558** allows a surgeon to maintain the desired alignment of the first bone **262** and third bone **564** of the patient's toe.

Once the guide **522** is aligned, at least two guidewires **530** may be inserted into through holes or openings **556** to temporarily fix the guide **522** to the first bone **262** and third bone **564**. After temporarily fixing the guide **522** to the first and third bones **262**, **564** the fixation guide **528** may be inserted into one of the holes **566** in the first member of the base member **524** providing the desired path through the patient's joint. The fixation guide **528** may include a head **568**, a shaft **570** extending out from the head **568** and a through hole **572** extending through the center of the head **568** and the shaft **570**. After inserting the fixation guide **528** into the desired hole **566** a guidewire **530** may be inserted into the through hole **572** of the temporary fixation guide **528** and into the bone **262** and third bone **564** across the joint. The guidewire **530** inserted into the temporary fixation guide **528** may be positioned to be used as a drilling guide for the intramedullary nail **500**. Once the guidewire **530** is inserted across the joint **560** the alignment guide **522** may be removed, leaving the guidewire **530** in position for drilling a cavity for the nail **500**.

Alternatively, step **356** may be performed as shown in FIG. 43A, using the alignment guide **576**, as illustrated in FIG. 43B, wherein the guide **576** is aligned with the patient's first bone **262**. The alignment guide **576** includes a body **578** with a distal end which includes a pointed end **580** and a drill guide portion **582** at the proximal end of the body **578**. The drill guide portion **582** includes a bone mating portion **584** and a center channel **586** for the drill to pass through. The pointed end **580** aligns with the distal end of the first bone **262**. Once the guide **576** is aligned, a guidewire may be inserted through a center channel **586** and into the distal end **562** of the first bone **262** and the third bone **564**. The guidewire may be positioned to be used as a drilling guide for the intramedullary nail **500**. Once the guidewire is inserted across the joint **560** the alignment guide **576** may be removed, leaving the guidewire in position for drilling a cavity for the nail **500**.

A depth gauge (not shown) may then be used to determine the length of the intramedullary nail **500** to be used, as described above with reference to determining the length of nail **200**, which will not be described again here for brevity sake. Next, in step **358**, a cavity **588** for the nail **500** is drilled, as described above with reference to drilling cavity **288**, and nail **500** is inserted, as illustrated in FIG. 44.

Next, in step **360**, a fixation guide device **400** may be selected. Then, in step **362**, as depicted in FIGS. 33 and 34, the nail **500** may then be loaded onto the outrigger assembly **402** creating the fixation guide device **400** for use during insertion and fixation of the nail **500** into the cavity **588**, as described above with reference to nail **200** and outrigger assembly **102**. Next, in step **364**, as shown in FIG. 45, the fixation guide device **400** may then be

oriented to allow the surgeon to insert the nail **500** into the pre-drilled cavity **588**, as described above with reference to insertion of nail **200**, which will not be described again here for brevity sake. The nail **500** may be countersunk in the cavity **588**, approximately two to three millimeters depending on pre-operative assessment.

5 Referring now to FIG. 46, drill sleeves **590** are shown inserted into a first drill opening **406**, a second drill opening **408**, a third drill opening **410**, and a fourth drill opening **412** of the base **404**. The drill sleeves **590** include a sleeve portion **592** with a stop member **594** at the top and an opening **596** through the center of the sleeve portion **592**, as depicted in FIG. 47. The diameter of the opening **596** may be the same size as the drill bit used to drill
10 cavities into the first and second bones **262**, **564**. The cavities are drilled through the opening **596** in the drill sleeve **590** and the openings **508**, **510**, **512**, and **514** in the nail **500**.

Referring now to FIGS. 46 and 48, the nail **500** is shown fixed into the bones **262**, **564** using four pegs or fasteners **600**, **620**, **640**, and **660**. Referring now to FIGS. 49-52, the first peg **600**, second peg **620**, third peg **640**, and fourth peg **660** each include a shaft **602**, **624**,
15 **644**, **664**, respectively, with a proximal end and a distal end. The proximal ends include a head **604**, **626**, **646**, **666**, an upper threaded section **606**, **628**, **648**, **668**, and a notch **608**, **630**, **650**, **670**. In the depicted embodiment the heads **604**, **626**, **646**, **666** may be hexagonal heads, although other head shapes, such as, a flathead, Phillips head, other multi-lobed configurations, and the like are also contemplated. The distal ends include a lower threaded
20 section **610**, **632**, **652**, **672** with a pointed end **612**, **634**, **654**, **674** and a notch **614**, **636**, **656**, **676**. Between the proximal ends and distal ends of the shafts **602**, **624**, **644**, **664** there may be a smooth region which mates with the first opening **508**, second opening **510**, third opening **512**, fourth opening **514**, respectively, of the nail **500**.

Once the nail **500** is inserted into the cavity **588** it will be secured to the bones **262**,
25 **564** using at least two pegs, in the depicted embodiment four pegs **600**, **620**, **640**, and **660** are used. Next, in step **366**, as shown in FIG. 48, the surgeon may secure the nail **500** by inserting the first peg **600** into a first cavity **598** in the third bone **564**, as described above with reference to drilling, measuring, and inserting the first peg **300**, which will not be described again here for brevity sake.

30 Next, in step **368**, the first peg **600** may then be used as a counter force for compression as knob **144** is turned forcing compression member **442** to move distally and exert force on the first bone **262** as the first peg **600** holds the third bone **564** in place. As compression member **442** is moved the first bone **262** and third bone **564** are compressed at joint **560**. Once the desired compression has been achieved, in step **370**, a second peg **620**

may be inserted using drill sleeve **590** to drill a second cavity **622** in the first bone **262**, as described above with reference to second cavity **322**. After the second cavity **622** is drilled the depth of the cavity **622** may be measured and the length of a second peg **620** selected, as described above with reference to second peg **320** which will not be described again here for
5 brevity sake. The second peg **620** may then be inserted through the second drill opening **408** and into the second cavity **622**, as shown in FIG. 48. The insertion of the second peg **620** may secure the achieved compression to prevent the loss of compression.

With continued reference to FIGS. 46 and 48, the drill sleeve **590** may also be inserted into the third drill hole **410**. A drill may then be inserted into opening **596** in the drill
10 sleeve **590** to drill a third cavity **642** into the third bone **564**. The third cavity **642** may pass through the third opening **512** in nail **500**. After the third cavity **642** is drilled a depth gauge may be inserted into the third cavity **642** through the drill sleeve **590** to measure the depth of the third cavity **642**. Then the depth gauge and the drill sleeve **590** may be removed from the third drill opening **410**. Using the measured depth, the surgeon may select a third peg **640**
15 with the desired length. The third peg **640** may then be inserted through the third drill hole **410** and into the third cavity **642**, as shown in FIG. 48. The insertion of the third peg **640** adds additional stability to the compression of the bones **262**, **564**.

The drill sleeve **590** may also be inserted into the fourth drill hole **412**, as illustrated in FIG. 46. A drill may then be inserted into the opening **596** in the drill sleeve **590** to drill a
20 fourth cavity **662** into the first bone **262**. The fourth cavity **662** may pass through the fourth opening **514** in the nail **500**. After the fourth cavity **662** is drilled a depth gauge may be inserted into the fourth cavity **662** through the drill sleeve **590** to measure the depth of the fourth cavity **662**. Then the depth gauge and the drill sleeve **590** may be removed. Using the measured depth, the surgeon may select a fourth peg **660** with the desire length. The fourth
25 peg **660** may then be inserted through the fourth drill opening **412** and into the fourth cavity **662**, as illustrated in FIG. 48. The insertion of the fourth peg **660** may provide additional stability to the compression of the first bone **262** and the third bone **564**.

Referring now to FIGS. 53 and 54, once at least the first and second peg **600**, **620**,
although all four pegs **600**, **620**, **640**, and **660** are shown in the depicted embodiment, are
30 inserted into the first and third bones **262**, **564**, respectively, nail **500** may be detached from the outrigger assembly **402** and the fixation guide device **400** may be removed from the patient's foot, in step **372**. Next, in step **374**, a threaded locking drill guide may be threaded or not threaded for inserting the locking screw **532** into the first bone **262** through the engagement opening **518** of the intramedullary nail **500**. Once the locking drill guide is

secured, a cavity **680** for the locking screw **532** may be drilled through the engagement opening **518** and the depth measured, as described above with reference to drilling cavity **350** which will not be described again for brevity sake. Using the measured depth, the surgeon may select a locking screw **532** and insert the screw **532** into the cavity **680** to secure the nail **500** in position in the first bone **262** and the third bone **564**. After the locking screw **532** is inserted the position and stability of the nail **500** may be verified using fluoroscopy. Once the position of the nail **500** is verified, a cap may be inserted into the fastening end **506** to prevent bone ingrowth or overgrowth in order to maintain the ability to remove nail **500** if necessary or desired. The cap may also include securing means to secure the cap to the nail **500** to prevent disengagement of the cap. Then, in step **376**, the incision over the joint **560** may be closed by the surgeon.

Alternative intramedullary nails, for example, nail **700**, as shown in FIGS. 56-59, may be used to replace intramedullary nails **200** and **500**. The nail **700** may include a body **702**, a closed end **704**, a compression end or fastening end **706**, and four openings **708**, **710**, **712**, and **714**. The four openings **708**, **710**, **712**, and **714** may be disposed on independent planes and angularly spaced apart relative to each other. The amount of longitudinal and rotational movement of the nail **700** is limited by placing the four openings **708**, **710**, **712**, and **714** at opposing angles oblique to the longitudinal axis of the nail **700**. It is also contemplated that the intramedullary nail **700** may include any number of openings **708**, **710**, **712**, **714** as may be necessary to secure the nail to a patient's bones with limited or no rotational or longitudinal movement after implantation. The second opening **710** may be an elongated opening to enable compression of a joint **732** which is medial the first opening **708** and the second opening **710** and configured to receive fastener **726**. While the first opening **708**, third opening **712**, and fourth opening **714** may be configured to receive fasteners **724**, **728**, **730**, respectively, and prevent movement along the longitudinal axis of the body **702**. Alternative fasteners may also be used with the intramedullary nail **700**, for example, fasteners or pegs **300**, as shown in FIG. 21, and **600**, **620**, **640**, **660**, as shown in FIGS. 49-52. The compression end **706** includes a cam opening or insertion opening **716**, which may be threaded, and a cam or cam member **718** for insertion into the cam opening **716**. The cam **718** may include exterior threads **720** for engaging the threads of the cam opening **716** and a drive opening **722**.

The intramedullary nail **700** may be used during surgery to compress a joint **732**, which may be, for example, joints **260**, **560** described in greater detail above. The nail **700** may be inserted into a patient in place of nails **200** and **500**. Once inserted into a cavity

within the patient's bones 734, 736 which passes through a patient's joint 732, the surgeon may insert a first fastener 724 into the first opening 708 and into the second bone 736. Next a second fastener 726 may be inserted into the first bone 734 through the second or elongated opening 710 at a position within the opening 710 closest to the compression end 706. Then a screw driver, not shown, may be inserted to engage the drive opening 722 of the cam 718 and turned to advance the cam 718 along the cam opening 716. As the cam 718 is advanced along the cam opening 716 into the body 702 of the nail 700, the cam 718 engages the shaft of the second fastener 726, as shown in FIG. 57, and pushes the second fastener 726 along the elongated opening 710 to compress the first bone 734 and second bone 736 of the joint 732. Once the desired compression is achieved, a third fastener 728 may be inserted into the first bone 734 through the third opening 712 to secure the joint 732 in compression. A fourth fastener 730 may be inserted into the second bone 736 through the fourth opening 714 to secure the joint 732 in compression.

The terminology used herein is for the purpose of describing particular embodiments only and is not intended to be limiting of the invention. As used herein, the singular forms "a", "an" and "the" are intended to include the plural forms as well, unless the context clearly indicates otherwise. It will be further understood that the terms "comprise" (and any form of comprise, such as "comprises" and "comprising"), "have" (and any form of have, such as "has", and "having"), "include" (and any form of include, such as "includes" and "including"), and "contain" (and any form of contain, such as "contains" and "containing") are open-ended linking verbs. As a result, a method or device that "comprises," "has," "includes," or "contains" one or more steps or elements possesses those one or more steps or elements, but is not limited to possessing only those one or more steps or elements. Likewise, a step of a method or an element of a device that "comprises," "has," "includes," or "contains" one or more features possesses those one or more features, but is not limited to possessing only those one or more features. Furthermore, a device or structure that is configured in a certain way is configured in at least that way, but may also be configured in ways that are not listed.

The invention has been described with reference to the preferred embodiments. It will be understood that the architectural and operational embodiments described herein are exemplary of a plurality of possible arrangements to provide the same general features, characteristics, and general system operation. Modifications and alterations will occur to others upon a reading and understanding of the preceding detailed description. It is intended that the invention be construed as including all such modifications and alterations.

CLAIMS:

What is claimed is:

1. A fixation guide device for positioning and inserting an intramedullary nail,
5 comprising:
 - a frame including a first end and a second end;
 - a compression device removably coupled to the first end of the frame; and
 - the intramedullary nail secured to a nail attachment apparatus of the frame.
- 10 2. The fixation guide device of claim 1, wherein the frame comprises:
 - at least one drill hole; and
 - a first arm, comprising:
 - 15 a first opening;
 - a second opening below and spaced apart from the first opening; and
 - the nail attachment apparatus extending away from the first arm and aligned
with the second opening.
3. The fixation guide device of claim 2, wherein the nail attachment apparatus
comprises:
20
 - a first nail attachment segment extending away from the first arm a first distance; and
 - a second nail attachment segment extending away from the first arm a second
distance, wherein the first distance is greater than the second distance.
4. The fixation guide device of claim 2, wherein the compression device comprises:
25
 - a compression member;
 - a knob; and
 - a bolt with a first end and a second end, wherein the bolt rotatably engages the
compression member at the first end and is secured to the knob at the second end, and the
bolt extends through and rotatably couples to the first opening in the first arm of the frame.
- 30 5. The fixation guide device of claim 4, wherein the compression member comprises:
 - a base with a top end and a bottom end;
 - a protrusion positioned near the bottom end;
 - a first opening positioned near the top end; and

a second opening positioned near the bottom end and extending through the base and the protrusion, wherein the second opening slidingly couples to the nail attachment apparatus of the first arm of the frame.

- 5 6. The fixation guide device of claim 5, wherein the protrusion of the compression member is angled.
7. The fixation guide device of claim 2, wherein the frame, further comprises:
a second arm positioned generally between the first end and the second end of the
10 frame, and wherein the first arm is positioned at the first end of the frame.
8. The fixation guide device of claim 7, wherein the at least one drill hole of the frame comprises:
a first drill hole near the first end of the frame;
15 a second drill hole positioned between the first end and the second end of the frame;
a third drill hole positioned near the first end of the frame; and
a fourth drill hole positioned on the second arm.
9. The fixation guide device of claim 2, wherein the frame, further comprises:
20 an outward extending wing at the first end of the frame, and wherein the first arm is positioned at the second end of the frame.
10. The fixation guide device of claim 2, further comprising
at least one drill sleeve removably inserted into the at least one drill hole of the frame.
25
11. The fixation guide device of claim 3, wherein the intramedullary nail comprises:
a body with a first end and a second end;
at least two openings positioned oblique to a longitudinal axis of the body between the
first end and the second end; and
30 a fastening end with at least one opening extending from the second end into the body along the longitudinal axis of the body.
12. The fixation guide device of claim 11, wherein the at least two openings comprises:
three first openings; and
35 a second elongated opening.

13. The fixation guide device of claim 11, wherein the fastening end further comprises:
a first fastening segment extending away from the body a first distance and shaped to engage the second nail attachment segment; and
a second fastening segment extending away from the body a second distance and
5 shaped to engage the first nail attachment segment, wherein the first distance is greater than the second distance.
14. The fixation guide device of claim 1, wherein the intramedullary nail is inserted through a joint and the joint is selected from a group consisting of a tarsal-metatarsal joint
10 and a metatarsal-phalangeal joint.
15. An intramedullary nail, comprising:
a body with a first end and a second end, the body comprising:
a fastening end at the first end of the body and with an insertion opening
15 extending from the first end into the body along a longitudinal axis of the body;
a closed end at the second end of the body; and
at least two openings positioned oblique to the longitudinal axis of the body between the first end and the second end of the body.
- 20 16. The intramedullary nail of claim 15, wherein the fastening end, further comprises:
a first fastening segment extending away from the body a first distance;
a second fastening segment extending away from the body a second distance, wherein the first distance is greater than the second distance; and
an engagement opening extending from the first end through the body to an exterior
25 surface and wherein a portion of the engagement opening overlaps with the insertion opening.
17. The intramedullary nail of claim 15, wherein the at least two openings comprises four openings extending through the body on independent planes and angularly spaced apart.
- 30 18. The intramedullary nail of claim 17, wherein the at least two openings comprises:
three first openings; and
a second elongated opening.
19. The intramedullary nail of claim 18, wherein the insertion opening of the fastening
35 end engages the second elongated opening.

20. The intramedullary nail of claim 19, further comprising:
a plurality of fasteners, wherein two fasteners of the plurality of fasteners engage the
at least two openings of the body.
- 5 21. The intramedullary nail of claim 20, further comprising:
a cam member sized to engage the insertion opening and the second elongated
opening to translate a fastener of the plurality of fasteners inserted through the second
elongated opening along the second elongated opening.
- 10 22. A compression device for compressing a joint with an implant, comprising:
a compression member;
a knob; and
a bolt secured in the knob and rotatably engaging the compression member.
- 15 23. The compression device of claim 22, wherein the compression member comprises:
a base with a top end and a bottom end;
a protrusion extending away from the base at the bottom end;
a first opening near the top end; and
a second opening extending through the base and the protrusion at the bottom end.
- 20 24. The compression device of claim 23, wherein the knob comprises:
a first opening for receiving the bolt;
a second opening relatively perpendicular to the first opening and extending into the
first opening for receiving a fastener; and
25 a plurality of ridges on an exterior surface of the knob.
25. The compression device of claim 24, wherein the bolt comprises:
a first end with a plurality of threads extending along the first end for engaging the
first opening;
30 a second end with a smooth exterior surface and an opening extending relatively
perpendicular to a longitudinal axis of the bolt for aligning with the second opening of the
knob to receive the fastener to couple the bolt and the knob; and
a stop member positioned between the first end and the second end.
- 35 26. An alignment guide, comprising:

a base member with a first portion and a second portion, wherein the second portion extends out from the first portion in a relatively perpendicular direction and the first portion comprises at least one opening;

5 an alignment member with at least one opening, wherein the alignment member is coupled to the base member and angled relative to the second portion of the base member; and

a fixation guide removably inserted through one of the at least one openings in the first portion of the base member.

10 27. The alignment guide of claim 26, wherein the alignment member is angled between approximately 0 degrees and 25 degrees relative to the second portion of the base member.

28. A method of inserting an intramedullary nail into two bones for fixation of the two bones, comprising:

15 creating an incision near the two bones;

preparing the two bones for fixation;

securing an alignment guide to the two bones to position a guidewire across the two bones;

20 drilling over the guidewire to create a cavity for the intramedullary nail that passes through the two bones, wherein the intramedullary nail includes a securing screw hole at a first end of the intramedullary nail and at least two peg holes;

obtaining a fixation guide device, wherein the fixation guide device includes a frame with at least two drill holes and a compression device;

25 attaching the intramedullary nail to the compression device of the fixation guide device;

inserting the intramedullary nail into the cavity;

inserting a drill sleeve into a first drill hole at a second end of the fixation guide device and drilling a first opening that aligns with a first peg hole in the second end of the intramedullary nail;

30 inserting a first peg into the first opening and through the first peg hole;

using the first peg and compression device to compress the two bones;

inserting the drill sleeve into a second drill hole at a first end of the fixation guide device and drilling a second opening that mates with a second peg hole in the first end of the intramedullary nail;

inserting a second peg into the second opening and through the second peg hole to secure the two bones in compression;

detaching the intramedullary nail from the fixation guide and removing the fixation guide device;

5 inserting a locking screw into the securing screw hole; and
closing the incision.

29. The method of claim 28, further comprising:

10 inserting the drill sleeve into a third drill hole at the second end of the fixation guide device and drilling a third opening that aligns with a third peg hole;

inserting a third peg into the third opening and through the third peg hole to secure the two bones in compression; and

verifying the stability and position using fluoroscopy.

15 30. The method of claim 29, further comprising:

inserting the drill sleeve into a fourth drill hole at the first end of the fixation guide device and drilling a fourth opening that aligns with a fourth peg hole;

inserting a fourth peg into the fourth opening and through the fourth peg hole to secure the two bones in compression; and

20 verifying the stability and position using fluoroscopy.

31. The method of claim 30, wherein the two bones are a joint and the joint is selected from a tarsal-metatarsal joint and a metatarsal-phalangeal joint.

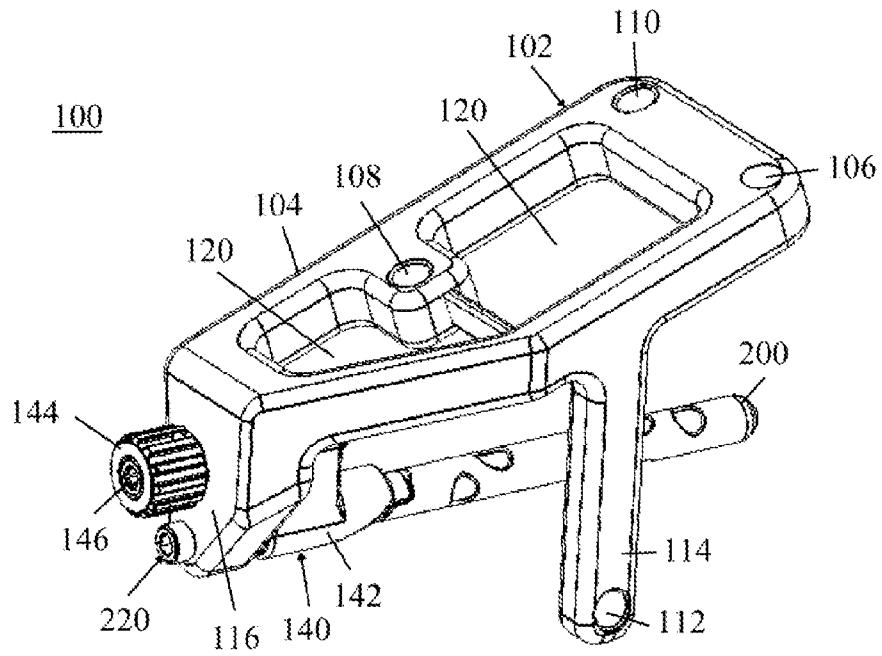

FIG. 1

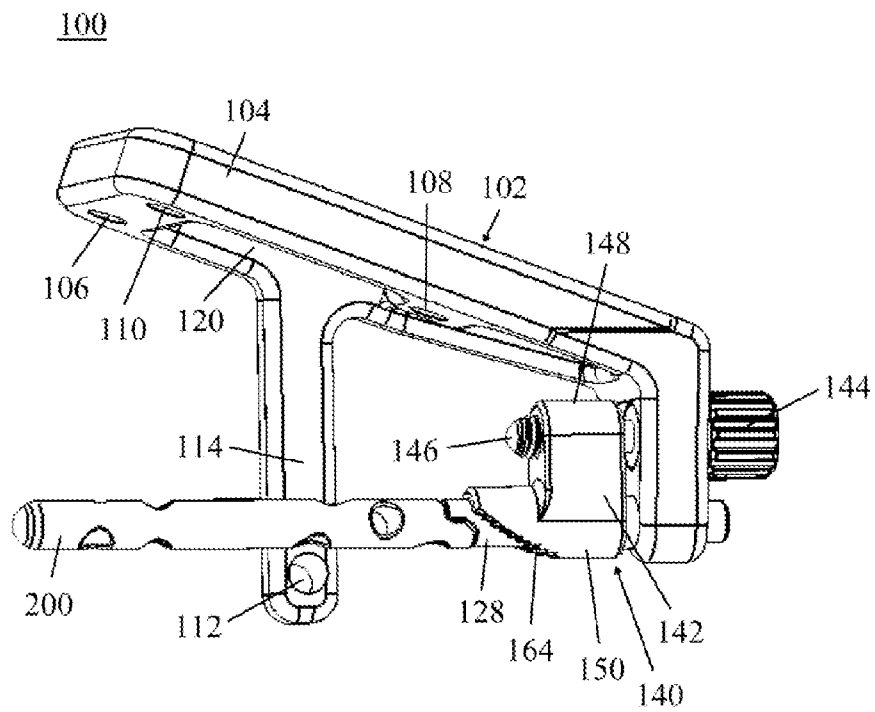

FIG. 2

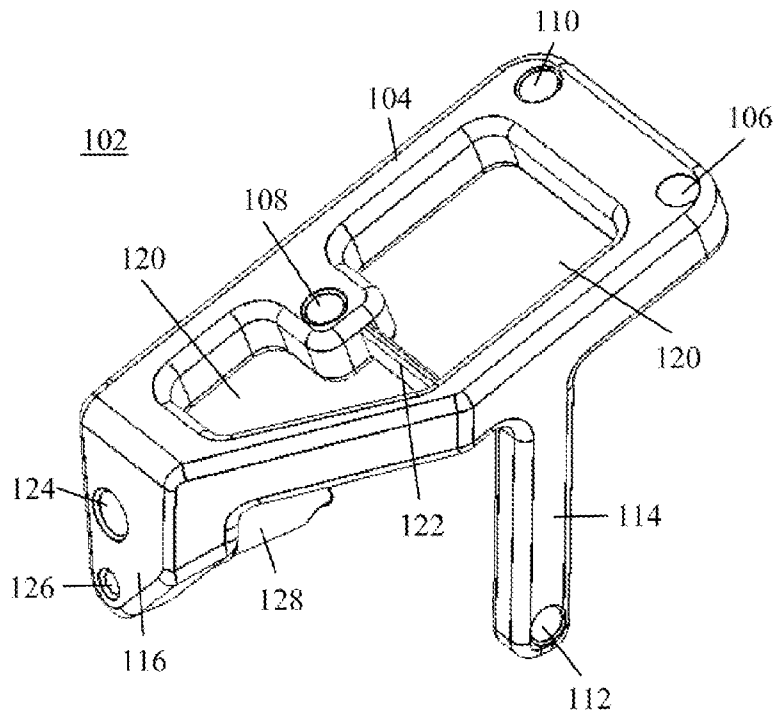

FIG. 3

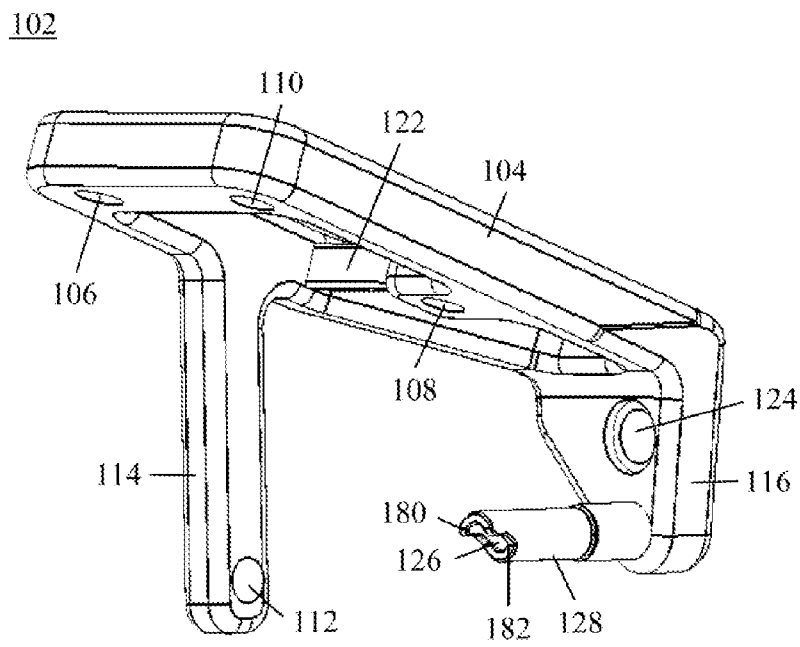

FIG. 4

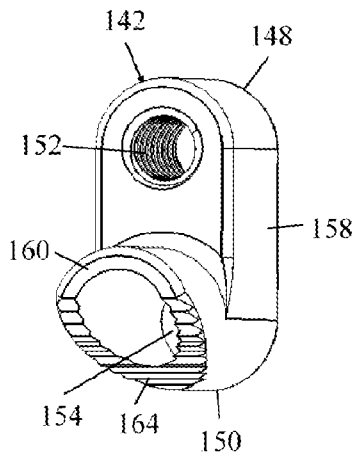

FIG. 5

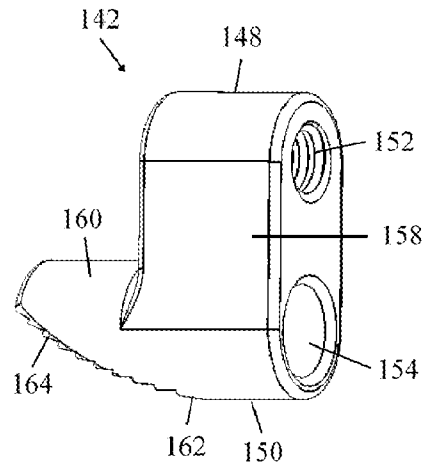

FIG. 6

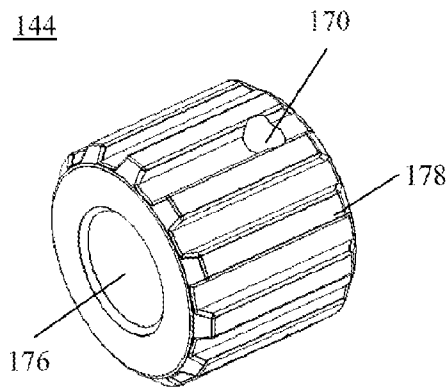

FIG. 7

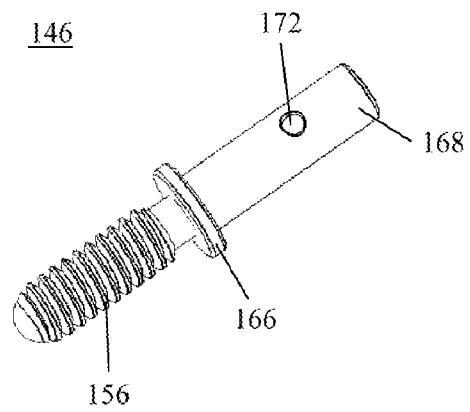

FIG. 8

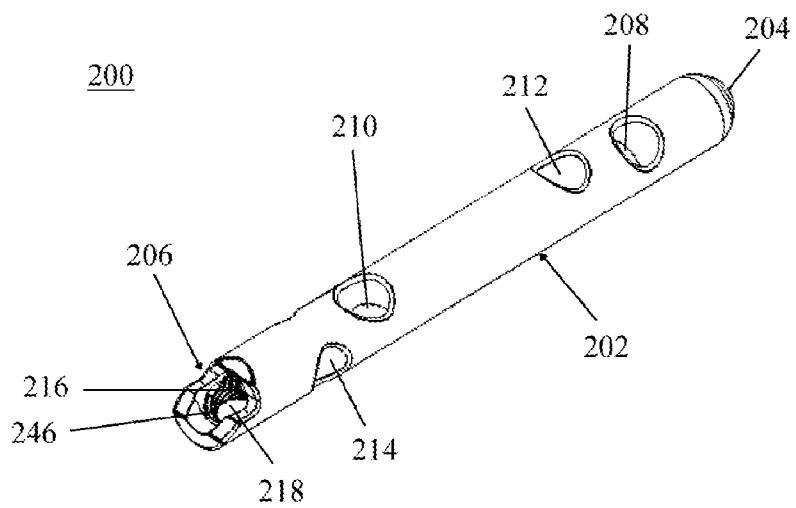

FIG. 9

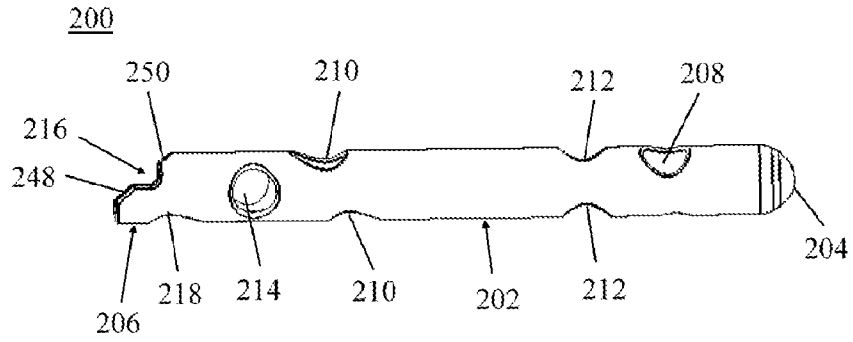

FIG. 10

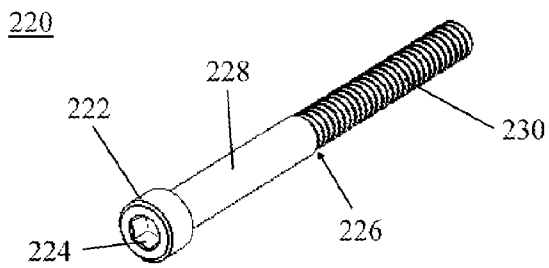

FIG. 11

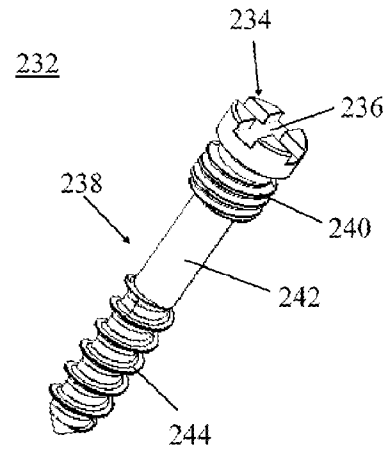

FIG. 12

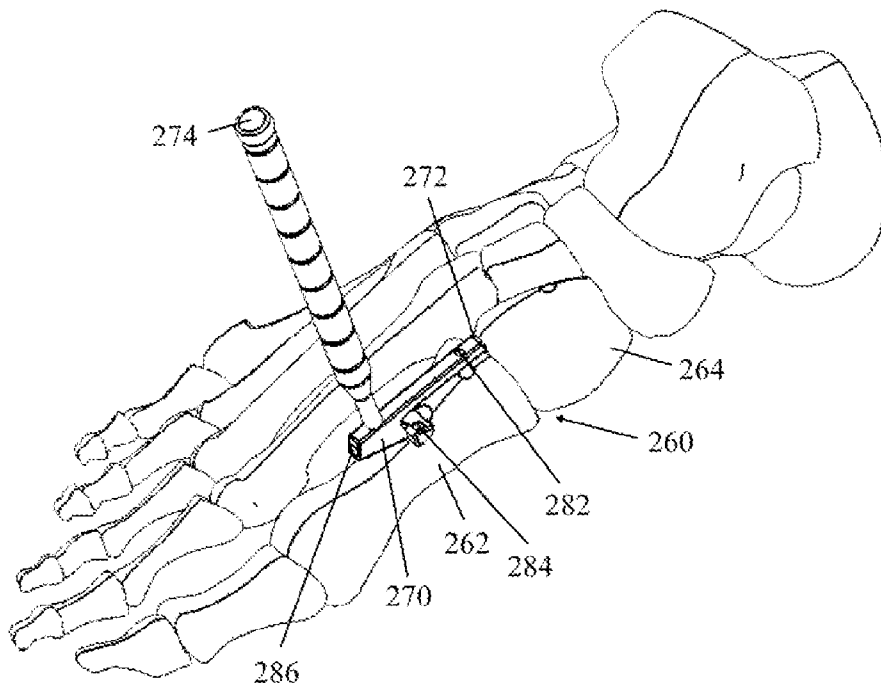

FIG. 13

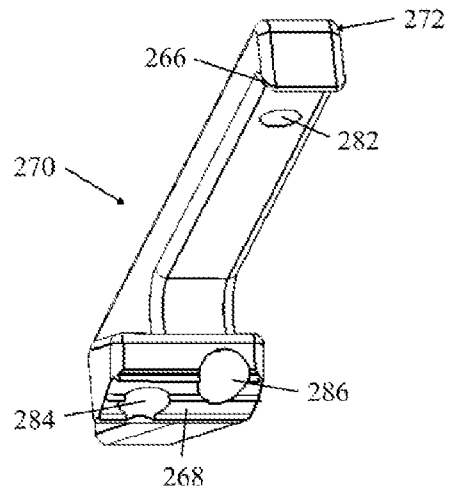

FIG. 14

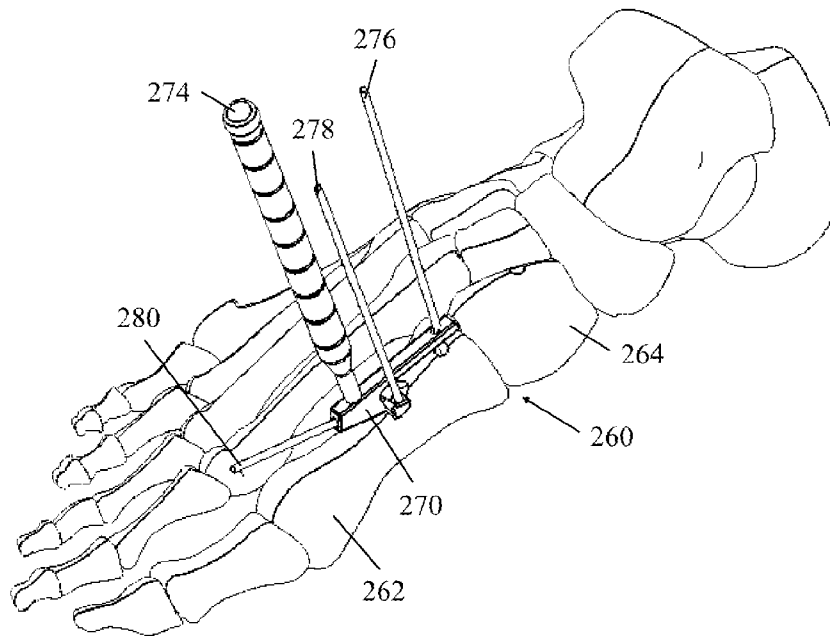

FIG. 15

6/22

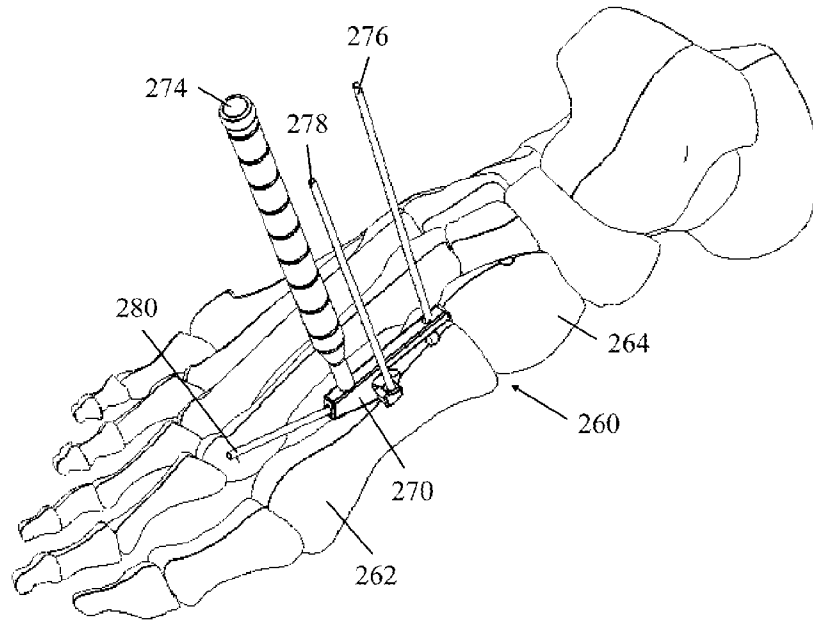

FIG. 16

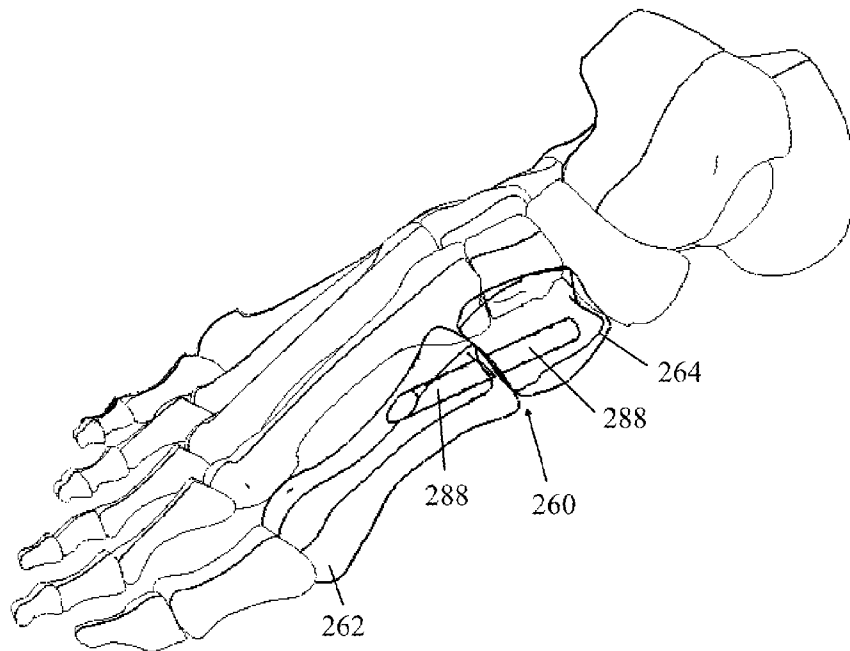

FIG. 17

7/22

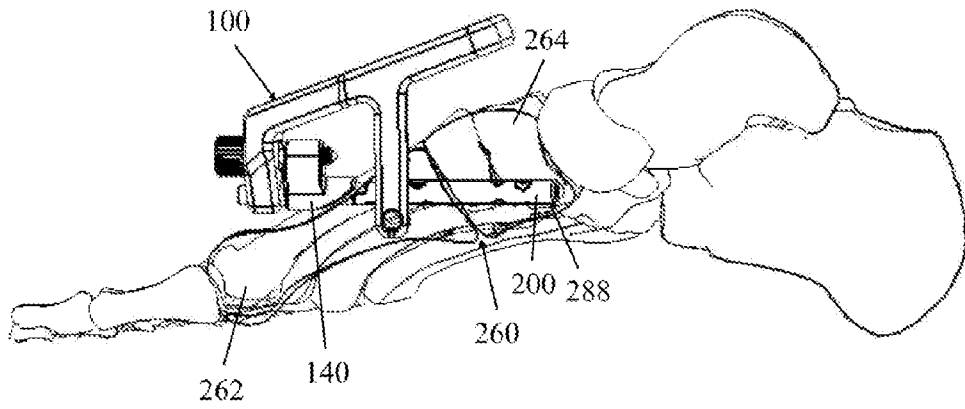

FIG. 18

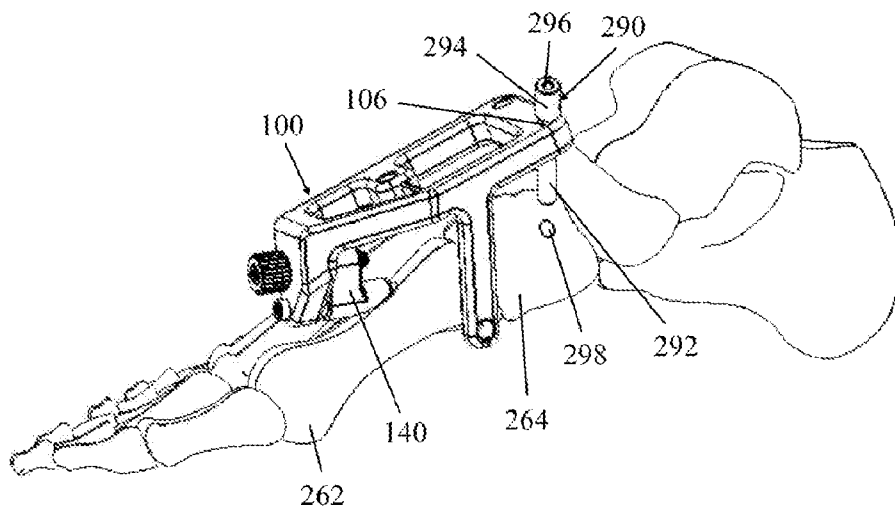

FIG. 19

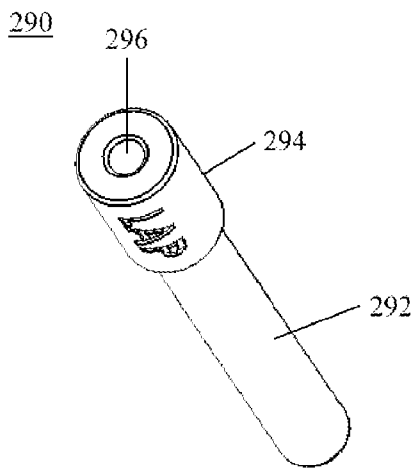

FIG. 20

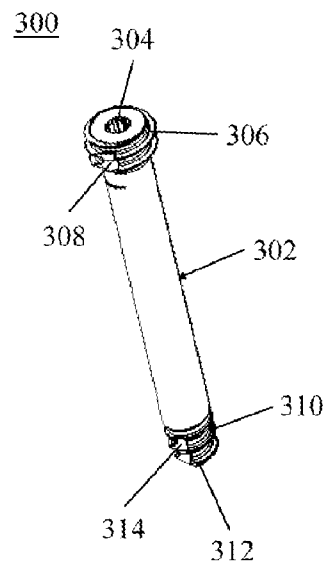

FIG. 21

8/22

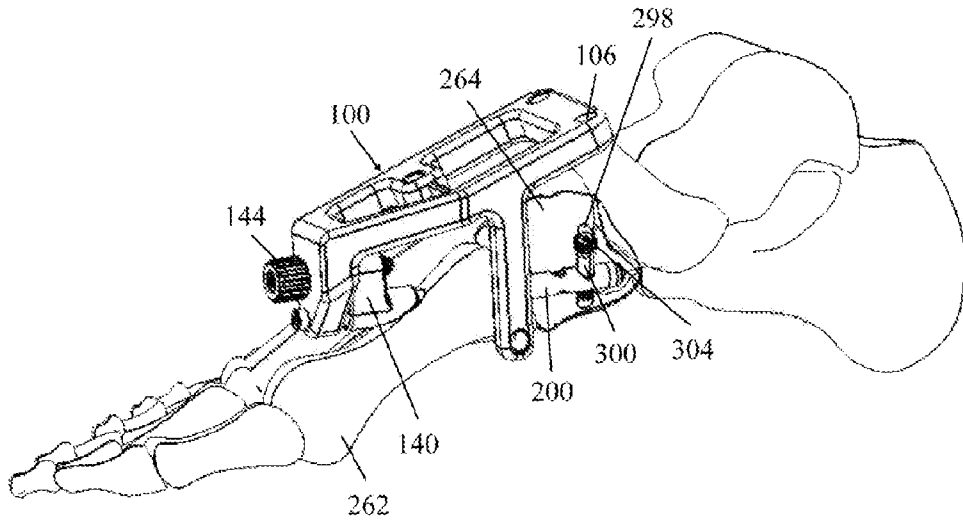

FIG. 22

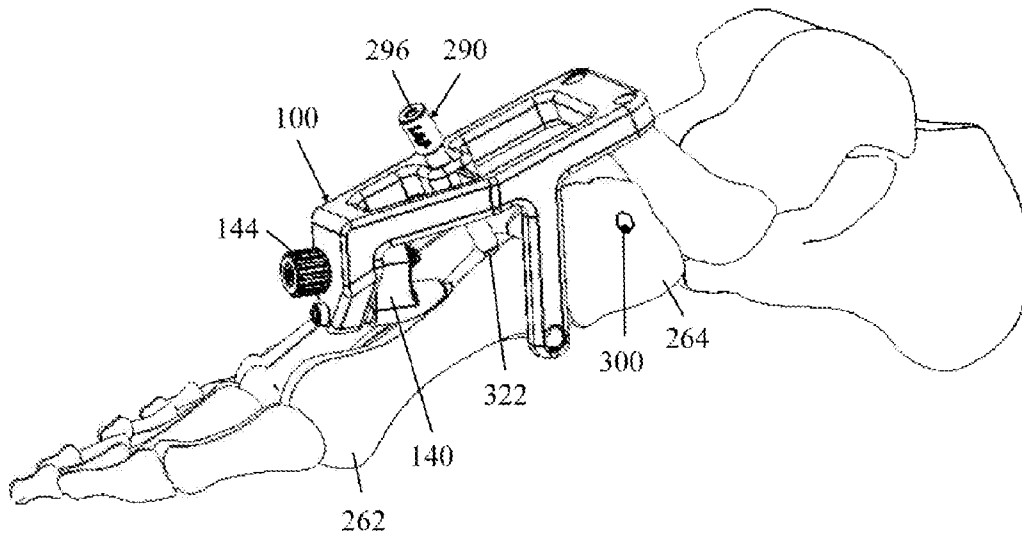

FIG. 23

9/22

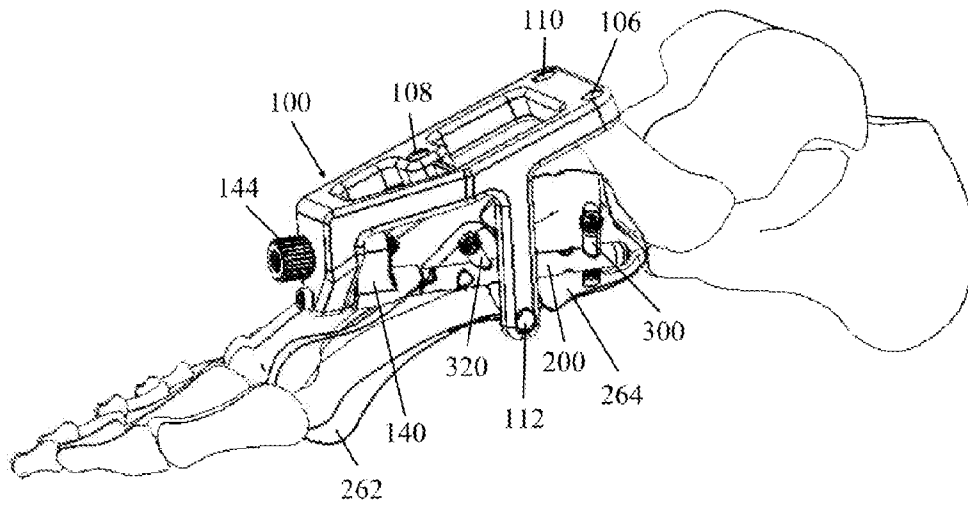

FIG. 24

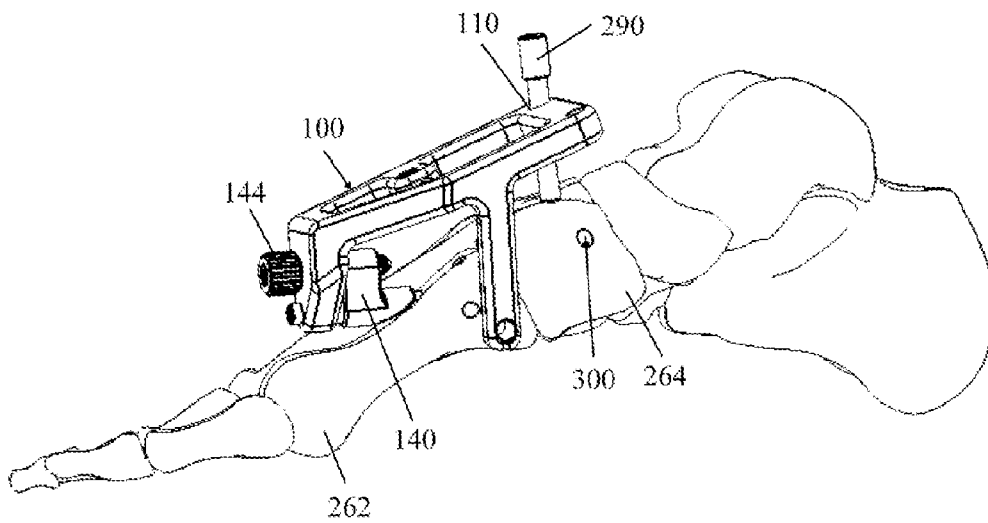

FIG. 25

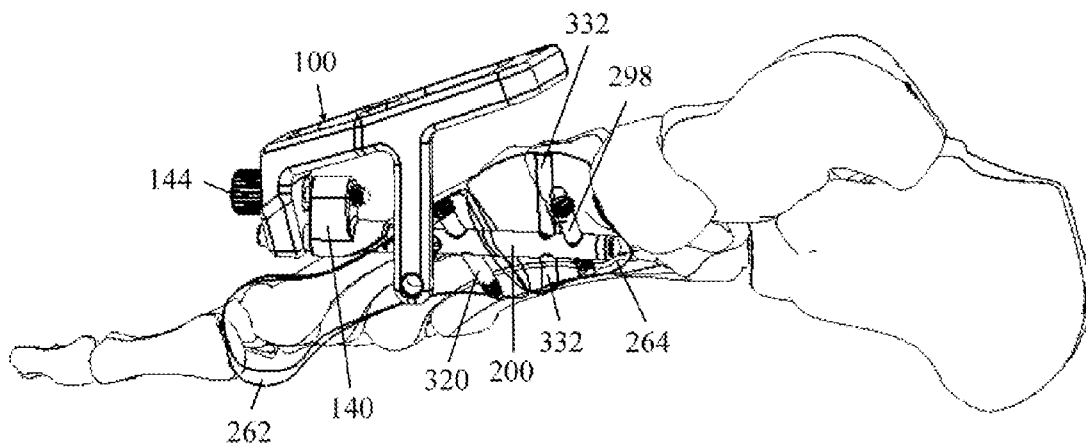

FIG. 26

10/22

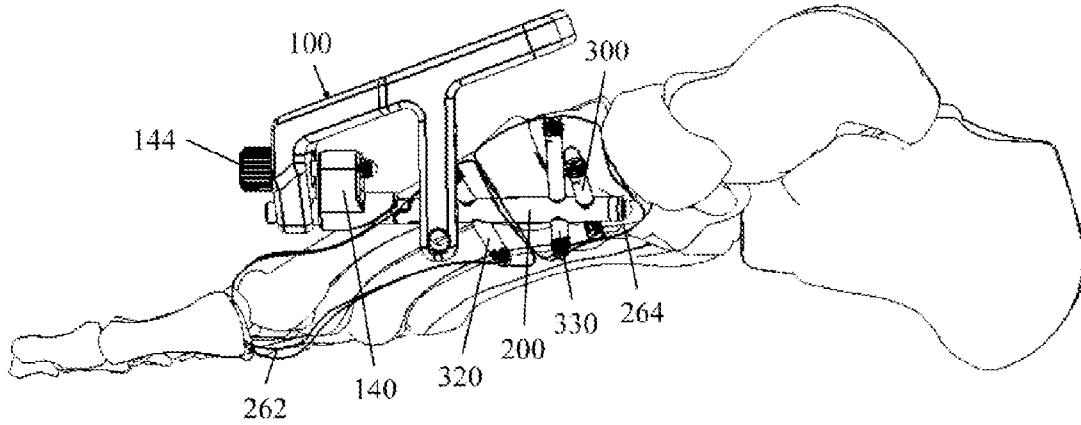

FIG. 27

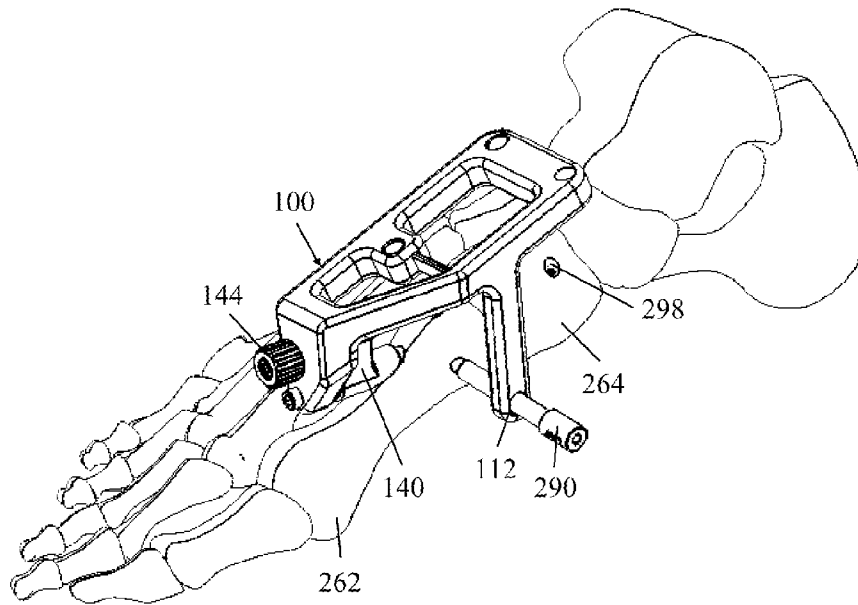

FIG. 28

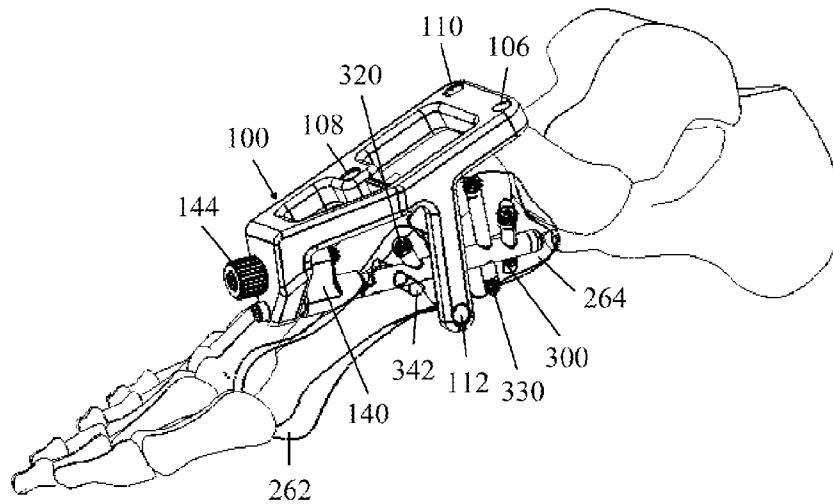

FIG. 29

11/22

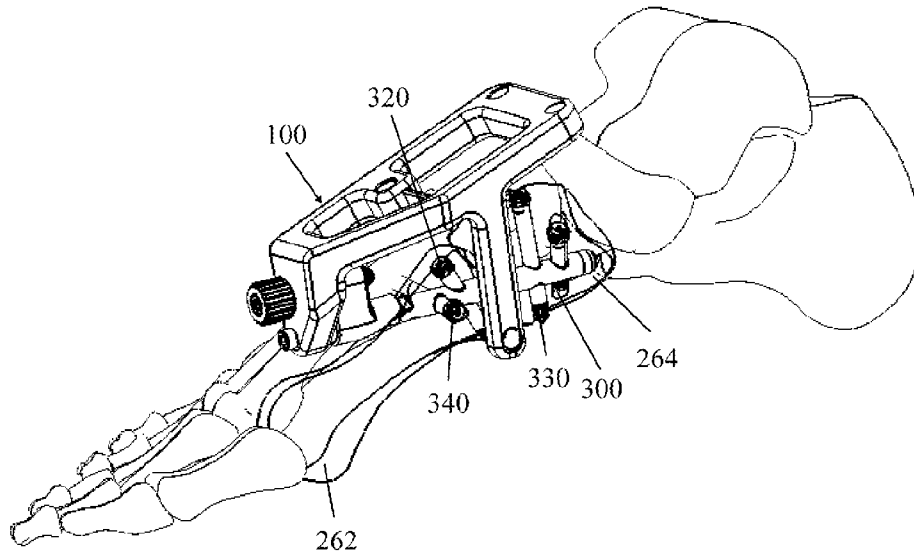

FIG. 30

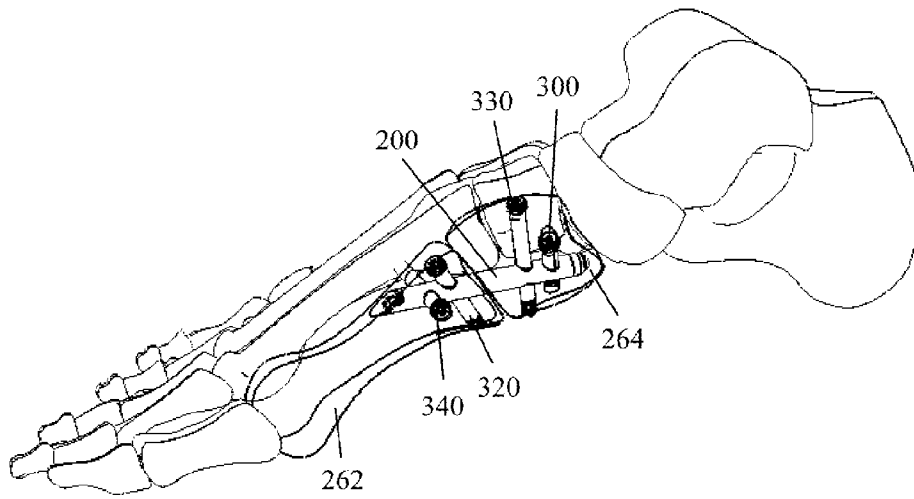

FIG. 31

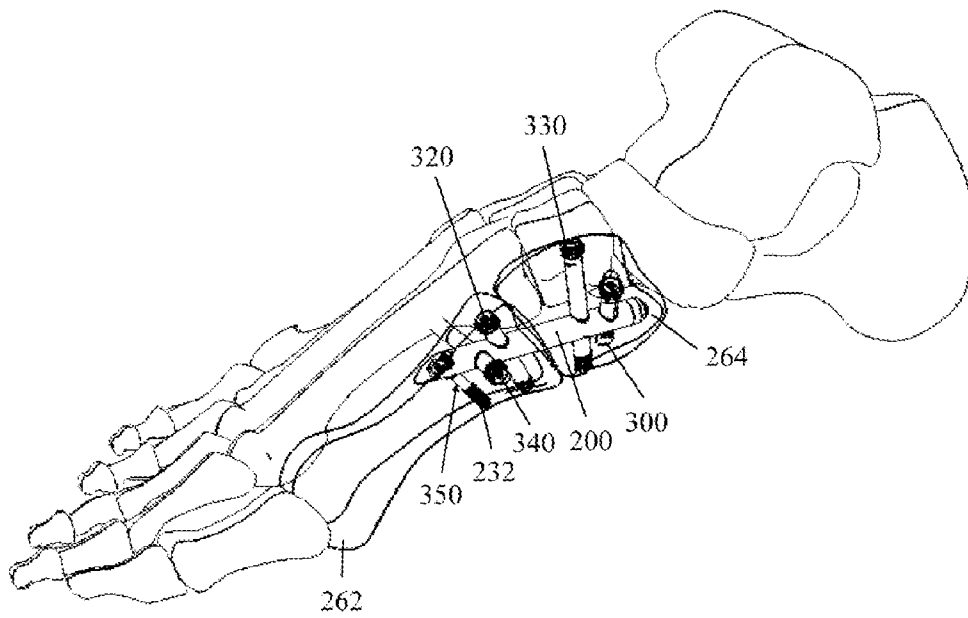

FIG. 32

12/22

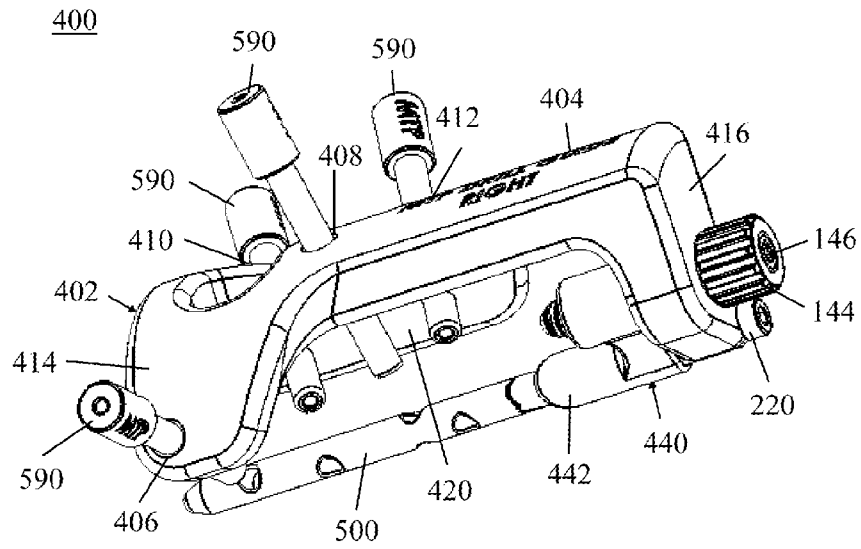

FIG. 33

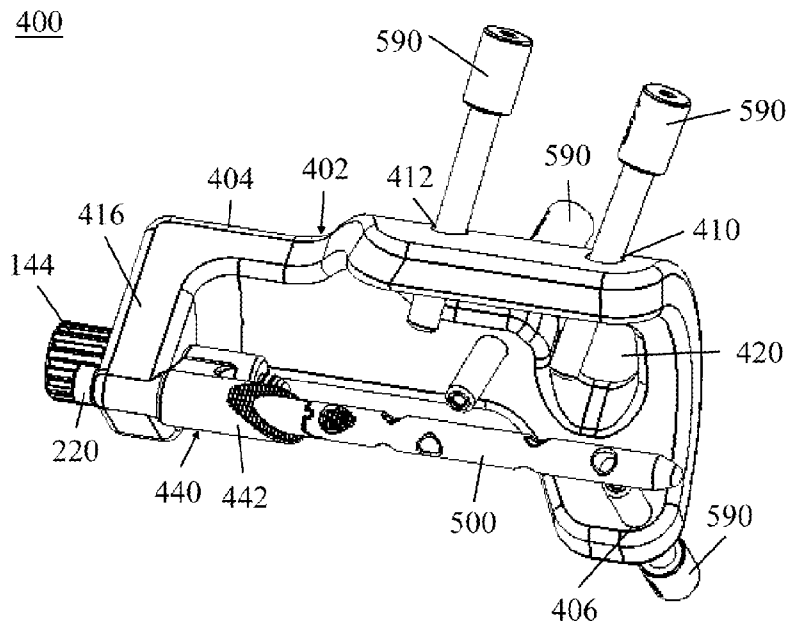

FIG. 34

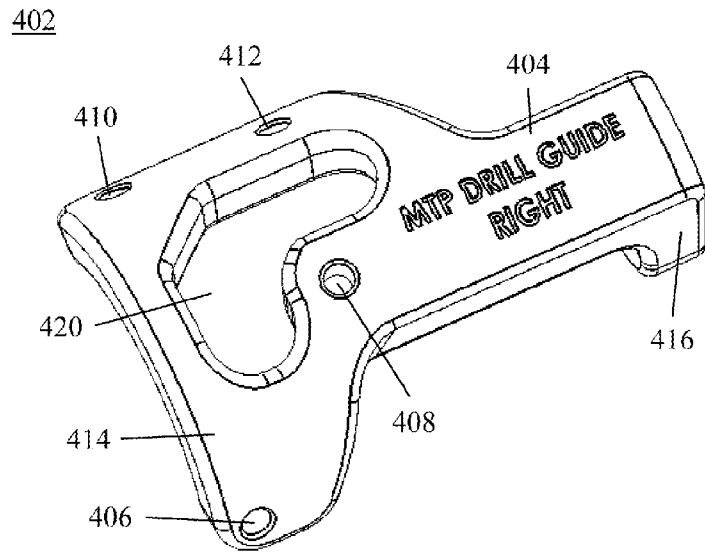

FIG. 35

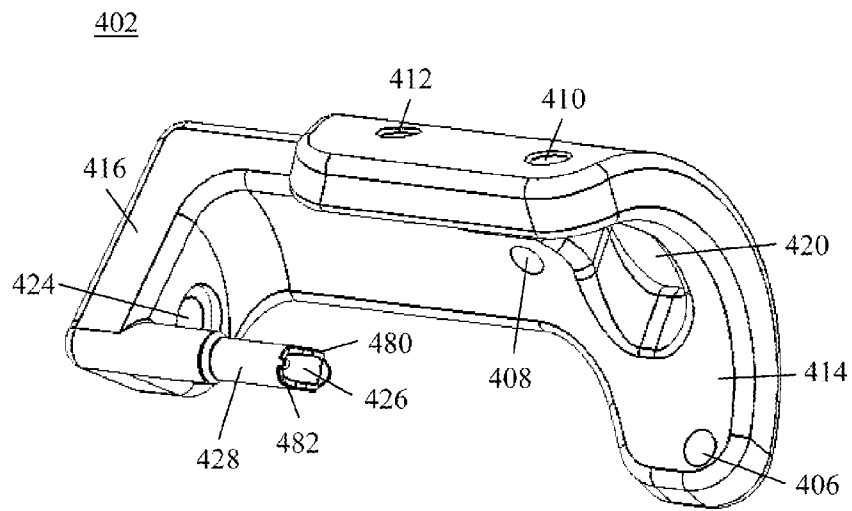

FIG. 36

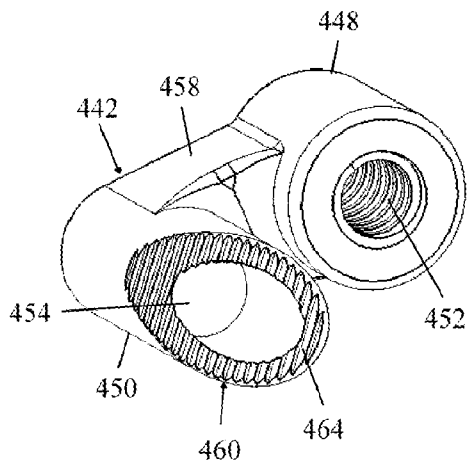

FIG. 37

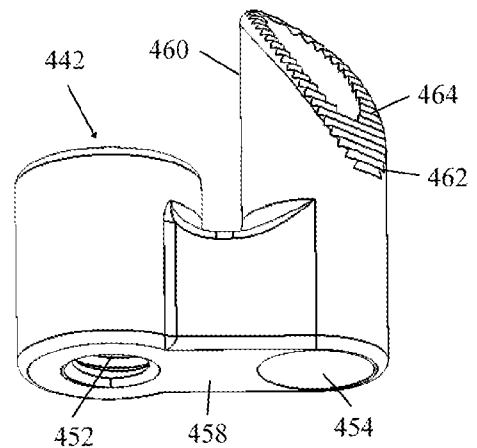

FIG. 38

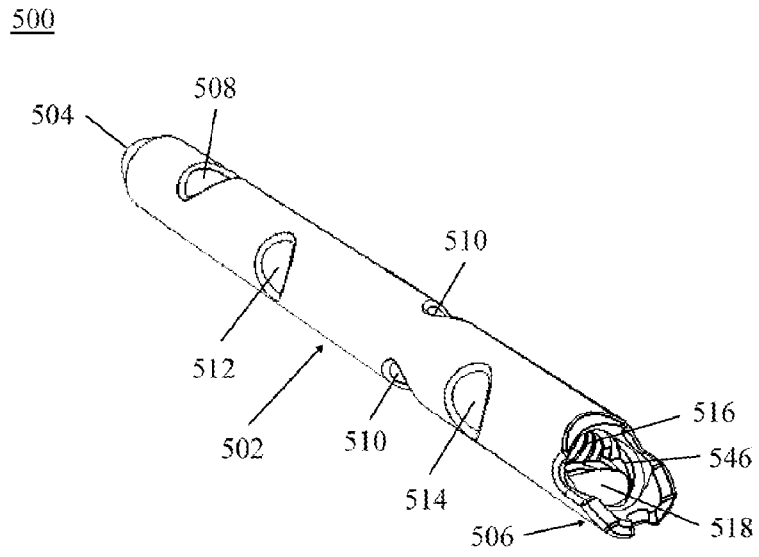

FIG. 39

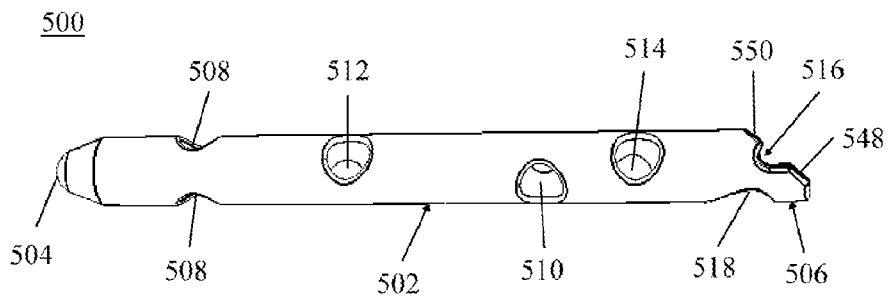

FIG. 40

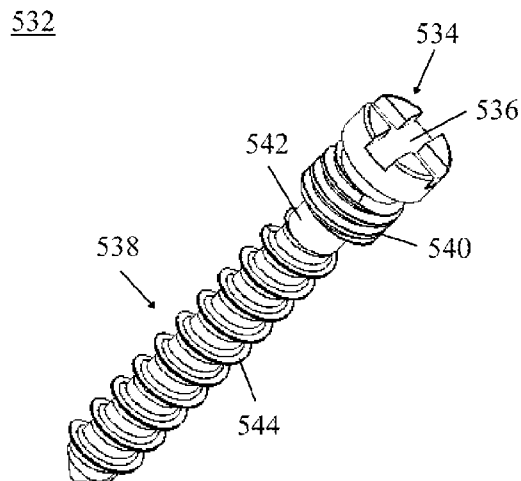
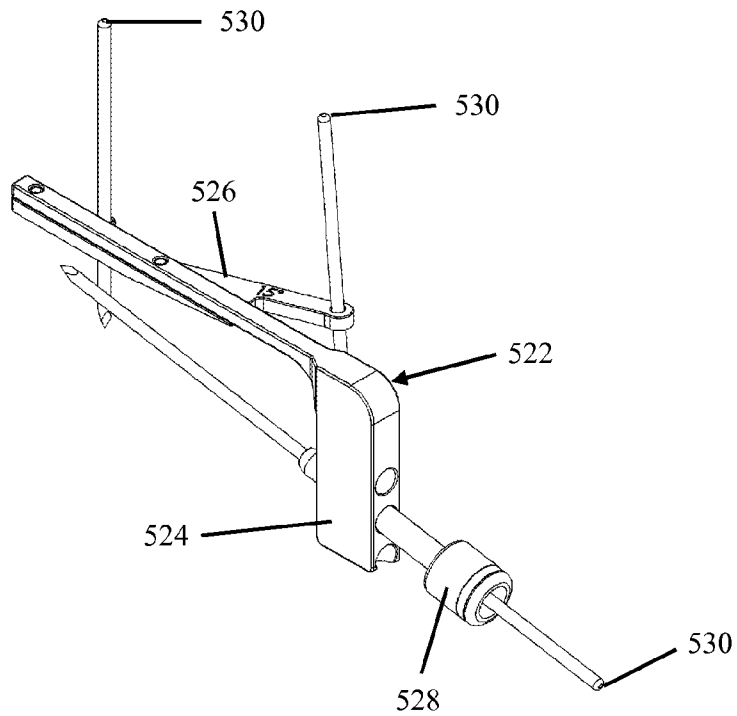
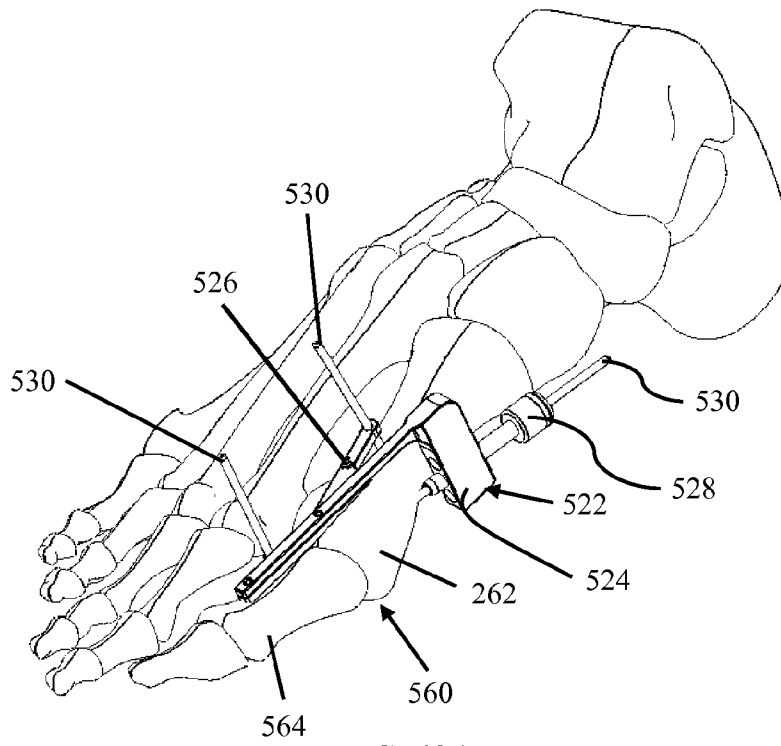

FIG. 41



16/22

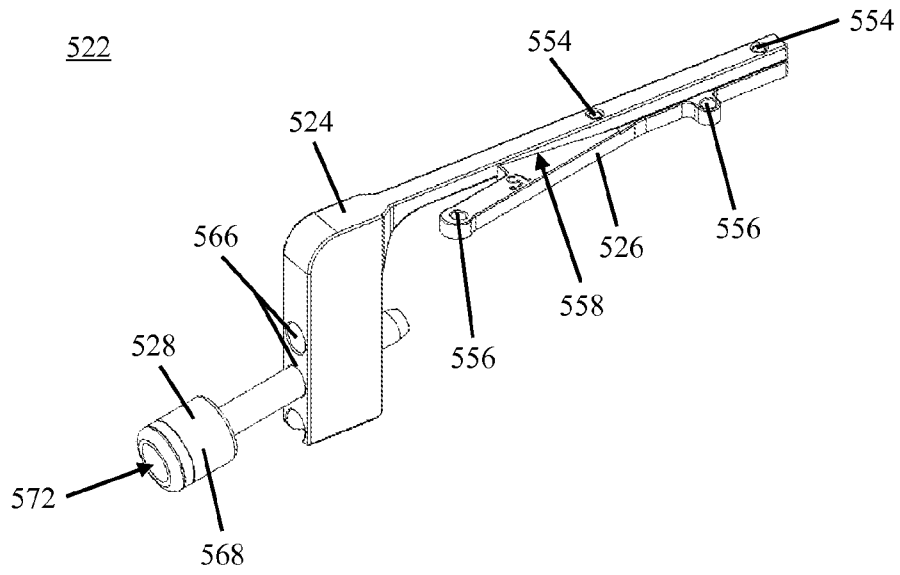

FIG. 42C

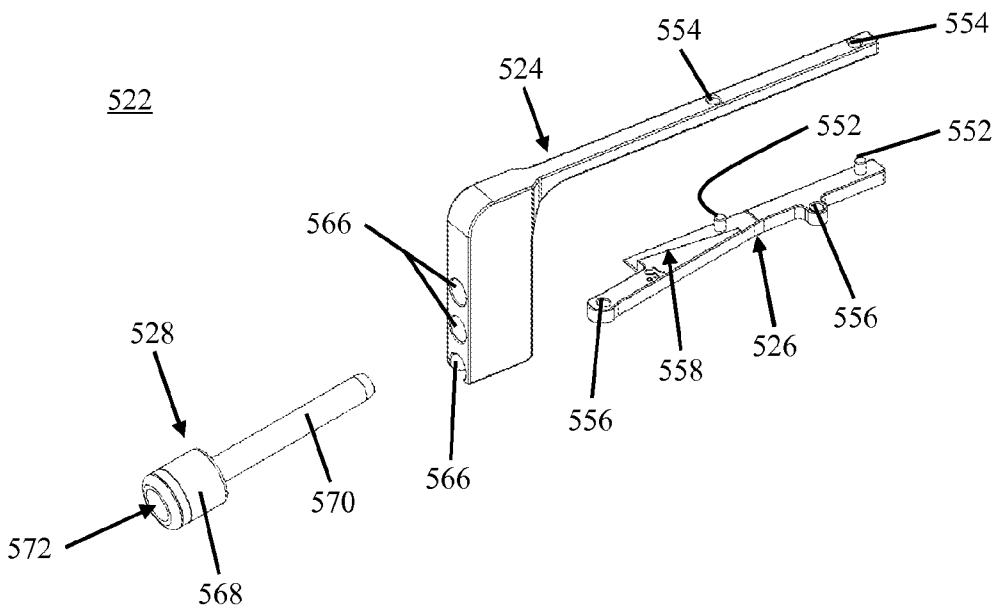

FIG. 42D

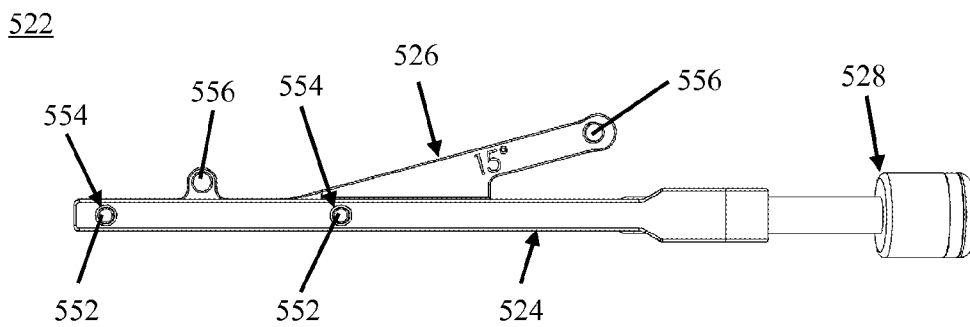

FIG. 42E

17/22

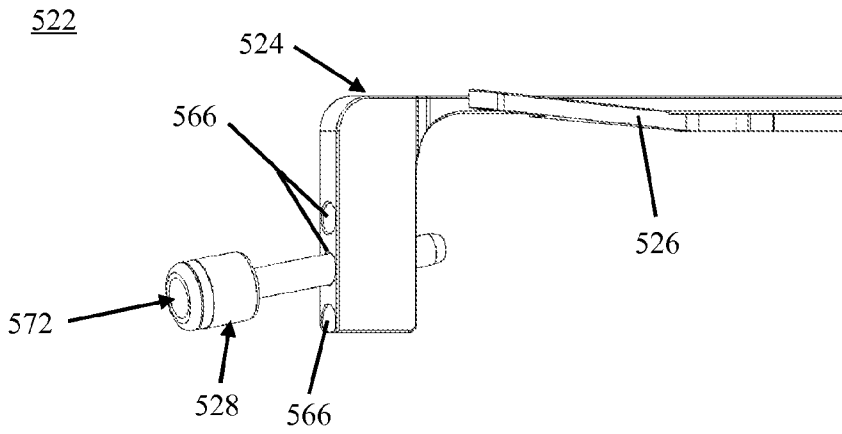

FIG. 42F

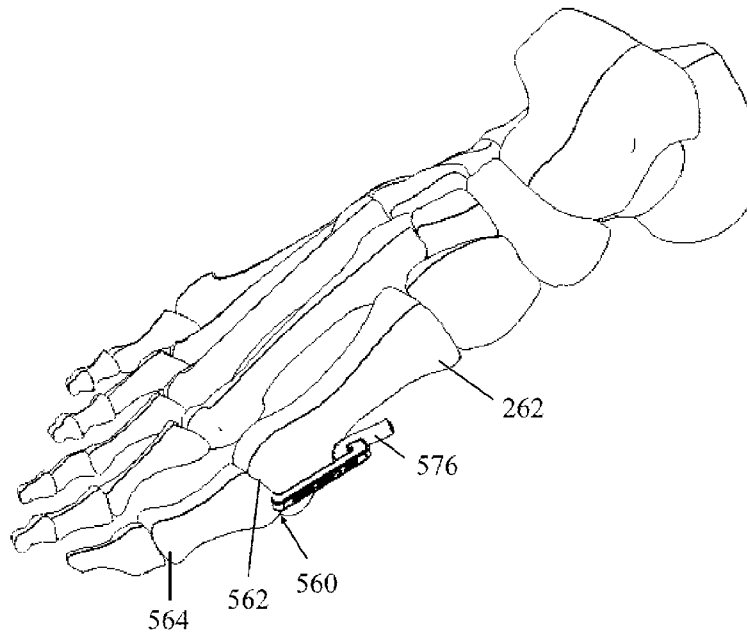

FIG. 43A

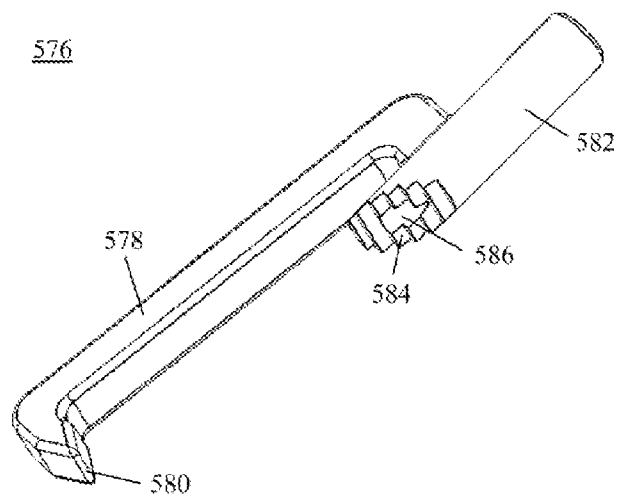

FIG. 43B

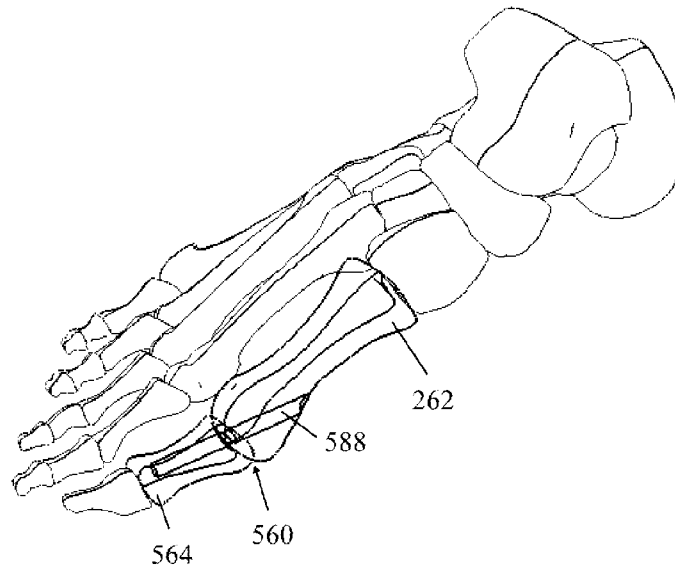

FIG. 44

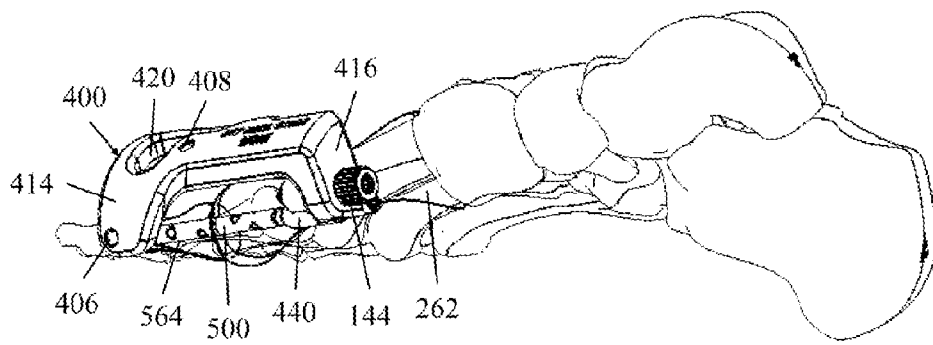

FIG. 45

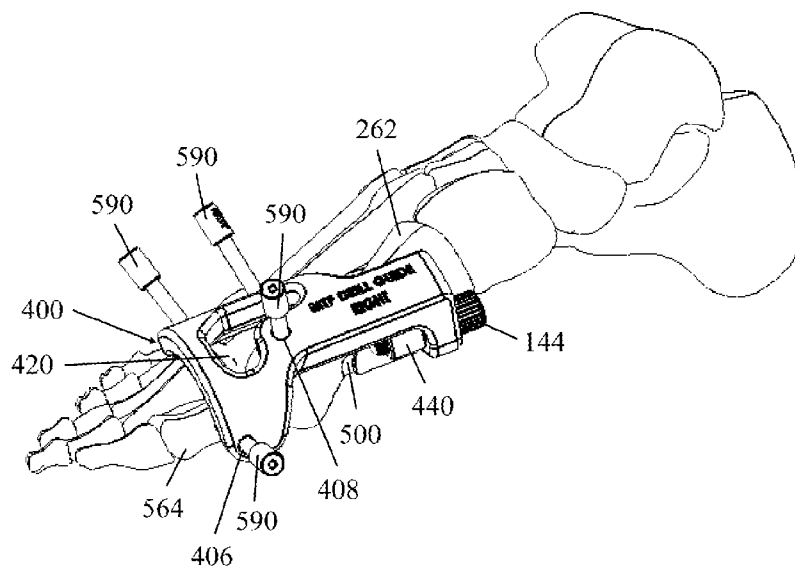

FIG. 46

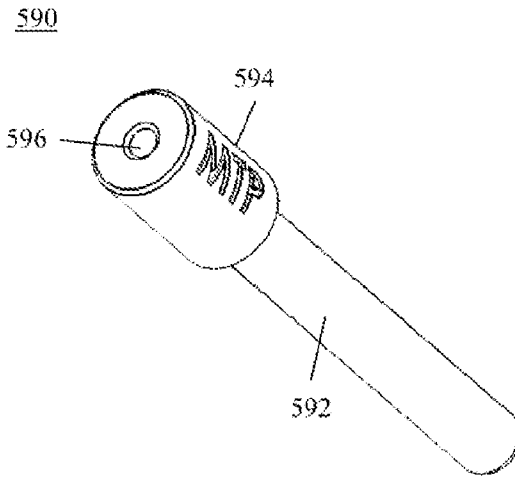

FIG. 47

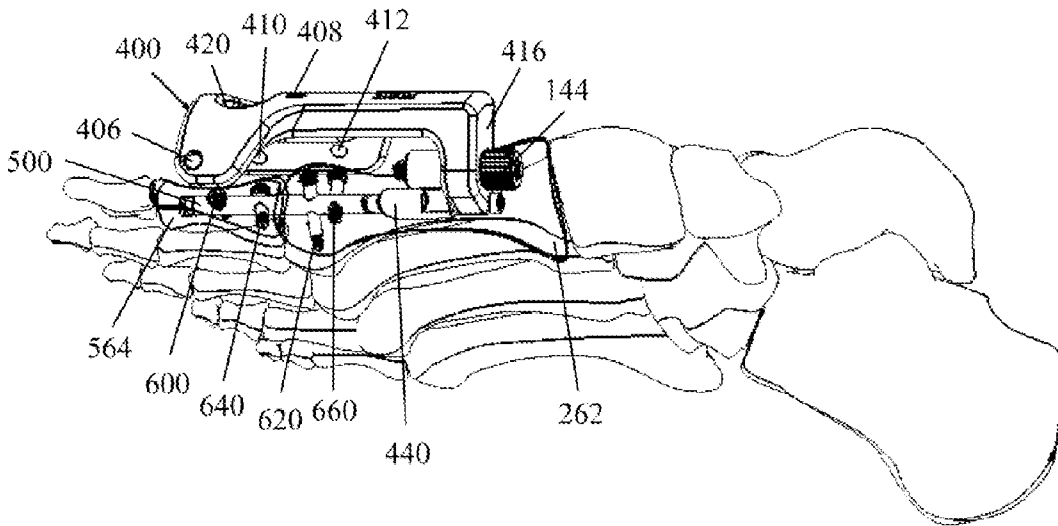

FIG. 48

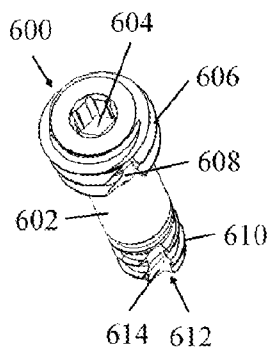

FIG. 49

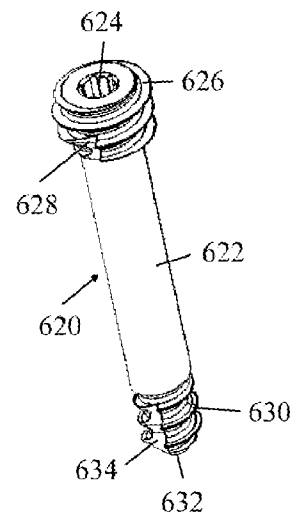

FIG. 50

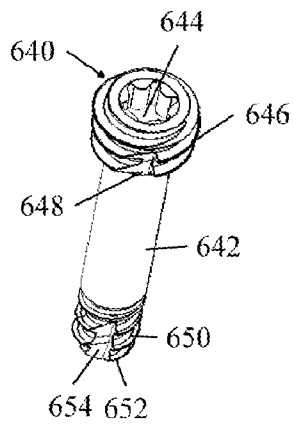

FIG. 51

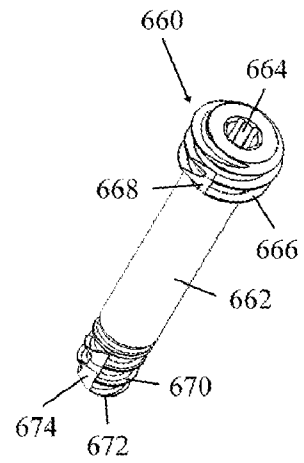

FIG. 52

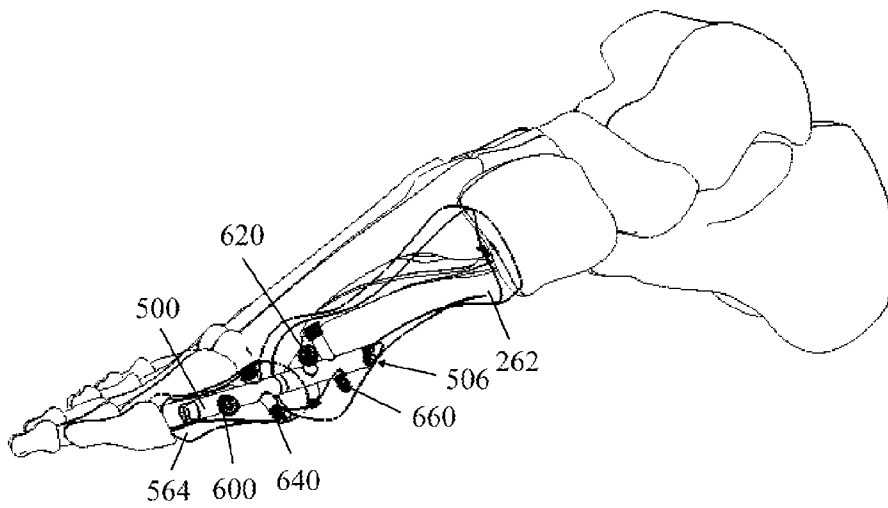

FIG. 53

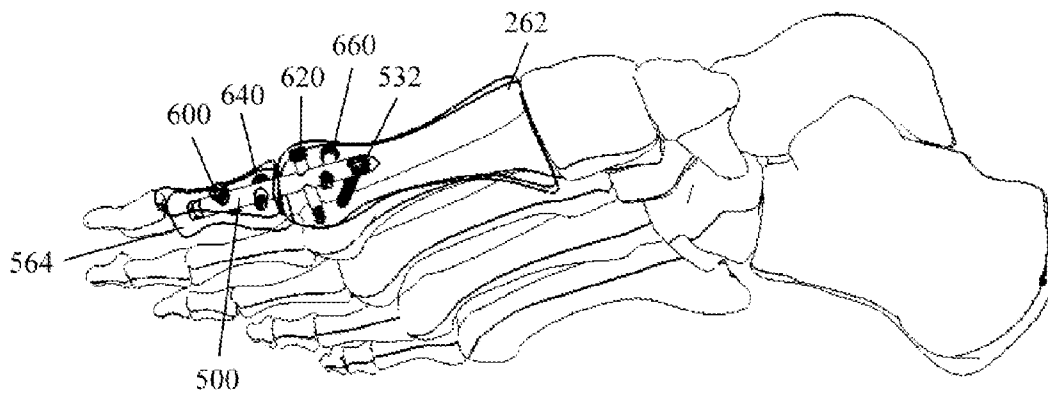

FIG. 54

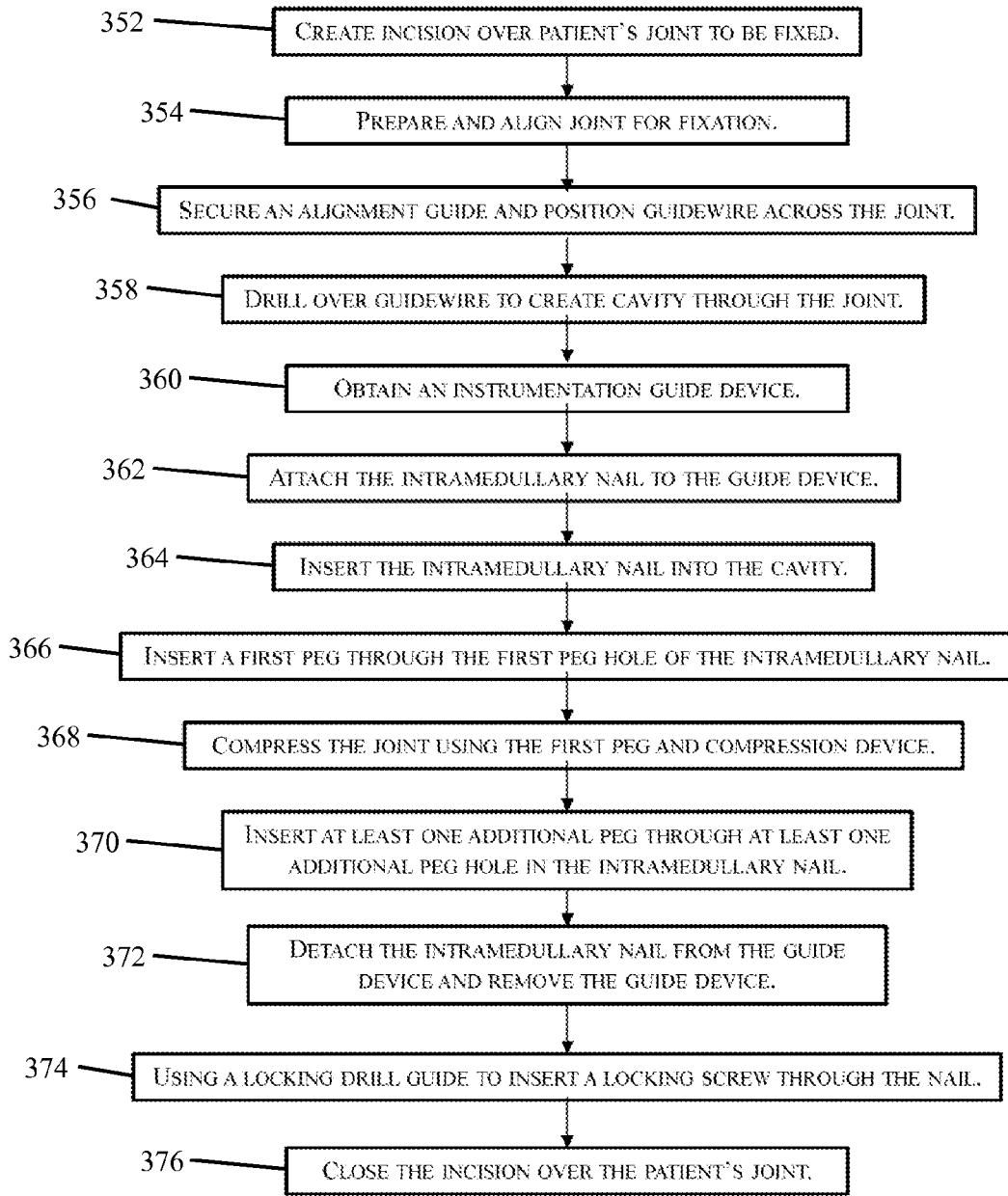

FIG. 55

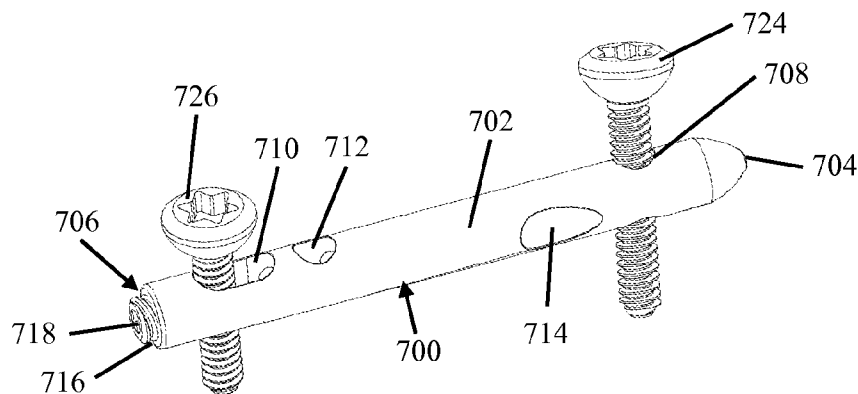

FIG. 56

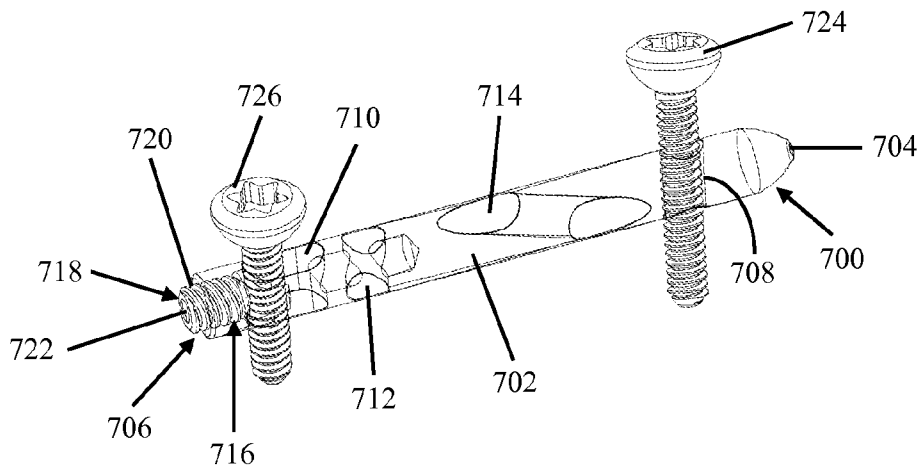

FIG. 57

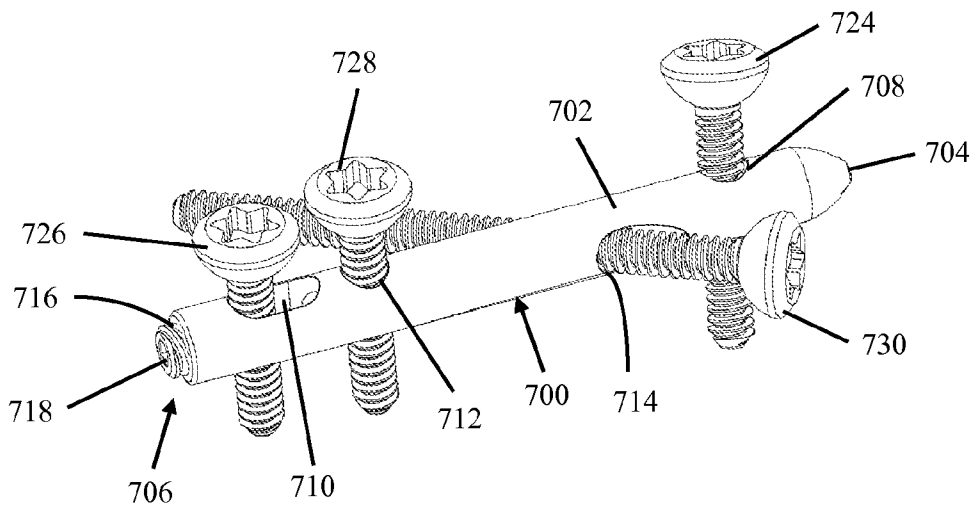

FIG. 58

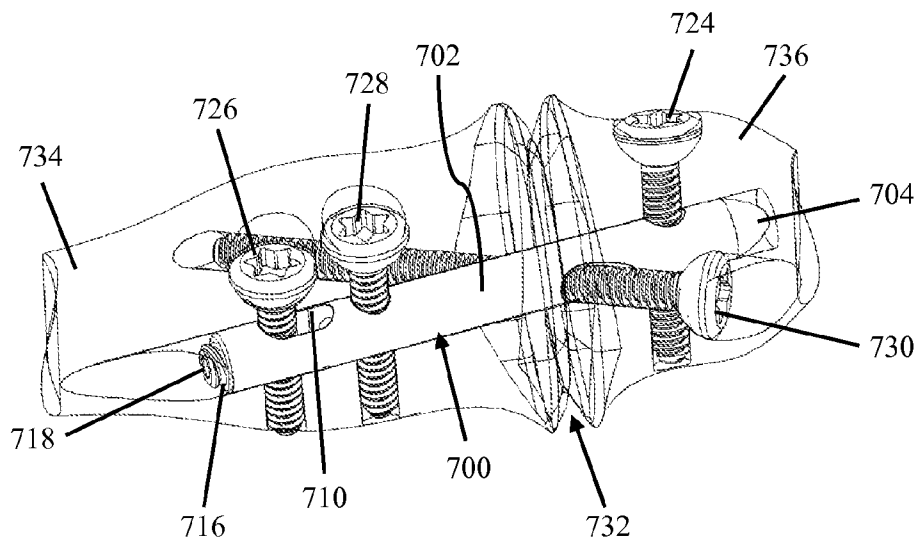

FIG. 59