

VALVE

FIELD OF THE INVENTION

[0001] The present invention relates to a valve, and particularly to a solution providing a working and easy-to-use valve.

DESCRIPTION OF PRIOR ART

[0002] From the prior art, a valve is known which comprises a cylindrical housing whose wall has an opening for forming a connection between the housing and the flow channel and which is provided with a cylindrically shaped closing member. In this known solution, the cylindrical closing member is dimensioned in such a way that its diameter is greater than the inner diameter of the housing. Thus, when installed in place, the closing member arranged in the housing is pressed against the wall of the housing. However, to achieve a working and easy-to-use valve, this kind of closing member - housing combination that remains in a significant strain state is not a good solution.

SUMMARY OF THE INVENTION

[0003] An object of this invention is to solve the above problem and to provide a solution with which a working and easy-to-use valve can be obtained. This object is achieved with a valve according to claim 1.

[0004] The invention utilizes a closing member having a flexible sector and an open sector which enable, in cooperation, deformation of the closing member without significant force, if required. When such a solution utilizes a guiding sector that positions the closing member relative to the housing in order to place the closing sector at the precisely correct point, a structure is obtained that is capable of closing the flow channel with sufficient tightness and that has no significant strain states between the valve parts. The result is thus a working and easy-to-use valve.

[0005] Preferred embodiments of the valve according to the invention are disclosed in the dependent claims.

BRIEF DESCRIPTION OF THE FIGURES

[0006] In the following, the invention will be described in greater detail by way of example, referring to the attached figures, of which:

Figure 1 illustrates an embodiment of the valve according to the invention;

Figures 2 and 3 illustrate a housing used in the valve of Figure 1;

Figures 4, 5 and 6 illustrate a closing member used in the valve of Figure 1.

DESCRIPTION OF AT LEAST ONE EMBODIMENT

[0007] It is assumed in an exemplary manner that the case of Figure 1 involves a control valve whose cylindrical housing 3 connects a first part 1 of the flow channel and a second part 2 of the flow channel to each other.

[0008] When a closing member 4 arranged in the housing is in a position allowing flow, the flow takes place in the direction of flow illustrated by arrow 5 from the first part 1 of the flow channel, from the open bottom of the cylindrical housing 3 to the housing, and thereafter through an opening in the wall of the housing 3 to the second part 2 of the flow channel. When the closing member 4 is in a position preventing flow, the closing member 4 is pressed, due to the pressure of a flowing medium, against the wall of the housing 3 and the opening in it. This pressing contributes to the tightness.

[0009] The closing member 4 arranged in the housing 3 is rotatable around an axis of rotation 6 via a shaft 7 attached to the closing member 4. The shaft 7 is bearing-mounted on the valve.

[0010] Figures 2 and 3 illustrate the housing 3 used in the valve of Figure 1. In this embodiment, it is assumed in an exemplary manner that the valve utilizes a separate cylindrical sleeve as the housing 3. Figure 2 shows a top view of the housing 3, whereas Figure 3 is a three-dimensional view of the housing 3.

[0011] The sleeve serving as the housing 3 is sealingly attached to the valve by its end surfaces in such a way that a valve cover 8 and the shaft 7 (in Figure 1) close the upper end of the sleeve shown in the figures, while the lower end seen in the figures remains open in the first part 1 of the flow channel.

[0012] The inner surface 9 of the wall of the housing 3 rotates around its mid-axis 6 with radius R. The wall of the cylindrical housing 3 is solid, except for an opening 10 allowing the medium flowing in the housing to

flow to the second part 2 of the flow channel when the closing member is in a position allowing flow.

[0013] Figures 4, 5 and 6 illustrate a closing member 4 used in the valve of Figure 1. In Figures 4 and 5 the closing member is shown three-dimensionally and in Figure 6 from above, seen from the direction of the axis 6.

[0014] The closing member 4 is divided into sectors. Since the housing is cylindrical in the example of the figures, this example also has a closing member with cylindrical sectors. In this embodiment, the closing member 4 comprises a sector 11 covering the flow opening, a flexible sector 12, a guiding sector 13 and an open sector 14. The closing member is attachable to the valve shaft 7 via an attaching part 15 in such a way that the end of the shaft is passed into the annular attaching part and after this attached to place with a pin to be passed through openings 16. However, in accordance with the invention, it is also feasible to use a structure in which the closing member and the shaft are of the same piece and not separate parts as in the example of the figures. Such a structure is advantageous in the sense that it allows the problem relating to the joint of the closing member and the shaft as regards parallelism and concentricity to be avoided.

[0015] The closing sector 11 shuts off the flow through the valve when the closing member 4 is turned into a position in which the closing sector covers the opening 10 in the wall of the housing 3.

[0016] The flexible sector 12 is delimited by the closing sector 11 and has a thinner wall than the closing sector. This makes the required flexibility properties possible without a need to use in the flexible sector 12 material deviating from the other cylindrical sectors of the closing member. In the example of the figures, radius R2 of the outer surface of the flexible sector 11 is smaller than radius R of the outer wall of the closing sector.

[0017] The guiding sector 13 is delimited by the flexible cylindrical sector 12.

[0018] The open sector 14 allows the flowing medium to flow unrestrictedly through the valve when the closing member 4 is turned into a position in which the open sector 14 is positioned at the point of the opening 10 of the housing 3. The open sector 14 also allows the closing member 4 to yield.

[0019] It is seen from Figures 4 and 5 that the attaching part 15 formed in the closing member for receiving the shaft is attached to at least the

closing sector 11 of the closing member. The attaching part is thus attached (in this example) to the end of the cylindrical closing member. In the case of the figures, the attaching part 15 may also be partly attached to the flexible sector 12. However, a slot 17 is arranged between the guiding sector 13 and the attaching part 15 in order for the attaching part 15 to be separated from the guiding sector 13. This slot 17 contributes to the flexibility of the closing member. Owing to the slot, the guiding sector 13 can yield relative to the closing sector 11 with a significantly smaller force than in a case where the attaching part 15 would also be attached to the guiding sector 13.

[0020] If the shaft and the closing member are of the same piece, the shaft is preferably attached as described above with reference to the attaching part 15. Thus, the shaft is attached to at least the closing sector, and it is separated from the guiding sector with a slot.

[0021] It is seen from Figure 6 that the guiding cylindrical sector 13 and the closing cylindrical sector 11 are opposite relative to the axis of rotation 6, and the size of both of them is under half of the circumference of the whole closing member 4.

[0022] Thanks to the above flexible structure it can be ensured that the guiding sector 13 coming into contact with the wall 9 of the housing positions the closing member 4 precisely at the desired point in the housing, whereby also the closing sector 11 becomes placed precisely at the desired point in such a way that the closing sector 11 closes the opening 10 with sufficient tightness by pressing against the wall of the housing at the point of the opening 10. If required, the tightness can be improved even more by arranging seal material around the edges of the opening 10, on the inner surface 9 and/or on the outer surface of the closing sector 11. Suitable seal material is sold under trade name TEFLON, for example.

[0023] In accordance with the invention, the closing member can be manufactured in such a way that the radius of the outer surface of the sector 11 is the same as radius R of the inner surface 9 of the wall of the housing 3. Also the radius of the outer surface of the guiding sector 13 may be the same as radius R of the inner surface 9 of the housing wall, in which case the tightness is the most efficient possible. However, if sufficient tightness can be achieved in another way, the radius of the outer surface of the guiding sector 13 may slightly deviate from the radius of the inner surface 9 of the housing wall.

[0024] If the outer surface of the closing sector and the outer surface of the guiding sector have the same radius as the inner surface of the housing wall, the housing 3 and the closing member 4 may be placed within each other also when the tolerances of the diameters cause a press fit. The tolerance needs not be, however, set such that the diameter of the outer surface of the closing member is smaller than the inner diameter of the housing but a working valve is also provided when the tolerances are opposite, in other words when the diameter of the outer surface of the closing member is larger than the inner diameter of the housing. In such a case, the open sector 14 and the flexible sector 12 allow small reciprocal movement of the closing sector 11 and guiding sector 13 without there remaining significant strain states affecting the operation. The structure also allows diameter variations due to temperature differences.

[0025] In connection with the installation, the closing member 4 guides the sleeve functioning as the housing 3 to be concentric and parallel to the closing member. The closing member becomes thus positioned at the precisely desired point relative to the housing. Owing to the structure of the closing member 4, the sealing surfaces are in continuous contact, whereby the sharp edges of the surfaces of the closing member 4 scrape out the particles possibly stuck on the sealing surface that could, when getting between the surfaces, prevent the sealing. The continuous contact due to the flexibility of the closing member 4 ensures the sealing also with small pressure differences over the closing member 4, whereby the sealing is at its most efficient when such a housing and closing member are used that have the same diameter as the inner surface of the housing.

[0026] As described above with reference to the figures, the closing member comprises a closing sector, a flexible sector, a guiding sector and an open sector in this order. In accordance with the invention it is, however, feasible that the order of the sectors is deviating or that one or more of the above-mentioned sectors are formed of sectors with guiding edges, joined together by a flexible sector between them.

[0027] With reference to the figures, it has also been described that the housing 4 is cylindrical and that the sectors 11, 12 and 13 are cylindrical sectors. However, it is also feasible in accordance with the invention that the shape of the housing and the sectors is not cylindrical but something else. One alternative is thus to utilize a conical housing, such as a housing formed of a

sleeve of the shape of a truncated cone. Thus, the outer surface of the closing sector may have the same radius as the inner surface of the housing wall at the height corresponding to each other, when moving in the direction of the axis of rotation. The diameter of the housing and the closing sector thus increases correspondingly. Hence, the diameter of the outer surface of the guiding sector may also correspond to the diameter of the inner surface of the housing wall at the height corresponding to each other, if the intention is to provide a housing and a closing member having the same diameter.

[0028] It is to be understood that the above description and the related figures are only intended to illustrate the present invention. Different variations and modifications of the invention without deviation from the scope of the invention will be obvious to a person skilled in the art.

CLAIMS

1. A valve, comprising
 - a housing (3) whose wall has an inner surface (9) curving around an axis of rotation (6) and which joins together a first (1) and a second part (2) of a flow channel, of which at least the first or the second part (2) is connected to the housing (3) via an opening (10) in the wall of the housing,
 - a closing member (4) arranged in the housing, from which member a shaft (7) protrudes via which the closing member (4) is rotatable in the housing (3) around said axis of rotation (6) between a position covering the opening (10) and a position uncovering the opening, characterized in that the closing member (4) comprises
 - a sector (11) closing the opening (10),
 - a flexible sector (12) having a thinner wall than the closing sector (11),
 - a guiding cylindrical sector (13) in contact with the housing wall to position the closing member relative to the housing, and
 - an open sector (14).
2. A valve according to claim 1, characterized in that said housing (3) is formed of a sleeve attached to the valve.
3. A valve according to claim 1 or 2, characterized in that a seal material layer is arranged on the inner surface (9) around the edges of the opening (10) or on the outer surface of the closing sector (11).
4. A valve according to any one of claims 1 to 3, characterized in that one end of the housing (3) has an opening for connecting the housing (3) to the first (1) or the second part (2) of the flow channel.
5. A valve according to any one of claims 1 to 4, characterized in that said guiding sector (13) is opposite to the closing sector (11) relative to the axis of rotation (6).
6. A valve according to any one of claims 1 to 5, characterized in that the closing sector (11) in the closing member (4) is delimited by the flexible sector (12), the guiding sector (13) is delimited by the flexible sector (12), and that there is an open sector (14) between the guiding sector (13) and the closing sector (11).

7. A valve according to any one of claims 1 to 6, characterized in that the housing (3) is of a cylindrical shape.

8. A valve according to any one of claims 1 to 6, characterized in that said housing is of a conical shape.

9. A valve according to any one of claims 1 to 8, characterized in that the outer surface of the closing sector (11) and the inner surface (9) of the housing wall have the same radius at the height corresponding to each other, when moving in the direction of the axis of rotation (6).

10. A valve according to any one of claims 1 to 9, characterized in that the outer surface of the guiding sector (13) and the inner surface (9) of the housing wall have the same radius at the height corresponding to each other, when moving in the direction of the axis of rotation (6).

11. A valve according to any one of claims 1 to 10, characterized in that the shaft (7) is joined to the closing member via the closing sector (11).

12. A valve according to claim 11, characterized in that the shaft (7) is separated from the guiding sector of the closing member with a slot.

13. A valve according to any one of claims 1 to 11, characterized in that the closing member is provided with an attaching part (15) for receiving said shaft (7), the attaching part (15) being attached to at least the closing sector (11) of the closing member and separated from the guiding sector (13) with a slot.

1/3

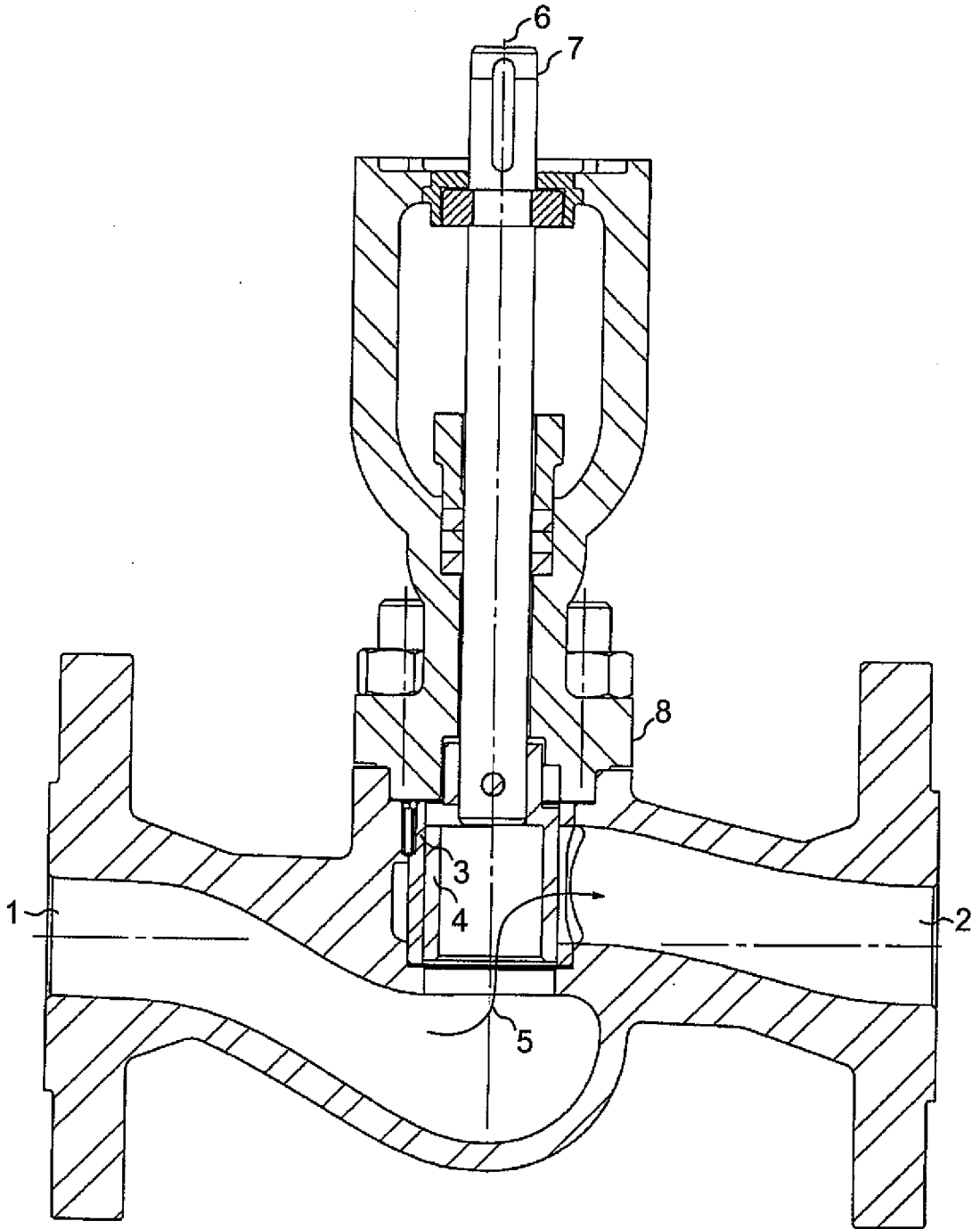

FIG. 1

2/3

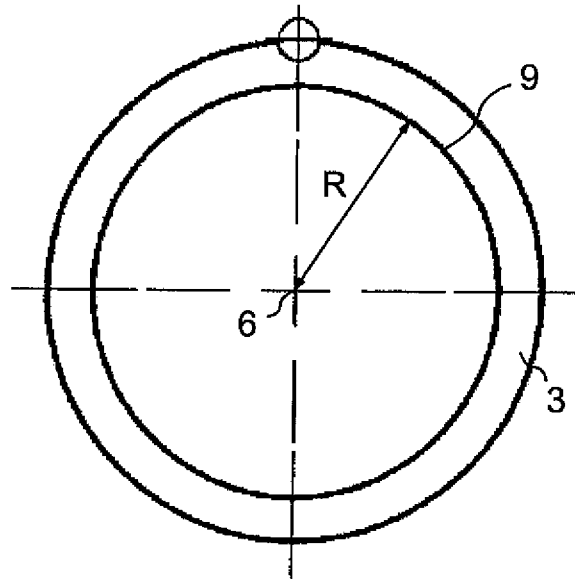

FIG. 2

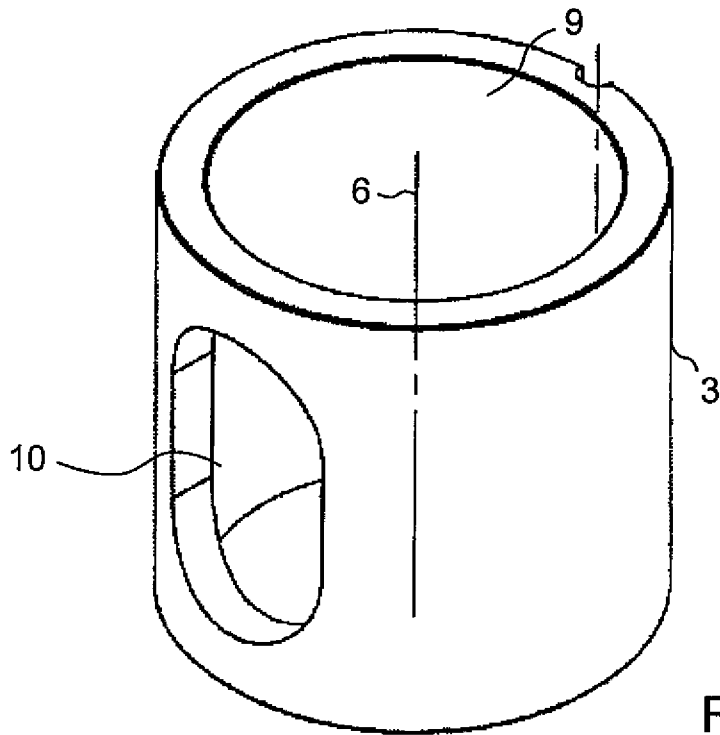

FIG. 3

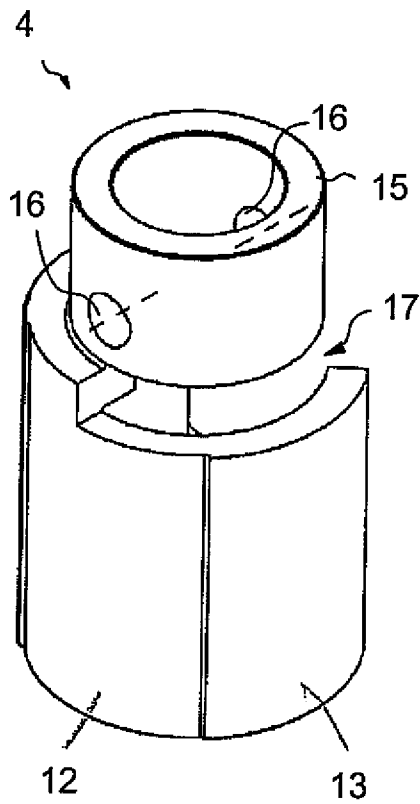

FIG. 4

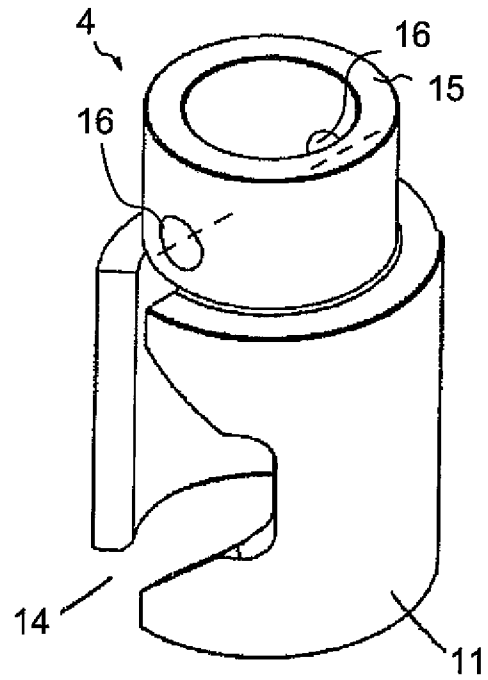

FIG. 5

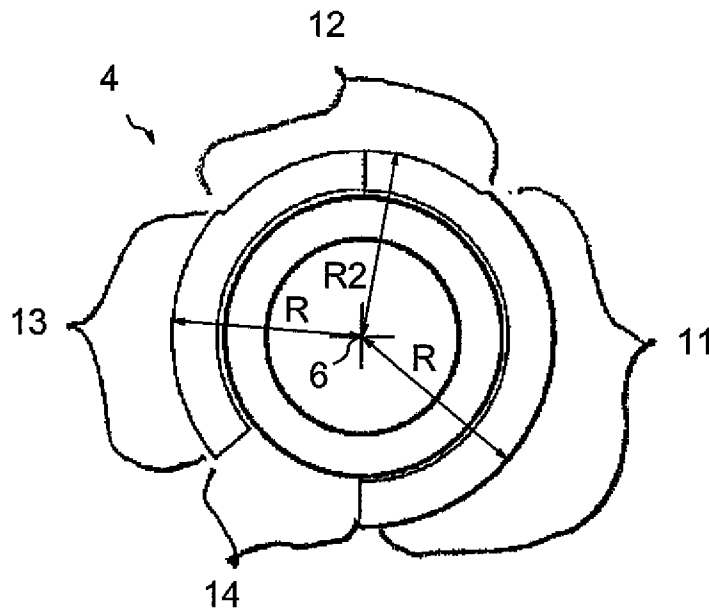

FIG. 6

INTERNATIONAL SEARCH REPORT

International application No.

PCT/FI2008/050103

A. CLASSIFICATION OF SUBJECT MATTER

See extra sheet

According to International Patent Classification (IPC) or to both national classification and IPC

B. FIELDS SEARCHED

Minimum documentation searched (classification system followed by classification symbols)

IPC8: F16K

Documentation searched other than minimum documentation to the extent that such documents are included in the fields searched

FI, SE, NO, DK

Electronic data base consulted during the international search (name of data base and, where practicable, search terms used)

EPO-Internal, WPI

C. DOCUMENTS CONSIDERED TO BE RELEVANT

| Category* | Citation of document, with indication, where appropriate, of the relevant passages | Relevant to claim No. |
|-----------|---|-----------------------|
| A | US 1138613 A (WILLIAM E. ARNDT) 11 May 1915 (11.05.1915), figure 3 | 1-13 |
| A | US 2639882 A (CONRAD CHARLES W) 26 May 1953 (26.05.1953), figure 2 | 1-13 |
| A | US 2346052 A (CECIL SEAMARK LEWIS MERVYN) 04 April 1944 (04.04.1944), figures 1 and 8 | 1-13 |
| A | GB 124984 A (BUTTERFIELD JOSEPH BOOTH) 10 April 1919 (10.04.1919), figures 1 and 2 | 1-13 |

 Further documents are listed in the continuation of Box C.

 See patent family annex.

* Special categories of cited documents:

"A" document defining the general state of the art which is not considered to be of particular relevance

"E" earlier application or patent but published on or after the international filing date

"L" document which may throw doubts on priority claim(s) or which is cited to establish the publication date of another citation or other special reason (as specified)

"O" document referring to an oral disclosure, use, exhibition or other means

"P" document published prior to the international filing date but later than the priority date claimed

"T" later document published after the international filing date or priority date and not in conflict with the application but cited to understand the principle or theory underlying the invention

"X" document of particular relevance; the claimed invention cannot be considered novel or cannot be considered to involve an inventive step when the document is taken alone

"Y" document of particular relevance; the claimed invention cannot be considered to involve an inventive step when the document is combined with one or more other such documents, such combination being obvious to a person skilled in the art

"&" document member of the same patent family

Date of the actual completion of the international search

23 June 2008 (23.06.2008)

Date of mailing of the international search report

27 June 2008 (27.06.2008)

Name and mailing address of the ISA/FI
National Board of Patents and Registration of Finland
P.O. Box 1160, FI-00101 HELSINKI, Finland

Facsimile No. +358 9 6939 5328

Authorized officer

Juha Vuorela

Telephone No. +358 9 6939 500

INTERNATIONAL SEARCH REPORT
Information on patent family members

International application No.
PCT/FI2008/050103

| Patent document cited in search report | Publication date | Patent family members(s) | Publication date |
|--|------------------|--------------------------|------------------|
| US 1138613 A | 11/05/1915 | None | |
| US 2639882 A | 26/05/1953 | None | |
| US 2346052 A | 04/04/1944 | None | |
| GB 124984 A | 10/04/1919 | None | |

CLASSIFICATION OF SUBJECT MATTER

Int.Cl.

F16K 5/18 (2006.01)

F16K 5/16 (2006.01)