

J. W. FREE.
Grain Separator.

2 Sheets—Sheet 1.

No. 52,841.

Patented Feb. 27, 1866.

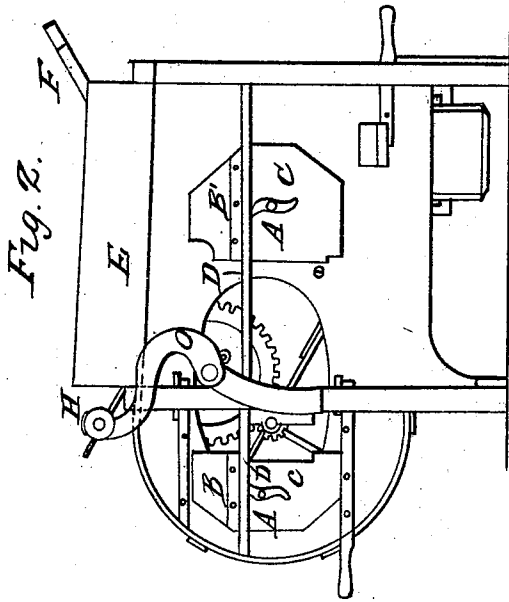

Fig. 2.

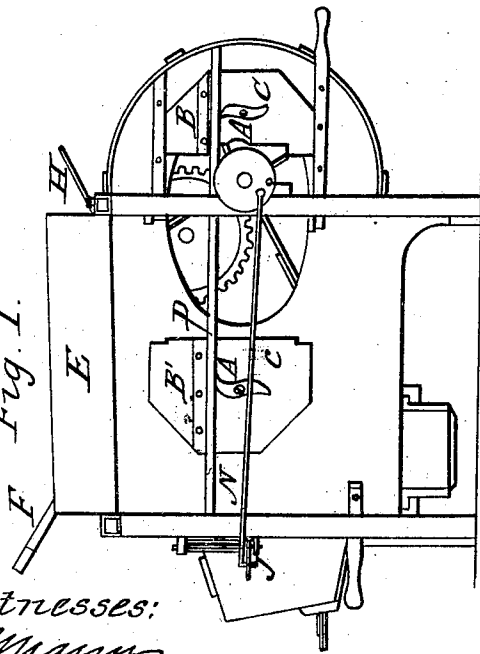

Fig. 1.

Witnesses:
R. Mann
L. Murphy.

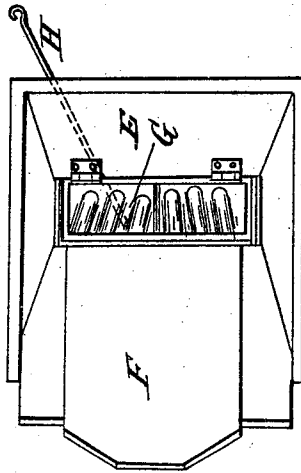

Fig. 4.

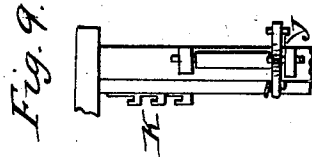

Fig. 9.

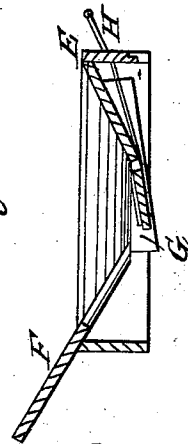

Fig. 3.

Inventor:
John W. Free

J. W. FREE.
Grain Separator.

No. 52,841.

Patented Feb. 27, 1866.

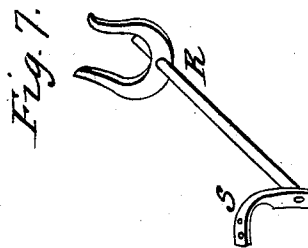
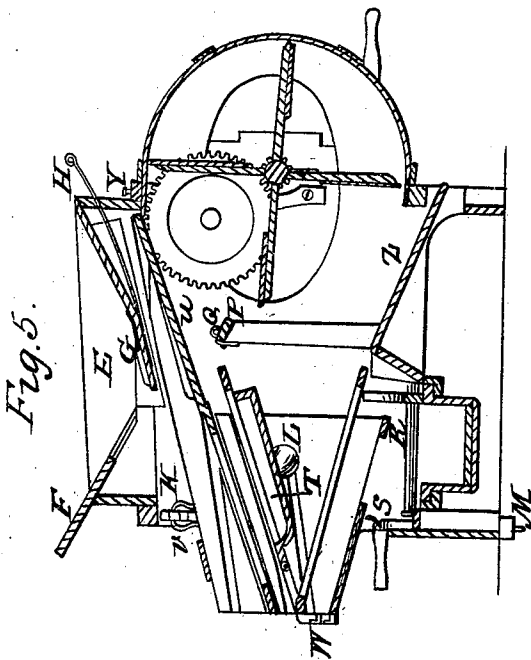
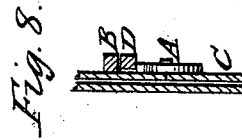
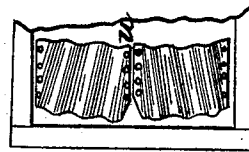
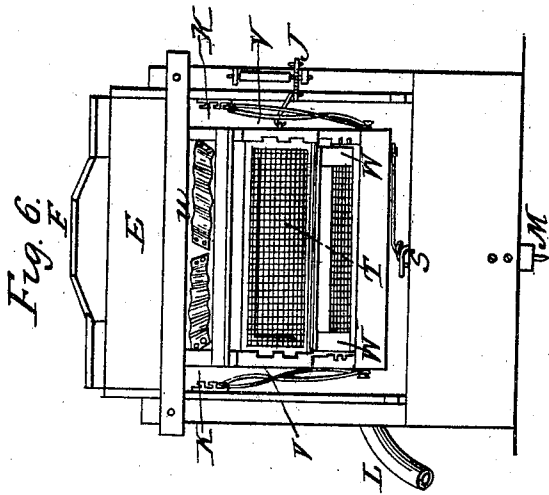

Witnesses:
R. Mann
L. Murphy

Inventor:
John W. Free

UNITED STATES PATENT OFFICE.

JOHN W. FREE, OF RICHMOND, INDIANA.

IMPROVEMENT IN GRAIN-SEPARATORS.

Specification forming part of Letters Patent No. 52,841, dated February 27, 1866.

To all whom it may concern:

Be it known that I, JOHN W. FREE, of Richmond, in the county of Wayne and State of Indiana, have invented certain new and useful Improvements in Grain and Seed Separators and Smut-Machines combined; and I do hereby declare that the following is a full, clear, and exact description of the same, reference being had to the accompanying drawings, made part of this specification, in which—

Figure 1 represents the side of my improved fanning-mill opposite to that on which the crank is attached. Fig. 2 represents the side on which the crank is attached. Fig. 3 is a sectional view of the hopper. Fig. 4 is a plan of the hopper. Fig. 5 is a vertical longitudinal section of the separator. Fig. 6 is an end view as seen from the rear. Fig. 7 is a view of the vibrating lever. Fig. 8 is a vertical section of the fan-door. Fig. 9 is a detached view of the bell-crank and suspending-ratchets.

The frame, fan, and shoe are constructed in the ordinary manner, with such modifications as will be hereinafter indicated.

The wind-holes in the side of the case are closed by the slides or doors C C', which fit snugly against the side of the case, sliding behind the bar D upon the cleats B B', and fixed in any required position by the cam-catches A shutting against the bar D.

The hopper E receives the grain upon two adjustable doors, F and G. F slides in grooves and G opens downward on hinges, and is controlled by the lever H passing through the front of the hopper and held by notches in the side of the slot through which it works. These two doors regulate the supply of grain to the screens. The grain thus admitted falls upon the upper cheat or chess board, which board is provided with movable tin slats or spreaders, which may be so adjusted as to cause the grain and seeds to fall in an even sheet upon the sieve. Through this the small grain falls upon the box T. I make it as shown in Figs. 5 and 6. The upper portion is of fine wire-gauze, and through it the timothy-seed mixed with the wheat passes into the box, from whence it is discharged through the flexible pipe I, made of tin, india-rubber, or any similar material. The wheat and other small grains fall then upon the lower screen, X. The

light stuff is expelled by the air-blast when passing from the box T to and over the screen X. The cockle, cheat, and similar small grains pass through X and are secured in the box. The wheat falls upon the lower grain-board, Z, whence it is discharged through an opening in the front of the machine.

The front end of the lower screen, X, rests upon the two points of the horseshoe-shaped end R of the vibrating lever, which is attached by the bent lever S, by a rod, to the lower corner of the shoe. This lever vibrating upon its axis gives the lower end of the screen X a vertical action by the effect of the arms R, while it has, with the shoe, a vibratory horizontal motion. This screen is held in place at the upper or rear end by pins projecting from the side catching into the ratchets W, which are notched as shown, so as to prevent the escape of the pins.

The shoe is suspended by the double hinge Y, Fig. 5, which permits its free motion as far as is necessary, both longitudinally and laterally, which motions combined give it a rotary motion, and at the rear, on either side, by the suspending rods or stirrups V, attached below, and hanging by eyes in their upper ends upon the upper hook-formed ratchets, K, on the side of the corner-post of the frame.

Upon the upper grain-board are placed corrugated plates U, attached to the board by screws, upon which they can be turned, so as to regulate the flow of the grain and distribute it upon the lower screens in an even sheet, thus counteracting the natural tendency of round particles upon an oscillating surface to collect in the center.

The vibratory motion of the shoe is communicated by a bell-crank attached to the rear of the post, so as to permit the rod connecting the crank with the shoe, instead of being brought at right angles to the side of the shoe, as is done in other mills, to be carried forward and attached so as to stand at an angle of about forty-five degrees to the side of the shoe. By this means the shoe, hanging upon the double hinge in front and the stirrups, receives a motion forward and back, as well as laterally.

Across the separator, behind the fan, passes the wind-guide P. This is a board about four or five inches wide, attached to boards on each

side by hinges upon one of its edges, upon which it swings up or down, being regulated by the hand and held in its place by the bolt Q, working into holes in the side of the case and held by a spiral spring. This wind-guide gives direction to the blast, and is especially useful in chaffing grains.

My improved grain and seed separator and smut-machine combined does not rest on four legs at the corners of the frame, as is done in ordinary fanning-mills, but rests upon the two corner-posts in front, and in rear upon the leg *m* placed in the middle of the rear part of the frame. By means of these three legs the separator will stand firmly upon uneven surfaces.

The operation of the grain and seed separator and smut-machine combined is fully indicated in the foregoing portions of this specification.

Having fully explained the construction and operation of my invention, what I claim as my invention, and seek to secure by Letters Patent, is—

1. The combination of the cam A, bar D, door C, and cleat B, when used in the manner and for the purpose set forth.

2. The double hinge Y, when used in the manner and for the purpose set forth.

3. The hook-shaped ratchets K, in combination with the suspending-rods V and the shoe, when used as and for the purpose set forth.

4. The bell-crank J, in combination with the double hinge Y, when used to give a longitudinal as well as transverse vibrations to the shoe, thus producing a rotary or circular motion, by means of a rod attached, substantially as and for the purpose set forth.

5. The foot M of the frame, in combination with the feet upon the other end, substantially as and for the purpose set forth.

6. The rocking levers R S, in combination with the shoe and screen X, when employed substantially as and for the purpose set forth.

7. The wind-guide P, in combination with the spring-bolt Q, substantially as and for the purpose set forth.

8. The box T, in combination with the shoe, when constructed and used substantially as and for the purposes set forth.

9. The adjustable corrugated plates U and G, constructed and used substantially as and for the purposes set forth.

In testimony whereof I have signed my name to this specification in the presence of two subscribing witnesses.

JOHN W. FREE.

Witnesses:

CYRUS J. THOMPSON,
LEWIS D. STUBBS.