

F. J. GRACE.

Telegraph.

No. 102,252.

Patented April 26, 1870.

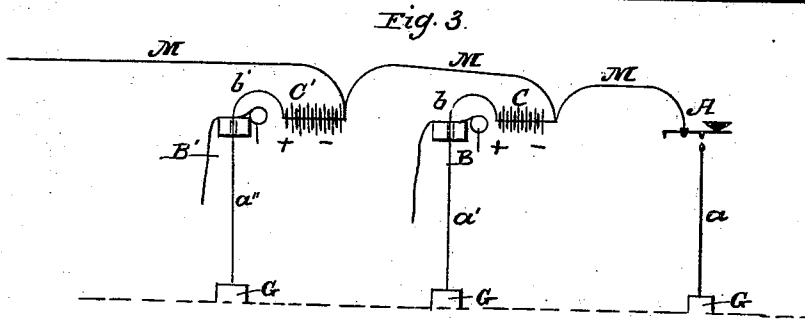
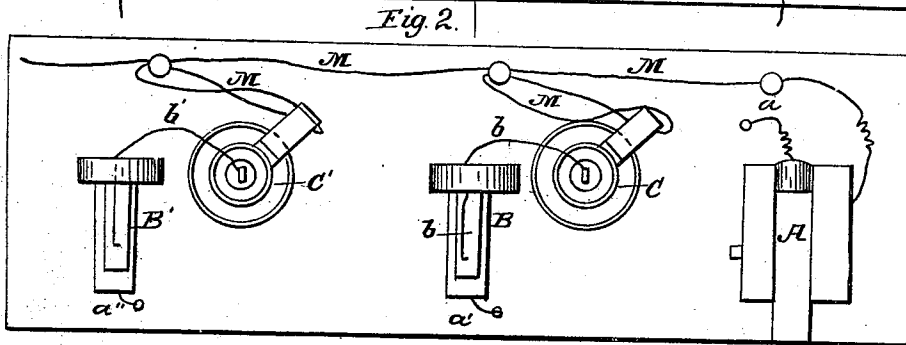
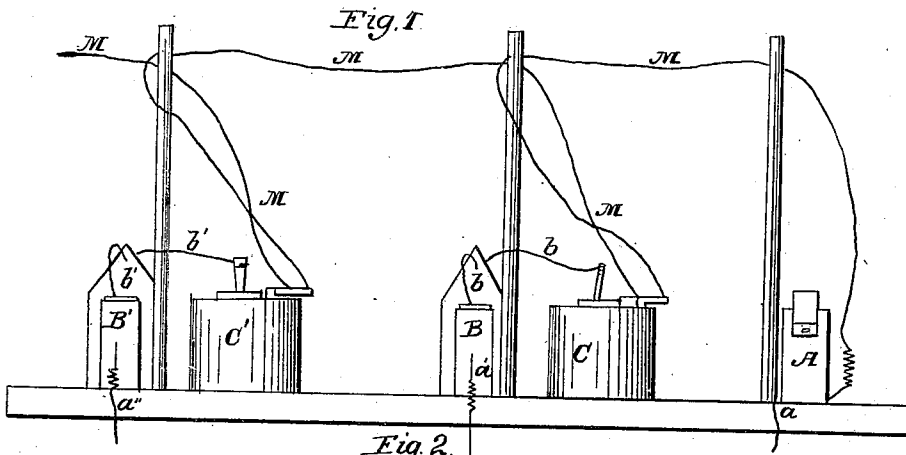

Witnesses:  
M. M. Murphy  
J. B. Becker

Inventor:  
Frederick J. Grace

# United States Patent Office.

FREDERICK J. GRACE, OF COYTESVILLE, NEW JERSEY.

Letters Patent No. 102,252, dated April 26, 1870.

## IMPROVED SYSTEM OF TELEGRAPHING.

The Schedule referred to in these Letters Patent and making part of the same.

To all whom it may concern:

Be it known that I, FREDERICK J. GRACE, of Coytesville, in the county of Bergen and State of New Jersey, have invented a new and useful Improvement in Telegraphy; and I do hereby declare that the following is a full, clear, and exact description of the same, reference being had to the accompanying drawing which forms part of this specification.

The object of this invention is to provide a method or means whereby "drop" copies of a message can be taken at one or more intermediate stations, on a wire operated by either the "Bain," so called, or chemical system of telegraphy, the *fac-simile* method, or any system of electro-telegraphy which is dependent upon the discoloration or decomposition of chemicals in the paper or message-blank by the passage of electricity.

Heretofore it has been impossible, by any electro-chemical system of telegraphy to have communication with more than one station at any one time, for reasons and peculiarities well known to telegraph operators and all persons acquainted with the art.

My invention consists in a certain novel arrangement of wires and batteries, so as to insure the production simultaneously at many and distant stations upon the same wire, of any effect produced at one.

The accompanying drawing represents, by—

Figure 1, a side elevation of an arrangement or means whereby my invention may be put into practice, and by

Figure 2, a plan view of the same is shown.

Figure 3 is a diagram, showing the arrangement in outline.

It will be understood that, in transmission, no battery whatever need necessarily be used by the transmitting office.

A designates an ordinary key used in the transmission of telegraphic signals. One pole of this key is connected directly to the earth, the other to the main line M.

B designates a receiving instrument at a remote point, say at another office, and this is connected to the ground by a ground wire, *a'*; and this instrument is supplied with suitably-prepared paper, or its equivalent, by any suitable mechanism at present in use.

A wire or pen, *b*, is connected to one pole of a battery C, and so arranged that it will traverse the paper or message-blank.

The other pole of said battery C is connected with and constitutes a part of the main line M. Hence, if the poles of the key A become connected, a circuit is formed from the earth at *a*, through key A, line M, battery C, pen *b*, instrument B, and wire *a'*, to the earth, the current generated at battery C passing through the paper on the instrument B, leaving a discoloration equal in length to the duration of the close at key A.

The same effect is produced at the next remote office by means of the battery C, wire or pen *b'*, instrument B, and ground wire *a'*, the said main line M being connected to the battery C, in the manner previously described. And the same effect may be produced at any desired number of offices upon the same wire, the connection with the earth, as at *a*, giving the required circuit for each and every office receiving, the batteries at each office being entirely independent of each other, and only requiring the ground connection given by the transmitting instrument over the main line to set each and every one in action simultaneously. And the same effect would be produced, were raised or depressed characters in metal, or characters written upon paper or its equivalent with insulating ink, or by depressions or elevations in said paper or its equivalent, or by paper or its equivalent being "punched" or portions cut out so as to form characters for transmission, substituted for the key A.

The circuit in these cases could be closed by a traversing pen or by a key or by any desirable means.

It will, therefore, appear obvious from the above description that my invention provides a means whereby a message may be recorded simultaneously at many and distant stations by the same wire, at whichever station the said wire may be affected.

What I claim as my invention, and desire to secure by Letters Patent, is—

1. The combination and arrangement of the main line and battery or batteries at the several stations on a telegraphic circuit, substantially as and for the purposes herein specified.

2. The arrangement of the main line as a ground wire with respect to batteries at remote points, substantially as and for the purpose herein specified.

FREDERICK J. GRACE.

Witnesses:

M. M. LIVINGSTON,  
F. B. BEECHER.