

J. HILTPOLD.  
LOCK AND LATCH.  
APPLICATION FILED MAY 8, 1906.

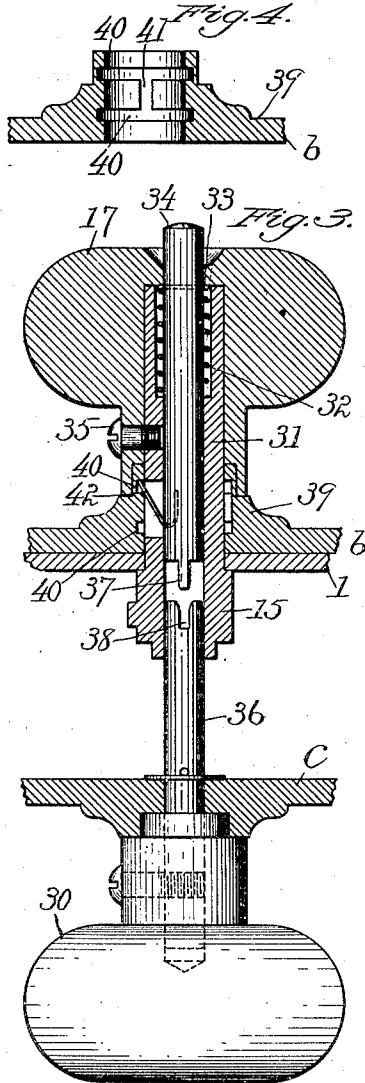
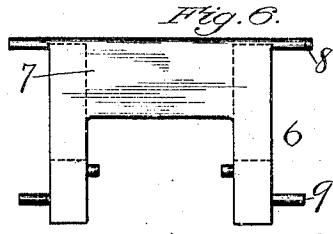
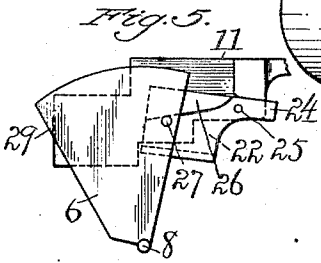
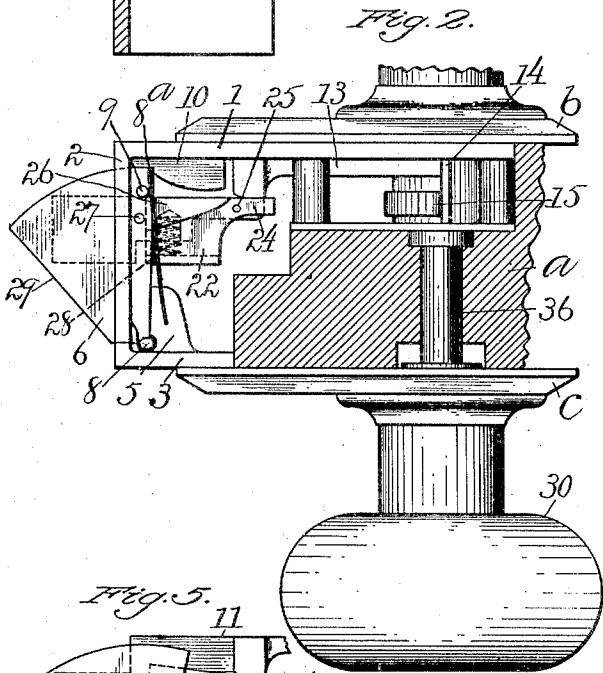
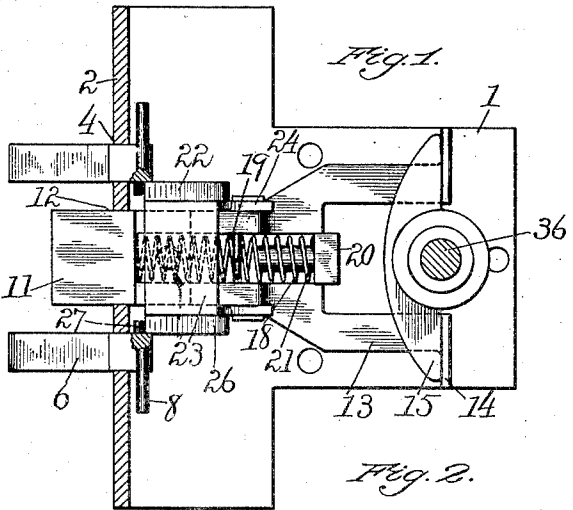

Witnesses.  
C. F. Stone  
S. E. Bukovitch

Inventor  
John Hiltbold.  
per Arthur O. Jenkins,  
Attorney

# UNITED STATES PATENT OFFICE.

JOHN HILTPOLD, OF NEW BRITAIN, CONNECTICUT.

## LOCK AND LATCH.

No. 868,782.

Specification of Letters Patent.

Patented Oct. 22, 1907.

Application filed May 8, 1906. Serial No. 315,788.

*To all whom it may concern:*

Be it known that I, JOHN HILTPOLD, a citizen of the United States, and a resident of New Britain, in the county of Hartford and State of Connecticut, have invented a new and Improved Lock and Latch, of which the following is a specification.

My invention relates more especially to that class of locks and latches in which the bolt is manually operated as by means of a spindle connected with a knob or by other means, and the object of my invention among others is to provide a lock of this class of comparatively few parts, simple in construction, and with the parts so formed as to prevent the bolt being surreptitiously thrown; and a further object of the invention is to provide such means that while allowing operation of the bolt by means of the knob on the outer side of the door shall be self actuating to disconnect said knob from the bolt operating mechanism. A form of device in the use of which these objects may be attained is illustrated in the accompanying drawings, in which—

Figure 1 is a view in elevation through the case of my improved lock showing the parts with the bolt projected from the case. Fig. 2 is a top or edge view of the device shown in Fig. 1 and also showing the means of attachment to a door. Fig. 3 is a detail view showing the means for connecting the outer knob with the operating mechanism. Fig. 4 is a detail view in lengthwise section through the rosette on the inner face of the door. Fig. 5 is a detail view showing the position of the trip to allow return movement of the cam levers. Fig. 6 is a detail view in elevation of the cam levers.

While my invention contemplates a lock case in which the parts may be entirely inclosed, the operating spindle, bolts and cams, of course, projecting therefrom, yet a convenient form of construction is shown herein, in which the parts are inclosed within the door partially by the base plate, and partially by face plates. I have, however, as an aid to the description termed the parts supporting the operative elements a case, this consisting of a base plate 1 having an end wall 2 and a flange 3. Openings 4 are formed through the end wall, and spring supporting lugs 5 project from the flange 3.

Cam levers 6 are pivoted to the case in position to project through the openings 4, as shown in Figs. 1 and 2 of the drawings. While two cam levers are shown herein, it will be obvious that the employment of a single cam lever will accomplish the same result, but by employing a number of cam levers force is applied equally upon opposite sides of the bolt to draw it backward and thus prevent any cramping action. As shown herein, these cam levers are rigidly connected by a cross-bar 7 terminating in supporting pins 8. These pins are preferably located in a recess formed between the lugs 5 and the end wall 2, as shown in Fig. 2 of the drawings. Springs 8<sup>a</sup>, the ends of which bear against pins 9, hold the levers normally at the outward limit of

their play. Guide lugs 10 for the bolt are formed on the base plate 1, and a bolt 11 is mounted between these lugs in position to project through a bolt opening 12 in the end wall 2 of the case. This bolt is of rectangular form in cross-section throughout the entire length of that part projecting through the end wall 2 of the case. This bolt is provided with the usual branches 13 having toes 14 against which the roll-back 15 acts, this roll-back being operated in the usual manner by means of a spindle and knob 17 located on the inner face of the door. A spring 18 located in a recess 19 in the bolt thrusts against a spring stop 20 projecting from the base plate 1. A stud 21 may be employed for holding the spring against lateral movement.

A bolt trip is pivotally mounted upon the bolt, this trip, when seen in end view, being of U-shape and including the side parts 22 joined by the plate 23. Extensions 24 from the side parts provide means for pivotally mounting the trip, the pivot 25 passing through the bolt and into these extensions 24. Trip cams 26 are formed on the side parts of the trip, the forward edge of these trip cams being formed to engage trip pins 27 on the cam levers 6. A trip spring 28 is located between the trip and the bolt 11, as shown in dotted lines in Fig. 2 of the drawings.

It will be noted that the bolt being of rectangular form in cross-section as to the entire part projected from the casing, that it will be impossible to throw the bolt backward as by means of an instrument inserted between the edge of the door and the door jamb or strike plate, for the reason that there is no beveled surface upon which such instrument may act. The door being opened, as it is closed and the case thus moved with respect to the door frame the beveled surfaces 29 on the levers 6 engaging the strike plate, these levers are forced backward, carrying the bolt 11 also backward by reason of the pins 27 engaging the trip cams 26. As the levers, swinging upon pivots 8, are moved inward the pins 27 are carried across the engaging face of the trip cams 26 until they pass beyond the limits of such face. The parts are so constructed that this disengagement of the pins 27 from the trip cams 26 will occur at a time when the end of the bolt has been located opposite the strike plate. The bolt being freed is forced forward under the influence of the spring 18 against the strike plate, and when the door has moved to position with the bolt opposite its keeper, it flies into the socket and securely holds the door against opening movement, the cam plates 6 being held in a retracted position by engagement with the strike plate. As the door is opened and the cam levers are forced outward under the influence of the springs 8<sup>a</sup> the trip yields to allow passage of the pins 27, as shown in Fig. 5 of the drawings.

In order to provide for the operation of the bolt by means of the knob 30 located outside of the door the

following mechanism is employed. The roll-back 15 has a sleeve 31 extending within the knob 17, and within this sleeve is located a spring 32 pressing against a pin 33 in a push spindle 34. This spring firmly holds the push spindle at the outward limit of its play or in the position shown in Fig. 3 of the drawings. The knob is secured to the sleeve 31 as by a screw 35. The end of the spindle 36 of the knob 30 and of the push spindle 34 are formed to interlock, in the construction shown a tongue 37 on the one part entering a groove 38 in the other part. As the push spindle 34 is moved inward the tongue and groove engage so that the roll-back may be operated by means of the knob 30.

15 A rosette 39 is secured to the inner face of the door and this rosette projects within the shank of the knob 17, as shown in Fig. 3. This rosette has two annular grooves 40 joined by a connecting groove 41. A pawl 42 is secured to the push spindle 34, its end lying within one of the grooves 40, as shown in Fig. 3 of the drawings.

When it is desired to set the mechanism so that the bolt may be operated by the knob outside of the door the push spindle 34 is moved inward from the position shown in Fig. 3 until the pawl 42 engages the other groove from that in which it is shown as located in said Fig. 3. This locks the push spindle 34 with the spindle 36, and upon rotating the knob 30 the roll-back 15 will be rotated to operate the bolt. In this turning movement, however, of the knob 30 the pawl 42 will be moved around in the groove in which it is located when the two spindles are engaged until it arrives opposite the connecting groove 41. The spring 32 will be comparatively weak, so that continued pressure upon the knob 30 will hold the two spindles in engagement. When pressure upon the knob 30, however, is released the pawl 42 as it arrives opposite the groove 41 will move along said groove under the influence of the spring 32 and the two spindles will be thus disengaged.

40 While, as hereinbefore stated, the mechanism may be entirely inclosed within a casing, yet a convenient form of constructing the device is as shown herein. In this instance, the door *a* is cut away entirely through from one face to the other and face plates *b-c* are employed to cover the openings thus made. The face plate *c* will preferably extend beyond the flange 3 a sufficient distance to prevent any chance of cutting away the wood of the door for access to the lock. The rosette 39 may be formed integral with the plate *b*, as shown in Fig. 3 of the drawings.

What I claim as my invention and desire to secure by Letters Patent is:—

1. A case, a bolt movably mounted within the case, means for retracting the bolt, a bolt operating cam, and connections between said bolt and cam arranged to disconnect the parts in the backward movement of the bolt.

2. A case, a bolt movably mounted within the case, means for retracting the bolt, a bolt operating cam, a trip located on the bolt, and connections between said cam and trip arranged to be disconnected in the backward movement of the bolt.

3. A case, a bolt movable within the case, a trip mounted on the bolt, a bolt operating cam, and connections between said trip and cam arranged to disconnect the parts in the backward movement of the bolt but to allow movement of the cam independently of the bolt.

4. A case, a bolt movably mounted within the case, means for retracting the bolt, a cam lever projecting to

engage a strike plate, and connections between said lever and bolt to move the latter, said connections being broken at times.

5. A case, a bolt movably mounted in the case, means actuated by the movement of a part bearing the case for actuating the bolt, and connections between the bolt and operating means arranged for operative connection and disconnection.

6. A case, a bolt movably mounted within the case, means for retracting the bolt, a cam lever movably mounted within the case, a trip mounted on the bolt in the path of movement of the cam lever, and means for disengaging the trip from said cam lever.

7. A casing, a bolt movable within the casing, means for retracting the bolt, a cam lever movably mounted within the casing and having a pin projecting from the side thereof, a trip movably mounted on the bolt, and a cam located on said trip to act upon said pin in one movement of the lever, but to move and allow the pin to pass in the opposite movement of the lever.

8. A casing, a bolt movably mounted within the casing, a cam lever movably mounted within the casing, means for retracting the bolt, a trip pivoted to the bolt at opposite sides and with a part overlying the bolt, a spring interposed between the bolt and said trip, a cam located on the side of the strip in the path of movement of the lever, said cam having a cam face by means of which the trip is operated to allow movement of the lever independently of the bolt.

9. A sectional knob spindle, means for actuating said spindle, one section of said spindle being movable to engage the opposite section, a pawl to hold the spindle sections in engagement, and self-actuating means for releasing said pawl.

10. A sectional knob spindle, knobs secured to said spindle, one of the spindle sections projecting through the knob and movable with respect thereto, interengaging means on the two spindle sections, a pawl for holding the spindle sections in engagement, and self-actuating means for disengaging said pawl.

11. A case, a bolt movably mounted in the case, means for retracting the bolt, and a bolt operating cam connected with the bolt to retract it but arranged to be operatively disengaged therefrom.

12. A sectional knob spindle, knobs secured to said spindle, one of the knobs having a recess in the outer face thereof, one of said spindle sections projecting through the knob with the recess, a pawl to hold the knob spindles in engagement, interengaging means on the meeting ends of the spindles, and self-actuating means to disengage said pawl.

13. A sectional knob spindle having interengaging means on the spindle sections, knobs secured to said spindle, one of the spindle sections projecting through a knob, a spring in engagement with the movable section of the spindle to retract it, a pawl to hold the spindle sections in engagement, and self-actuating means for disengaging the pawl.

14. A sectional knob spindle, interengaging means on the ends of the spindle, means for operating the spindles, a pawl to hold the spindles in engagement, and self-actuating means for releasing the pawl.

15. A sectional knob spindle, interengaging means on the adjacent ends of the spindles, means for operating the spindles, a pawl mounted to rotate with said spindles, a member having grooves to receive said pawl to hold the movable spindle sections against lengthwise movement, and a groove uniting said holding grooves.

16. A sectional knob spindle, interengaging means on the adjacent ends of the spindles, a knob secured to one end of the spindle, the movable section of the spindle projecting through said knob, a pawl mounted to rotate with the spindle, a part having holding grooves for the reception of said pawl, and a releasing groove connecting the holding grooves, and a spring to retract the movable spindle.

17. In a latch mechanism, a sleeve, a roll-back secured to said sleeve, a sectional spindle having its movable section mounted within said sleeve and projecting through a knob, the knob secured to the sleeve, a pawl secured to the spindle and projecting through said sleeve, and a part hav-

ing locking grooves for the reception of the pawl, and a releasing groove uniting the locking grooves.

18. A case, a bolt mounted within the casing, means for retracting the bolt, a bolt actuating cam, and a trip connection between said bolt and cam.

19. A case, a bolt movably mounted within the case, means for moving the bolt in one direction, and connections between the moving means and bolt normally allowing movement of the latter in the opposite direction independently of its moving means.

20. A case, a bolt movably mounted within the case, manually operated means for moving the bolt, means for mechanically actuating the bolt, and connections between the mechanically actuating means and bolt to allow movement of the latter independently of the former.

21. A case, a bolt movable within the case, a trip mounted to move the bolt in one direction but to allow independent movement thereof in the opposite direction, a bolt operating cam, and connections between said trip and cam arranged for mechanical engagement and disengagement in the backward movement of the bolt.

22. A case, a bolt movably mounted within the case, self-actuating means for moving the bolt in one direction, and connections between said moving means and the bolt normally allowing movement of the latter in the opposite direction independently of its moving means.

JOHN HILFPOLD.

Witnesses:

ARTHUR B. JENKINS,  
HENRY OGILVY.