



- (51) International Patent Classification:
G09G 3/22 (2006.01)
- (21) International Application Number:
PCT/IB2012/052652
- (22) International Filing Date:
26 May 2012 (26.05.2012)
- (25) Filing Language: English
- (26) Publication Language: English
- (30) Priority Data:
61/490,870 27 May 2011 (27.05.2011) US
61/556,972 8 November 2011 (08.11.2011) US
- (71) Applicant (for all designated States except US): **IGNIS INNOVATION INC.** [CA/CA]; 50 Bathurst Drive, Unit 12, Waterloo, Ontario N2V 2C5 (CA).
- (72) Inventor; and
- (75) Inventor/Applicant (for US only): **CHAJI, Gholamreza** [CA/CA]; 463 Kelso Drive, Waterloo, Ontario N2V2S3 (CA).
- (81) Designated States (unless otherwise indicated, for every kind of national protection available): AE, AG, AL, AM, AO, AT, AU, AZ, BA, BB, BG, BH, BR, BW, BY, BZ, CA, CH, CL, CN, CO, CR, CU, CZ, DE, DK, DM, DO, DZ, EC, EE, EG, ES, FI, GB, GD, GE, GH, GM, GT, HN,

HR, HU, ID, IL, IN, IS, JP, KE, KG, KM, KN, KP, KR, KZ, LA, LC, LK, LR, LS, LT, LU, LY, MA, MD, ME, MG, MK, MN, MW, MX, MY, MZ, NA, NG, NI, NO, NZ, OM, PE, PG, PH, PL, PT, QA, RO, RS, RU, RW, SC, SD, SE, SG, SK, SL, SM, ST, SV, SY, TH, TJ, TM, TN, TR, TT, TZ, UA, UG, US, UZ, VC, VN, ZA, ZM, ZW.

(84) Designated States (unless otherwise indicated, for every kind of regional protection available): ARIPO (BW, GH, GM, KE, LR, LS, MW, MZ, NA, RW, SD, SL, SZ, TZ, UG, ZM, ZW), Eurasian (AM, AZ, BY, KG, KZ, RU, TJ, TM), European (AL, AT, BE, BG, CH, CY, CZ, DE, DK, EE, ES, FI, FR, GB, GR, HR, HU, IE, IS, IT, LT, LU, LV, MC, MK, MT, NL, NO, PL, PT, RO, RS, SE, SI, SK, SM, TR), OAPI (BF, BJ, CF, CG, CI, CM, GA, GN, GQ, GW, ML, MR, NE, SN, TD, TG).

Declarations under Rule 4.17:

- as to applicant's entitlement to apply for and be granted a patent (Rule 4.17(ii))
- as to the applicant's entitlement to claim the priority of the earlier application (Rule 4.17(iii))

Published:

- without international search report and to be republished upon receipt of that report (Rule 48.2(g))

(54) Title: SYSTEMS AND METHODS FOR AGING COMPENSATION IN AMOLED DISPLAYS

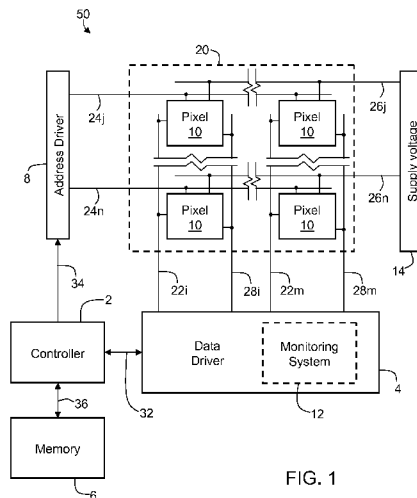

FIG. 1

(57) Abstract: Circuits for programming, monitoring, and driving pixels in a display are provided. Circuits generally include a driving transistor to drive current through a light emitting device according to programming information which is stored on a storage device, such as a capacitor. One or more switching transistors are generally included to select the circuits for programming, monitoring, and/or emission. Circuits advantageously incorporate emission transistors to selectively couple the gate and source terminals of a driving transistor to allow programming information to be applied to the driving transistor independently of a resistance of a switching transistor.

WO 2012/164475 A2

SYSTEMS AND METHODS FOR AGING COMPENSATION IN AMOLED DISPLAYS

FIELD OF THE INVENTION

[0001] The present disclosure generally relates to circuits for use in displays, and methods of driving, calibrating, and programming displays, particularly displays such as active matrix organic light emitting diode displays.

BACKGROUND

[0002] Displays can be created from an array of light emitting devices each controlled by individual circuits (i.e., pixel circuits) having transistors for selectively controlling the circuits to be programmed with display information and to emit light according to the display information. Thin film transistors (“TFTs”) fabricated on a substrate can be incorporated into such displays. TFTs tend to demonstrate non-uniform behavior across display panels and over time as the displays age. Compensation techniques can be applied to such displays to achieve image uniformity across the displays and to account for degradation in the displays as the displays age.

[0003] Some schemes for providing compensation to displays to account for variations across the display panel and over time utilize monitoring systems to measure time dependent parameters associated with the aging (i.e., degradation) of the pixel circuits. The measured information can then be used to inform subsequent programming of the pixel circuits so as to ensure that any measured degradation is accounted for by adjustments made to the programming. Such monitored pixel circuits may require the use of additional transistors and/or lines to selectively couple the pixel circuits to the monitoring systems and provide for reading out information. The incorporation of additional transistors and/or lines may undesirably decrease pixel-pitch (*i.e.*, “pixel density”).

SUMMARY

[0004] Aspects of the present disclosure provide pixel circuits suitable for use in a monitored display configured to provide compensation for pixel aging. Pixel circuit configurations disclosed herein allow for a monitor to access nodes of the pixel circuit via a

monitoring switch transistor such that the monitor can measure currents and/or voltages indicative of an amount of degradation of the pixel circuit. Aspects of the present disclosure further provide pixel circuit configurations which allow for programming a pixel independent of a resistance of a switching transistor. Pixel circuit configurations disclosed herein include transistors for isolating a storage capacitor within the pixel circuit from a driving transistor such that the charge on the storage capacitor is not affected by current through the driving transistor during a programming operation.

[0005] According to some embodiments of the present disclosure, a system for compensating a pixel in a display array is provided. The system can include a pixel circuit, a driver, a monitor, and a controller. The pixel circuit is programmed according to programming information, during a programming cycle, and driven to emit light according to the programming information, during an emission cycle. The pixel circuit includes a light emitting device, a driving transistor, a storage capacitor, and an emission control transistor. The light emitting device is for emitting light during the emission cycle. The driving transistor is for conveying current through the light emitting device during the emission cycle. The storage capacitor is for being charged with a voltage based at least in part on the programming information, during the programming cycle. The emission control transistor is arranged to selectively connect, during the emission cycle, at least two of the light emitting device, the driving transistor, and the storage capacitor, such that current is conveyed through the light emitting device via the driving transistor according to the voltage on the storage capacitor. The driver is for programming the pixel circuit via a data line by charging the storage capacitor according to the programming information. The monitor is for extracting a voltage or a current indicative of aging degradation of the pixel circuit. The controller is for operating the monitor and the driver. The controller is configured to receive an indication of the amount of degradation from the monitor; receive a data input indicative of an amount of luminance to be emitted from the light emitting device; determine an amount of compensation to provide to the pixel circuit based on the amount of degradation; and provide the programming information to the driver to program the pixel circuit. The programming information is based at least in part on the received data input and the determined amount of compensation.

[0006] According to some embodiments of the present disclosure, a pixel circuit for driving a light emitting device is provided. The pixel circuit includes a driving transistor, a

storage capacitor, an emission control transistor, and at least one switch transistor. The driving transistor is for driving current through a light emitting device according to a driving voltage applied across the driving transistor. The storage capacitor is for being charged, during a programming cycle, with the driving voltage. The emission control transistor is for connecting at least two of the driving transistor, the light emitting device, and the storage capacitor, such that current is conveyed through the driving transistor, during the emission cycle, according to voltage charged on the storage capacitor. The at least one switch transistor is for connecting a current path through the driving transistor to a monitor for receiving indications of aging information based on the current through the driving transistor, during a monitoring cycle.

[0007] According to some embodiments of the present disclosure, a pixel circuit is provided. The pixel circuit includes a driving transistor, a storage capacitor, one or more switch transistors, and an emission control transistor. The driving transistor is for driving current through a light emitting device according to a driving voltage applied across the driving transistor. The storage capacitor is for being charged, during a programming cycle, with the driving voltage. The one or more switch transistors are for connecting the storage capacitor to one or more data lines or reference lines providing voltages sufficient to charge the storage capacitor with the driving voltage, during the programming cycle. The emission control transistor is operated according to an emission line. The emission control transistor is for disconnecting the storage capacitor from the light emitting device during the programming cycle, such that the storage capacitor is charged independent of the capacitance of the light emitting device.

[0008] According to some embodiments of the present disclosure, a display system is provided. The display system includes a pixel circuit, a driver, a monitor, and a controller. The pixel circuit is programmed according to programming information, during a programming cycle, and driven to emit light according to the programming information, during an emission cycle. The pixel circuit includes a light emitting device for emitting light during the emission cycle. The pixel circuit also includes a driving transistor for conveying current through the light emitting device during the emission cycle. The current can be conveyed according to a voltage across a gate and a source terminal of the driving transistor. The pixel circuit also includes a storage capacitor for being charged with a voltage based at least in part on the programming information, during the programming cycle. The storage

capacitor is connected across the gate and source terminals of the driving transistor. The pixel circuit also includes a first switch transistor connecting the source terminal of the driving transistor to a data line. The driver is for programming the pixel circuit via the data line by applying a voltage to a terminal of the storage capacitor that is connected to the source terminal of the driving transistor. The monitor is for extracting a voltage or a current indicative of aging degradation of the pixel circuit. The controller is for operating the monitor and the driver. The controller is configured to: receive an indication of the amount of degradation from the monitor; receive a data input indicative of an amount of luminance to be emitted from the light emitting device; determine an amount of compensation to provide to the pixel circuit based on the amount of degradation; and provide the programming information to the driver to program the pixel circuit. The programming information is based at least in part on the received data input and the determined amount of compensation.

[0009] The foregoing and additional aspects and embodiments of the present invention will be apparent to those of ordinary skill in the art in view of the detailed description of various embodiments and/or aspects, which is made with reference to the drawings, a brief description of which is provided next.

BRIEF DESCRIPTION OF THE DRAWINGS

[0010] The foregoing and other advantages of the invention will become apparent upon reading the following detailed description and upon reference to the drawings.

[0011] FIG. 1 illustrates an exemplary configuration of a system for monitoring a degradation in a pixel and providing compensation therefore.

[0012] FIG. 2A is a circuit diagram of an exemplary driving circuit for a pixel.

[0013] FIG. 2B is a schematic timing diagram of exemplary operation cycles for the pixel shown in FIG. 2A.

[0014] FIG. 3A is a circuit diagram for an exemplary pixel circuit configuration for a pixel.

[0015] FIG. 3B is a timing diagram for operating the pixel illustrated in FIG. 3A.

[0016] FIG. 4A is a circuit diagram for an exemplary pixel circuit configuration for a pixel.

[0017] FIG. 4B is a timing diagram for operating the pixel illustrated in FIG. 4A.

[0018] FIG. 5A is a circuit diagram for an exemplary pixel circuit configuration for a pixel.

[0019] FIG. 5B is a timing diagram for operating the pixel illustrated in FIG. 5A in a program phase and an emission phase.

[0020] FIG. 5C is a timing diagram for operating the pixel illustrated in FIG. 5A in a TFT monitor phase to measure aspects of the driving transistor.

[0021] FIG. 5D is a timing diagram for operating the pixel illustrated in FIG. 5A in an OLED monitor phase to measure aspects of the OLED.

[0022] FIG. 6A is a circuit diagram for an exemplary pixel circuit configuration for a pixel.

[0023] FIG. 6B is a timing diagram for operating the pixel 240 illustrated in FIG. 6A in a program phase and an emission phase.

[0024] FIG. 6C is a timing diagram for operating the pixel illustrated in FIG. 6A to monitor aspects of the driving transistor.

[0025] FIG. 6D is a timing diagram for operating the pixel illustrated in FIG. 6A to measure aspects of the OLED.

[0026] FIG. 7A is a circuit diagram for an exemplary pixel driving circuit for a pixel.

[0027] FIG. 7B is a timing diagram for operating the pixel illustrated in FIG. 7A in a program phase and an emission phase.

[0028] FIG. 7C is a timing diagram for operating the pixel illustrated in FIG. 7A in a TFT monitor phase to measure aspects of the driving transistor.

[0029] FIG. 7D is a timing diagram for operating the pixel illustrated in FIG. 7A in an OLED monitor phase to measure aspects of the OLED.

[0030] While the invention is susceptible to various modifications and alternative forms, specific embodiments have been shown by way of example in the drawings and will be described in detail herein. It should be understood, however, that the invention is not intended to be limited to the particular forms disclosed. Rather, the invention is to cover all modifications, equivalents, and alternatives falling within the spirit and scope of the invention as defined by the appended claims.

DETAILED DESCRIPTION

[0031] FIG. 1 is a diagram of an exemplary display system 50. The display system 50 includes an address driver 8, a data driver 4, a controller 2, a memory storage 6, and display panel 20. The display panel 20 includes an array of pixels 10 arranged in rows and columns. Each of the pixels 10 are individually programmable to emit light with individually programmable luminance values. The controller 2 receives digital data indicative of information to be displayed on the display panel 20. The controller 2 sends signals 32 to the data driver 4 and scheduling signals 34 to the address driver 8 to drive the pixels 10 in the display panel 20 to display the information indicated. The plurality of pixels 10 associated with the display panel 20 thus comprise a display array (“display screen”) adapted to dynamically display information according to the input digital data received by the controller 2. The display screen can display, for example, video information from a stream of video data received by the controller 2. The supply voltage 14 can provide a constant power voltage or can be an adjustable voltage supply that is controlled by signals from the controller 2. The display system 50 can also incorporate features from a current source or sink (not shown) to provide biasing currents to the pixels 10 in the display panel 20 to thereby decrease programming time for the pixels 10.

[0032] For illustrative purposes, the display system 50 in FIG. 1 is illustrated with only four pixels 10 in the display panel 20. It is understood that the display system 50 can be implemented with a display screen that includes an array of similar pixels, such as the pixels 10, and that the display screen is not limited to a particular number of rows and columns of pixels. For example, the display system 50 can be implemented with a display screen with a number of rows and columns of pixels commonly available in displays for mobile devices, monitor-based devices, and/or projection-devices.

[0033] The pixel 10 is operated by a driving circuit (“pixel circuit”) that generally includes a driving transistor and a light emitting device. Hereinafter the pixel 10 may refer to the pixel circuit. The light emitting device can optionally be an organic light emitting diode, but implementations of the present disclosure apply to pixel circuits having other electroluminescence devices, including current-driven light emitting devices. The driving transistor in the pixel 10 can optionally be an n-type or p-type amorphous silicon thin-film transistor, but implementations of the present disclosure are not limited to pixel circuits having a particular polarity of transistor or only to pixel circuits having thin-film transistors.

The pixel circuit 10 can also include a storage capacitor for storing programming information and allowing the pixel circuit 10 to drive the light emitting device after being addressed. Thus, the display panel 20 can be an active matrix display array.

[0034] As illustrated in FIG. 1, the pixel 10 illustrated as the top-left pixel in the display panel 20 is coupled to a select line 24j, a supply line 26j, a data line 22i, and a monitor line 28i. In an implementation, the supply voltage 14 can also provide a second supply line to the pixel 10. For example, each pixel can be coupled to a first supply line charged with V_{dd} and a second supply line coupled with V_{ss}, and the pixel circuits 10 can be situated between the first and second supply lines to facilitate driving current between the two supply lines during an emission phase of the pixel circuit. The top-left pixel 10 in the display panel 20 can correspond a pixel in the display panel in a “jth” row and “ith” column of the display panel 20. Similarly, the top-right pixel 10 in the display panel 20 represents a “jth” row and “mth” column; the bottom-left pixel 10 represents an “nth” row and “ith” column; and the bottom-right pixel 10 represents an “nth” row and “ith” column. Each of the pixels 10 is coupled to appropriate select lines (e.g., the select lines 24j and 24n), supply lines (e.g., the supply lines 26j and 26n), data lines (e.g., the data lines 22i and 22m), and monitor lines (e.g., the monitor lines 28i and 28m). It is noted that aspects of the present disclosure apply to pixels having additional connections, such as connections to additional select lines, and to pixels having fewer connections, such as pixels lacking a connection to a monitoring line.

[0035] With reference to the top-left pixel 10 shown in the display panel 20, the select line 24j is provided by the address driver 8, and can be utilized to enable, for example, a programming operation of the pixel 10 by activating a switch or transistor to allow the data line 22i to program the pixel 10. The data line 22i conveys programming information from the data driver 4 to the pixel 10. For example, the data line 22i can be utilized to apply a programming voltage or a programming current to the pixel 10 in order to program the pixel 10 to emit a desired amount of luminance. The programming voltage (or programming current) supplied by the data driver 4 via the data line 22i is a voltage (or current) appropriate to cause the pixel 10 to emit light with a desired amount of luminance according to the digital data received by the controller 2. The programming voltage (or programming current) can be applied to the pixel 10 during a programming operation of the pixel 10 so as to charge a storage device within the pixel 10, such as a storage capacitor, thereby enabling the pixel 10 to emit light with the desired amount of luminance during an emission operation following

the programming operation. For example, the storage device in the pixel 10 can be charged during a programming operation to apply a voltage to one or more of a gate or a source terminal of the driving transistor during the emission operation, thereby causing the driving transistor to convey the driving current through the light emitting device according to the voltage stored on the storage device.

[0036] Generally, in the pixel 10, the driving current that is conveyed through the light emitting device by the driving transistor during the emission operation of the pixel 10 is a current that is supplied by the first supply line 26j and is drained to a second supply line (not shown). The first supply line 22j and the second supply line are coupled to the voltage supply 14. The first supply line 26j can provide a positive supply voltage (e.g., the voltage commonly referred to in circuit design as “Vdd”) and the second supply line can provide a negative supply voltage (e.g., the voltage commonly referred to in circuit design as “Vss”). Implementations of the present disclosure can be realized where one or the other of the supply lines (e.g., the supply line 26j) are fixed at a ground voltage or at another reference voltage.

[0037] The display system 50 also includes a monitoring system 12. With reference again to the top left pixel 10 in the display panel 20, the monitor line 28i connects the pixel 10 to the monitoring system 12. The monitoring system 12 can be integrated with the data driver 4, or can be a separate stand-alone system. In particular, the monitoring system 12 can optionally be implemented by monitoring the current and/or voltage of the data line 22i during a monitoring operation of the pixel 10, and the monitor line 28i can be entirely omitted. Additionally, the display system 50 can be implemented without the monitoring system 12 or the monitor line 28i. The monitor line 28i allows the monitoring system 12 to measure a current or voltage associated with the pixel 10 and thereby extract information indicative of a degradation of the pixel 10. For example, the monitoring system 12 can extract, via the monitor line 28i, a current flowing through the driving transistor within the pixel 10 and thereby determine, based on the measured current and based on the voltages applied to the driving transistor during the measurement, a threshold voltage of the driving transistor or a shift thereof.

[0038] The monitoring system 12 can also extract an operating voltage of the light emitting device (e.g., a voltage drop across the light emitting device while the light emitting device is operating to emit light). The monitoring system 12 can then communicate the

signals 32 to the controller 2 and/or the memory 6 to allow the display system 50 to store the extracted degradation information in the memory 6. During subsequent programming and/or emission operations of the pixel 10, the degradation information is retrieved from the memory 6 by the controller 2 via the memory signals 36, and the controller 2 then compensates for the extracted degradation information in subsequent programming and/or emission operations of the pixel 10. For example, once the degradation information is extracted, the programming information conveyed to the pixel 10 via the data line 22i can be appropriately adjusted during a subsequent programming operation of the pixel 10 such that the pixel 10 emits light with a desired amount of luminance that is independent of the degradation of the pixel 10. In an example, an increase in the threshold voltage of the driving transistor within the pixel 10 can be compensated for by appropriately increasing the programming voltage applied to the pixel 10.

[0039] FIG. 2A is a circuit diagram of an exemplary driving circuit for a pixel 100. The driving circuit shown in FIG. 1A is utilized to program, monitor, and drive the pixel 100 and includes a driving transistor 114 for conveying a driving current through an organic light emitting diode (“OLED”) 110. The OLED 110 emits light according to the current passing through the OLED 110, and can be replaced by any current-driven light emitting device. The pixel 100 can be utilized in the display panel 20 of the display system 50 described in connection with FIG. 1.

[0040] The driving circuit for the pixel 100 also includes a storage capacitor 118, a switching transistor 116, and a data switching transistor 112. The pixel 100 is coupled to a reference voltage line 102, a select line 104, a voltage supply line 106, and a data/monitor line 108. The driving transistor 114 draws a current from the voltage supply line 106 according to a gate-source voltage (“V_{gs}”) across a gate terminal of the driving transistor 114 and a source terminal of the driving transistor 114. For example, in a saturation mode of the driving transistor 114, the current passing through the driving transistor can be given by $I_{ds} = \beta (V_{gs} - V_t)^2$, where β is a parameter that depends on device characteristics of the driving transistor 114, I_{ds} is the current from the drain terminal of the driving transistor 114 to the source terminal of the driving transistor 114, and V_t is a threshold voltage of the driving transistor 114.

[0041] In the pixel 100, the storage capacitor 118 is coupled across the gate terminal and the source terminal of the driving transistor 114. The storage capacitor 118 has a first terminal 118g, which is referred to for convenience as a gate-side terminal 118g, and a second terminal 118s, which is referred to for convenience as a source-side terminal 118s. The gate-side terminal 118g of the storage capacitor 118 is electrically coupled to the gate terminal of the driving transistor 114. The source-side terminal 118s of the storage capacitor 118 is electrically coupled to the source terminal of the driving transistor 114. Thus, the gate-source voltage V_{gs} of the driving transistor 114 is also the voltage charged on the storage capacitor 118. As will be explained further below, the storage capacitor 118 can thereby maintain a driving voltage across the driving transistor 114 during an emission phase of the pixel 100.

[0042] The drain terminal of the driving transistor 114 is electrically coupled to the voltage supply line 106. The source terminal of the driving transistor 114 is electrically coupled to an anode terminal of the OLED 110. A cathode terminal of the OLED 110 can be connected to ground or can optionally be connected to a second voltage supply line, such as a supply line V_{ss} . Thus, the OLED 110 is connected in series with the current path of the driving transistor 114. The OLED 110 emits light according to the current passing through the OLED 110 once a voltage drop across the anode and cathode terminals of the OLED achieves an operating voltage (" V_{OLED} ") of the OLED 110. That is, when the difference between the voltage on the anode terminal and the voltage on the cathode terminal is greater than the operating voltage V_{OLED} , the OLED 110 turns on and emits light. When the anode to cathode voltage is less than V_{OLED} , current does not pass through the OLED 110.

[0043] The switching transistor 116 is operated according to a select line 104 (e.g., when the select line 104 is at a high level, the switching transistor 116 is turned on, and when the select line 104 is at a low level, the switching transistor is turned off). When turned on, the switching transistor 116 electrically couples the gate terminal of the driving transistor (and the gate-side terminal 118g of the storage capacitor 118) to the reference voltage line 102. As will be described further below in connection with FIG. 1B, the reference voltage line 102 can be maintained at a ground voltage or another fixed reference voltage (" V_{ref} ") and can optionally be adjusted during a programming phase of the pixel 100 to provide compensation for degradation of the pixel 100. The data switching transistor 112 is operated by the select line 104 in the same manner as the switching transistor 116. Although, it is

noted that the data switching transistor 112 can optionally be operated by a second select line in an implementation of the pixel 100. When turned on, the data switching transistor 112 electrically couples the source terminal of the driving transistor (and the source-side terminal 118s of the storage capacitor 118) to the data/monitor line 108.

[0044] FIG. 2B is a schematic timing diagram of exemplary operation cycles for the pixel 100 shown in FIG. 2A. The pixel 100 can be operated in a monitor phase 121, a program phase 122, and an emission phase 123. During the monitor phase 121, the select line 104 is high and the switching transistor 116 and the data switching transistor 112 are both turned on. The data/monitor line 108 is fixed at a calibration voltage (“Vcal”). Because the data switching transistor 112 is turned on, the calibration voltage Vcal is applied to the anode terminal of the OLED 110. The value of Vcal is chosen such that the voltage applied across the anode and cathode terminals of the OLED 110 is less than the operating voltage V_{OLED} of the OLED 110, and the OLED 110 therefore does not draw current. By setting Vcal at a level sufficient to turn off the OLED 110 (i.e., sufficient to ensure that the OLED 110 does not draw current), the current flowing through the driving transistor 114 during the monitor phase 121 does not pass through the OLED 110 and instead travels through the data/monitor line 108. Thus, by fixing the data/monitor line 108 at Vcal during the monitor phase 121, the current on the data/monitor line 108 is the current being drawn through the driving transistor 114. The data/monitor line 108 can then be coupled to a monitoring system (such as the monitoring system 12 shown in FIG. 1) to measure the current during the monitor phase 121 and thereby extract information indicative of a degradation of the pixel 100. For example, by analyzing the current measured on the data/monitor line 108 during the monitor phase 121 with a reference current value, the threshold voltage (“Vt”) of the driving transistor can be determined. Such a determination of the threshold voltage can be carried out by comparing the measured current with an expected current based on the values of the reference voltage Vref and the calibration voltage Vcal applied to the gate and source terminals, respectively, of the driving transistor 114. For example, the relationship

$$I_{\text{meas}} = I_{\text{ds}} = \beta (V_{\text{gs}} - V_{\text{t}})^2 = \beta (V_{\text{ref}} - V_{\text{cal}} - V_{\text{t}})^2$$

can be rearranged to yield

$$V_{\text{t}} = V_{\text{ref}} - V_{\text{cal}} - (I_{\text{meas}} / \beta)^{1/2}$$

[0045] Additionally or alternatively, degradation of the pixel 100 (e.g., the value of V_t) can be extracted according to a stepwise method wherein a comparison is made between I_{meas} and an expected current and an estimate of the value of I_{meas} is updated incrementally according to the comparison (e.g., based on determining whether I_{meas} is lesser than, or greater than, the expected current). It is noted that while the above description describes measuring the current on the data/monitor line 108 during the monitor phase 121, the monitor phase 121 can include measuring a voltage on the data/monitor line 108 while fixing the current on the data/monitor line 108. Furthermore, the monitor phase 121 can include indirectly measuring the current on the data/monitor line 108 by, for example, measuring a voltage drop across a load, measuring a current related to the current on the data/monitor line 108 provided via a current conveyor, or by measuring a voltage output from a current controlled voltage source that receives the current on the data/monitor line 108.

[0046] During the programming phase 122, the select line 104 remains high, and the switching transistor 116 and the data switching transistor 112 therefore remain turned on. The reference voltage line 102 can remain fixed at V_{ref} or can optionally be adjusted by a compensation voltage (" V_{comp} ") appropriate to account for degradation of the pixel 100, such as the degradation determined during the monitor phase 121. For example, V_{comp} can be a voltage sufficient to account for a shift in the threshold voltage V_t of the driving transistor 114. The voltage V_{ref} (or V_{comp}) is applied to the gate-side terminal 118g of the storage capacitor 118. Also during the program phase 122, the data/monitor line 108 is adjusted to a programming voltage (" V_{prog} "), which is applied to the source-side terminal 118s of the storage capacitor 118. During the program phase 122, the storage capacitor 118 is charged with a voltage given by the difference of V_{ref} (or V_{comp}) on the reference voltage line 102 and V_{prog} on the data/monitor line 108.

[0047] According to an aspect of the present disclosure, degradation of the pixel 100 is compensated for by applying the compensation voltage V_{comp} to the gate-side terminal 118g of the storage capacitor 118 during the program phase 122. As the pixel 100 degrades due to, for example, mechanical stresses, aging, temperature variations, etc. the threshold voltage V_t of the driving transistor 114 can shift (e.g., increase) and therefore a larger gate-source voltage V_{gs} is required across the driving transistor 114 to maintain a desired driving current through the OLED 110. In implementations, the shift in V_t can first be measured, during the monitor phase 121, via the data/monitor line 108, and then the shift in V_t can be

compensated for, during the program phase 122, by applying a compensation voltage V_{comp} separate from a programming voltage V_{prog} to the gate-side terminal 118g of the storage capacitor 118. Additionally or alternatively, compensation can be provided via adjustments to the programming voltage V_{prog} applied to the source-side terminal 118s of the storage capacitor 118. Furthermore, the programming voltage V_{prog} is preferably a voltage sufficient to turn off the OLED 110 during the program phase 122 such that the OLED 110 is prevented from emitting light during the program phase 122.

[0048] During the emission phase 123 of the pixel 100, the select line 104 is low, and the switching transistor 116 and the data switching transistor 112 are both turned off. The storage capacitor 118 remains charged with the driving voltage given by the difference of V_{ref} (or V_{comp}) and V_{prog} applied across the storage capacitor 118 during the program phase 122. After the switching transistor 116 and the data switching transistor 112 are turned off, the storage capacitor 118 maintains the driving voltage and the driving transistor 114 draws a driving current from the voltage supply line 106. The driving current is then conveyed through the OLED 110 which emits light according to the amount of current passed through the OLED 110. During the emission phase 123, the anode terminal of the OLED 110 (and the source-side terminal 118s of the storage capacitor) can change from the program voltage V_{prog} applied during the program phase 122 to an operating voltage V_{OLED} of the OLED 110. Furthermore, as the driving current is passed through the OLED 110, the anode terminal of the OLED 110 can change (e.g., increase) over the course of the emission phase 123. However, during the emission phase 123, the storage capacitor 118 self-adjusts the voltage on the gate terminal of the driving transistor 114 to maintain the gate-source voltage of the driving transistor 114 even as the voltage on the anode of the OLED 110 may change. For example, adjustments (e.g., increases) on the source-side terminal 118s are reflected on the gate-side terminal 118g so as to maintain the driving voltage that was charged on the storage capacitor 118 during the program phase 122.

[0049] While the driving circuit illustrated in FIG. 2A is illustrated with n-type transistors, which can be thin-film transistors and can be formed from amorphous silicon, the driving circuit illustrated in FIG. 2A and the operating cycles illustrated in FIG. 2B can be extended to a complementary circuit having one or more p-type transistors and having transistors other than thin film transistors.

[0050] FIG. 3A is a circuit diagram for an exemplary pixel circuit configuration for a pixel 130. The driving circuit for the pixel 130 is utilized to program, monitor, and drive the pixel 130. The pixel 130 includes a driving transistor 148 for conveying a driving current through an OLED 146. The OLED 146 is similar to the OLED 110 shown in FIG. 2A and emits light according to the current passing through the OLED 146. The OLED 146 can be replaced by any current-driven light emitting device. The pixel 130 can be utilized in the display panel 20 of the display system 50 described in connection with FIG. 1, with appropriate modifications to include the connection lines described in connection with the pixel 130.

[0051] The driving circuit for the pixel 130 also includes a storage capacitor 156, a first switching transistor 152, and a second switching transistor 154, a data switching transistor 144, and an emission transistor 150. The pixel 130 is coupled to a reference voltage line 140, a data/reference line 132, a voltage supply line 136, a data/monitor line 138, a select line 134, and an emission line 142. The driving transistor 148 draws a current from the voltage supply line 136 according to a gate-source voltage (“ V_{gs} ”) across a gate terminal of the driving transistor 148 and a source terminal of the driving transistor 148, and a threshold voltage (“ V_t ”) of the driving transistor 148. The relationship between the drain-source current and the gate-source voltage of the driving transistor 148 is similar to the operation of the driving transistor 114 described in connection with FIGS. 2A and 2B.

[0052] In the pixel 130, the storage capacitor 156 is coupled across the gate terminal and the source terminal of the driving transistor 148 through the emission transistor 150. The storage capacitor 156 has a first terminal 156g, which is referred to for convenience as a gate-side terminal 156g, and a second terminal 156s, which is referred to for convenience as a source-side terminal 156s. The gate-side terminal 156g of the storage capacitor 156 is electrically coupled to the gate terminal of the driving transistor 148 through the emission transistor 150. The source-side terminal 156s of the storage capacitor 156 is electrically coupled to the source terminal of the driving transistor 148. Thus, when the emission transistor 150 is turned on, the gate-source voltage V_{gs} of the driving transistor 148 is the voltage charged on the storage capacitor 156. The emission transistor 150 is operated according to the emission line 142 (e.g., the emission transistor 150 is turned on when the emission line 142 is set high and vice versa). As will be explained further below, the storage

capacitor 156 can thereby maintain a driving voltage across the driving transistor 148 during an emission phase of the pixel 130.

[0053] The drain terminal of the driving transistor 148 is electrically coupled to the voltage supply line 136. The source terminal of the driving transistor 148 is electrically coupled to an anode terminal of the OLED 146. A cathode terminal of the OLED 146 can be connected to ground or can optionally be connected to a second voltage supply line, such as a supply line V_{ss} . Thus, the OLED 146 is connected in series with the current path of the driving transistor 148. The OLED 146 emits light according to the current passing through the OLED 146 once a voltage drop across the anode and cathode terminals of the OLED 146 achieves an operating voltage (" V_{OLED} ") of the OLED 146 similar to the description of the OLED 110 provided in connection with FIGS. 2A and 2B.

[0054] The first switching transistor 152, the second switching transistor 154, and the data switching transistor 144 are each operated according to the select line 134 (e.g., when the select line 134 is at a high level, the transistors 144, 152, 154 are turned on, and when the select line 134 is at a low level, the switching transistors 144, 152, 154 are turned off). When turned on, the first switching transistor 152 electrically couples the gate terminal of the driving transistor 148 to the reference voltage line 140. As will be described further below in connection with FIG. 3B, the reference voltage line 140 can be maintained at a fixed first reference voltage (" V_{ref1} "). The data switching transistor 144 and/or the second switching transistor 154 can optionally be operated by a second select line in an implementation of the pixel 130. When turned on, the second switching transistor 154 electrically couples the gate-side terminal 156g of the storage capacitor 156 to the data/reference line 132. When turned on, the data switching transistor 144 electrically couples the data/monitor line 138 to the source-side terminal 156s of the storage capacitor 156.

[0055] FIG. 3B is a timing diagram for operating the pixel 130 illustrated in FIG. 3A. As shown in FIG. 3B, the pixel 130 can be operated in a monitor phase 124, a program phase 125, and an emission phase 126.

[0056] During the monitor phase 124 of the pixel 130, the select line 134 is set high while the emission line 142 is set low. The first switching transistor 152, the second switching transistor 154, and the data switching transistor 144 are all turned on while the emission transistor 150 is turned off. The data/monitor line 138 is fixed at a calibration voltage (" V_{cal} "), and the reference voltage line 140 is fixed at the first reference voltage

Vref1. The reference voltage line 140 applies the first reference voltage Vref1 to the gate terminal of the driving transistor 148 through the first switching transistor 152, and the data/monitor line 138 applies the calibration voltage Vcal to the source terminal of the driving transistor 148 through the data switching transistor 144. The first reference voltage Vref1 and the calibration voltage Vcal thus fix the gate-source potential Vgs of the driving transistor 148. The driving transistor 148 draws a current from the voltage supply line 136 according to the gate-source potential difference thus defined. The calibration voltage Vcal is also applied to the anode of the OLED 146 and is advantageously selected to be a voltage sufficient to turn off the OLED 146. For example, the calibration voltage Vcal can cause the voltage drop across the anode and cathode terminals of the OLED 146 to be less than the operating voltage V_{OLED} of the OLED 146. By turning off the OLED 146, the current through the driving transistor 148 is directed entirely to the data/monitor line 138 rather than through the OLED 146. Similar to the description of the monitoring phase 121 in connection with the pixel 100 in FIGS. 2A and 2B, the current measured on the data/monitor line 138 of the pixel 130 can be used to extract degradation information for the pixel 130, such as information indicative of the threshold voltage V_t of the driving transistor 148.

[0057] During the program phase 125, the select line 134 is set high and the emission line 142 is set low. Similar to the monitor phase 124, the first switching transistor 152, the second switching transistor 154, and the data switching transistor 144 are all turned on while the emission transistor 150 is turned off. The data/monitor line 138 is set to a program voltage (“Vprog”), the reference voltage line 140 is fixed at the first reference voltage Vref1, and the data/reference line 132 is set to a second reference voltage (“Vref2”). During the program phase 125, the second reference voltage Vref2 is thus applied to the gate-side terminal 156g of the storage capacitor 156 while the program voltage Vprog is applied to the source-side terminal 156s of the storage capacitor 156. In an implementation, the data/reference line 132 can be set (adjusted) to a compensation voltage (“Vcomp”) rather than remain fixed at the second reference voltage Vref2 during the program phase 125. The storage capacitor 156 is then charged according to the difference between the second reference voltage Vref2 (or the compensation voltage Vcomp) and the program voltage Vprog. Implementations of the present disclosure also include operations of the program phase 125 where the program voltage Vprog is applied to the data/reference line 132, while the data/monitor line 138 is fixed at a second reference voltage Vref2, or at a compensation

voltage V_{comp} . In either operation, the storage capacitor 156 is charged with a voltage given by the difference of V_{prog} and V_{ref2} (or V_{comp}). Similar to the operation of the pixel 100 described in connection with FIGS. 2A and 2B, the compensation voltage V_{comp} applied to the gate-side terminal 156g is a proper voltage to account for a degradation of the pixel circuit 130, such as the degradation measured during the monitor phase 124 (e.g., an increase in the threshold voltage V_t of the driving transistor 148).

[0058] The program voltage V_{prog} is applied to the anode terminal of the OLED 146 during the program phase 125. The program voltage V_{prog} is advantageously selected to be sufficient to turn off the OLED 146 during the program phase 125. For example, the program voltage V_{prog} can advantageously cause the voltage drop across the anode and cathode terminals of the OLED 146 to be less than the operating voltage V_{OLED} of the OLED 146. Additionally or alternatively, in implementations where the second reference voltage V_{ref2} is applied to the data/monitor line 138, the second reference voltage V_{ref2} can be selected to be a voltage that maintains the OLED 146 in an off state.

[0059] During the program phase 125, the driving transistor 148 is advantageously isolated from the storage capacitor 156 while the storage capacitor 156 receives the programming information via the data/reference line 132 and/or the data/monitor line 138. By isolating the driving transistor 148 from the storage capacitor 156 with the emission transistor 150, which is turned off during the program phase 125, the driving transistor 148 is advantageously prevented from turning on during the program phase 125. The pixel circuit 100 in FIG. 2A provides an example of a circuit lacking a means to isolate the driving transistor 114 from the storage capacitor 118 during the program phase 122. By way of example, in the pixel 100, during the program phase 122, a voltage is established across the storage capacitor sufficient to turn on the driving transistor 114. Once the voltage on the storage capacitor 118 is sufficient, the driving transistor 114 begins drawing current from the voltage supply line 106. The current does not flow through the OLED 110, which is reverse biased during the program phase 122, instead the current from the driving transistor 114 flows through the data switching transistor 112. A voltage drop is therefore developed across the data switching transistor 112 due to the non-zero resistance of the data switching transistor 112 as the current is conveyed through the data switching transistor 112. The voltage drop across the data switching transistor 112 causes the voltage that is applied to the source-side terminal 118s of the storage capacitor 118 to be different from the program

voltage V_{prog} on the data/monitor line 108. The difference is given by the current flowing through the data switching transistor 112 and the inherent resistance of the data switching transistor 112.

[0060] Referring again to FIGS. 3A and 3B, the emission transistor 150 of the pixel 130 addresses the above-described effect by ensuring that the voltage established on the storage capacitor 156 during the program phase 125 is not applied across the gate-source terminals of the driving transistor 148 during the program phase 125. The emission transistor 150 disconnects one of the terminals of the storage capacitor 156 from the driving transistor 148 to ensure that the driving transistor is not turned on during the program phase 125 of the pixel 130. The emission transistor 150 allows for programming the pixel circuit 130 (e.g., charging the storage capacitor 156) with a voltage that is independent of a resistance of the switching transistor 144. Furthermore, the first reference voltage V_{ref1} applied to the reference voltage line 140 can be selected such that the gate-source voltage given by the difference between V_{ref1} and V_{prog} is sufficient to prevent the driving transistor 148 from switching on during the program phase 125.

[0061] During the emission phase 126 of the pixel 130, the select line 134 is set low while the emission line 142 is high. The first switching transistor 152, the second switching transistor 154, and the data switching transistor 144 are all turned off. The emission transistor 150 is turned on during the emission phase 126. By turning on the emission transistor 150, the storage capacitor 156 is connected across the gate terminal and the source terminal of the driving transistor 148. The driving transistor 148 draws a driving current from the voltage supply line 136 according to driving voltage stored on the storage capacitor 156 and applied across the gate and source terminals of the driving transistor 148. The anode terminal of the OLED 146 is no longer set to a program voltage by the data/monitor line 138 because the data switching transistor 144 is turned off, and so the OLED 146 is turned on and the voltage at the anode terminal of the OLED 146 adjusts to the operating voltage V_{OLED} of the OLED 146. The storage capacitor 156 maintains the driving voltage charged on the storage capacitor 156 by self-adjusting the voltage of the source terminal and/or gate terminal of the driving transistor 148 so as to account for variations on one or the other. For example, if the voltage on the source-side terminal 156s changes during the emission cycle 126 due to, for example, the anode terminal of the OLED 146 settling at the operating voltage V_{OLED} , the storage capacitor 156 adjusts the voltage on the gate terminal of the driving transistor 148 to

maintain the driving voltage across the gate and source terminals of the driving transistor 148.

[0062] While the driving circuit illustrated in FIG. 3A is illustrated with n-type transistors, which can be thin-film transistors and can be formed from amorphous silicon, the driving circuit illustrated in FIG. 3A for the pixel 130 and the operating cycles illustrated in FIG. 3B can be extended to a complementary circuit having one or more p-type transistors and having transistors other than thin film transistors.

[0063] FIG. 4A is a circuit diagram for an exemplary pixel circuit configuration for a pixel 160. The driving circuit for the pixel 160 is utilized to program, monitor, and drive the pixel 160. The pixel 160 includes a driving transistor 174 for conveying a driving current through an OLED 172. The OLED 172 is similar to the OLED 110 shown in FIG. 1A and emits light according to the current passing through the OLED 172. The OLED 172 can be replaced by any current-driven light emitting device. The pixel 160 can be utilized in the display panel 20 of the display system 50 described in connection with FIG. 1, with appropriate connection lines to the data driver, address driver, etc.

[0064] The driving circuit for the pixel 160 also includes a storage capacitor 182, a data switching transistor 180, a monitor transistor 178, and an emission transistor 176. The pixel 160 is coupled to a data line 162, a voltage supply line 166, a monitor line 168, a select line 164, and an emission line 170. The driving transistor 174 draws a current from the voltage supply line 166 according to a gate-source voltage (“ V_{gs} ”) across a gate terminal of the driving transistor 174 and a source terminal of the driving transistor 174, and a threshold voltage (“ V_t ”) of the driving transistor 174. The relationship between the drain-source current and the gate-source voltage of the driving transistor 174 is similar to the operation of the driving transistor 114 described in connection with FIGS. 2A and 2B.

[0065] In the pixel 160, the storage capacitor 182 is coupled across the gate terminal and the source terminal of the driving transistor 174 through the emission transistor 176. The storage capacitor 182 has a first terminal 182g, which is referred to for convenience as a gate-side terminal 182g, and a second terminal 182s, which is referred to for convenience as a source-side terminal 182s. The gate-side terminal 182g of the storage capacitor 182 is electrically coupled to the gate terminal of the driving transistor 174. The source-side terminal 182s of the storage capacitor 182 is electrically coupled to the source terminal of the driving transistor 174 through the emission transistor 176. Thus, when the emission

transistor 176 is turned on, the gate-source voltage V_{gs} of the driving transistor 174 is the voltage charged on the storage capacitor 182. The emission transistor 176 is operated according to the emission line 170 (e.g., the emission transistor 176 is turned on when the emission line 170 is set high and vice versa). As will be explained further below, the storage capacitor 182 can thereby maintain a driving voltage across the driving transistor 174 during an emission phase of the pixel 160.

[0066] The drain terminal of the driving transistor 174 is electrically coupled to the voltage supply line 166. The source terminal of the driving transistor 174 is electrically coupled to an anode terminal of the OLED 172. A cathode terminal of the OLED 172 can be connected to ground or can optionally be connected to a second voltage supply line, such as a supply line V_{ss} . Thus, the OLED 172 is connected in series with the current path of the driving transistor 174. The OLED 172 emits light according to the current passing through the OLED 172 once a voltage drop across the anode and cathode terminals of the OLED 172 achieves an operating voltage (" V_{OLED} ") of the OLED 172 similar to the description of the OLED 110 provided in connection with FIGS. 2A and 2B.

[0067] The data switching transistor 180 and the monitor transistor 178 are each operated according to the select line 168 (e.g., when the select line 168 is at a high level, the transistors 178, 180 are turned on, and when the select line 168 is at a low level, the transistors 178, 180 are turned off). When turned on, the data switching transistor 180 electrically couples the gate terminal of the driving transistor 174 to the data line 162. The data switching transistor 180 and/or the monitor transistor 178 can optionally be operated by a second select line in an implementation of the pixel 160. When turned on, the monitor transistor 178 electrically couples the source-side terminal 182s of the storage capacitor 182 to the monitor line 164. When turned on, the data switching transistor 180 electrically couples the data line 162 to the gate-side terminal 182g of the storage capacitor 182.

[0068] FIG. 4B is a timing diagram for operating the pixel 160 illustrated in FIG. 4A. As shown in FIG. 4B, the pixel 160 can be operated in a monitor phase 127, a program phase 128, and an emission phase 129.

[0069] During the monitor phase 127 of the pixel 160, the select line 164 and the emission line 170 are both set high. The data switching transistor 180, the monitor transistor 178, and the emission transistor 170 are all turned on. The data line 162 is fixed at a first calibration voltage (" V_{call} "), and the monitor line 168 is fixed at a second calibration

voltage (“Vcal2”). The first calibration voltage Vcal1 is applied to the gate terminal of the driving transistor 174 through the data switching transistor 180. The second calibration voltage Vcal2 is applied to the source terminal of the driving transistor 174 through the monitor transistor 178 and the emission transistor 176. The first calibration voltage Vcal1 and the second calibration voltage Vcal2 thereby fix the gate-source potential Vgs of the driving transistor 174 and the driving transistor 174 draws a current from the voltage supply line 166 according to its gate-source potential Vgs. The second calibration voltage Vcal2 is also applied to the anode of the OLED 172 and is advantageously selected to be a voltage sufficient to turn off the OLED 172. Turning off the OLED 172 during the monitor phase 127 ensures that the current flowing through the driving transistor 174 does not pass through the OLED 174 and instead is conveyed to the monitor line 168 via the emission transistor 176 and the monitor transistor 178. Similar to the description of the monitoring phase 121 in connection with the pixel 100 in FIGS. 2A and 2B, the current measured on the monitor line 168 can be used to extract degradation information for the pixel 160, such as information indicative of the threshold voltage Vt of the driving transistor 174.

[0070] During the program phase 128, the select line 164 is set high and the emission line 170 is set low. The data switching transistor 180 and the monitor transistor 178 are turned on while the emission transistor 176 is turned off. The data line 162 is set to a program voltage (“Vprog”) and the monitor line 168 is fixed at a reference voltage (“Vref”). The monitor line 164 can optionally be set to a compensation voltage (“Vcomp”) rather than the reference voltage Vref. The gate-side terminal 182g of the storage capacitor 182 is set to the program voltage Vprog and the source-side terminal 182s is set to the reference voltage Vref (or the compensation voltage Vcomp). The storage capacitor 182 is thereby charged according to the difference between the program voltage Vprog and the reference voltage Vref (or the compensation voltage Vcomp). The voltage charged on the storage capacitor 182 during the program phase 128 is referred to as a driving voltage. The driving voltage is a voltage appropriate to be applied across the driving transistor 174 to generate a desired driving current that will cause the OLED 172 to emit a desired amount of light. Similar to the operation of the pixel 100 in connection with FIGS. 2A and 2B, the compensation voltage Vcomp optionally applied to the source-side terminal 182s is a proper voltage to account for a degradation of the pixel circuit 160, such as the degradation measured during the monitor phase 127 (e.g., an increase in the threshold voltage Vt of the driving transistor 174).

Additionally or alternatively, compensation for degradation of the pixel 160 can be accounted for by adjustments to the program voltage V_{prog} applied to the gate-side terminal 182g.

[0071] During the program phase 128, the driving transistor 174 is isolated from the storage capacitor 182 by the emission transistor 176, which disconnects the source terminal of the driving transistor 174 from the storage capacitor 182 during the program phase 128. Similar, to the description of the operation of the emission transistor 150 in connection with FIGS. 3A and 3B, isolating the driving transistor 174 and the storage capacitor 182 during the program phase 128 advantageously prevents the driving transistor 182 from turning on during the program phase 128. By preventing the driving transistor 174 from turning on, the voltage applied to the storage capacitor 182 during the program phase 128 is advantageously independent of a resistance of the switching transistors as no current is conveyed through the switching transistors. In the configuration in pixel 160, the emission transistor 176 also advantageously disconnects the storage capacitor 182 from the OLED 172 during the program phase 128, which prevents the storage capacitor 182 from being influenced by an internal capacitance of the OLED 172 during the program phase 128.

[0072] During the emission phase 129 of the pixel 160, the select line 164 is set low while the emission line 170 is high. The data switching transistor 180 and the monitor transistor 178 are turned off and the emission transistor 176 is turned on during the emission phase 129. By turning on the emission transistor 176, the storage capacitor 182 is connected across the gate terminal and the source terminal of the driving transistor 174. The driving transistor 174 draws a driving current from the voltage supply line 166 according to the driving voltage stored on the storage capacitor 182. The OLED 172 is turned on and the voltage at the anode terminal of the OLED 172 adjusts to the operating voltage V_{OLED} of the OLED 172. The storage capacitor 182 maintains the driving voltage by self-adjusting the voltage of the source terminal and/or gate terminal of the driving transistor 174 so as to account for variations on one or the other. For example, if the voltage on the source-side terminal 182s changes during the emission cycle 129 due to, for example, the anode terminal of the OLED 172 settling at the operating voltage V_{OLED} , the storage capacitor 182 adjusts the voltage on the gate terminal of the driving transistor 174 to maintain the driving voltage across the gate and source terminals of the driving transistor 174.

[0073] While the driving circuit illustrated in FIG. 4A is illustrated with n-type transistors, which can be thin-film transistors and can be formed from amorphous silicon, the

driving circuit illustrated in FIG. 4A for the pixel 160 and the operating cycles illustrated in FIG. 4B can be extended to a complementary circuit having one or more p-type transistors and having transistors other than thin film transistors.

[0074] FIG. 5A is a circuit diagram for an exemplary pixel circuit configuration for a pixel 200. The driving circuit for the pixel 200 is utilized to program, monitor, and drive the pixel 200. The pixel 200 includes a driving transistor 214 for conveying a driving current through an OLED 220. The OLED 220 is similar to the OLED 110 shown in FIG. 2A and emits light according to the current passing through the OLED 220. The OLED 220 can be replaced by any current-driven light emitting device. The pixel 200 can be incorporated into the display panel 20 and the display system 50 described in connection with FIG. 1, with appropriate line connections to the data driver, address driver, monitoring system, etc.

[0075] The driving circuit for the pixel 200 also includes a storage capacitor 218, a data switching transistor 216, a monitor transistor 212, and an emission transistor 222. The pixel 200 is coupled to a data line 202, a voltage supply line 206, a monitor line 208, a select line 204, and an emission line 210. The driving transistor 214 draws a current from the voltage supply line 206 according to a gate-source voltage (“ V_{gs} ”) across a gate terminal of the driving transistor 214 and a source terminal of the driving transistor 214, and a threshold voltage (“ V_t ”) of the driving transistor 214. The relationship between the drain-source current and the gate-source voltage of the driving transistor 214 is similar to the operation of the driving transistor 114 described in connection with FIGS. 2A and 2B.

[0076] In the pixel 200, the storage capacitor 218 is coupled across the gate terminal and the source terminal of the driving transistor 214 through the emission transistor 222. The storage capacitor 218 has a first terminal 218g, which is referred to for convenience as a gate-side terminal 218g, and a second terminal 218s, which is referred to for convenience as a source-side terminal 218s. The gate-side terminal 218g of the storage capacitor 218 is electrically coupled to the gate terminal of the driving transistor 214. The source-side terminal 218s of the storage capacitor 218 is electrically coupled to the source terminal of the driving transistor 214 through the emission transistor 222. Thus, when the emission transistor 222 is turned on, the gate-source voltage V_{gs} of the driving transistor 214 is the voltage charged on the storage capacitor 218. The emission transistor 222 is operated according to the emission line 210 (e.g., the emission transistor 222 is turned on when the emission line 210 is set high and vice versa). As will be explained further below, the storage

capacitor 218 can thereby maintain a driving voltage across the driving transistor 214 during an emission phase of the pixel 200.

[0077] The drain terminal of the driving transistor 214 is electrically coupled to the voltage supply line 206. The source terminal of the driving transistor 214 is electrically coupled to an anode terminal of the OLED 220 through the emission transistor 222. A cathode terminal of the OLED 220 can be connected to ground or can optionally be connected to a second voltage supply line, such as a supply line V_{ss}. Thus, the OLED 220 is connected in series with the current path of the driving transistor 214. The OLED 220 emits light according to the current passing through the OLED 220 once a voltage drop across the anode and cathode terminals of the OLED 220 achieves an operating voltage (“V_{OLED}”) of the OLED 220 similar to the description of the OLED 110 provided in connection with FIGS. 2A and 2B.

[0078] The data switching transistor 216 and the monitor transistor 212 are each operated according to the select line 204 (e.g., when the select line 204 is at a high level, the transistors 212, 216 are turned on, and when the select line 204 is at a low level, the transistors 212, 216 are turned off). When turned on, the data switching transistor 216 electrically couples the gate terminal of the driving transistor 214 to the data line 202. The data switching transistor 216 and/or the monitor transistor 212 can optionally be operated by a second select line in an implementation of the pixel 200. When turned on, the monitor transistor 212 electrically couples the source-side terminal 218s of the storage capacitor 218 to the monitor line 208. When turned on, the data switching transistor 216 electrically couples the data line 202 to the gate-side terminal 218g of the storage capacitor 218.

[0079] FIG. 5B is a timing diagram for operating the pixel 200 illustrated in FIG. 5A in a program phase and an emission phase. As shown in FIG. 5B, the pixel 200 can be operated in a program phase 223, and an emission phase 224. FIG. 5C is a timing diagram for operating the pixel 200 illustrated in FIG. 5A in a TFT monitor phase 225 to measure aspects of the driving transistor 214. FIG. 5D is a timing diagram for operating the pixel 200 illustrated in FIG. 5A in an OLED monitor phase 226 to measure aspects of the OLED 220.

[0080] In an exemplary implementation for operating (“driving”) the pixel 200, the pixel 200 may be operated with a program phase 223 and an emission phase 224 for each frame of a video display. The pixel 200 may also optionally be operated in either or both of the monitor phases 225, 226 to monitor degradation of the pixel 200 due to the driving

transistor 214 or of the OLED 220, or both. The pixel 200 may be operated in the monitor phase(s) 225, 226 intermittently, periodically, or according to a sorting and prioritization algorithm to dynamically determine and identify pixels in a display that require updated degradation information for providing compensation therefore. Therefore, a driving sequence corresponding to a single frame being displayed via the pixel 200 can include the program phase 223 and the emission phase 224, and can optionally either or both of the monitor phases 225, 226.

[0081] During the program phase 223, the select line 204 is set high and the emission line 210 is set low. The data switching transistor 216 and the monitor transistor 212 are turned on while the emission transistor 222 is turned off. The data line 202 is set to a program voltage (“Vprog”) and the monitor line 208 is fixed at a reference voltage (“Vref”). The monitor line 208 can optionally be set to a compensation voltage (“Vcomp”) rather than the reference voltage Vref. The gate-side terminal 218g of the storage capacitor 218 is set to the program voltage Vprog and the source-side terminal 218s is set to the reference voltage Vref (or the compensation voltage Vcomp). The storage capacitor 218 is thereby charged according to the difference between the program voltage Vprog and the reference voltage Vref (or the compensation voltage Vcomp). The voltage charged on the storage capacitor 218 during the program phase 223 is referred to as a driving voltage. The driving voltage is a voltage appropriate to be applied across the driving transistor to generate a desired driving current that will cause the OLED 220 to emit a desired amount of light. Similar to the operation of the pixel 100 described in connection with FIGS. 2A and 2B, the compensation voltage Vcomp optionally applied to the source-side terminal 218s is a proper voltage to account for a degradation of the pixel circuit 200, such as the degradation measured during the monitor phase(s) 225, 226 (e.g., an increase in the threshold voltage V_t of the driving transistor 214). Additionally or alternatively, compensation for degradation of the pixel 200 can be accounted for by adjustments to the program voltage Vprog applied to the gate-side terminal 218g.

[0082] Furthermore, similar to the pixel 130 described in connection with FIGS. 3A and 3B, the emission transistor 222 ensures that the driving transistor 214 is isolated from the storage capacitor 218 during the program phase 223. By disconnecting the source-side terminal 218s of the storage capacitor 218 from the driving transistor 214, the emission transistor 222 ensures that the driving transistor is not turned on during programming such

that current flows through a switching transistor. As previously discussed, isolating the driving transistor 214 from the storage capacitor 218 via the emission transistor 222 ensures that the voltage charged on the storage capacitor 218 during the program phase 223 is independent of a resistance of a switching transistor.

[0083] During the emission phase 224 of the pixel 200, the select line 204 is set low while the emission line 210 is high. The data switching transistor 216 and the monitor transistor 212 are turned off and the emission transistor 222 is turned on during the emission phase 224. By turning on the emission transistor 214, the storage capacitor 218 is connected across the gate terminal and the source terminal of the driving transistor 214. The driving transistor 214 draws a driving current from the voltage supply line 206 according to the driving voltage stored on the storage capacitor 218. The OLED 220 is turned on and the voltage at the anode terminal of the OLED 220 adjusts to the operating voltage V_{OLED} of the OLED 220. The storage capacitor 218 maintains the driving voltage by self-adjusting the voltage of the source terminal and/or gate terminal of the driving transistor 218 so as to account for variations on one or the other. For example, if the voltage on the source-side terminal 218s changes during the emission cycle 224 due to, for example, the anode terminal of the OLED 220 settling at the operating voltage V_{OLED} , the storage capacitor 218 adjusts the voltage on the gate terminal of the driving transistor 214 to maintain the driving voltage across the gate and source terminals of the driving transistor 214.

[0084] During the TFT monitor phase 225 of the pixel 200, the select line 204 and the emission line 210 are both set high. The data switching transistor 216, the monitor transistor 212, and the emission transistor 222 are all turned on. The data line 202 is fixed at a first calibration voltage ("Vcal1"), and the monitor line 208 is fixed at a second calibration voltage ("Vcal2"). The first calibration voltage Vcal1 is applied to the gate terminal of the driving transistor 214 through the data switching transistor 216. The second calibration voltage Vcal2 is applied to the source terminal of the driving transistor 214 through the monitor transistor 212 and the emission transistor 222. The first calibration voltage Vcal1 and the second calibration voltage Vcal2 thereby fix the gate-source potential V_{gs} of the driving transistor 214 and the driving transistor 214 draws a current from the voltage supply line 206 according to its gate-source potential V_{gs} . The second calibration voltage Vcal2 is also applied to the anode of the OLED 220 and is advantageously selected to be a voltage sufficient to turn off the OLED 220. Turning off the OLED 220 during the TFT monitor

phase 225 ensures that the current flowing through the driving transistor 214 does not pass through the OLED 220 and instead is conveyed to the monitor line 208 via the emission transistor 222 and the monitor transistor 212. Similar to the description of the monitoring phase 121 in connection with the pixel 100 in FIGS. 2A and 2B, the current measured on the monitor line 208 can be used to extract degradation information for the pixel 200, such as information indicative of the threshold voltage V_t of the driving transistor 214.

[0085] During the OLED monitor phase 226 of the pixel 200, the select line 204 is set high while the emission line 210 is set low. The data switching transistor 216 and the monitor transistor 212 are turned on while the emission transistor 222 is turned off. The data line 202 is fixed at a reference voltage V_{ref} , and the monitor line sources or sinks a fixed current on the monitor line 208. The fixed current on the monitor line 208 is applied to the OLED 220 through the monitor transistor 212, and causes the OLED 220 to settle at its operating voltage V_{OLED} . Thus, by applying a fixed current to the monitor line 208, and measuring the voltage of the monitor line 208, the operating voltage V_{OLED} of the OLED 220 can be extracted.

[0086] It is also note that in FIGS. 5B through 5D, the emission line is generally set to a level within each operating phase for a longer duration than the select line is set to a particular level. By delaying, shortening, or lengthening, the durations of the values held by the select line 204 and/or the emission line 210 during the operating cycles, aspects of the pixel 200 can more accurately settle to stable points prior to subsequent operating cycles. For example, with respect to the program operating cycle 223, setting the emission line 210 low prior to setting the select line 204 high, allows the driving transistor 214 to cease driving current prior to new programming information being applied to the driving transistor via the data switching transistor 216. While this feature of delaying, or providing settling time before and after distinct operating cycles of the pixel 200 is illustrated for the pixel 200, similar modifications can be made to the operating cycles of other circuits disclosed herein, such as the pixels 100, 130, 170, etc.

[0087] While the driving circuit illustrated in FIG. 5A is illustrated with n-type transistors, which can be thin-film transistors and can be formed from amorphous silicon, the driving circuit illustrated in FIG. 5A for the pixel 200 and the operating cycles illustrated in FIGS. 5B through 5D can be extended to a complementary circuit having one or more p-type transistors and having transistors other than thin film transistors.

[0088] FIG. 6A is a circuit diagram for an exemplary pixel circuit configuration for a pixel 240. The driving circuit for the pixel 240 is utilized to program, monitor, and drive the pixel 240. The pixel 240 includes a driving transistor 252 for conveying a driving current through an OLED 256. The OLED 256 is similar to the OLED 110 shown in FIG. 2A and emits light according to the current passing through the OLED 256. The OLED 256 can be replaced by any current-driven light emitting device. The pixel 240 can be incorporated into the display panel 20 and the display system 50 described in connection with FIG. 1, with appropriate line connections to the data driver, address driver, monitoring system, etc.

[0089] The driving circuit for the pixel 240 also includes a storage capacitor 262, a data switching transistor 260, a monitor transistor 258, and an emission transistor 254. The pixel 240 is coupled to a data/monitor line 242, a voltage supply line 246, a first select line 244, a second select line 245, and an emission line 250. The driving transistor 252 draws a current from the voltage supply line 246 according to a gate-source voltage (“ V_{gs} ”) across a gate terminal of the driving transistor 252 and a source terminal of the driving transistor 252, and a threshold voltage (“ V_t ”) of the driving transistor 252. The relationship between the drain-source current and the gate-source voltage of the driving transistor 252 is similar to the operation of the driving transistor 114 described in connection with FIGS. 2A and 2B.

[0090] In the pixel 240, the storage capacitor 262 is coupled across the gate terminal and the source terminal of the driving transistor 252 through the emission transistor 254. The storage capacitor 262 has a first terminal 262g, which is referred to for convenience as a gate-side terminal 262g, and a second terminal 262s, which is referred to for convenience as a source-side terminal 262s. The gate-side terminal 262g of the storage capacitor 262 is electrically coupled to the gate terminal of the driving transistor 252. The source-side terminal 262s of the storage capacitor 262 is electrically coupled to the source terminal of the driving transistor 252 through the emission transistor 254. Thus, when the emission transistor 254 is turned on, the gate-source voltage V_{gs} of the driving transistor 252 is the voltage charged on the storage capacitor 262. The emission transistor 254 is operated according to the emission line 250 (e.g., the emission transistor 254 is turned on when the emission line 250 is set high and vice versa). As will be explained further below, the storage capacitor 262 can thereby maintain a driving voltage across the driving transistor 252 during an emission phase of the pixel 240.

[0091] The drain terminal of the driving transistor 252 is electrically coupled to the voltage supply line 246. The source terminal of the driving transistor 252 is electrically coupled to an anode terminal of the OLED 256 through the emission transistor 254. A cathode terminal of the OLED 256 can be connected to ground or can optionally be connected to a second voltage supply line, such as a supply line Vss. Thus, the OLED 256 is connected in series with the current path of the driving transistor 252. The OLED 256 emits light according to the current passing through the OLED 256 once a voltage drop across the anode and cathode terminals of the OLED 256 achieves an operating voltage (“ V_{OLED} ”) of the OLED 256 similar to the description of the OLED 110 provided in connection with FIGS. 2A and 2B.

[0092] The data switching transistor 260 is operated according to the first select line 244 (e.g., when the first select line 244 is high, the data switching transistor 260 is turned on, and when the first select line 244 is set low, the data switching transistor is turned off). The monitor transistor 258 is similarly operated according to the second select line 245. When turned on, the data switching transistor 260 electrically couples the gate-side terminal 262g of the storage capacitor 262 to the data/monitor line 242. When turned on, the monitor transistor 258 electrically couples the source-side terminal 218s of the storage capacitor 218 to the data/monitor line 242.

[0093] FIG. 6B is a timing diagram for operating the pixel 240 illustrated in FIG. 6A in a program phase and an emission phase. As shown in FIG. 6B, the pixel 240 can be operated in a program phase 227, and an emission phase 228. FIG. 6C is a timing diagram for operating the pixel 240 illustrated in FIG. 6A to monitor aspects of the driving transistor 252. FIG. 6D is a timing diagram for operating the pixel 240 illustrated in FIG. 6A to measure aspects of the OLED 256.

[0094] In an exemplary implementation for operating (“driving”) the pixel 240, the pixel 240 may be operated in the program phase 227 and the emission phase 228 for each frame of a video display. The pixel 240 may also optionally be operated in either or both of the monitor phases monitor degradation of the pixel 200 due to the driving transistor 252 or of the OLED 256, or both.

[0095] During the program phase 227, the first select line 244 is set high, the second select line 245 is set low, and the emission line 250 is set low. The data switching transistor 260 is turned on while the emission transistor 254 and the monitor transistor 258 are turned

off. The data/monitor line 242 is set to a program voltage (“Vprog”). The program voltage Vprog can optionally be adjusted according to compensation information to provide compensation for degradation of the pixel 240. The gate-side terminal 262g of the storage capacitor 262 is set to the program voltage Vprog and the source-side terminal 262s settles at a voltage corresponding to the anode terminal of the OLED 256 while no current is flowing through the OLED 256. The storage capacitor 262 is thereby charged according to the program voltage Vprog. The voltage charged on the storage capacitor 262 during the program phase 227 is referred to as a driving voltage. The driving voltage is a voltage appropriate to be applied across the driving transistor 252 to generate a desired driving current that will cause the OLED 256 to emit a desired amount of light.

[0096] Furthermore, similar to the pixel 160 described in connection with FIGS. 4A and 4B, the emission transistor 254 ensures that the driving transistor 252 is isolated from the storage capacitor 262 during the program phase 227. By disconnecting the source-side terminal 262s of the storage capacitor 262 from the driving transistor 252, the emission transistor 254 ensures that the driving transistor 252 is not turned on during programming such that current flows through a switching transistor. As previously discussed, isolating the driving transistor 252 from the storage capacitor 262 via the emission transistor 254 ensures that the voltage charged on the storage capacitor 262 during the program phase 227 is independent of a resistance of a switching transistor.

[0097] During the emission phase 228 of the pixel 240, the first select line 244 and the second select line 245 are set low while the emission line 250 is high. The data switching transistor 260 and the monitor transistor 258 are turned off and the emission transistor 254 is turned on during the emission phase 228. By turning on the emission transistor 254, the storage capacitor 262 is connected across the gate terminal and the source terminal of the driving transistor 252. The driving transistor 252 draws a driving current from the voltage supply line 246 according to the driving voltage stored on the storage capacitor 262. The OLED 256 is turned on and the voltage at the anode terminal of the OLED 256 adjusts to the operating voltage V_{OLED} of the OLED 256. The storage capacitor 262 maintains the driving voltage by self-adjusting the voltage of the source terminal and/or gate terminal of the driving transistor 252 so as to account for variations on one or the other. For example, if the voltage on the source-side terminal 262s changes during the emission cycle 228 due to, for example, the anode terminal of the OLED 256 settling at the operating voltage V_{OLED} , the storage

capacitor 262 adjusts the voltage on the gate terminal of the driving transistor 252 to maintain the driving voltage across the gate and source terminals of the driving transistor 252.

[0098] A TFT monitor operation includes a charge phase 229 and a read phase 230. During the charge phase 229, the first select line 244 is set high while the second select line 245 and the emission line 250 are set low. Similar to the program phase 227, the gate-side terminal 262g of the storage capacitor 262 is charged with a first calibration voltage (“Vcal1”) that is applied to the data/monitor line 242. Next, during the read phase 230, the first select line 244 is set low and the second select line 245 and the emission line 250 are set high. The data/monitor line 242 is set to a second calibration voltage (“Vcal2”). The second calibration voltage Vcal2 advantageously reverse biases the OLED 256 such that current flowing through the driving transistor 252 flows to the data/monitor line 242. The data/monitor line 242 is maintained at the second calibration voltage Vcal2 while the current is measured. Comparing the measured current with the first calibration voltage Vcal1 and the second calibration voltage Vcal2 allows for the extraction of degradation information related to the driving transistor 252, similar to the previous descriptions.

[0099] An OLED monitor operation also includes a charge phase 231 and a read phase 232. During the charge phase 231, the first select line 244 is set high while the second select line 245 and the emission line 250 are set low. The data switching transistor 260 is turned on and applies a calibration voltage (“Vcal”) to the gate-side terminal 262g of the storage capacitor 262. During the read phase 232, the current on the data/monitor line 242 is fixed while the voltage is measured to extract the operating voltage (“V_{OLED}”) of the OLED 256.

[00100] The pixel 240 advantageously combines the data line and monitor line in a single line, which allows the pixel 240 to be packaged in a smaller area compared to pixels lacking such a combination, and thereby increase pixel density and display screen resolution.

[00101] While the driving circuit illustrated in FIG. 6A is illustrated with n-type transistors, which can be thin-film transistors and can be formed from amorphous silicon, the driving circuit illustrated in FIG. 6A for the pixel 240 and the operating cycles illustrated in FIGS. 6B through 6D can be extended to a complementary circuit having one or more p-type transistors and having transistors other than thin film transistors.

[00102] FIG. 7A is a circuit diagram for an exemplary pixel driving circuit for a pixel 270. The pixel 270 is structurally similar to the pixel 100 in FIG. 2A, except that the pixel

270 incorporates an additional emission transistor 286 between the driving transistor 284 and the OLED 288, and except that the configuration of the data line 272 and the monitor line 278 differs from the pixel 100. The emission transistor 286 is also positioned between the storage capacitor 292 and the OLED 288, such that during a program phase of the pixel 270, the storage capacitor 292 can be electrically disconnected from the OLED 288. Disconnecting the storage capacitor 292 from the OLED 288 during programming prevents the programming of the storage capacitor 292 from being influenced or perturbed due to the capacitance of the OLED 288. In addition to the differences introduced by the emission transistor 286 and the configuration of the data and monitor lines, the pixel 270 can also operate differently than the pixel 100, as will be described further below.

[00103] FIG. 7B is a timing diagram for operating the pixel 270 illustrated in FIG. 7A in a program phase and an emission phase. As shown in FIG. 7B, the pixel 270 can be operated in a program phase 233, and an emission phase 234. FIG. 7C is a timing diagram for operating the pixel 270 illustrated in FIG. 7A in a TFT monitor phase 235 to measure aspects of the driving transistor 284. FIG. 7D is a timing diagram for operating the pixel 270 illustrated in FIG. 7A in an OLED monitor phase 236 to measure aspects of the OLED 288.

[00104] In an exemplary implementation for operating (“driving”) the pixel 270, the pixel 270 may be operated with a program phase 233 and an emission phase 234 for each frame of a video display. The pixel 270 may also optionally be operated in either or both of the monitor phases 235, 236 to monitor degradation of the pixel 270 due to the driving transistor 284 or of the OLED 288, or both. The pixel 270 may be operated in the monitor phase(s) 235, 236 intermittently, periodically, or according to a sorting and prioritization algorithm to dynamically determine and identify pixels in a display that require updated degradation information for providing compensation therefore. Therefore, a driving sequence corresponding to a single frame being displayed via the pixel 270 can include the program phase 233 and the emission phase 234, and can optionally either or both of the monitor phases 235, 236.

[00105] During the program phase 233, the select line 274 is set high and the emission line 280 is set low. The data switching transistor 290 and the monitor transistor 282 are turned on while the emission transistor 286 is turned off. The data line 272 is set to a program voltage (“V_{prog}”) and the monitor line 278 is fixed at a reference voltage (“V_{ref}”). The monitor line 278 can optionally be set to a compensation voltage (“V_{comp}”) rather than

the reference voltage V_{ref} . The gate-side terminal 292g of the storage capacitor 292 is set to the program voltage V_{prog} and the source-side terminal 292s is set to the reference voltage V_{ref} (or the compensation voltage V_{comp}). The storage capacitor 292 is thereby charged according to the difference between the program voltage V_{prog} and the reference voltage V_{ref} (or the compensation voltage V_{comp}). The voltage charged on the storage capacitor 292 during the program phase 233 is referred to as a driving voltage. The driving voltage is a voltage appropriate to be applied across the driving transistor to generate a desired driving current that will cause the OLED 288 to emit a desired amount of light. Similar to the operation of the pixel 100 described in connection with FIGS. 2A and 2B, the compensation voltage V_{comp} optionally applied to the source-side terminal 292s is a proper voltage to account for a degradation of the pixel circuit 270, such as the degradation measured during the monitor phase(s) 235, 236 (e.g., an increase in the threshold voltage V_t of the driving transistor 284). Additionally or alternatively, compensation for degradation of the pixel 270 can be accounted for by adjustments to the program voltage V_{prog} applied to the gate-side terminal 292g.

[00106] During the emission phase 234 of the pixel 270, the select line 274 is set low while the emission line 280 is high. The data switching transistor 290 and the monitor transistor 282 are turned off and the emission transistor 286 is turned on during the emission phase 234. By turning on the emission transistor 286, the storage capacitor 292 is connected across the gate terminal and the source terminal of the driving transistor 284. The driving transistor 284 draws a driving current from the voltage supply line 276 according to the driving voltage stored on the storage capacitor 292. The OLED 288 is turned on and the voltage at the anode terminal of the OLED 288 adjusts to the operating voltage V_{OLED} of the OLED 288. The storage capacitor 292 maintains the driving voltage by self-adjusting the voltage of the source terminal and/or gate terminal of the driving transistor 284 so as to account for variations on one or the other. For example, if the voltage on the source-side terminal 292s changes during the emission cycle 234 due to, for example, the anode terminal of the OLED 288 settling at the operating voltage V_{OLED} , the storage capacitor 292 adjusts the voltage on the gate terminal of the driving transistor 284 to maintain the driving voltage across the gate and source terminals of the driving transistor 284.

[00107] During the TFT monitor phase 235 of the pixel 270, the select line 274 is set high while the emission line 280 is set low. The data switching transistor 290 and the

monitor transistor 282 are turned on while the emission transistor 286 is turned off. The data line 272 is fixed at a first calibration voltage (“Vcal1”), and the monitor line 278 is fixed at a second calibration voltage (“Vcal2”). The first calibration voltage Vcal1 is applied to the gate terminal of the driving transistor 284 through the data switching transistor 290. The second calibration voltage Vcal2 is applied to the source terminal of the driving transistor 284 through the monitor transistor 282. The first calibration voltage Vcal1 and the second calibration voltage Vcal2 thereby fix the gate-source potential V_{gs} of the driving transistor 284 and the driving transistor 284 draws a current from the voltage supply line 276 according to its gate-source potential V_{gs} . The emission transistor 286 is turned off, which removes the OLED 288 from the current path of the driving transistor 284 during the TFT monitor phase 235. The current from the driving transistor 284 is thus conveyed to the monitor line 278 via the monitor transistor 282. Similar to the description of the monitoring phase 121 in connection with the pixel 100 in FIGS. 2A and 2B, the current measured on the monitor line 278 can be used to extract degradation information for the pixel 270, such as information indicative of the threshold voltage V_t of the driving transistor 284.

[00108] During the OLED monitor phase 236 of the pixel 270, the select line 274 and the emission line 280 are set high. The data switching transistor 290, the monitor transistor 282, and the emission transistor 286 are all turned on. The data line 272 is fixed at a reference voltage V_{ref} , and the monitor line sources or sinks a fixed current on the monitor line 278. The fixed current on the monitor line 278 is applied to the OLED 288 through the monitor transistor 282, and causes the OLED 288 to settle at its operating voltage V_{OLED} . Thus, by applying a fixed current to the monitor line 278, and measuring the voltage of the monitor line 278, the operating voltage V_{OLED} of the OLED 288 can be extracted.

[00109] While the driving circuit illustrated in FIG. 7A is illustrated with n-type transistors, which can be thin-film transistors and can be formed from amorphous silicon, the driving circuit illustrated in FIG. 7A for the pixel 270 and the operating cycles illustrated in FIGS. 7B through 7D can be extended to a complementary circuit having one or more p-type transistors and having transistors other than thin film transistors.

[00110] Circuits disclosed herein generally refer to circuit components being connected or coupled to one another. In many instances, the connections referred to are made via direct connections, i.e., with no circuit elements between the connection points other than conductive lines. Although not always explicitly mentioned, such connections can be made

by conductive channels defined on substrates of a display panel such as by conductive transparent oxides deposited between the various connection points. Indium tin oxide is one such conductive transparent oxide. In some instances, the components that are coupled and/or connected may be coupled via capacitive coupling between the points of connection, such that the points of connection are connected in series through a capacitive element. While not directly connected, such capacitively coupled connections still allow the points of connection to influence one another via changes in voltage which are reflected at the other point of connection via the capacitive coupling effects and without a DC bias.

[00111] Furthermore, in some instances, the various connections and couplings described herein can be achieved through non-direct connections, with another circuit element between the two points of connection. Generally, the one or more circuit element disposed between the points of connection can be a diode, a resistor, a transistor, a switch, etc. Where connections are non-direct, the voltage and/or current between the two points of connection are sufficiently related, via the connecting circuit elements, to be related such that the two points of connection can influence each another (via voltage changes, current changes, etc.) while still achieving substantially the same functions as described herein. In some examples, voltages and/or current levels may be adjusted to account for additional circuit elements providing non-direct connections, as can be appreciated by individuals skilled in the art of circuit design.

[00112] Any of the circuits disclosed herein can be fabricated according to many different fabrication technologies, including for example, poly-silicon, amorphous silicon, organic semiconductor, metal oxide, and conventional CMOS. Any of the circuits disclosed herein can be modified by their complementary circuit architecture counterpart (*e.g.*, n-type transistors can be converted to p-type transistors and vice versa).

[00113] Two or more computing systems or devices may be substituted for any one of the controllers described herein. Accordingly, principles and advantages of distributed processing, such as redundancy, replication, and the like, also can be implemented, as desired, to increase the robustness and performance of controllers described herein.

[00114] The operation of the example determination methods and processes described herein may be performed by machine readable instructions. In these examples, the machine readable instructions comprise an algorithm for execution by: (a) a processor, (b) a controller, and/or (c) one or more other suitable processing device(s). The algorithm may be embodied

in software stored on tangible media such as, for example, a flash memory, a CD-ROM, a floppy disk, a hard drive, a digital video (versatile) disk (DVD), or other memory devices, but persons of ordinary skill in the art will readily appreciate that the entire algorithm and/or parts thereof could alternatively be executed by a device other than a processor and/or embodied in firmware or dedicated hardware in a well known manner (e.g., it may be implemented by an application specific integrated circuit (ASIC), a programmable logic device (PLD), a field programmable logic device (FPLD), a field programmable gate array (FPGA), discrete logic, etc.). For example, any or all of the components of the baseline data determination methods could be implemented by software, hardware, and/or firmware. Also, some or all of the machine readable instructions represented may be implemented manually.

[00115] While particular embodiments and applications of the present invention have been illustrated and described, it is to be understood that the invention is not limited to the precise construction and compositions disclosed herein and that various modifications, changes, and variations can be apparent from the foregoing descriptions without departing from the spirit and scope of the invention as defined in the appended claims.

WHAT IS CLAIMED IS:

1. A system for compensating a pixel in a display array, the system comprising:
 - a pixel circuit for being programmed according to programming information, during a programming cycle, and driven to emit light according to the programming information, during an emission cycle, the pixel circuit including:
 - a light emitting device for emitting light during the emission cycle,
 - a driving transistor for conveying current through the light emitting device during the emission cycle,
 - a storage capacitor for being charged with a voltage based at least in part on the programming information, during the programming cycle, and
 - an emission control transistor arranged to selectively connect, during the emission cycle, at least two of the light emitting device, the driving transistor, and the storage capacitor, such that current is conveyed through the light emitting device via the driving transistor according to the voltage on the storage capacitor; and
 - a driver for programming the pixel circuit via a data line by charging the storage capacitor according to the programming information;
 - a monitor for extracting a voltage or a current indicative of aging degradation of the pixel circuit; and
 - a controller for operating the monitor and the driver and configured to:
 - receive an indication of the amount of degradation from the monitor;
 - receive a data input indicative of an amount of luminance to be emitted from the light emitting device;
 - determine an amount of compensation to provide to the pixel circuit based on the amount of degradation; and
 - provide the programming information to the driver to program the pixel circuit, wherein the programming information is based at least in part on the received data input and the determined amount of compensation.
2. The system according to claim 1, wherein the pixel circuit further includes:

a data switch transistor, operated according to a select line, for coupling the source terminal of the driving transistor to the data line, the data line being coupled to the monitor for measuring a current through the driving transistor during a monitoring cycle.

3. The system according to claim 2, wherein the data switch transistor is coupled to the light emitting device, and wherein the data line is fixed at a calibration voltage during the monitoring cycle, the calibration voltage being sufficient to turn off the light emitting device such that, during the monitoring cycle, current through the driving transistor is not conveyed through the light emitting device.

4. The system according to claim 2, wherein the monitor includes a voltage monitor for monitoring an operating voltage of the light emitting device via the data switch transistor.

5. The system according to claim 1, wherein the emission control transistor is connected between the gate terminal of the driving transistor and the storage capacitor such that the gate terminal of the driving transistor is isolated from the storage capacitor, during the programming cycle while the emission control transistor is turned off.

6. The system according to claim 5, further comprising a reference switch transistor connected between the storage capacitor and a reference line, such that the storage capacitor is charged, during the programming cycle, according to a difference between a reference voltage applied to the reference line and a programming voltage applied on the data line.

7. The system according to claim 6, wherein the reference line provides a compensation voltage, during the programming phase, the compensation voltage being based on the amount of compensation determined by the controller.

8. The system according to claim 1, further comprising:

a data switch transistor operated according to a select line, for coupling a source terminal of the driving transistor to the data line, during programming and monitoring cycles;

a first reference switch transistor operated according to the select line, for coupling the gate terminal of the driving transistor to a first reference line, during the programming cycle, such that the driving transistor is turned off during the programming cycle; and

a second reference switch transistor operated according to the select line, for coupling a second reference line to a terminal of the storage capacitor other than one connected to the data switch transistor, such that the storage capacitor is charged, during the programming cycle while the data switch transistor, first reference switch transistor, and second reference

transistor are turned on, according to a difference between a programming voltage applied on the data line and a reference voltage or compensation voltage on the second reference line.

9. The system according to claim 8, wherein the data line is coupled to the monitor for measuring a current through the driving transistor during a monitoring cycle of the pixel circuit.

10. The system according to claim 8, further comprising a plurality of similar pixel circuits arranged in rows and columns to form a display panel, and wherein the controller is further configured to receive an indication of aging degradation for each of the plurality of pixel circuits, determine an amount of degradation for each of the plurality of pixel circuits, and program each of the plurality of pixel circuits according to the respective determined amounts of compensation.

11. The system according to claim 1, wherein the emission control transistor couples the storage capacitor across a gate terminal and a source terminal of the driving transistor during the emission cycle, the pixel circuit further comprising:

- a data switch transistor, operated according to a select line, for coupling the data line to a terminal of the storage capacitor coupled to the gate terminal of the driving transistor; and

- a monitoring switch transistor, operated according to the select line, for coupling a monitor line to a terminal of the storage capacitor coupled to the emission transistor, the monitor line being coupled to the monitor for measuring the current through the drive transistor during the monitoring cycle.

12. The system according to claim 11, wherein the monitor line is fixed at a calibration voltage during the monitoring cycle, the calibration voltage being sufficient to turn off the light emitting device such that, during the monitoring cycle, current through the driving transistor is not conveyed through the light emitting device

13. The system according to claim 11, wherein the emission control transistor is coupled between the storage capacitor and the light emitting device, thereby isolating the storage capacitor from the light emitting device, during the programming phase, so as to prevent the voltage applied to the storage capacitor from being influenced by an internal capacitance of the light emitting device.

14. The system according to claim 11, wherein the emission control transistor is coupled between the source terminal of the driving transistor and the light emitting device, thereby

preventing the driving transistor from conveying current to the light emitting device while the emission control transistor is switched off.

15. The system according to claim 14, wherein a terminal of the emission transistor coupled to the driving transistor is also coupled to the storage capacitor and the monitoring switch transistor.

16. The system according to claim 1, wherein the pixel circuit further includes:
a data switch transistor, operated according to a first select line, for coupling the data line to a terminal of the storage capacitor coupled to the gate terminal of the driving transistor; and
a monitoring switch transistor, operated according to a second select line, for coupling the data line to a terminal of the storage capacitor coupled to the emission transistor, the monitor line being coupled to the monitor for measuring the current through the drive transistor during the monitoring phase.

17. The system according to claim 1, wherein the light emitting device is an organic light emitting diode.

18. A pixel circuit for driving a light emitting device, the pixel circuit comprising:
a driving transistor for driving current through a light emitting device according to a driving voltage applied across the driving transistor;
a storage capacitor for being charged, during a programming cycle, with the driving voltage;
an emission control transistor for connecting at least two of the driving transistor, the light emitting device, and the storage capacitor, such that current is conveyed through the driving transistor, during the emission cycle, according to voltage charged on the storage capacitor; and
at least one switch transistor for connecting a current path through the driving transistor to a monitor for receiving indications of aging information based on the current through the driving transistor, during a monitoring cycle.

19. The pixel circuit according to claim 18, wherein the emission control transistor is connected in series with the light emitting device so as to prevent the driving transistor from conveying a current through the at least one switch transistor while the pixel circuit is being programmed during the programming cycle.

20. The pixel circuit according to claim 19, wherein the pixel circuit is programmed independent of a resistance of the at least one switch transistor.
21. The pixel circuit according to claim 18, wherein the storage capacitor is connected across a gate terminal and a source terminal of the driving transistor during the emission cycle via the emission control transistor, and wherein the storage capacitor is disconnected from at least one of the gate terminal or the source terminal of the driving transistor during a programming cycle.
22. The pixel circuit according to claim 18, further including:
 - a data switch transistor, operated according to a select line, for coupling, during the programming cycle, the data line to a terminal of the storage capacitor coupled to the gate terminal of the driving transistor; and
 - wherein the at least one switch transistor is a monitoring switch transistor, operated according to the select line or another select line, for conveying a current or voltage indicative of an amount of degradation of the pixel circuit to the monitor, during the monitoring cycle, the monitoring switch transistor being coupled to both the emission control transistor and the storage capacitor.
23. The pixel circuit according to claim 18, wherein the emission transistor and the storage capacitor are coupled in series between the gate terminal and source terminal of the driving transistor.
24. The pixel circuit according to claim 18, wherein the light emitting device includes an organic light emitting diode.
25. A pixel circuit for driving a light emitting device, the pixel circuit comprising:
 - a driving transistor for driving current through a light emitting device according to a driving voltage applied across the driving transistor;
 - a storage capacitor for being charged, during a programming cycle, with the driving voltage;
 - one or more switch transistors for connecting the storage capacitor to one or more data lines or reference lines providing voltages sufficient to charge the storage capacitor with the driving voltage, during the programming cycle; and
 - an emission control transistor, operated according to an emission line, for disconnecting the storage capacitor from the light emitting device during the

programming cycle, such that the storage capacitor is charged independent of the capacitance of the light emitting device.

26. The pixel circuit according to claim 25, wherein the emission control transistor is connected in series between the driving transistor and the light emitting device such that the light emitting device receives current from the driving transistor while the emission control transistor is turned on.

27. A display system comprising:

a pixel circuit for being programmed according to programming information, during a programming cycle, and driven to emit light according to the programming information, during an emission cycle, the pixel circuit including:

a light emitting device for emitting light during the emission cycle,

a driving transistor for conveying current through the light emitting device during the emission cycle, the current being conveyed according to a voltage across a gate and a source terminal of the driving transistor,

a storage capacitor for being charged with a voltage based at least in part on the programming information, during the programming cycle, the storage capacitor connected across the gate and source terminals of the driving transistor, and

a first switch transistor connecting the source terminal of the driving transistor to a data line;

a driver for programming the pixel circuit via the data line by applying a voltage to a terminal of the storage capacitor that is connected to the source terminal of the driving transistor;

a monitor for extracting a voltage or a current indicative of aging degradation of the pixel circuit; and

a controller for operating the monitor and the driver and configured to:

receive an indication of the amount of degradation from the monitor;

receive a data input indicative of an amount of luminance to be emitted from the light emitting device;

determine an amount of compensation to provide to the pixel circuit based on the amount of degradation; and

provide the programming information to the driver to program the pixel circuit, wherein the programming information is based at least in part on the received data input and the determined amount of compensation.

28. The display system according to claim 27, wherein the pixel circuit further includes a second switch transistor connecting the gate terminal of the driving transistor to a reference line.
29. The display system according to claim 28, wherein the first and second switch transistors are operated according to a common select line.
30. The display system according to claim 29, wherein the controller is further configured to apply a reference voltage on the reference line, during the programming cycle, such that the storage capacitor is charged according to the difference between the reference voltage and the voltage on the data line.
31. The display system according to claim 29, wherein the controller is further configured to apply a compensation voltage, on the reference line, during the programming cycle, wherein the compensation voltage is based on the determined amount of compensation.
32. The display system according to claim 27, further comprising a plurality of similar pixel circuits arranged in an array of rows and columns to form a display panel, and wherein the controller is configured to extract indications of aging degradation for each pixel circuit in the display panel, determine an amount of compensation for each pixel circuit in the display panel, and program each pixel circuit in the display panel according to the respective determined amounts of compensation.
33. The display system according to claim 27, wherein the light emitting device includes a light emitting diode.

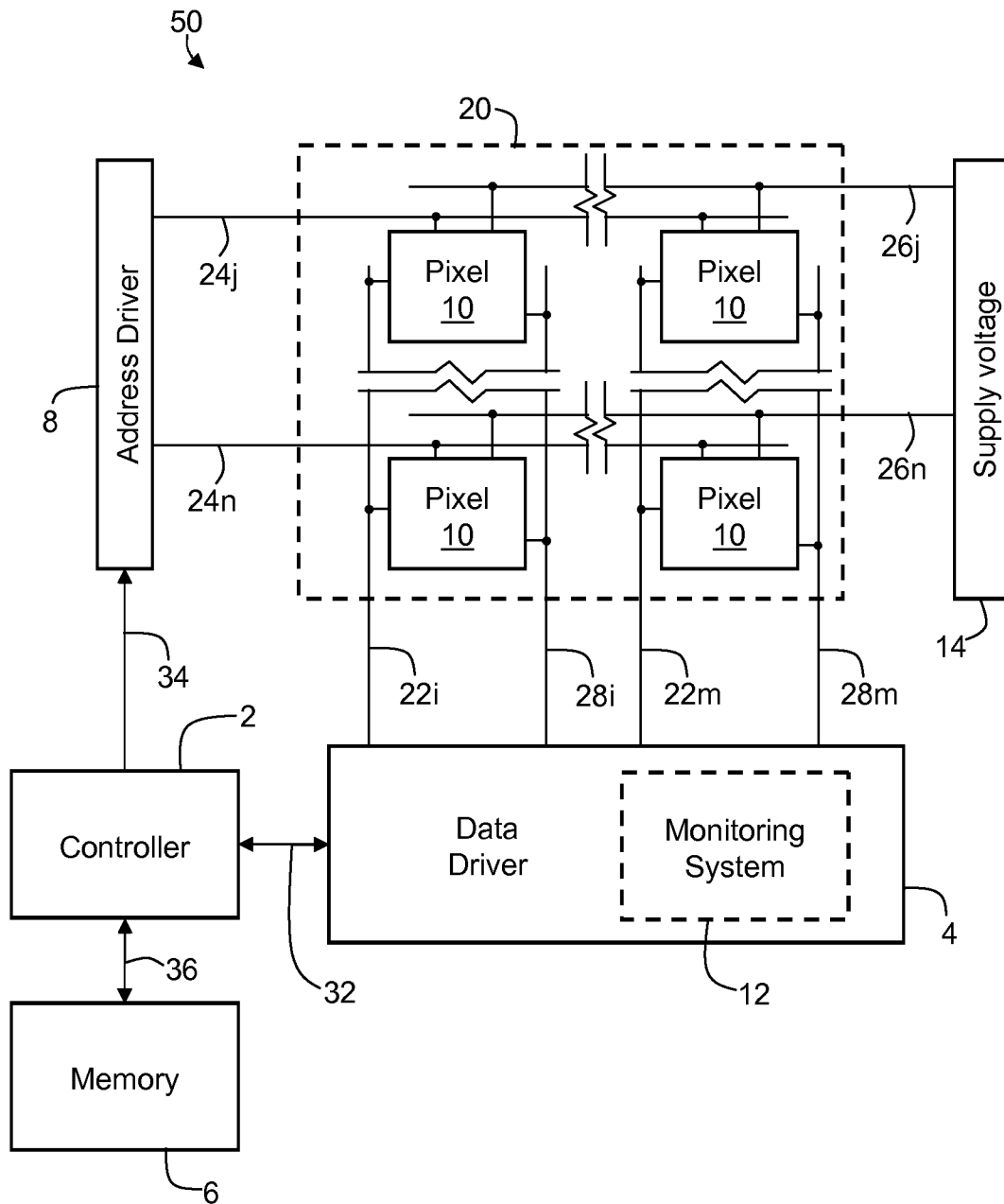

FIG. 1

2/10

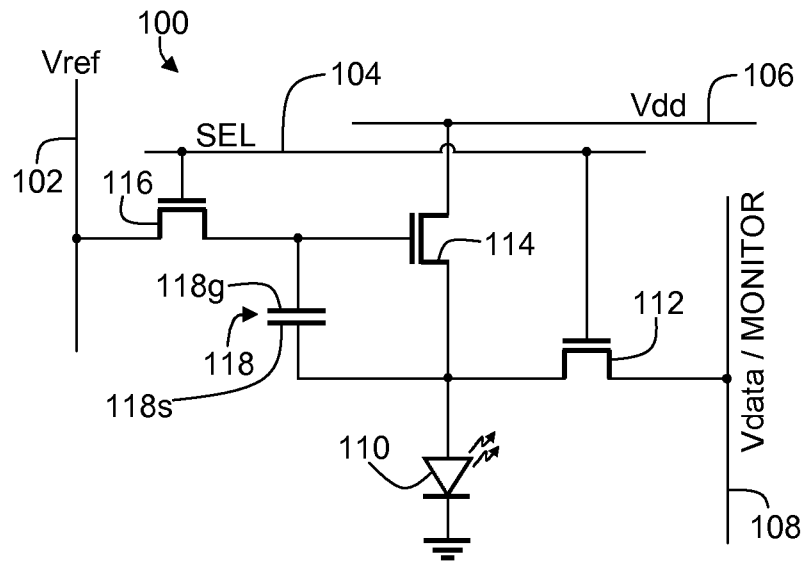

FIG. 2A

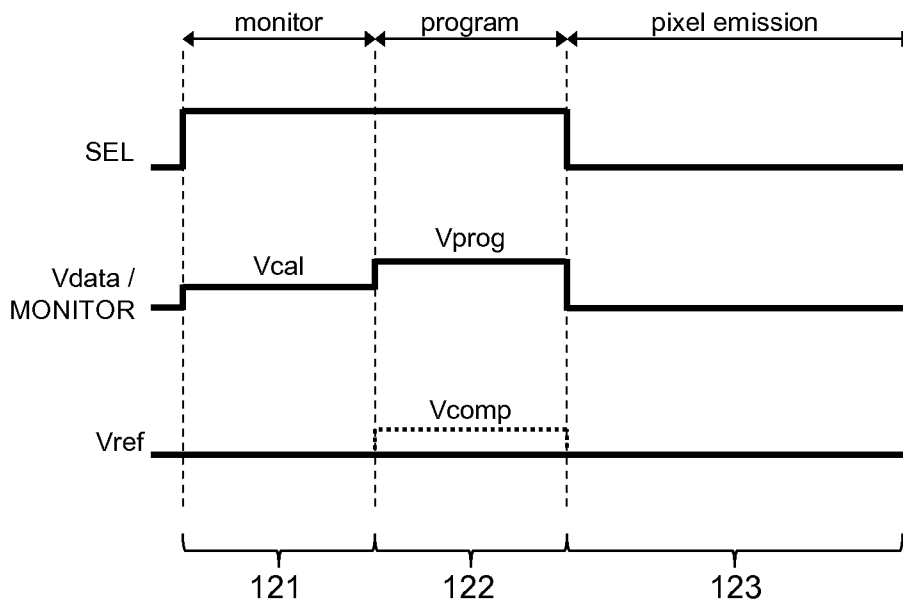

FIG. 2B

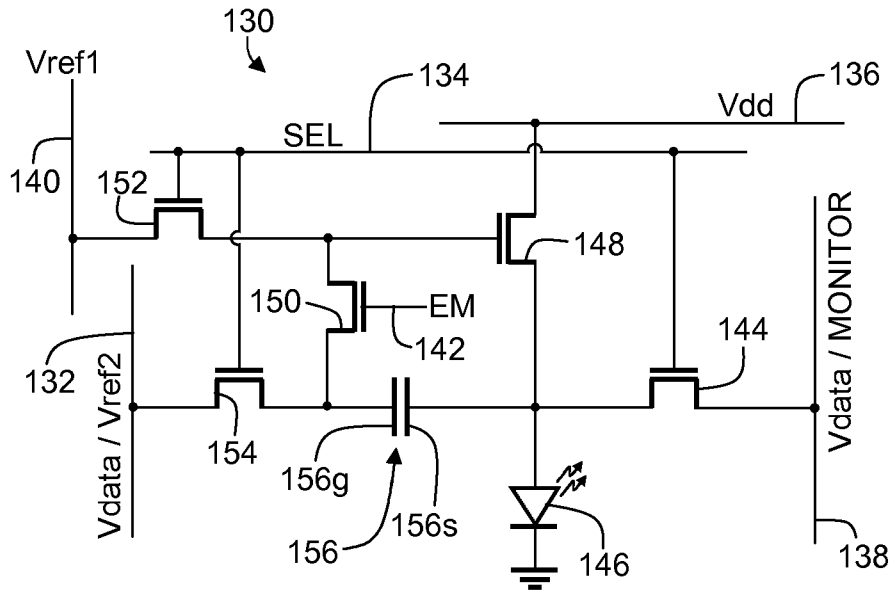

FIG. 3A

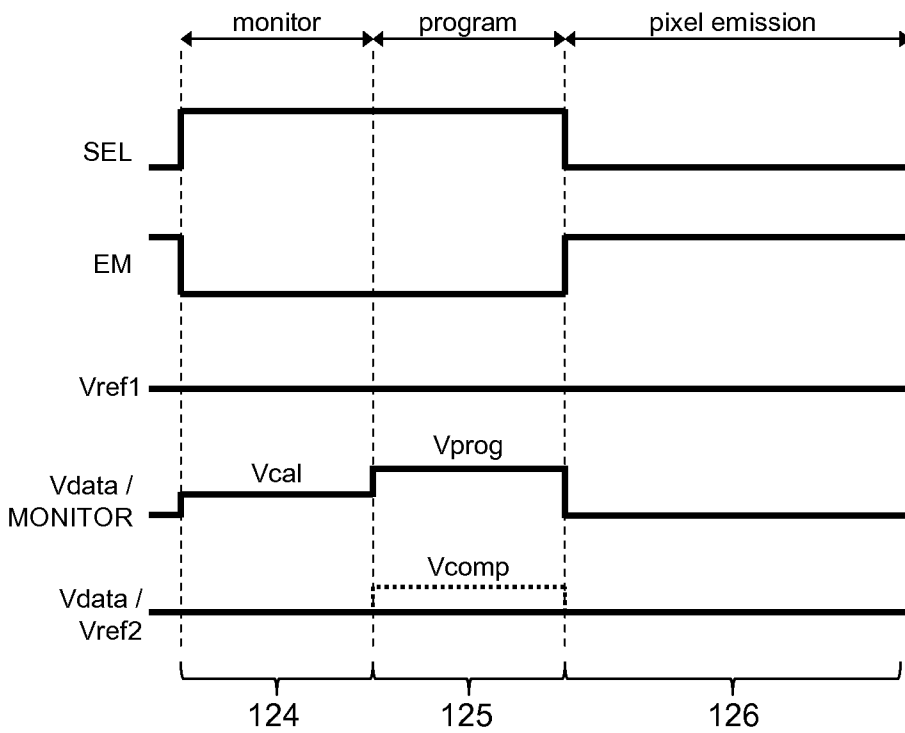

FIG. 3B

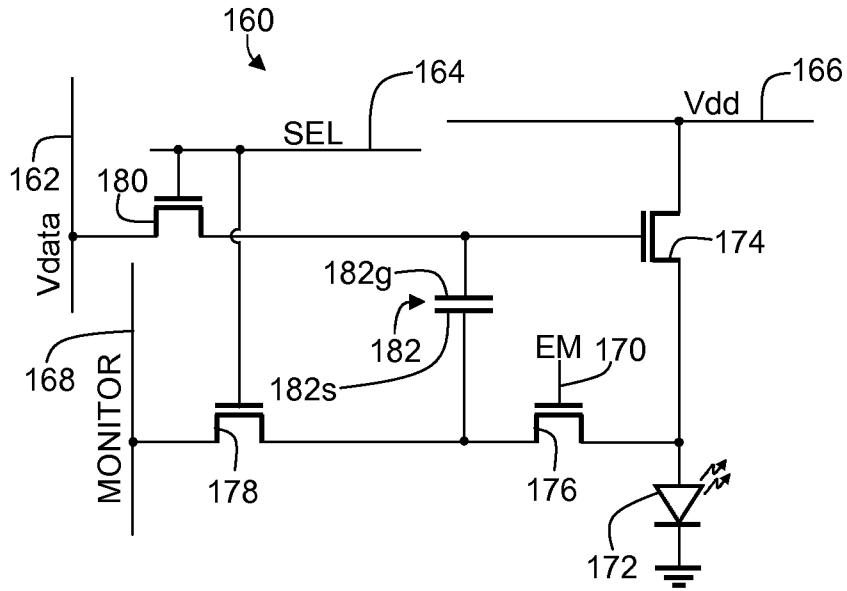

FIG. 4A

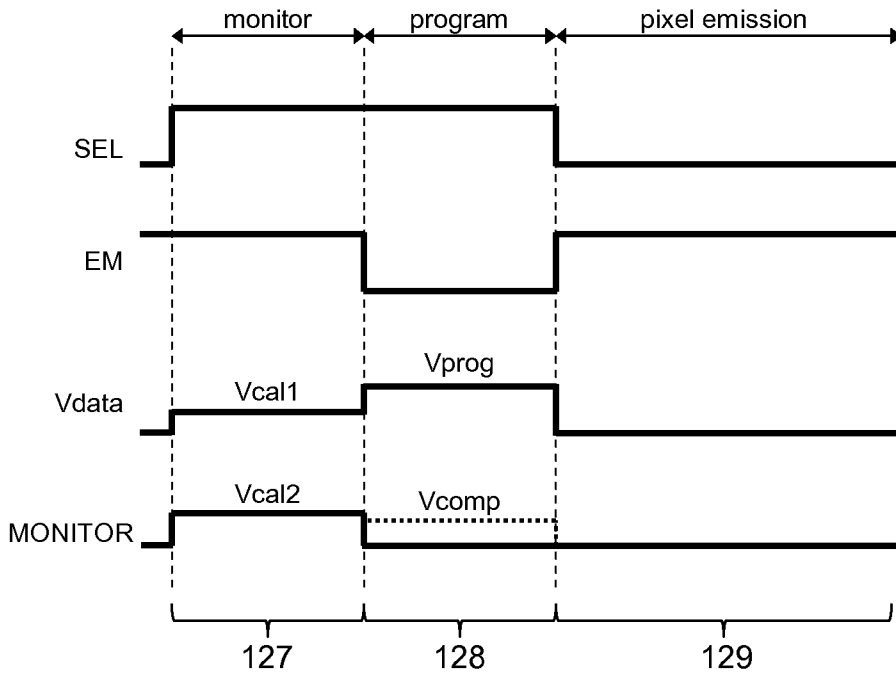

FIG. 4B

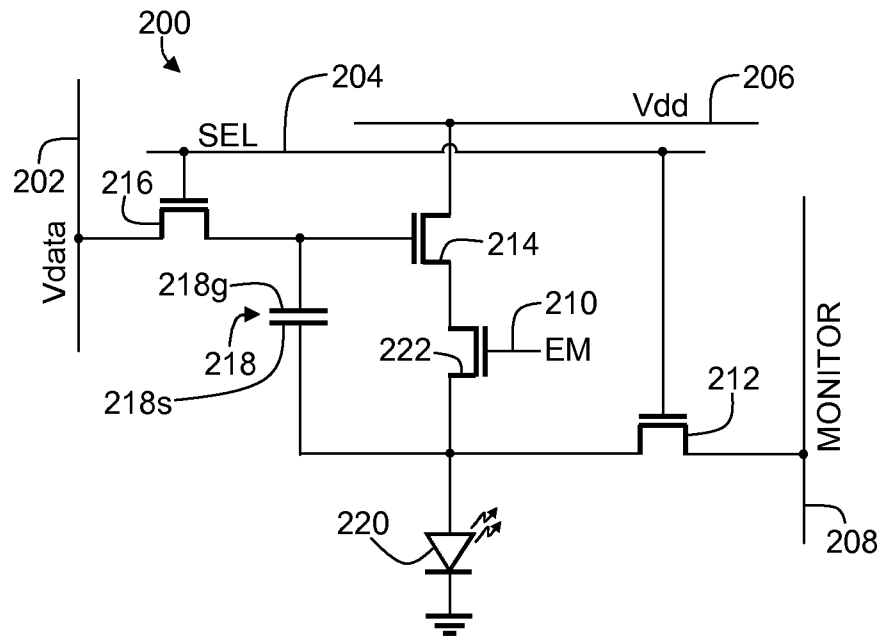

FIG. 5A

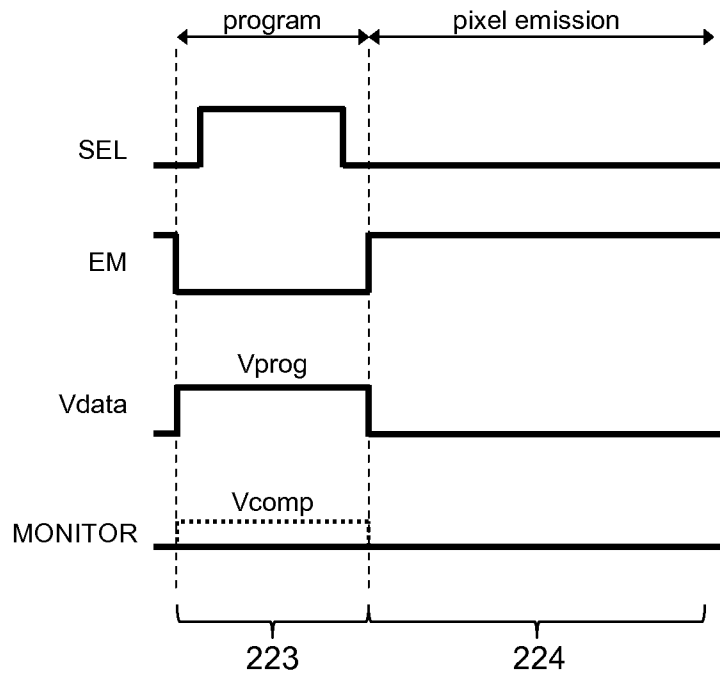

FIG. 5B

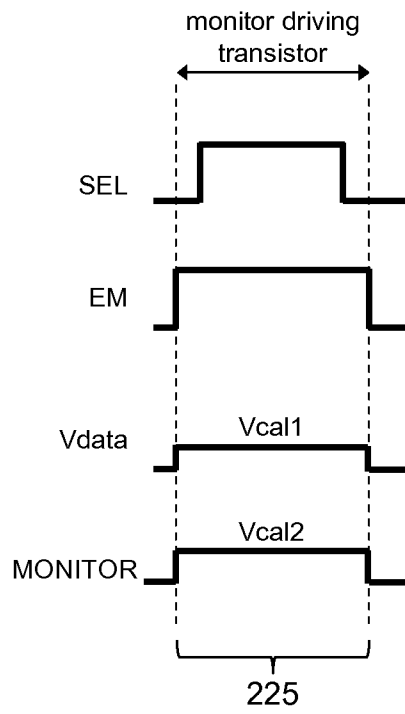

FIG. 5C

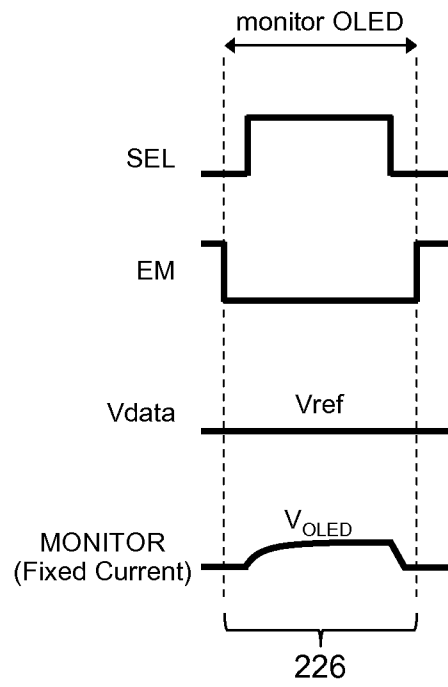

FIG. 5D

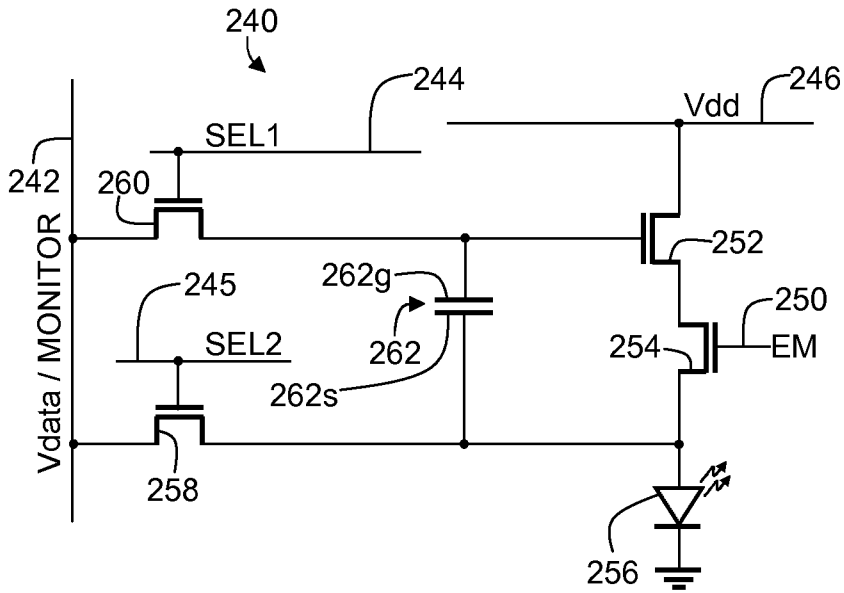

FIG. 6A

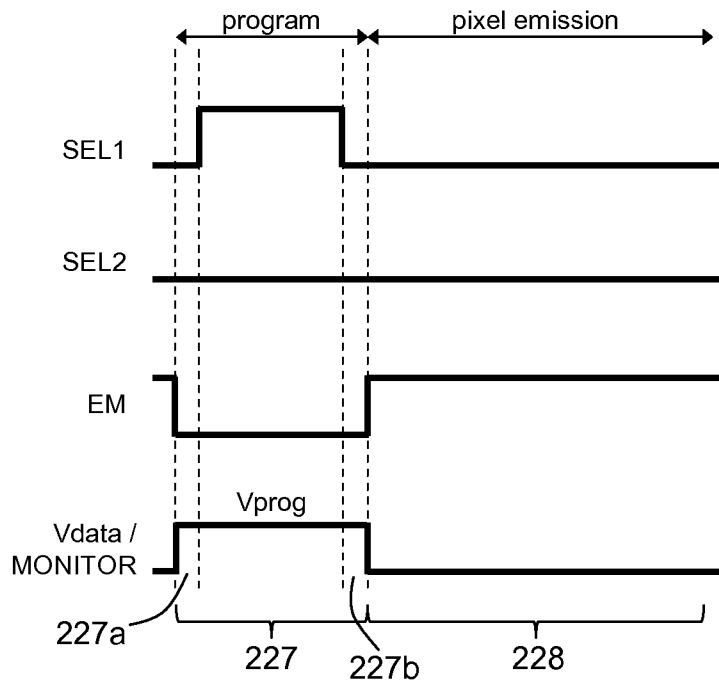

FIG. 6B

8/10

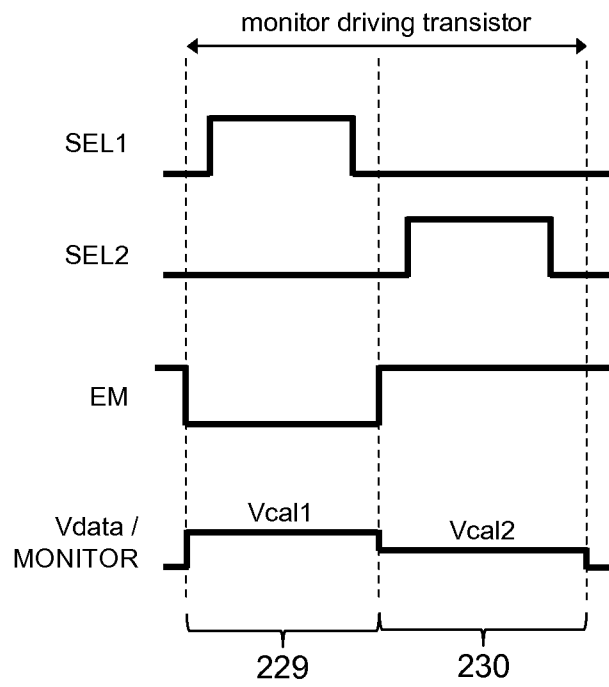

FIG. 6C

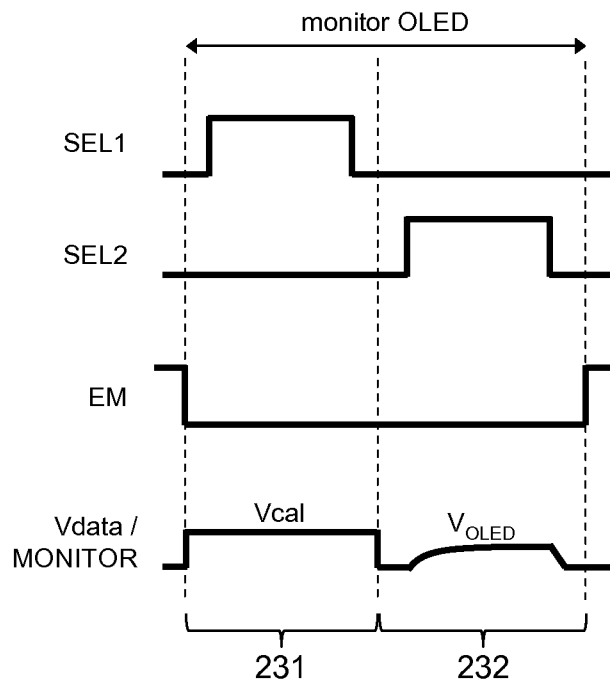

FIG. 6D

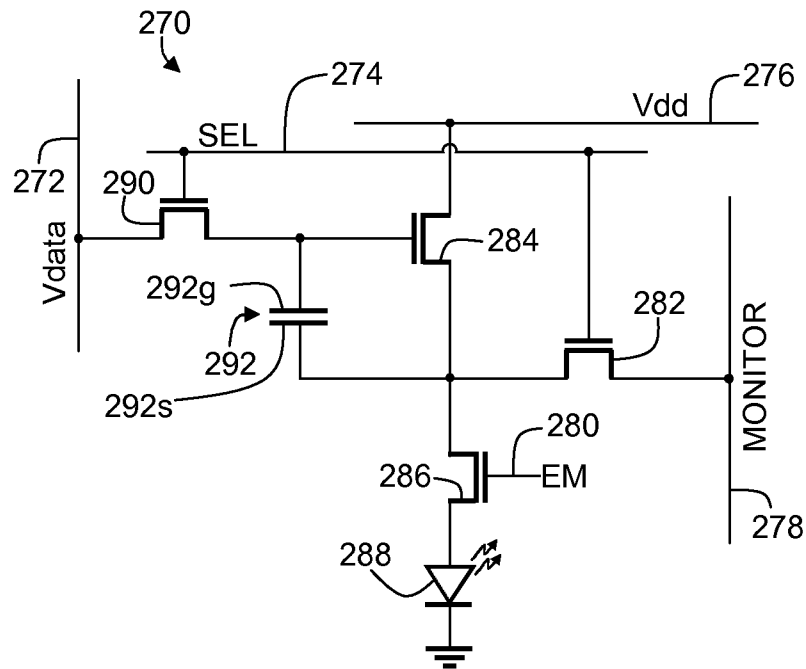

FIG. 7A

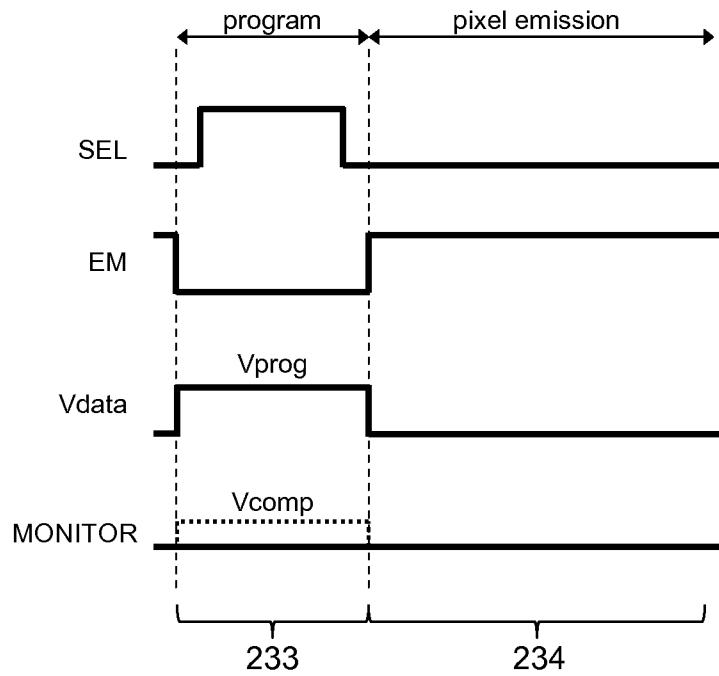

FIG. 7B

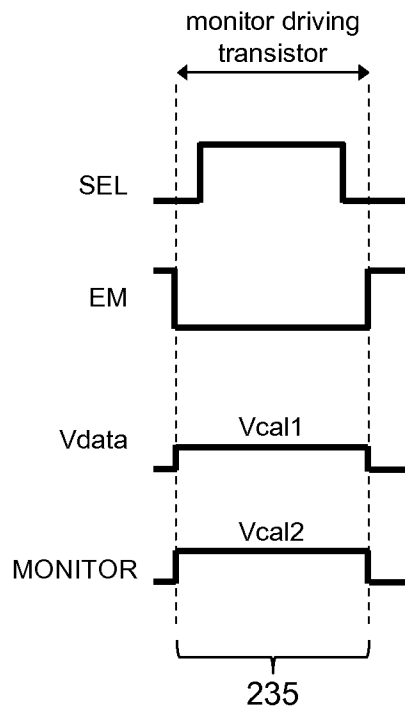

FIG. 7C

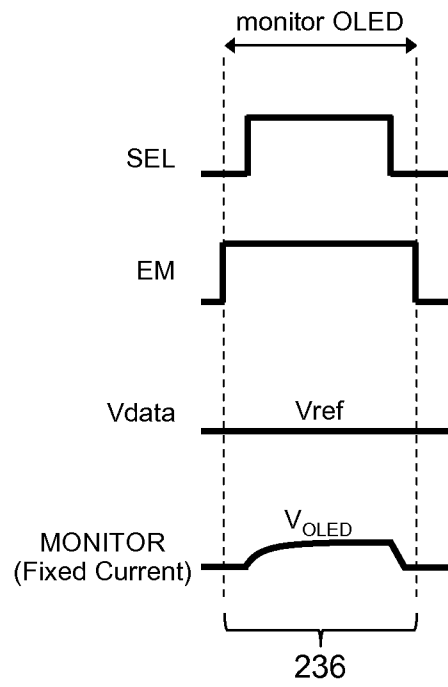

FIG. 7D