

June 21, 1949.

P. O. CARTUN
INTERNAL EXHAUST SEAL FOR ELECTRIC
LAMPS AND SIMILAR DEVICES
Filed Nov. 9, 1946

2,473,860

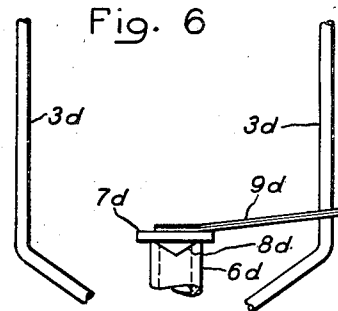
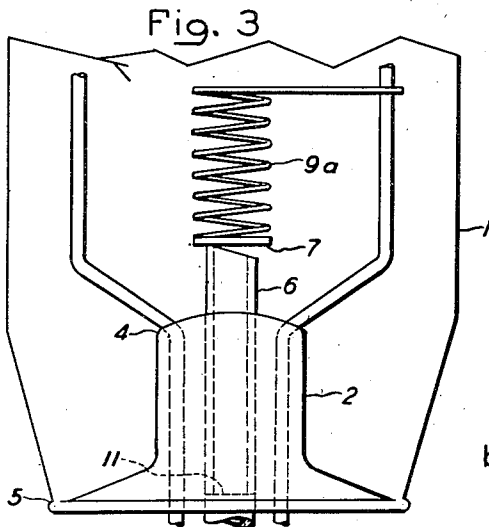
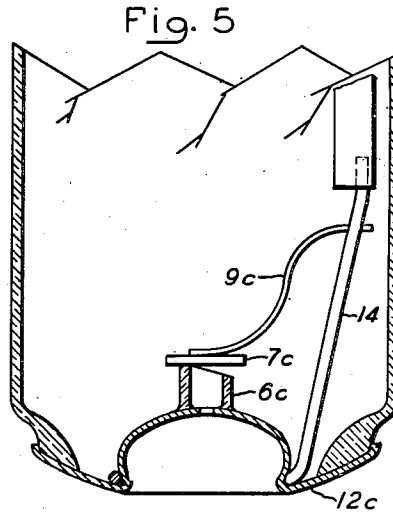
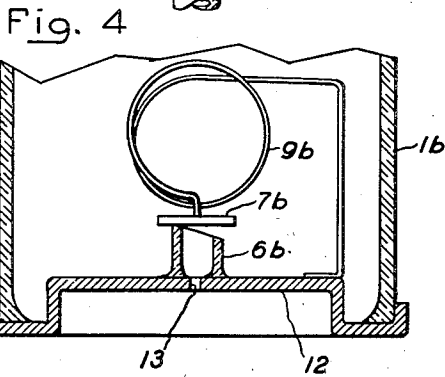
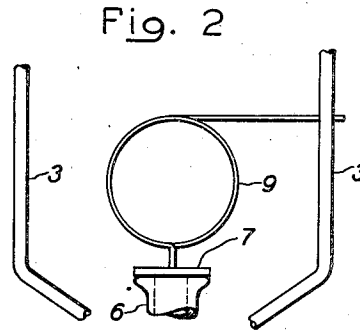
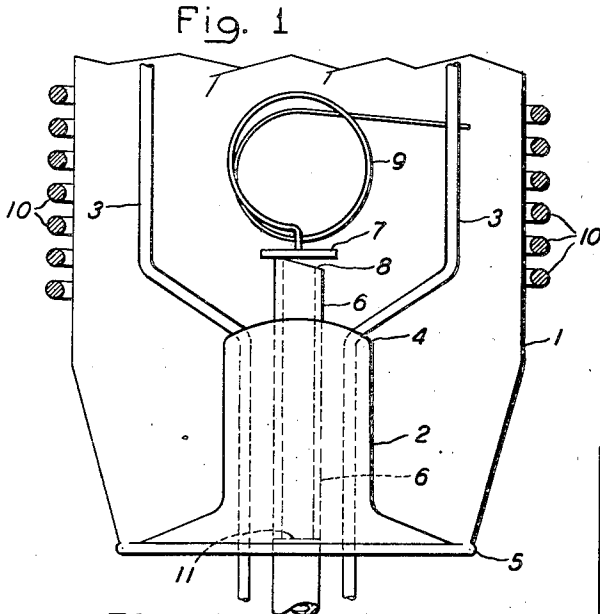

Inventor:
Paul O. Cartun,
by *John Anderson*
His Attorney.

UNITED STATES PATENT OFFICE

2,473,860

INTERNAL EXHAUST SEAL FOR ELECTRIC
LAMPS AND SIMILAR DEVICESPaul O. Cartun, Cleveland Heights, Ohio, assignor
to General Electric Company, a corporation of
New York

Application November 9, 1946, Serial No. 708,919

2 Claims. (Cl. 250—27.5)

1

This invention relates to seals for envelope openings or connections such as the exhaust tubes of incandescent lamps and electric discharge devices. The exhaust tubes of such devices are customarily closed and sealed outside the envelope, leaving an external tip that usually projects outward from the portion of the envelope to which the exhaust tube is attached.

Such an external tip or seal being sometimes undesirable, it is an object of my invention to provide a novel means of sealing which can be performed entirely inside the envelope, resulting in a seal that is wholly internal. Various novel features and advantages of the invention will appear from the following description of species thereof and from the drawing.

In the drawing, Fig. 1 is an elevation of one end of a lamp envelope, illustrating the sealing of its exhaust connection in accordance with my invention; Fig. 2 is a fragmentary view showing the completed seal; Fig. 3 is a view similar to Fig. 1 illustrating a modified form of the sealing structure; Figs. 4 and 5 are similar views illustrating the application of my invention in connection with envelopes of other types; and Fig. 6 is a fragmentary view of still another modification.

Fig. 1 illustrates the application of my invention to an electric lamp of one ordinary incandescent type such as shown in U. S. Patents Nos. 1,590,164 to Harrington et al. and 2,042,540 to Manders, although the invention is equally applicable to other types of lamps and electrical devices. In this case the end of the envelope 1 is closed by a flared glass stem 2 with leading-in wires 3, 3 sealed through a seal 4 at its upper or inner end and extending inward into the envelope to which the stem is sealed at 5. The filament connected between the current leads 3, 3 is not shown, nor any auxiliary supporting means for this filament. The seal 4 is shown as of an unpressed fused type such as illustrated in U. S. Patent No. 2,128,173 to White.

A small glass tube 6 generally corresponding to the exhaust connection in common use heretofore is sealed and open through the stem seal 4 and projects inward beyond this seal 4, as shown. The tube 6 is kept open by any suitable means while the end of stem tube 2 is being fused and sealed around and to it, as by a mandrel or pin inside said tube 6, as shown, for example, in U. S. Patent No. 1,491,436 to Strickland. After the mount including stem 2 has been sealed into the envelope 1, the connection afforded by the tube 6 may be used for exhausting air from the bulb,

2

or for filling the envelope with gas or other atmosphere, or both. Following this, it is desired to close and seal off the tube 6.

For this purpose, a thin disc-like sealing member or closure 7 is shown in Fig. 1 against the inner end or mouth 8 of the tube 6, preferably a disc of sheet metal like chrome iron such as that known as "Allegheny 55" which has the property of being wet by fused glass and sealing and adhering strongly thereto and has a coefficient of expansion similar to that of the glass. This member 7 is held in position opposite the mouth 8 by a support member 9 suitably attached to the lamp structure, leaving the mouth of the tube initially open for use, and capable of pressing the disc 7 against the said mouth of the tube to seal it thereto when the parts are heated. As shown, the open mouth end 8 of the tube 6 has an angular peripheral configuration, in this case biased and sloped away from the disc 7, which merely rests against the high side of the mouth. The support 9 preferably consists of a spring of fine wire such as molybdenum which retains its springiness under heat, and is looped or coiled in the general plane of the lamp axis, with one end secured (preferably welded) to the member 7 and the other end welded to a lead 3.

To close the mouth 8, after the lamp has been evacuated (and gas filled, if desired) by connecting the lower end of tube 6 to an exhaust pump, the disc 7 is heated by any suitable means, preferably an induction coil 10 temporarily placed around the envelope. The mouth 8 being also heated by radiation and conduction from the disc 7, it is fused and sealed to the said disc 7 which is pressed against it by the spring 9. Thus the connection 6 is closed and permanently sealed, the completed seal being shown in Fig. 2, after which the tube 6 may be severed at the line 11. The support member 9 may be constituted of a bi-metallic strip in which case it is pressed against the mouth 8 upon expansion due to the heating of the parts by coil 10.

The modification shown in Fig. 3 is the same as that shown in Fig. 1 except that the supporting member 9a for the disc 7 is in the form of a helical spring arranged concentric with the axis of the envelope 1 and the tube 6 to press the disc 7 against the said tube 6.

Fig. 4 illustrates the application of my invention to a lamp envelope 1b whose end wall is formed of an embossed sheet metal disc 12 that may be of chrome iron, as shown in my U. S. Patent No. 2,048,491. Here the exhaust tube 6b is shown as sealed by fusion to the inner side of

3

the disc 12 around a central hole 13 in this disc, and the coiled spring support 9b for the sealing member 7b is bent over and welded to the disc 12 near its edge.

Fig. 5 illustrates the application of the invention to a tubular lamp such as shown in my Patent No. 2,082,616, in a manner mainly similar to that shown in Fig. 4. The principal difference is that the spring support 9c for the sealing member 7c is bent in a reverse curve instead of into a coil, and is welded to a wire 14 forming part of the filament supporting structure extending from end to end of the lamp. Instead of a mere spring, the member 9c may be a bimetallic strip so that, upon heating, it firmly presses the disc 7c against the tube 6c extending from the metal end disc 11c.

In the modification of Fig. 1 shown in Fig. 6, the angular peripheral configuration of the mouth of the tube 6d consists of a notch or notches in the form of one or more V-shaped openings 8d. The closure disc 7d is carried by one end of a bimetallic strip 9d the other end of which is secured to a lead 3b and which, upon being heated by the disc 7d, is deformed to press the said disc firmly against the mouth of the tube 6d to seal it thereto, the finished seal being substantially the same as shown in Fig. 2.

This application is a continuation-in-part of my application Serial No. 580,742, filed March 3, 1945, now abandoned.

What I claim as new and desire to secure by Letters Patent of the United States is:

1. In an envelope having a reentrant glass exhaust tube extending thereinto, a sealing structure in said envelope comprising a closure disc of

4

metal adapted to fuse hermetically tight to glass, and a bimetallic support member carrying said disc and holding it adjacent the mouth of said tube in a position to leave the mouth open to the interior of the envelope and constructed and arranged to press the said disc against the said mouth of the tube to seal it thereto when the parts are heated.

2. In an envelope having a reentrant glass exhaust tube extending thereinto, the mouth of said tube having an angular peripheral configuration, a sealing structure in said envelope comprising a closure disc of metal adapted to fuse hermetically tight to glass, and a bimetallic support member carrying said disc and holding it against the mouth of said tube in a position to leave the mouth open to the interior of the envelope and constructed and arranged to press the said disc against the said mouth of the tube to seal it thereto when the parts are heated.

PAUL O. CARTUN.

REFERENCES CITED

The following references are of record in the file of this patent:

UNITED STATES PATENTS

Number	Name	Date
2,125,316	Ronci	Aug. 2, 1938

FOREIGN PATENTS

Number	Country	Date
111,419	Australia	Aug. 28, 1940
701,250	Germany	Jan. 11, 1941