



- (51) International Patent Classification:
E04H 3/16 (2006.01) E04H 4/16 (2006.01)
E04H 4/12 (2006.01)
- (21) International Application Number: PCT/US2014/031757
- (22) International Filing Date: 25 March 2014 (25.03.2014)
- (25) Filing Language: English
- (26) Publication Language: English
- (30) Priority Data: 14/023,415 10 September 2013 (10.09.2013) US
- (63) Related by continuation (CON) or continuation-in-part (CIP) to earlier application: US 14/023,415 (CIP) Filed on 10 September 2013 (10.09.2013)
- (71) Applicant: TOTALLY NEW TECHNOLOGIES LLC [US/US]; 107 Space Park North, Goodlettsville, Tennessee 37072 (US).
- (72) Inventor: SMITH, Ronnie E.; 107 Space Park North, Goodlettsville, Tennessee 37072 (US).
- (74) Agent: CORTESI, Shane V.; Totally New Technologies LLC, 107 Space Park North, Goodlettsville, Tennessee 37072 (US).
- (81) Designated States (unless otherwise indicated, for every kind of national protection available): AE, AG, AL, AM, AO, AT, AU, AZ, BA, BB, BG, BH, BN, BR, BW, BY, BZ, CA, CH, CL, CN, CO, CR, CU, CZ, DE, DK, DM, DO, DZ, EC, EE, EG, ES, FI, GB, GD, GE, GH, GM, GT, HN, HR, HU, ID, IL, IN, IR, IS, JP, KE, KG, KN, KP, KR, KZ, LA, LC, LK, LR, LS, LT, LU, LY, MA, MD, ME, MG, MK, MN, MW, MX, MY, MZ, NA, NG, NI, NO, NZ, OM, PA, PE, PG, PH, PL, PT, QA, RO, RS, RU, RW, SA, SC, SD, SE, SG, SK, SL, SM, ST, SV, SY, TH, TJ, TM, TN, TR, TT, TZ, UA, UG, US, UZ, VC, VN, ZA, ZM, ZW.
- (84) Designated States (unless otherwise indicated, for every kind of regional protection available): ARIPO (BW, GH, GM, KE, LR, LS, MW, MZ, NA, RW, SD, SL, SZ, TZ, UG, ZM, ZW), Eurasian (AM, AZ, BY, KG, KZ, RU, TJ, TM), European (AL, AT, BE, BG, CH, CY, CZ, DE, DK, EE, ES, FI, FR, GB, GR, HR, HU, IE, IS, IT, LT, LU, LV, MC, MK, MT, NL, NO, PL, PT, RO, RS, SE, SI, SK, SM, TR), OAPI (BF, BJ, CF, CG, CI, CM, GA, GN, GQ, GW, KM, ML, MR, NE, SN, TD, TG).

[Continued on next page]

(54) Title: POOL SKIMMER BASKET SYSTEM

FIG. 10

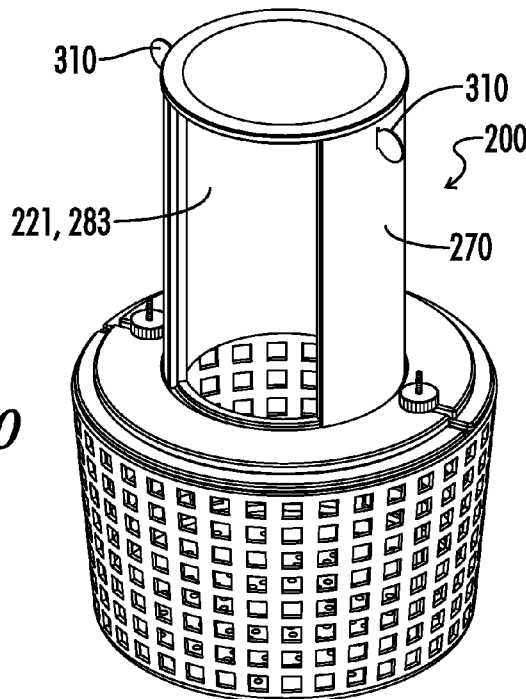

(57) Abstract: The present invention relates to apparatuses for improving pool skimmers. In some embodiments, the apparatus is a pool skimmer basket system that includes a skimmer basket, a first tube that is attached to the skimmer basket, and a second tube that is adjacent to and rotatable relative to the first tube. The first tube includes a longitudinal slot that feeds water into the skimmer basket. Without being bound by any particular theory, it is believed that the slot increases the velocity of water flowing into the basket and that the system increases the debris-holding capacity and allows one to avoid having to reach through dirty water to remove the skimmer basket.



Declarations under Rule 4.17:

— *of inventorship (Rule 4.17(iv))*

Published:

— *with international search report (Art. 21(3))*

INTERNATIONAL PATENT APPLICATION

POOL SKIMMER BASKET SYSTEM

5

BACKGROUND

TECHNICAL FIELD

[0001] The present invention relates to apparatuses for improving the operation of pool skimmers, particularly those used in swimming pools, and
10 methods of using the same.

BACKGROUND OF THE INVENTION

[0002] With reference to FIGs. 1-3, in the prior art, it is known to remove debris in swimming pools **110** through the use of skimmers **100**. Skimmers **100**
15 generally include a rectangular skimmer opening **135** located in a sidewall **120** of the swimming pool **110**, a moveable weir **170** that pivots on a hinge **155** within the skimmer **100** and moves in response to changes in the water levels of the swimming pool **110**, and a skimmer basket **160**. The skimmer basket **160** sits in a well **198** located in the interior **137** of the skimmer **100**, collects debris and must be emptied.

20 [0003] Water enters the skimmer **100** through the opening **135**, flows through water passageway **196** and over the weir **170**, and through the skimmer basket **160**. Ultimately, the filtered water is then pumped back into the swimming pool **110** through water jets **175** located in the pool sidewalls **120** using a pump **190** and a series of pipes **180**, **181**, **182** and **193**. The capacity of pool pumps **190** is usually

provided in gallons per minute (gpm), which refers to the amount of water that the pump **190** is able to circulate in a minute. The pump **190** is usually connected to a pool drain **195** in addition to the skimmer **100**, and in some cases the pool owner is able to adjust the rate at which the pump **190** pulls water into the skimmer **100** by closing the drain valve **194**. However, closing the drain valve **194** requires manual intervention by the pool owner.

[0004] Unfortunately, swimming pool skimmers **100** have a number of problems. First, skimmer baskets **160** fill up quickly, particularly in residential areas with many trees. Thus, skimmer baskets **160** are a constant maintenance issue. Second, skimmer baskets **160** are often located more than six inches below the top access opening **197** to the skimmer **100**, which means that the pool owner has to dip his or her hands into dirty water to reach the skimmer basket **160**. This is particularly unappealing since creatures like snails and spiders are attracted to skimmers **110**. Third, many swimming pool pumps **190** lack sufficient suction force due to safety requirements such as the Virginia Graeme Baker Pool and Spa Safety Act in the United States. Consequently, too often debris water is sucked into the skimmer **100** at too low of a rate, leaving the pool **110** dirty. Finally, skimmer baskets **160** are often provided with a plastic handle **166** so that they may be emptied. However, when a large amount of water-logged, heavy debris is located above the handle **166**, the pump **190** sucks the water-logged debris against the handle **166**, leading the handle **166** to snap (break). This is especially problematic in the case of cheap plastic baskets **160** with weak handles **166**.

[0005] Attempts have been made in the prior art to address some of these issues. For example, U.S. Patent No. 8,202,416 teaches a diverter plate that

replaces the existing weir **170** and consists of two parts that move into the skimmer **100**. Although the diverter plate of the '416 patent claims to increase suction power, it does nothing to address the lack of capacity of the skimmer basket **160**, the fact that a pool owner has to dip his or her hands into dirty water to remove the
5 skimmer basket **160**, or breakage of basket handles **166**.

[0006] U.S. Patent No. 5,830,350 teaches a vented tower that extends from the floor **161** of the skimmer basket **160** and seeks to address a particular problem associated with the skimmer basket **160**, namely, the basket **160** being sucked to the skimmer well **198** by the pump **190**. The '350 patent does nothing to address
10 the small capacity of the skimmer basket **160**, as the vents in the tower are air vents. The '350 patent also does not address the flow rate of water into the basket **160**.

[0007] Skimmer baskets with floating weirs have also been developed, as described in for example U.S. Patent Nos. 6,716,342 and 4,325,150. These baskets
15 are designed to prevent water from flowing back into the pool **110** from the skimmer **100** and are not designed to increase basket **160** capacity, make the basket **160** easier to grab, or to increase the velocity of water and debris entering the basket **160**.

[0008] Finally, U.S. Patent No. 4,737,279 ("the '279 patent") teaches an
20 apparatus that sits on top of a skimmer basket and has two flow paths, one via a coupling for a suction hose and the other via a weir-gated enclosure carried by the basket closure. The '279 patent does not teach or suggest a system that has an inner and outer tube that are attached to a skimmer basket. The '279 patent also teaches that the proper position of the apparatus is the position in which the open

weir gated side of the enclosure faces toward the skimmer throat. See Column 8, Lines 37-40; Figure 1.

[0009] Thus, there is a need for cheap and safe devices that improve the operation of swimming pool skimmers.

5 BRIEF SUMMARY

[0010] The present invention relates to apparatuses for improving pool skimmers. In some embodiments, the apparatus is a pool skimmer basket system that includes a skimmer basket, a first tube, and a second tube. More particularly, in some embodiments, the system includes a skimmer basket, the skimmer basket
10 configured to be placed in a pool skimmer and comprising a basket interior, a basket exterior, a floor, a top/rim, a height extending from the floor to the top/rim, a sidewall extending upwardly from the floor, and a plurality of apertures located in at least one of the basket sidewall and the floor (i.e., in the sidewall and/or floor), wherein the basket floor and the basket sidewall separate the basket interior from
15 the basket exterior; a first tube attached to the skimmer basket, the first tube comprising a top, a bottom comprising an opening, a first tube height extending from the bottom to the top, an interior, an exterior comprising a first flange extending from the first tube towards the basket sidewall, and a first tube slot configured to feed water from the first tube exterior to the first tube interior and
20 ultimately the basket interior, the first tube slot located between the top and the bottom of the first tube, the first tube slot having a width perpendicular to the first tube height and a height parallel to the first tube height; and a second tube adjacent to the first tube and rotatable relative to the first tube, the second tube comprising a top, a bottom, a second tube height extending from the bottom to the

top, and a second tube slot located between the top and the bottom of the second tube, the second tube slot having a width perpendicular to the second tube height and a height parallel to the second tube height.

[0011] Optionally, the tops of the first and second tubes each comprise
5 openings. Optionally, the first tube is located inside the second tube interior. Optionally, the system further includes a pool, the pool comprising a sidewall, the pool sidewall comprising a pool skimmer, the pool skimmer comprising a skimmer interior and a skimmer opening leading from the pool to the skimmer interior and further wherein the basket is located in the skimmer interior. Optionally, the
10 widthwise center of the first tube slot is offset from the widthwise center of the skimmer opening by at least about 30 degrees. Optionally, the first flange and the skimmer basket are permanently attached to each other. Optionally, the first flange and the skimmer basket are mechanically/removably attached to each other. Optionally, the first flange is pivotally attached to the skimmer basket by a hinge.
15 Optionally, the first flange is removably attached to the skimmer basket by a fastener. Optionally, the fastener is at least about 3 inches in length and comprises threads. Optionally, the first flange comprises a first fastener aperture and the fastener passes through the first fastener aperture. Optionally, the first fastener aperture substantially extends to an outer edge of the first flange. Optionally, the
20 fastener passes through an aperture in the basket. Optionally, the first flange and the basket comprise mating threads for removably attaching the first flange to the basket. Optionally, the width of the first tube slot is at least about 1 inch, the width of the second tube slot is at least about 1 inch, the height of the first tube slot is at least about 4 inches and the height of the second tube slot is at least about 4 inches.

Optionally, the first tube and the second tube are generally cylindrical. Optionally, the first tube height is greater than the second tube height, the second tube is located above the first flange and the first tube comprises an upper flange that extends about a circumference of the first tube, the upper flange located above the first flange and the second tube. Optionally, the first flange comprises a groove that is adjacent to the first tube, is located on the top surface of the first flange, and extends about a perimeter of the first tube, and the bottom of the second tube is located in the groove. Optionally, the first tube slot comprises a top and a bottom, and the bottom of the first tube slot is adjacent to a top of the first flange.

Optionally, the system further comprises a washer attached to the first flange, the washer comprising a washer opening in fluid communication with the first tube bottom aperture. Optionally, the washer comprises a fastener slot configured to receive a fastener and the washer extends beyond a perimeter of the first flange. Optionally, the first tube slot extends from the first flange to the top of the first tube. Optionally, the first tube is immobile relative to the first flange and the basket. Optionally, the first tube, second tube, and first flange are comprised of plastic. Optionally, the width of the first tube slot is approximately equal to the width of the second tube slot. For example, the width of the first tube slot may be between about 90% and about 110% of the width of the second tube slot. Optionally, the interior of the first tube is hollow. Optionally, the first tube is located above the basket floor. Optionally, the height of the first tube is different than the height of the second tube. Optionally, the second tube comprises at least one additional aperture between the top and the bottom of the second tube, the at least one additional aperture generally opposite the second tube slot. Optionally, the first

flange is adjacent to the top of the skimmer basket. Optionally, the first tube extends above and below the first flange. Optionally, the first flange is configured to inhibit (but not necessarily prevent) water from entering the basket without first entering the slot of the first tube. Optionally, the first tube height is at least about 5 4 inches. Optionally, the bottom of the basket is substantially flat. Optionally, the first tube is configured to increase the velocity of water (e.g., create a vortex) entering into the basket when the basket is placed in a swimming pool skimmer and the swimming pool skimmer is connected to a pump.

[0012] Optionally, the system is provided as a kit that includes a first tube, 10 the first tube comprising a top, a bottom comprising an opening, a height extending from the bottom to the top, an interior, an exterior, an inner diameter perpendicular to the height, an outer diameter perpendicular to the height, a first tube slot having a width of at least about 1 inch and a height of at least about 4 inches, the first tube slot width parallel to the inner and outer diameters, the first tube slot height 15 perpendicular to the first tube inner and outer diameters, the first tube exterior comprising a first flange extending from the first tube, the first flange configured to attach to a skimmer basket, at least one of the first tube (e.g., the wall forming the first tube or a ledge extending from the interior surface of the wall) and the first flange comprising a plurality of fastener apertures for attaching the first tube to a 20 skimmer basket; and a second tube, the second tube comprising a top, a bottom comprising a bottom aperture, a height extending from the bottom to the top, an interior, an exterior, an inner diameter perpendicular to said height, an outer diameter perpendicular to said height, and a second tube slot having a width of at least about 1 inch and a height of at least about 4 inches, the second tube slot width

parallel to the second tube inner and outer diameters, the second tube slot height perpendicular to the second tube inner and outer diameters. Optionally, the inner diameter of the first tube is different than the inner diameter of the second tube and the outer diameter of the first tube is different than the outer diameter of the second tube. 5
Optionally, the inner diameter of the second tube is substantially equal to the outer diameter of the first tube so that when the second tube is placed over the first tube, the second tube fits tightly on the first tube. Optionally, the first flange comprises a groove adjacent to the first tube and extending about an outer circumference of the first tube. Optionally, the kit further includes an upper flange 10
extending about an outer circumference of the first tube. Optionally, the first flange substantially surrounds an outer circumference of the first tube. Optionally, the first tube is located between the fastener apertures. Optionally, the kit further includes a washer configured to attach to the first flange, the washer comprising a washer opening and the washer has a width/diameter of at least about 6 inches 15
(e.g., about 6 inches to about 14 inches). Optionally, the washer comprises a fastener slot and the fastener slot substantially extends to an outer edge of the washer. Optionally, the kit further comprises two threaded fasteners, the fasteners each having a length of at least about 3 inches. Optionally, the interior of the first tube is hollow. Optionally, the tops of the first and second tube each comprise a top 20
aperture.

[0013] In one particular embodiment, the system includes: a pool skimmer, the pool skimmer comprising a skimmer interior, a skimmer exterior, a skimmer opening leading from the skimmer exterior to the skimmer interior; a skimmer basket disposed in the pool skimmer interior, the skimmer basket comprising a

basket interior, a basket exterior, a floor, a top/rim, a height extending from the floor to the top/rim, a sidewall extending upwardly from the floor, and at least one aperture located in at least one of the basket sidewall and the floor, wherein the basket floor and the basket sidewall separate the basket interior from the basket exterior; a first tube located above the skimmer basket, the first tube comprising a top, a bottom comprising an opening, a first tube height extending from the bottom to the top, an interior, an exterior, and a first tube slot configured to feed water from the first tube exterior to the first tube interior and ultimately the basket interior, the first tube slot located between the top and the bottom of the first tube, the first tube slot having a width perpendicular to the first tube height and a height parallel to the first tube height; and a door adjacent to the first tube, the door configured to move horizontally relative to the first tube and at least partially cover the first tube slot. In some embodiments, the door is a second tube, the second tube configured to rotate relative to the first tube and at least partially cover the first tube slot, the second tube comprising a top, a bottom, a second tube height extending from the bottom to the top, and a slot located between the top and the bottom of the second tube, the second tube slot having a width perpendicular to the second tube height and a height parallel to the second tube height. Optionally, the system further includes a pump in fluid communication with the skimmer basket, a pool and a pool sidewall and the skimmer is attached to, or located inside, the basket sidewall.

[0014] Preferably the system is used in a method of increasing the velocity of water flowing into a skimmer basket that includes a) providing the system and b) flowing water and debris through the slot of the second tube, through the slot of the

first tube, into the first tube interior, and into the skimmer basket interior. Optionally, the method further includes rotating the second tube relative to the first tube. Optionally, the method further includes the step of rotating the second tube relative to the first tube so that the second tube partially covers the first tube slot, and rotation of the second tube relative to the first tube so that the second tube partially covers the first tube slot increases the velocity of water and debris entering the basket.

[0015] In yet another embodiment, the system includes a pool skimmer system comprising a pool skimmer, the pool skimmer comprising a skimmer interior, a skimmer exterior, a skimmer opening leading from the skimmer exterior to the skimmer interior, a skimmer basket well located in the skimmer interior, and a water passageway leading to the skimmer basket well, the water passageway having a height and a width; a skimmer basket disposed in the skimmer basket well, the skimmer basket comprising a basket interior, a basket exterior, a floor, a top/rim, a height extending from the floor to the top/rim a sidewall extending upwardly from the floor, and at least one aperture located in at least one of the basket sidewall and the floor, wherein the basket floor and the basket sidewall separate the basket interior from the basket exterior; a tube located above the skimmer basket, the tube comprising a top, a bottom comprising an opening, a tube height extending from the bottom to the top, an interior, an exterior, and a tube slot configured to feed water from the tube exterior to the tube interior and the basket interior, the tube slot located between the top and the bottom of the tube, the tube slot having a width perpendicular to the tube height and a height parallel to the tube height, the tube adjacent to the water passageway, the tube configured to

rotate relative to the water passageway and at least partially cover the water passageway. Optionally, the tube is attached to the skimmer basket. Optionally, the system further includes a pump in fluid communication with the skimmer basket, a pool and a pool sidewall and the skimmer is attached to, or located inside, the basket sidewall. Optionally, the water passageway has a width of at least about 2 inches and a height of at least about 4 inches. Optionally, the tube is generally cylindrical. Optionally, the system further includes a weir located in the water passageway, the weir moveable between a vertical position in which the weir is parallel to the water passageway height and a horizontal position in which the weir is parallel to the water passageway width.

BRIEF DESCRIPTION OF THE DRAWINGS

[0016] FIG. 1 illustrates a front, perspective view of a prior art skimmer and pool sidewall.

[0017] FIG. 2 illustrates a cross-sectional view of the prior art skimmer of FIG. 1, taken along line 2-2 of FIG. 1.

[0018] FIG. 3 illustrates a schematic view of water circulating in a clockwise fashion in a swimming pool with a prior art skimmer.

[0019] FIG. 4 illustrates a front, perspective, exploded view of a skimmer basket system of one embodiment of the present invention; in this embodiment, the first flange of the basket system is removably attached to the basket by a fastener.

[0020] FIG. 5 illustrates a front, perspective view of the assembled basket system of FIG. 4.

[0021] FIG. 6 illustrates a close-up, perspective view of the circled area of FIG. 5.

[0022] FIG. 7 illustrates a side, elevation view of the assembled basket system of FIG. 4.

5 [0023] FIG. 8 illustrates a section view of the basket system of FIG. 7, taken along line 8-8.

[0024] FIG. 9 illustrates a front, perspective, exploded view of a skimmer basket system of another embodiment of the present invention; in this embodiment the first flange of the basket system is removably attached to the basket by a
10 fastener and the system further includes a groove and an upper flange to guide the second tube as it slides around the first tube.

[0025] FIG. 10 illustrates a front, perspective view of the assembled basket system of FIG. 9.

[0026] FIG. 11 illustrates a rear, perspective view of the assembled basket
15 system of FIG. 9.

[0027] FIG. 12A illustrates a front, perspective view of the first tube of the basket system of FIG. 9.

[0028] FIG. 12B illustrates a front, perspective view of a first tube with a small lip surrounding the bottom opening.

20 [0029] FIG. 13 illustrates a side, elevation view of the assembled basket system of FIG. 9.

[0030] FIG. 14 illustrates a section view of the basket system of FIG. 13, taken along line 14-14.

[0031] FIG. 15 illustrates a front, perspective, exploded view of a skimmer basket system of another embodiment of the present invention; in this embodiment, the first tube includes two ledges that receive bolts to attach the first tube to the skimmer basket.

5 [0032] FIG. 16 illustrates a front, perspective view of the assembled skimmer basket system of FIG. 15.

[0033] FIG. 17 illustrates a close-up, perspective view of the circled area of FIG. 16.

[0034] FIG. 18 illustrates a side, elevation view of the assembled basket
10 system of FIG. 16.

[0035] FIG. 19 illustrates a section view of the basket system of FIG. 18, taken along line 19-19.

[0036] FIG. 20 illustrates a front, perspective, exploded view of a skimmer basket system of another embodiment of the present invention; in this embodiment,
15 the first tube includes two posts that receive O-rings to attach the first tube to the skimmer basket handle.

[0037] FIG. 21 illustrates a front, perspective view of the assembled basket system of FIG. 20.

[0038] FIG. 22 illustrates a section view of the basket system of FIG. 21,
20 taken along line 22-22.

[0039] FIG. 23 illustrates a front, perspective, exploded view of a skimmer basket system of another embodiment of the present invention; in this embodiment, the first flange includes male threads that mate with female threads on the interior of the skimmer basket.

[0040] FIG. 24 illustrates a front, perspective view of the assembled basket system of FIG. 23.

[0041] FIG. 25 illustrates a bottom view of the first flange and first tube of the basket system of FIG. 23.

5 [0042] FIG. 26 illustrates a front, perspective, exploded view of a skimmer basket system of another embodiment of the present invention; in this embodiment, the first flange is attached to the basket via two hinges.

[0043] FIG. 27 illustrates a side, elevation view of the assembled basket system of FIG. 26.

10 [0044] FIG. 28 illustrates a side, elevation view of the assembled basket system of FIG. 26; in FIG. 28, one of the hinge pins has been removed so that the basket can pivot about the other hinge pin.

[0045] FIG. 29 illustrates a front, perspective view of the assembled basket system of FIG. 26.

15 [0046] FIG. 30 illustrates a close-up, perspective view of the circled area of FIG. 29.

[0047] FIG. 31 illustrates a front, perspective view of the assembled basket system of FIG. 26; in FIG. 31, one of the hinge pins has been removed so that the basket can pivot about the other hinge pin.

20 [0048] FIG. 32 illustrates a top view of the assembled basket system of FIG. 26.

[0049] FIG. 33 illustrates a top view of a skimmer with the assembled basket system of FIG. 26; in FIG. 33, the top access opening has been removed so that the basket system is visible.

[0050] FIG. 34 illustrates a front, perspective view of a skimmer basket system of another embodiment of the present invention; in this embodiment, the basket, first flange, and first and second tubes are a single piece.

[0051] FIG. 35 illustrates a front, perspective view of a skimmer that includes
5 a tube that is configured to rotate within the skimmer so as to at least partially cover the water passageway.

[0052] FIG. 36 illustrates a side view of a skimmer that is attached to the sidewall of a swimming pool; the skimmer has a longitudinal slot in the housing and the skimmer interior has a tube that is configured to rotate to partially cover the
10 longitudinal slot.

DETAILED DESCRIPTION

[0053] The present disclosure provides a system **200** for improving a pool skimmer **100**. In the drawings, not all reference numbers are included in each
15 drawing for the sake of clarity. It will be understood that references herein to the singular form of a term encompass plural forms. The system **200** may be used in conjunction with any suitable pool skimmer, and are preferably used with immobile skimmers that are located in swimming pool, pond, fountain, or spa sidewalls, such as the skimmer **100** illustrated in FIGs. 1-3. As used herein, the term “pool” means
20 a swimming pool, pond, fountain or spa. While, the system **200** may be used in spas, it will be appreciated that the system **200** is preferably used in swimming pools, given that spas generally have a small surface area and collect less debris than pools.

[0054] Referring further to the system **200**, as shown in FIGs. 4-36 the system **200** includes a skimmer basket **160** configured to be placed in the interior **137** of a pool skimmer **100**. The skimmer basket has a basket interior **167**, a basket exterior **168**, a floor **161**, a top/rim **162**, a height **165** extending from the floor **161** to the top/rim **162**, one or more sidewalls **163** extending upwardly from the floor **161**, and a plurality of apertures **164** located in the floor **161** and/or the sidewalls **163**. The basket floor **161** and the basket sidewall **163** separate the basket interior **167** from the basket interior **168**. In some embodiments, the basket **160** is generally cylindrical with the diameter of the cylinder decreasing from the top **162** to the floor **161** (e.g., a slight taper). In some embodiments, the basket floor **161** is substantially flat. However, the basket **160** can be any other suitable shape, such as rectangular. In some embodiments, the floor **161** is substantially flat.

[0055] The system **200** further includes a first tube **210** that, when the system **200** is fully assembled, optionally attaches to the skimmer basket **160** and is located above the basket floor **161**. The first tube **210** optionally includes a wall **211** that forms the first tube **210**, a top **214**, a bottom **216** that includes a bottom opening **217**, a first tube height **218** extending from the bottom **216** to the top **214**, an interior **212**, an exterior **213** that includes a first flange **230** extending from the wall **211** towards the basket sidewall **163**, and a first tube longitudinal slot **221**. In some embodiments, as shown in FIGs. 4, 5, 9, 10, 12A, 15, 16, 20-24, 26, 29, 31, 34, 35, there is no lip surrounding the bottom opening **217** so that the bottom opening **217** extends to the wall **211** forming the first tube **210**. In other embodiments, as shown in FIG. 12B, a small lip **225** surrounds the bottom opening **217** and the bottom opening **217** has a width/diameter **226** of from about 3 to about 4 inches. In

use, water and debris from the first tube exterior **213** enters the first tube interior **212** through the first tube longitudinal slot **221**, flows through the bottom opening **217** and enters the basket interior **167**. Optionally, the top **214** of the first tube **210** includes a top opening **215** so that water and debris may enter the inner tube interior **212** through the top opening **215** when water and debris are located above the top **214** of the first tube **210**, which may occur when, for example, the water level in the skimmer **100** is particularly high. The first tube slot **221** preferably extends substantially the entire height **218** of the first tube **210**. Preferably, the first tube height **218** is at least about 4 inches (e.g., about 4 inches to about 15 inches). Preferably, the first tube slot **221** has a width **222** perpendicular to the first tube height **218** and a height **224** parallel to the first tube height **218**. In some embodiments, the first tube slot **221** has a width **222** of at least about 1 inch (more preferably about 2 to about 5 inches) and a height **224** of at least about 1 inch (more preferably about 4 inches to about 15 inches, even more preferably about 6 inches to about 9 inches). For example, the first tube slot may have an average width **222** of about 1 inch to about 3.5 inches, even more preferably about 1 inch to about 3 inches, and even more preferably about 2 inches to about 3 inches). Preferably, the first tube **210** is generally cylindrical and the first tube **210** has an inner diameter **255** (measured as the distance between opposing interior surfaces of the wall **211**) and an outer diameter **254** (measured as the distance between opposing exterior surfaces of the wall **211**) of at least about 2 inches (more preferably, about 3 inches to about 9 inches). In some embodiments, the first tube **210** is generally cylindrical with the inner and outer diameters **254** and **255** of the cylinder gradually increasing from the top **214** to the bottom **216** (e.g., a slight taper) to facilitate

injection of the first tube **210** during plastic injection molding. The first tube wall **211** may have any desired thickness **258** depending on the strength desired and the cost of the material. In some embodiments, the first tube wall thickness **258** is from about 0.05 inches to about 2 inches. Optionally, the first tube **210** includes a
5 knurled surface **252** at the top **214** of the first tube **210** for gripping. Preferably, the bottom **290** of the first tube slot **221** is adjacent to (more preferably about co-planar with) the top **231** of the first flange **230**, as shown in FIGs. 4, 5, 8, 9, 10, 13-16, 18-24, 26, 29, 31 and 34. Preferably, the first tube slot **221** extends from the first flange **230** to the top **214** of the first tube **210**. Preferably, the first tube **210** is
10 immobile relative to the first flange **230**.

[0056] In some embodiments, the first flange **230** is configured so that it alone, or in combination with a washer **260**, inhibits (but does not necessarily prevents) water and debris from entering the basket **160** without first entering the slot **221** of the first tube **210**. To accomplish this, the first flange **230** alone, or the
15 first flange **230** and the washer **260**, extends to or beyond the sidewall **163** of the basket **160** when the basket **160** is placed in the well **198** of the skimmer **100**. The first flange **230** and, if included, the first flange **230** and the washer **260**, are preferably adjacent to the top **162** of the skimmer basket **160**. The purpose of the washer **260** is that it may be desirable to provide a universal basket system **200**
20 that works with a number of different sized skimmer baskets **160** and the washer **260** allows the system **200** to be used with larger skimmer baskets **160** and, in combination with the first flange **230**, the washer **260** substantially creates a seal to force water and debris into the slot **210**. In some embodiments, the length **233** and width **256** of the first flange **230** (i.e., the diameter of the first flange **230** if the first

flange **230** is circular) is at least about 4 inches (e.g., about 4-10 inches) and the length **261** and width **268** of the washer **260** (i.e., the diameter of the washer **260** if the washer **260** is circular) is larger than the length **233** and width **256** of the first flange **230** – e.g., about 6 to about 14 inches – so that the washer **260** extends
5 beyond the perimeter of the first flange **230**. The first flange **230** and washer **260** can be any suitable shape, including generally circular and generally rectangular, depending on the shape of the basket **160**. If included, the washer **260** includes a central opening **262** that is substantially aligned with the bottom hole **217** of the first tube **210** such that water and debris flows through the first slot **221**, through
10 the bottom hole **217**, through the washer hole **262** and into the skimmer basket interior **167**. In some embodiments, the washer hole **262** has a width/diameter **269** of from about 3 inches to about 6 inches. If included, the washer **260** may be placed above or below the first flange **230**. Preferably, the washer **260** is placed below the first flange **230** and the first tube **210** extends below the first flange **230** to assist in
15 the positioning of the washer **260**, as best seen in FIGs. 19 and 25, 28. It will be understood that the first flange **230** and washer **260** inhibit but do not necessarily prevent water and debris from entering the basket interior **167** without first entering the slot **221** of the first tube **210** because the first flange **230** and washer **260** may each comprise small fastener apertures **237** and **263** as described below
20 and water and debris may enter the top opening **215** of the first tube **210** if the water level in the skimmer **135** is high, as described above.

[0057] The purpose of using the first flange **230** alone or in combination with the washer **260** to inhibit water and debris from entering the basket **160** without first entering the slot **221** of the first tube **210** is that skimmer baskets in the prior

art without the system **200** often lack a pump with sufficient force to pull debris and water into the skimmer basket. However, by providing a first tube **210** with the slot **221**, the present invention is able to take advantage of the Bernoulli principle, which holds that velocity of water increases when water flows through a narrow constriction. Thus, by constricting the flow of the water and debris into the basket **160** using the first tube slot **221**, it has been observed that water and debris flows into the basket **160** at a higher rate than without the system **200**. It has also been observed that offsetting the widthwise center **223** of the slot **221** from the widthwise center **136** of the skimmer opening **135** increases the flow of water and the debris into the basket **160** because the offset requires water and debris to travel around the first tube **210**, like water drawing in a toilet, before entering the slot **221**. For example, if the widthwise center **136** of the skimmer opening **135** is assigned the 6 o'clock position, it has been observed that positioning the widthwise center **223** of the slot **221** at the 2 o'clock position is optimal in pools **110** that have a clockwise drain bias in the skimmer **100**. See Figure 33. It would be deduced that positioning the slot **221** at the 10 o'clock position would be optimal in pools **100** that have clockwise drain bias in the skimmer **100**. Preferably, the widthwise center **223** of the slot **221** is offset from the widthwise center **136** of the skimmer opening **135** by at least about 30 degrees (e.g., about 30 degrees to about 330 degrees – i.e., between the 7 o'clock and 5 o'clock positions if the widthwise center **136** of the skimmer opening **135** is assigned the 6 o'clock position).

[0058] The system **200** further includes a door configured to move horizontally and partially cover the first tube longitudinal slot **221**. In some embodiments, the door is a second tube **270** adjacent to the first tube **210** and

rotatable relative to the first tube **210**. The second tube **270** includes a wall **276** that forms the second tube **270**, an interior **281**, an exterior **282**, a top **271**, a bottom **274** that includes a bottom opening **273**, a second tube height **275** extending from the top **271** to the bottom **274**, and a second tube longitudinal slot **283** located
5 between the top **271** and the bottom **274** of the second tube **270**. Preferably, the second tube slot **283** has a width **285** perpendicular to the second tube height **275** and a height **284** parallel to the second tube height **275**. Preferably, the top **271** includes a top opening **272**. A function of the second tube **270** is that the second tube **270** can be rotated relative to the first tube **210** to partially cover the first tube
10 slot **221** to increase the velocity of water and debris flowing into the skimmer basket **160** and another function is that the second tube **270** can be rotated relative to the first tube **210** to close the first tube slot **221** when a user desires to remove the system **200** from the skimmer interior **137** in order to remove debris from the first tube **210** and the skimmer basket **160** (i.e., empty the first tube **210** and the
15 skimmer basket **160**). It has been observed that the velocity of water entering skimmer baskets **160** varies depending on pump **190** horsepower and whether the pump **190** has been recently cleaned. Thus, the second tube **270** allows a pool owner to rotate the second tube **270** relative to the first tube **210** to partially cover the first tube slot **221** when the owner has a weak pump **190** and/or a pump system
20 that has not been recently cleaned (so as to increase the velocity of water and debris entering the skimmer basket **160**) and to leave the first tube slot **221** uncovered (i.e., leaving the first and second tube slots **221** and **283** aligned, as shown in FIGs. 5, 10, 16, 21, 24, 29, 31 and 34) when the owner has a strong pump **190** and/or a pump system that has been recently cleaned. Preferably, the second tube **271** has

one or more apertures **280** opposite the second tube slot **283**, which saves material cost, provides flexibility to the second tube **270**, and allows the manufacturer to include graphics such as the product's name, as shown in FIG. 11. In some embodiments, the second tube slot **283** has a width **285** of at least about 1 inch
5 (more preferably about 2 to about 5 inches) and a height **284** of at least about 1 inch (more preferably about 4 inches to about 15 inches). Preferably, the second tube slot **283** has the same size and shape as the first tube slot **221**. Preferably, the second tube **270** is generally cylindrical and the second tube **270** has an inner diameter **277** (measured as the distance between opposing interior surfaces of the
10 wall **276**) and an outer diameter **278** (measured as the distance between opposing exterior surfaces of the wall **276**). Preferably, the second tube inner diameter **277** is between 100 and 110% of the size of the first tube outer diameter **254** so that the second tube **270** hugs the first tube **210**. In other words, preferably the connection is tight enough so that both tubes **210** and **270** move vertically when a user lifts the
15 system **200** out of the skimmer **100** to empty the basket **160** but the user is able to rotate the second tube **270** relative to the first tube **210** to open and close the slot **221**. In some embodiments, the second tube inner diameter **277** and the second tube outer diameter **278** are at least about 2 inches (more preferably, about 3 inches to about 9 inches). Preferably, if the first tube **210** is tapered, as described above,
20 the second tube **270** has a similar taper. The second tube wall **276** may have any desired thickness **286** depending on the strength desired and the cost of the material. In some embodiments, the second tube wall thickness **286** is from about 0.05 inches to about 2 inches. In some embodiments, as shown in FIGs. 9, 10, and 12, the top surface **231** of the first flange **230** includes a groove **235** that extends

around a perimeter **219** of the first tube **210** (more particularly, the circumference of the first tube **210** if the first tube **210** is cylindrical) to create a track for the second tube **270**. In some embodiments, the width **236** of the first flange groove **235** is from about 100% to about 120% of the second tube wall thickness **286** so that the bottom **274** of the second tube **270** fits snugly in the groove **235**. In some 5 embodiments, as shown in FIGs. 10, 11, 13 and 14, the first tube **210** includes an upper flange **220** and the second tube is located between the first flange **230** and the upper flange **220**. In such embodiments, the first tube height **218** is greater than the second tube height **275**. Optionally, the second tube **270** includes a plurality of protrusions/ears **310** located at the top of the second tube **270** to make it 10 easier for a user to rotate the second tube **270**.

[0059] In some embodiments, the first tube **210** is located inside the second tube interior **281**, as shown in FIGs. 5, 7, 8, 10, 11, 13, 14, 16, 18, 19, 21, 22, 24, 27, 28, 29, and 31-34. In such embodiments, the inner diameter **255** of the first tube 15 **210** is different than the inner diameter **277** of the second tube **270** and the outer diameter **254** of the first tube **210** is different than the outer diameter **278** of the second tube **270**. Preferably, the first tube interior **212** is hollow. In other embodiments, the second tube **270** is located in the first tube interior **212**.

[0060] Preferably, the first tube **210**, the second tube **270**, the washer **260** and 20 the first flange **230** are comprised of plastic.

[0061] In some embodiments, the first flange **230** and the skimmer basket **160** are permanently attached to one another and the first and second tubes **210** and **270**, first flange **230**, and skimmer basket **160** are a single piece of plastic, as shown in FIG. 34.

[0062] In other embodiments, the first flange **230** and the skimmer basket **160** are mechanically attached to one another. For example, the system **200** may include two hinge pins **250** and two hinges **249** so that the basket **160** can pivot relative to the first flange **230** upon removal of one of the hinge pins **250**, as shown in FIGs. 26-33. In other embodiments, as shown in FIGs. 23-25, the first flange **230** and the inner rim of the basket **160** include mating threads **245** and **246** so that the first flange **230** can removably attach to the basket **160**. In such embodiments, the washer **260** may include threads **266** that mate with threads **246** located in the inner rim of the basket **160** and the bottom surface **232** of the first flange **230** may include one or more protrusions **264** that mate with and lock into apertures **263** in the washer **260** so that the washer **260** is removably attached to the first flange **230**. In some embodiments, the first flange **230** and the skimmer basket **160** may be removably attached by a fastener **238**. In some such embodiments, as shown in FIGs. 4-19, the fastener **238** includes a series of bolts **239**, washers **242**, and nuts **243**. In some embodiments, the bolt **239** includes threads **240** and the bolt **239** passes through the apertures **164** located in the floor **161** of the basket **160**. Preferably, the bolt **239** has a length **241** of at least 3 inches (e.g., about 3 to about 12 inches). Preferably, the top end **257** of the bolt **239** passes through one or more fastener apertures **237** located in the first flange **230** and one or more fastener apertures **263** located in the washer **260**. Preferably, the washer fastener apertures **263** substantially extend to the outer edge **265** of the washer **260** and the first flange fastener apertures **237** substantially extend to the outer edge **244** of the first flange **230** which makes the system **200** easy to assemble. Alternatively, instead of a bolt **239**, the system **200** may include a threaded rod that has a nut **243** and

washer **242** at each end. In other embodiments, the interior **212** of the first tube **210** includes a ledge **253** and the top end **257** of the bolt **239** passes through an aperture located in the ledge **253**, as seen in FIGs. 15-19. It has been observed that a stainless steel threaded rod or bolt **239** having 4-40 thread is particularly well-suited for use with the present system **200**. In other embodiments, instead of a bolt **239** or threaded rod, the fastener **218** may be an O-ring **248** that attaches to a post **247** located in the first tube interior **212**, as shown in FIGs. 20-22.

[0063] Preferably the system **200** is used in a method of increasing the velocity of water flowing into a skimmer basket **160** that includes providing the system **200**, placing the basket **160** in the well **198** of a skimmer **100**, and flowing water and debris through the slot **221** of the first tube **210** and into the skimmer basket **160**. Optionally, the method further includes rotating the second tube **270** relative to the first tube **210**. Optionally, the method further includes the step of rotating the second tube **270** relative to the first tube **210** so that the second tube **270** partially covers the first tube slot **221**, and this rotation of the second tube **270** relative to the first tube **210** so that the second tube **270** partially covers the first tube slot **221** increases the velocity of water and debris entering the basket **160**.

[0064] In some embodiments, as shown in FIG. 35, the system **200** does not include a discrete first tube **210** but instead the housing **300** of the skimmer **100** acts as the first tube **210**. More particularly, as shown in FIG. 35, the system **200** includes a pool skimmer **100** that has a skimmer interior **137**, a skimmer exterior **138**, a skimmer opening **135** leading from the skimmer exterior **138** to the skimmer interior **137**, a skimmer basket **160** located in a well **198** of the skimmer interior **137**, and a water passageway **196** leading from the skimmer opening **135** to the

skimmer basket well **198**, the water passageway **196** having a height **139** and a width **140**, a second tube **270** located above the skimmer basket **160**, the second tube **270** comprising a top **271**, a bottom **274** comprising an opening **273**, a second tube height **275** extending from the bottom **274** to the top **271**, an interior **281**, an exterior **282**, and a second tube slot **283** configured to feed water from the second tube exterior **282** to the second tube interior **281** and the basket interior **167**, the second tube slot **283** located between the top **271** and the bottom **274** of the second tube **270**, the second tube slot **283** having a width **285** perpendicular to the second tube height **275** and a height **284** parallel to the second tube height **275**, the second tube **270** adjacent to the water passageway **196**, the second tube **270** configured to rotate relative to the water passageway **196** and at least partially cover the water passageway **196**. Optionally, the skimmer **100** further includes a weir **170**.

[0065] FIG. 36 shows a variation of the system of FIG. 35. In FIG. 36, the skimmer **100** is attached to the pool wall **120** via an arm **320**, and a pipe **180** feeds water that is filtered by the skimmer basket **160** to the pump **190**. In such an embodiment, the water passageway **196** and the skimmer opening **135** are the same – meaning that there is there is no channel between the basket well **198** and skimmer opening **135**. Skimmers **100** attached to the pool sidewall **120** are known in the art and include the INTEX Deluxe Wall Mount Swimming Pool Surface Skimmer. However, it is believed that previously known wall-mounted skimmers lack a slot **135** to increase the velocity of water entering the basket **160** as well as a door (in this case second tube **270**) which can be used to partially cover the slot **135** to further increase the flow of water entering basket **160**.

[0066] Terms of degree such as "substantially", "about" and "approximately" as used herein mean a reasonable amount of deviation of the modified term such that the end result is not significantly changed. For example, these terms can be construed as including a deviation of at least $\pm 5\%$ of the modified term if this
5 deviation would not negate the meaning of the word it modifies.

[0067] Having now described the invention in accordance with the requirements of the patent statutes, those skilled in the art will understand how to make changes and modifications to the disclosed embodiments to meet their specific requirements or conditions. Changes and modifications may be made without
10 departing from the scope and spirit of the invention, as defined and limited solely by the following claims.

CLAIMS

What is claimed is:

1. A system for improving the operation of a pool skimmer, the system
5 comprising:

a skimmer basket, the skimmer basket configured to be placed in a pool
skimmer and comprising a basket interior, a basket exterior, a floor, a top, a height
extending from the floor to the top, a sidewall extending upwardly from the floor,
and a plurality of apertures located in at least one of the basket sidewall and the
10 floor, wherein the basket floor and the basket sidewall separate the basket interior
from the basket exterior;

a first tube attached to the skimmer basket, the first tube comprising a top, a
bottom comprising an opening, a first tube height extending from the bottom to the
top, an interior, an exterior comprising a first flange extending from the first tube
15 towards the basket sidewall, and a first tube slot configured to feed water from the
first tube exterior to the first tube interior and the basket interior, the first tube slot
located between the top and the bottom of the first tube, the first tube slot having a
width perpendicular to the first tube height and a height parallel to the first tube
height; and

20 a second tube adjacent to the first tube, the second tube configured to rotate
relative to the first tube and at least partially cover the first tube slot, the second
tube comprising a top, a bottom, a second tube height extending from the bottom to
the top, and a second tube slot located between the top and the bottom of the second

tube, the second tube slot having a width perpendicular to the second tube height and a height parallel to the second tube height.

2. The system of claim 1, wherein the tops of the first and second tubes each comprise openings.

5 3. The system of claim 1, wherein the first tube is located inside the second tube interior.

4. The system of claim 1 further comprising a pool, the pool comprising a sidewall, the pool sidewall comprising a pool skimmer, the pool skimmer comprising a skimmer interior and a skimmer opening leading from the pool to the skimmer
10 interior and further wherein the basket is located in the skimmer interior.

5. The system of claim 4, wherein a widthwise center of the first tube slot is offset from a widthwise center of the skimmer opening by at least about 30 degrees.

6. The system of claim 1, wherein the first flange and the skimmer basket are permanently attached to each other.

15 7. The system of claim 1, wherein the first flange and the skimmer basket are mechanically attached to each other.

8. The skimmer basket of claim 1, wherein the first flange is pivotally attached to the skimmer basket by a hinge.

9. The system of claim 1, wherein the first flange is removably attached to the
20 skimmer basket by a fastener.

10. The system of claim 9, wherein the fastener is at least about 3 inches in length and comprises threads.

11. The system of claim 9, wherein the first flange comprises a flange fastener aperture and the fastener passes through the flange fastener aperture.

12. The system of claim 11, wherein the first fastener aperture substantially extends to an outer edge of the first flange.
13. The system of claim 9, wherein the fastener passes through an aperture in the basket.
- 5 14. The system of claim 1, wherein the first flange and the basket comprise mating threads for removably attaching the first flange to the basket.
15. The system of claim 1, wherein the width of the first tube slot is at least about 1 inch, the width of the second tube slot is at least about 1 inch, the height of the first tube slot is at least about 4 inches and the height of the second tube slot is
- 10 at least about 4 inches.
16. The system of claim 1, wherein the first tube and the second tube are generally cylindrical.
17. The system of claim 1, wherein the first tube height is greater than the second tube height, wherein the second tube is located above the first flange and
- 15 further wherein the first tube comprises an upper flange extending about a perimeter of the first tube, the upper flange located above the first flange and the second tube.
18. The system of claim 1, wherein the first flange comprises a groove adjacent to the first tube and extending about a perimeter of the first tube, further wherein the
- 20 bottom of the second tube is located in the groove.
19. The system of claim 1, wherein the first tube slot comprises a top and a bottom, and the bottom of the first tube slot is adjacent to a top of the first flange.

20. The system of claim 1, wherein the system further comprises a washer attached to the first flange, the washer comprising a washer opening in fluid communication with the first tube bottom aperture.

21. The system of claim 20, wherein the washer comprises a washer fastener
5 aperture configured to receive a fastener and further wherein the washer extends beyond a perimeter of the first flange.

22. A method of increasing the velocity of water flowing into a skimmer basket, the method comprising the steps of:

providing the basket system of claim 1; and
10 flowing water through the slot of the first tube and into the skimmer basket interior.

23. The method of claim 22 further comprising the step of rotating the second tube relative to the first tube.

24. The method of claim 22 further comprising the step of rotating the second
15 tube relative to the first tube so that the second tube partially covers the first tube slot, and further wherein rotation of the second tube relative to the first tube so that the second tube partially covers the first tube slot increases the velocity of water entering the basket interior.

25. A kit for increasing the velocity of water flowing into a skimmer basket, the
20 kit comprising:

a first tube, the first tube comprising a top, a bottom comprising an opening, a height extending from the bottom to the top, an interior, an exterior, an inner diameter perpendicular to said height, an outer diameter perpendicular to said height, a first tube slot having a width of at least about 1 inch and a height of at

least about 4 inches, the first tube slot width parallel to the inner and outer diameters of the first tube, the first tube slot height perpendicular to the inner and outer diameters of the first tube, the first tube exterior comprising a first flange extending from the first tube, the first flange configured to attach to a skimmer
5 basket, at least one of the first tube and the first flange comprising a plurality of fastener apertures for attaching the first tube to a skimmer basket; and

a second tube, the second tube comprising a top, a bottom comprising a bottom opening, a height extending from the bottom to the top, an interior, an exterior, an inner diameter perpendicular to said height, an outer diameter
10 perpendicular to said height, and a second tube slot having a width of at least about 1 inch and a height of at least about 4 inches, the second tube slot width parallel to the inner and outer diameters of the second tube, the second tube slot height perpendicular to the inner and outer diameters of the second tube.

26. The kit of claim 25 wherein the inner diameter of the second tube is between
15 about 100% and about 120% of the size of the outer diameter of the first tube.

27. The kit of claim 25 wherein the first flange comprises a groove adjacent to the first tube and extending about an outer circumference of the first tube.

28. The kit of claim 25 further comprising an upper flange extending about an outer circumference of the first tube.

20 29. The kit of claim 25, wherein the first tube is located between the fastener apertures.

30. A pool skimmer system comprising:

a pool skimmer, the pool skimmer comprising a skimmer interior, a skimmer exterior, and a skimmer opening leading from the skimmer exterior to the skimmer interior;

5 a skimmer basket disposed in the skimmer interior, the skimmer basket comprising a basket interior, a basket exterior, a floor, a top, a height extending from the floor to the top, a sidewall extending upwardly from the floor, and at least one aperture located in at least one of the basket sidewall and the floor, wherein the basket floor and the basket sidewall separate the basket interior from the basket exterior;

10 a first tube located above the skimmer basket, the first tube comprising a top, a bottom comprising an opening, a first tube height extending from the bottom to the top, an interior, an exterior, and a first tube slot configured to feed water from the first tube exterior to the first tube interior and the basket interior, the first tube slot located between the top and the bottom of the first tube, the first tube slot having a width perpendicular to the first tube height and a height parallel to the
15 first tube height; and

a door adjacent to the first tube, the door configured to move horizontally relative to the first tube and at least partially cover the first tube slot.

31. A kit for increasing the velocity of water flowing into a skimmer basket, the
20 kit comprising:

a first tube, the first tube comprising a top, a bottom comprising an opening, a height extending from the bottom to the top, an interior, an exterior, a first tube slot having a width of at least about 1 inch and a height of at least about 4 inches, the first tube slot width perpendicular to the first tube height, the first tube slot

height parallel to the first tube height, the first tube exterior comprising a first flange extending from the first tube, the first flange configured to attach to a skimmer basket, the first flange comprising a plurality of fastener apertures for attaching the first tube to a skimmer basket, the first flange circular in shape and
5 comprising a circumference; and

a circular washer, the washer comprising a washer opening and a plurality of washer fastener apertures configured to receive a plurality of fasteners, the washer circular in shape and having a larger circumference than the circumference of the first flange,

10 wherein the first tube is located between the plurality of flange fastener apertures and

further wherein the washer opening is located between the plurality of washer fastener apertures.

32. The kit of claim 31, wherein the washer has a diameter of between about 6
15 inches and about 14 inches.

33. The kit of claim 31 further comprising a plurality of rods, said rods comprising threads, said rods having a length of from about 3 inches to about 12 inches, said rods configured to be received in said washer fastener apertures and said flange fastener apertures.

20 34. The kit of claim 31, wherein the washer opening is located in the center of the washer.

35. The kit of claim 31, wherein the washer opening has a width of from about 3 inches to about 6 inches.

36. A system for improving the operation of a pool skimmer, the system comprising:

a pool skimmer, the pool skimmer comprising a skimmer interior, a skimmer exterior, and a skimmer opening leading from the skimmer exterior to the skimmer interior;

5 a skimmer basket disposed in the skimmer interior, the skimmer basket configured to be placed in a pool skimmer and comprising a basket interior, a basket exterior, a floor, a top, a height extending from the floor to the top, a sidewall extending upwardly from the floor, and a plurality of apertures located in at least one of the basket sidewall and the floor, wherein the basket floor and the basket sidewall separate the basket interior from the basket exterior;

10 a first tube attached to the skimmer basket, the first tube comprising a top, a bottom comprising an opening, a first tube height extending from the bottom to the top, an interior, an exterior comprising a first flange extending from the first tube towards the basket sidewall, and a first tube slot configured to feed water from the first tube exterior to the first tube interior and the basket interior, the first tube slot located between the top and the bottom of the first tube, the first tube slot having a width perpendicular to the first tube height and a height parallel to the first tube height, the first tube slot having an average width of between about 1 inch and about 3.5 inches.

15 20 37. The kit of claim 36, wherein the first tube comprises a width perpendicular to said first tube height and further wherein the bottom of the first tube comprises no lip surrounding said opening.

38. The kit of claim 36, wherein said opening in the first tube has a width perpendicular to said first tube height and further wherein said width of said opening is from about 3 inches to about 4 inches.

39. A system for improving the operation of a pool skimmer, the system
5 comprising:

a pool skimmer, the pool skimmer comprising a skimmer interior, a skimmer exterior, a skimmer opening leading from the skimmer exterior to the skimmer interior, a skimmer basket well located in the skimmer interior, and a water passageway leading to the skimmer basket well, the water passageway having a
10 height and a width;

a skimmer basket disposed in the skimmer basket well, the skimmer basket comprising a basket interior, a basket exterior, a floor, a top, a height extending from the floor to the top, a sidewall extending upwardly from the floor, and at least one aperture located in at least one of the basket sidewall and the floor, wherein the
15 basket floor and the basket sidewall separate the basket interior from the basket exterior;

a tube located above the skimmer basket, the tube comprising a top, a bottom comprising an opening, a tube height extending from the bottom to the top, an interior, an exterior, and a tube slot configured to feed water from the tube exterior
20 to the tube interior and the basket interior, the tube slot located between the top and the bottom of the tube, the tube slot having a width perpendicular to the tube height and a height parallel to the tube height, the tube adjacent to the water passageway, the tube configured to rotate relative to the water passageway and at least partially cover the water passageway.

40. The system of claim 39 wherein the tube is attached to the skimmer basket.
41. The system of claim 39, wherein the system further comprises a pump in fluid communication with the skimmer basket, a pool and a pool sidewall.
42. The system of claim 39, wherein the water passageway has a width of at least
5 about 2 inches and a height of at least about 4 inches.
43. The system of claim 39 wherein the tube is generally cylindrical.
44. The system of claim 39 wherein the system further comprises a weir located in the water passageway, the weir moveable between a vertical position in which the weir is parallel to the water passageway height and a horizontal position in
10 which the weir is parallel to the water passageway width.

1/30

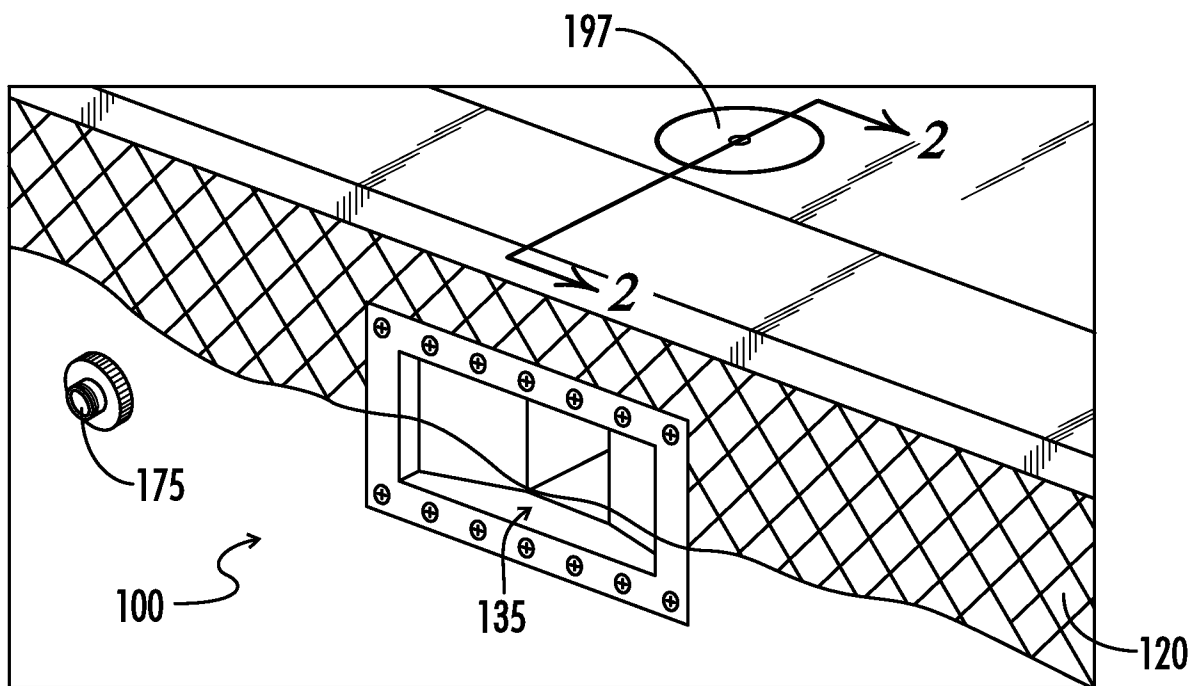

FIG. 1
(PRIOR ART)

2/30

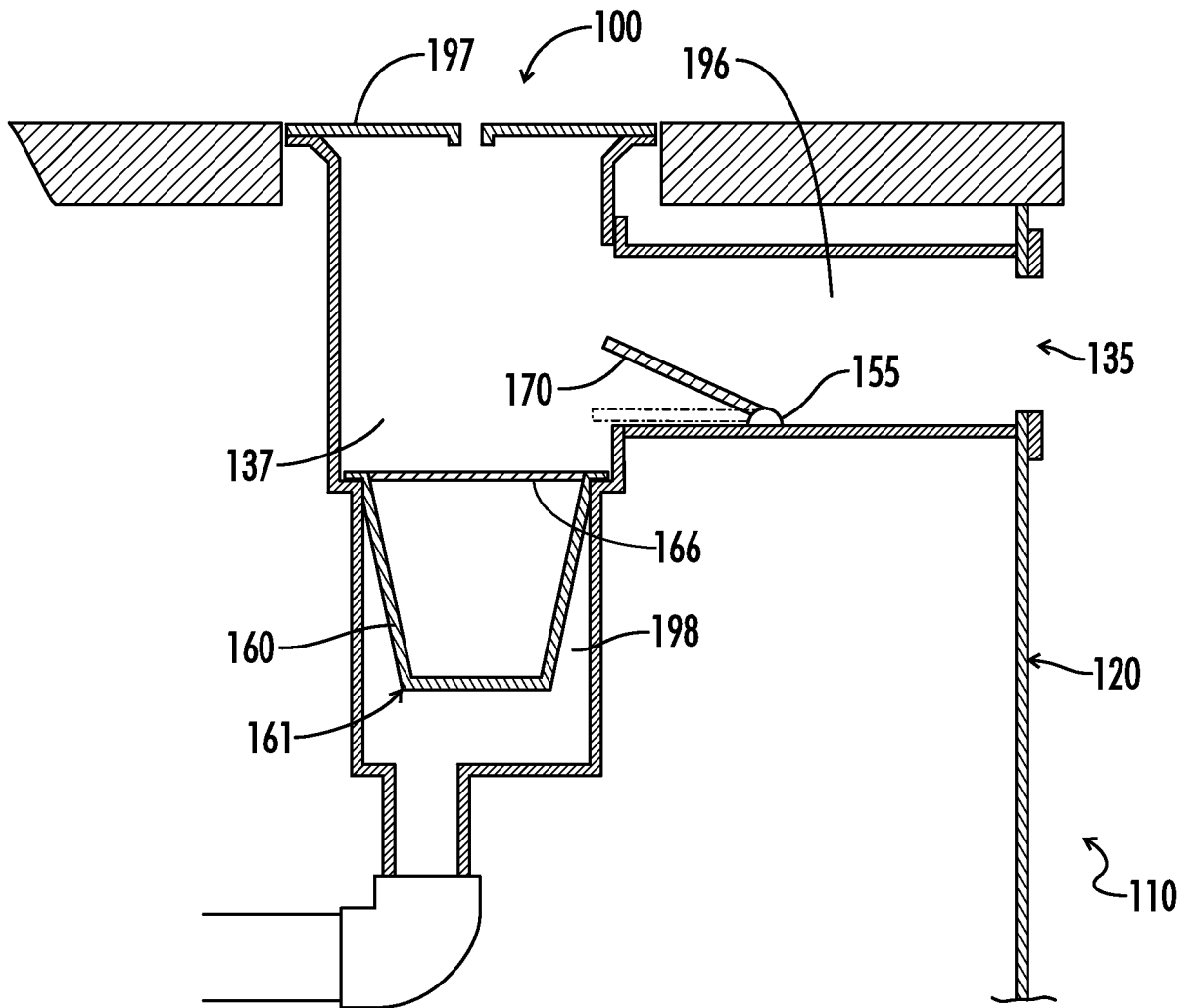

FIG. 2
(PRIOR ART)

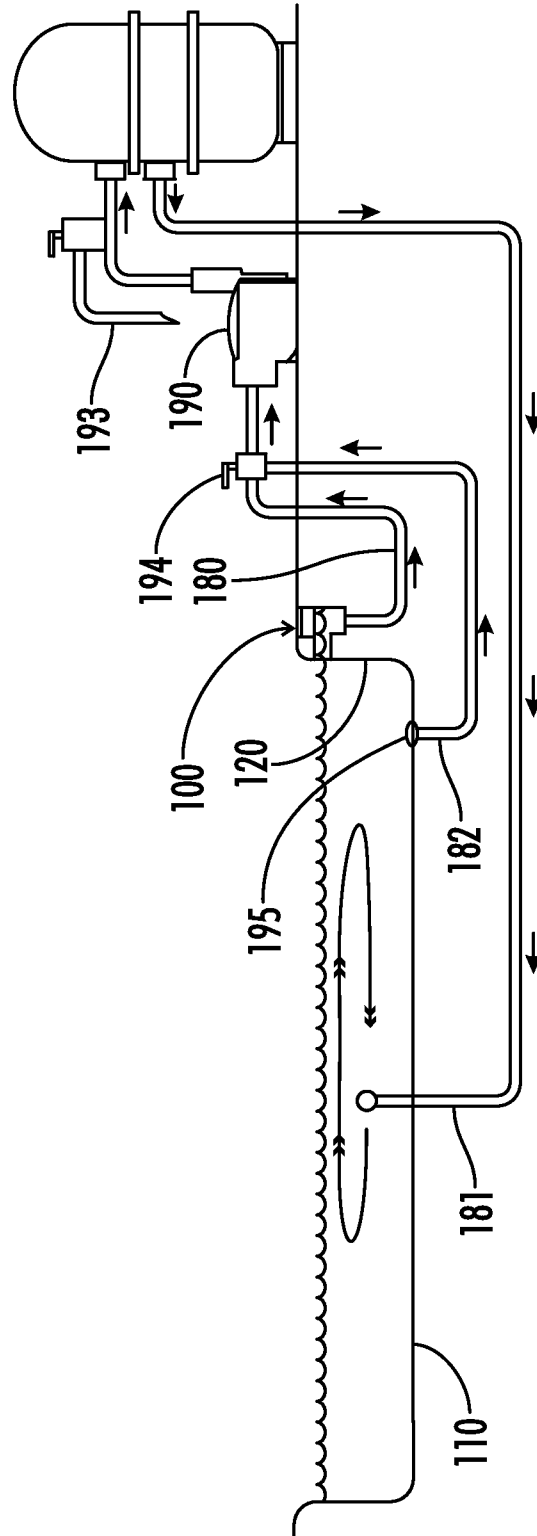

FIG. 3
(PRIOR ART)

4/30

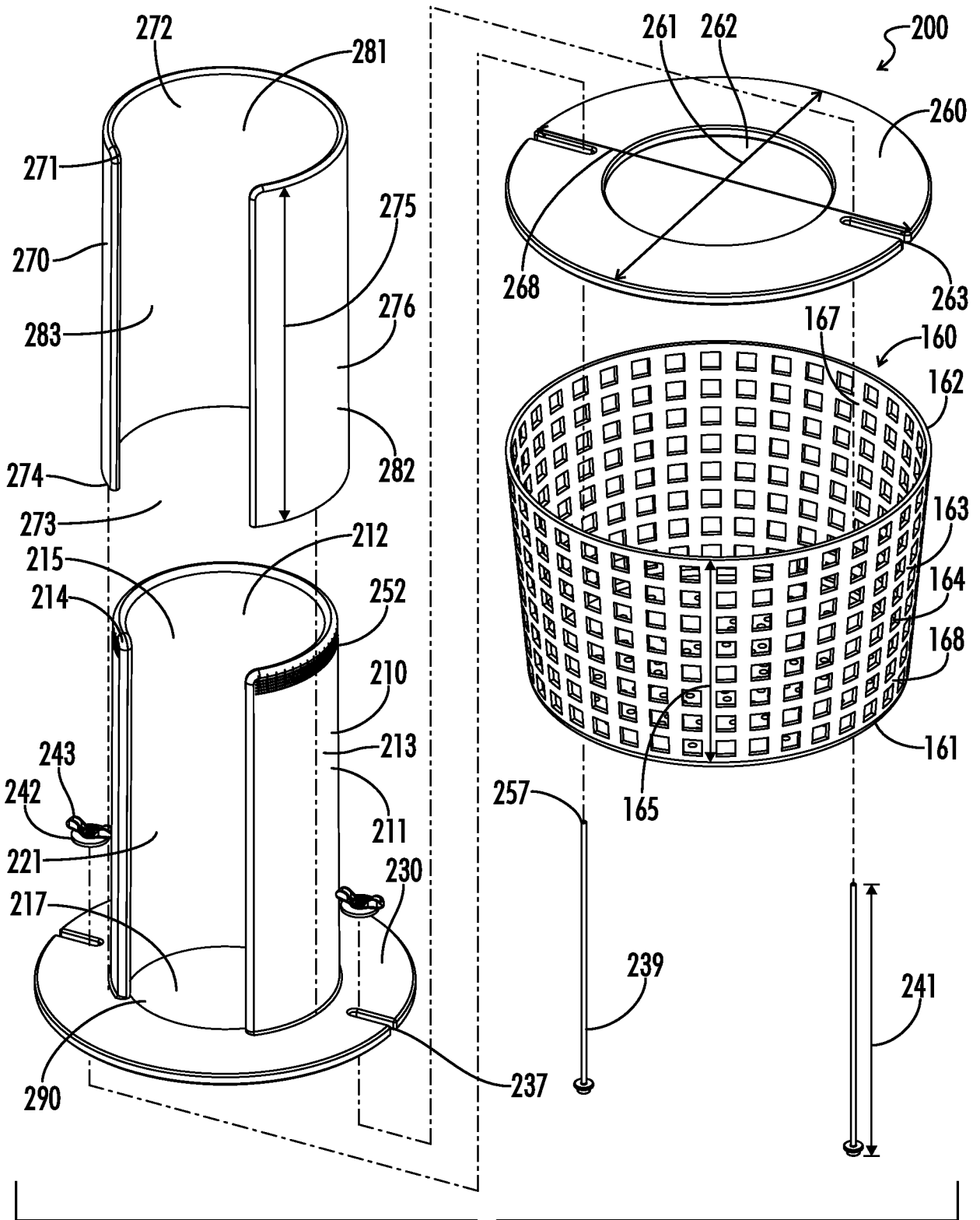

FIG. 4

5/30

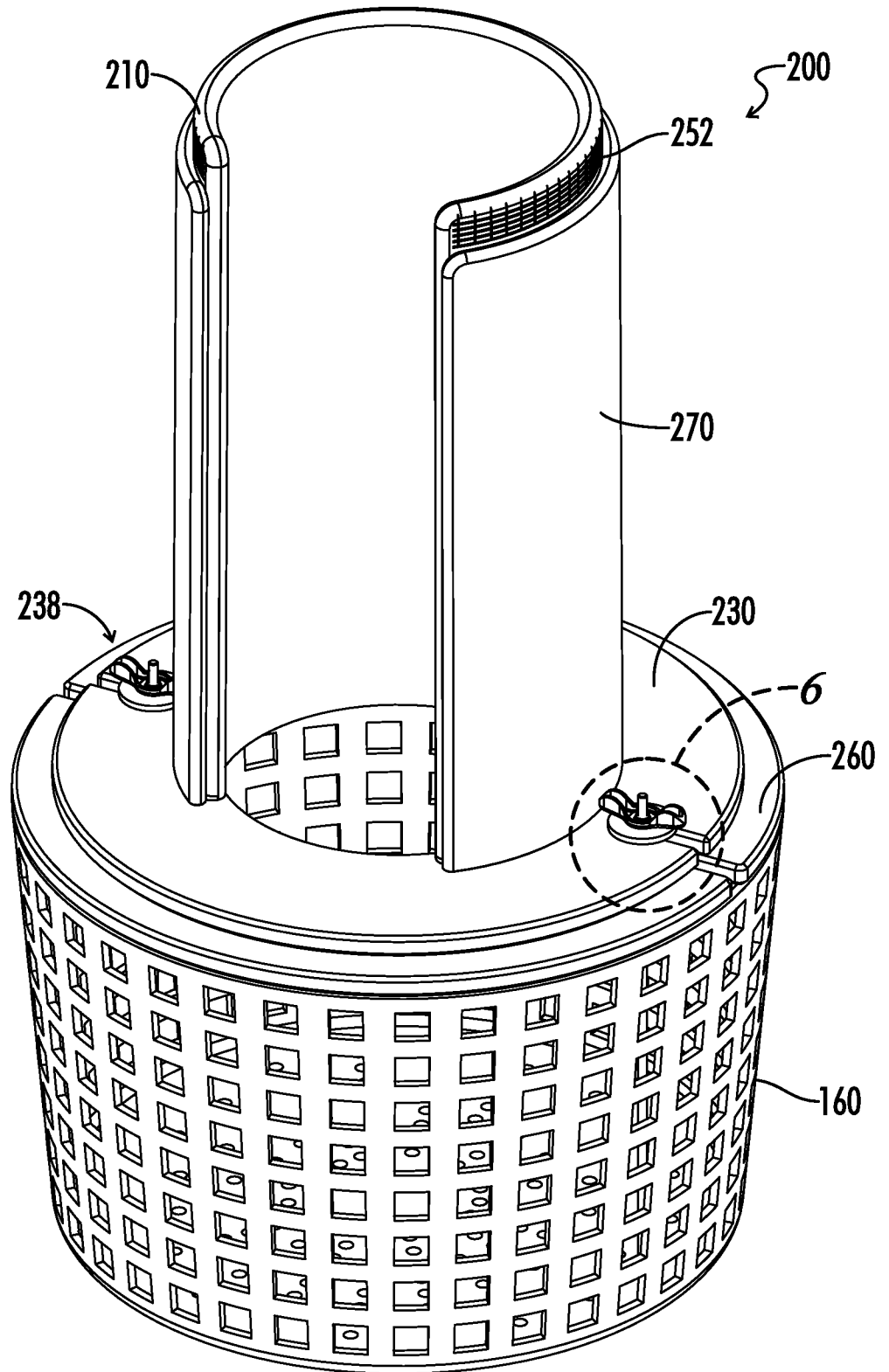

FIG. 5

6/30

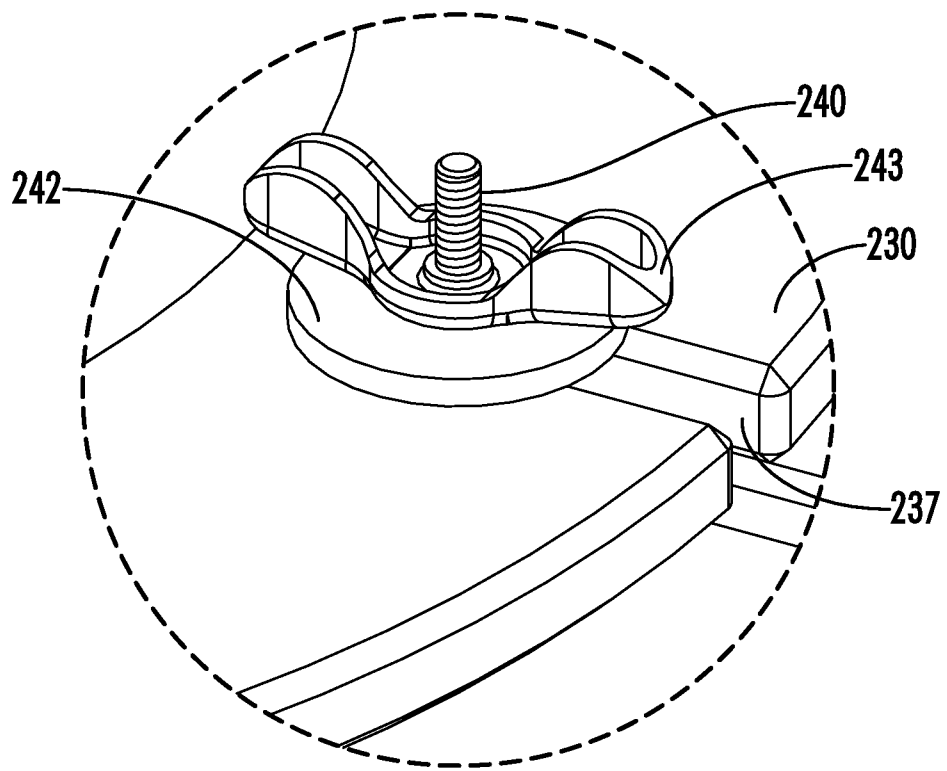

FIG. 6

7/30

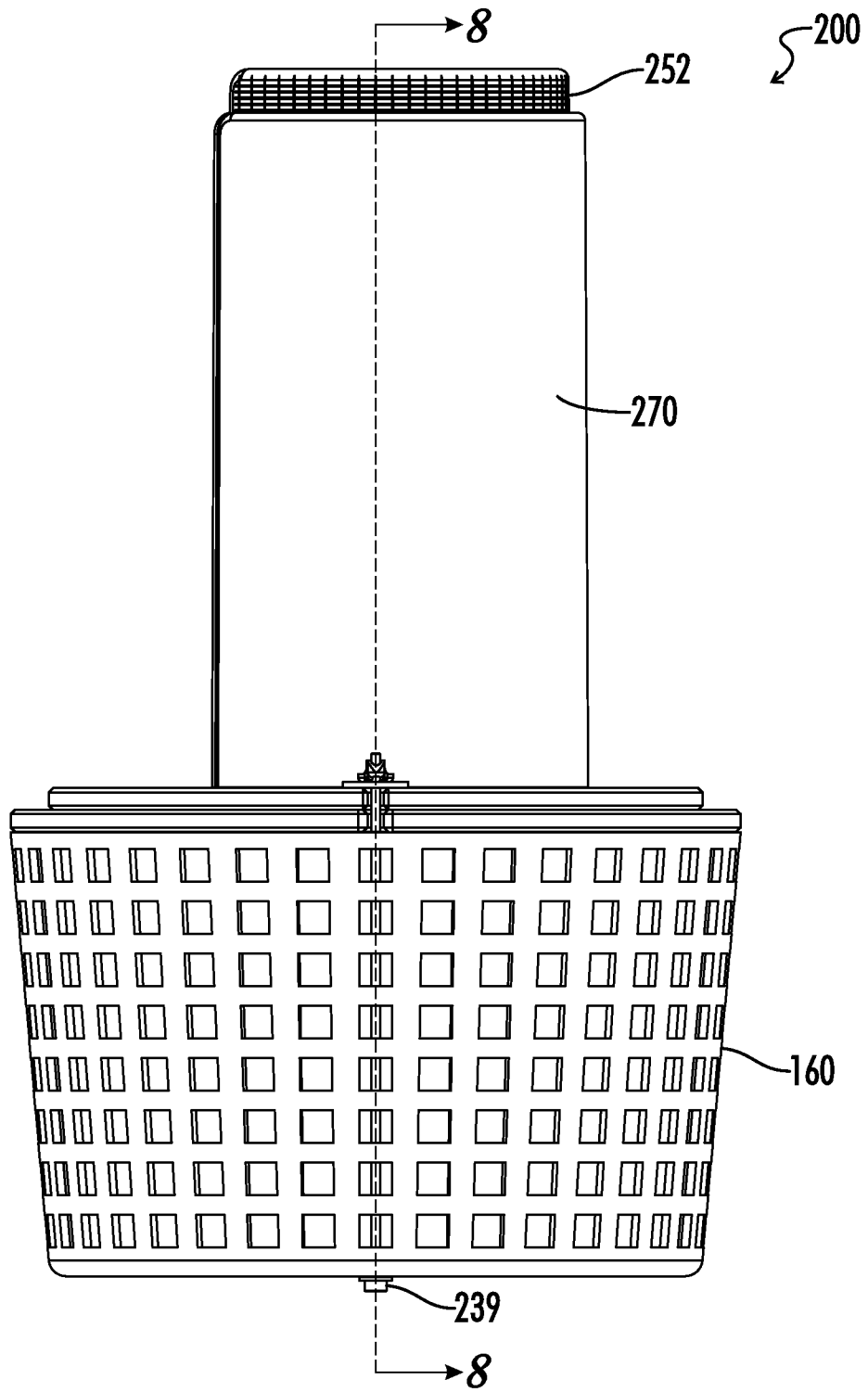

FIG. 7

8/30

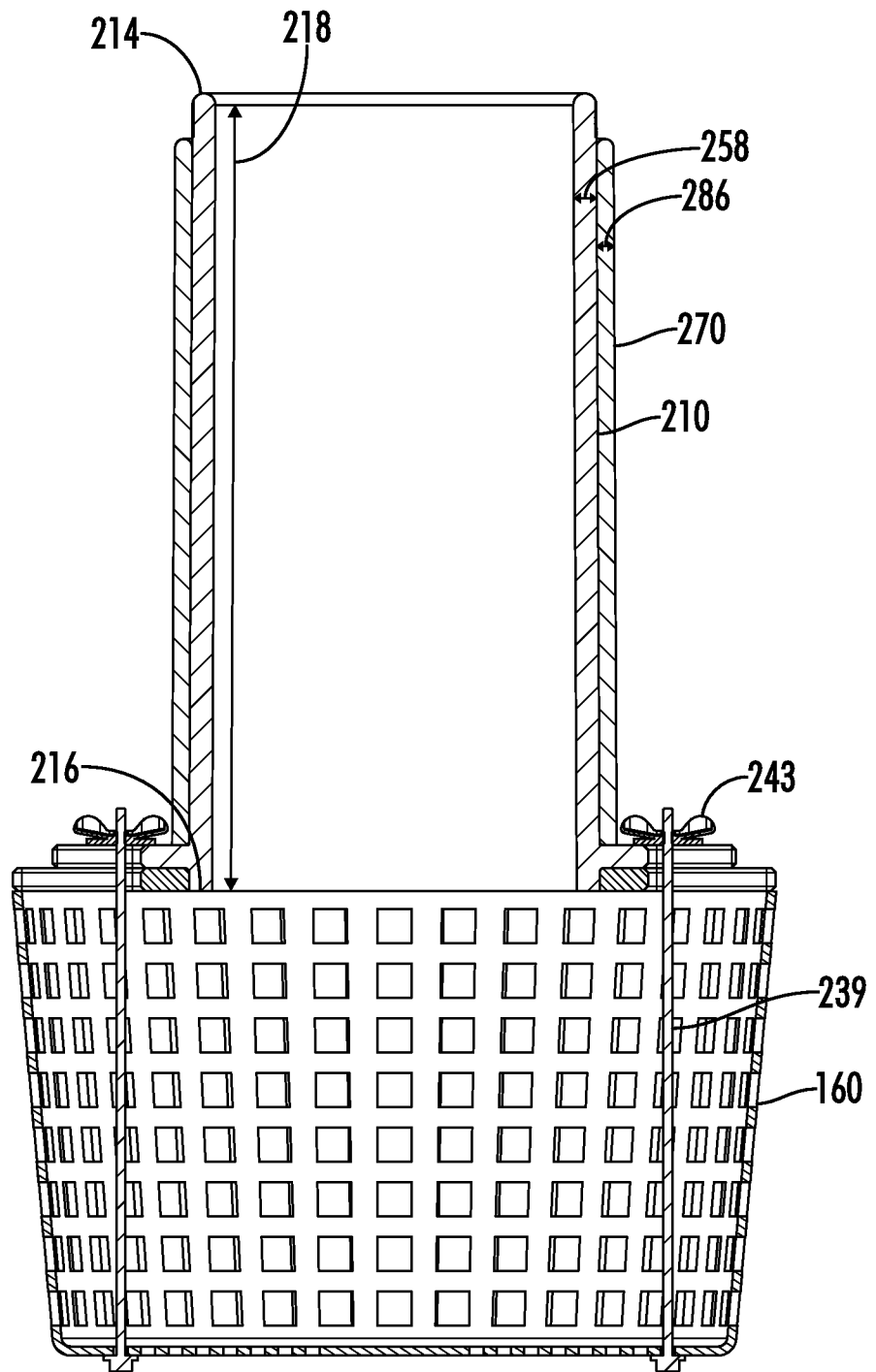

FIG. 8

9/30

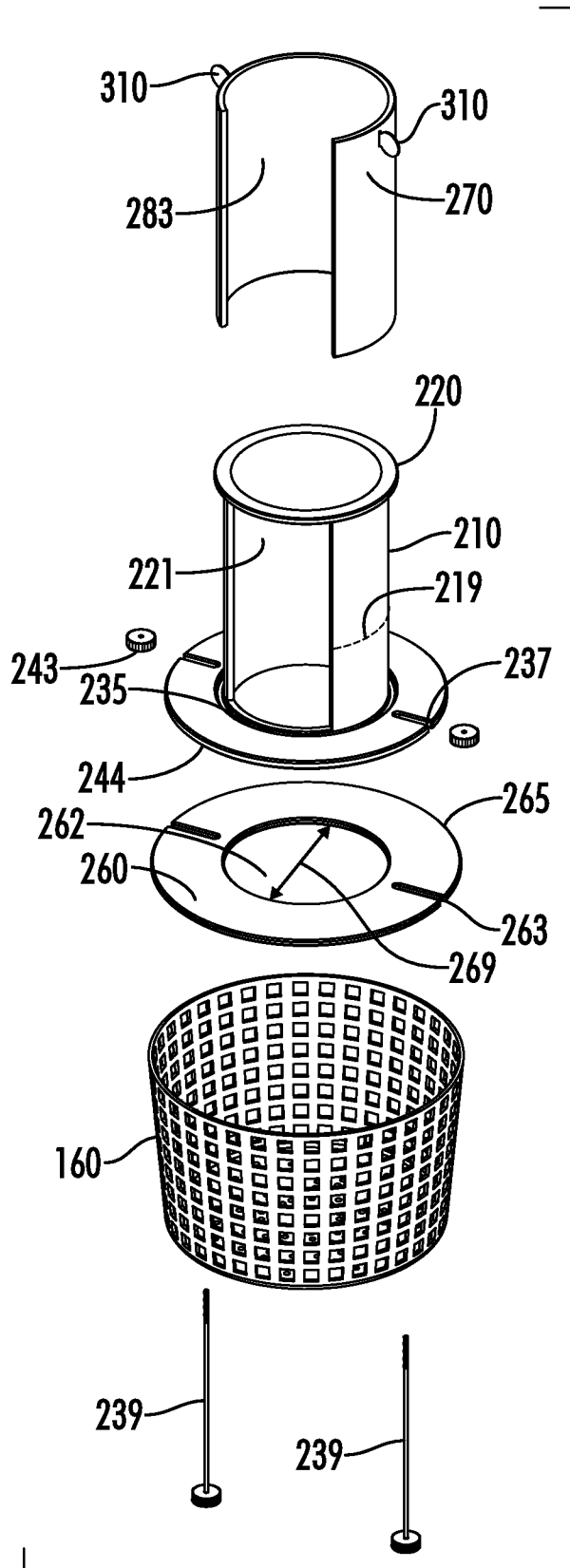

FIG. 9

10/30

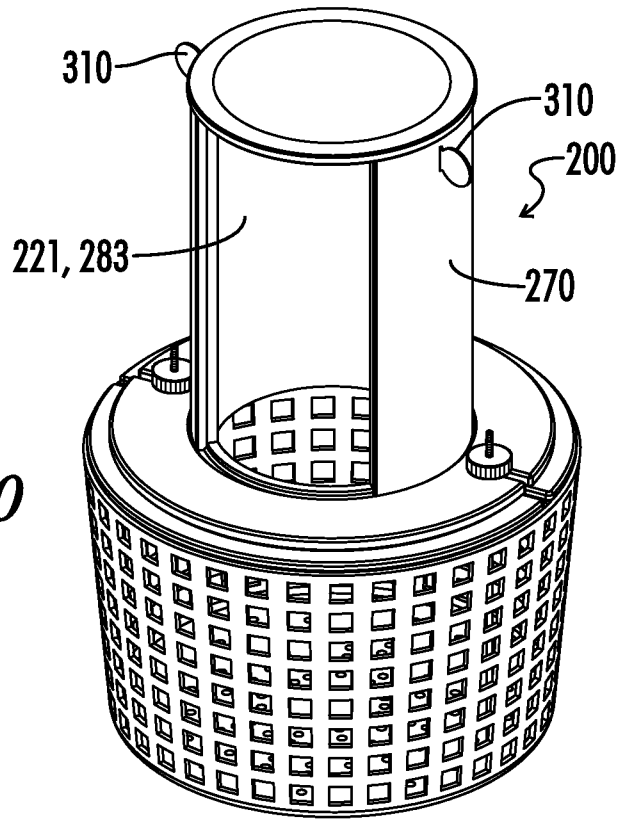

FIG. 10

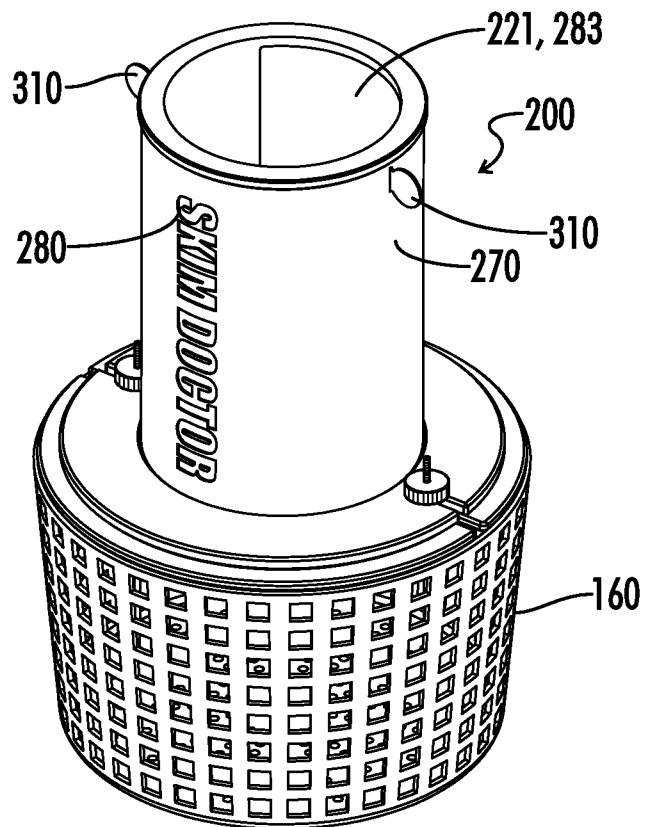

FIG. 11

11/30

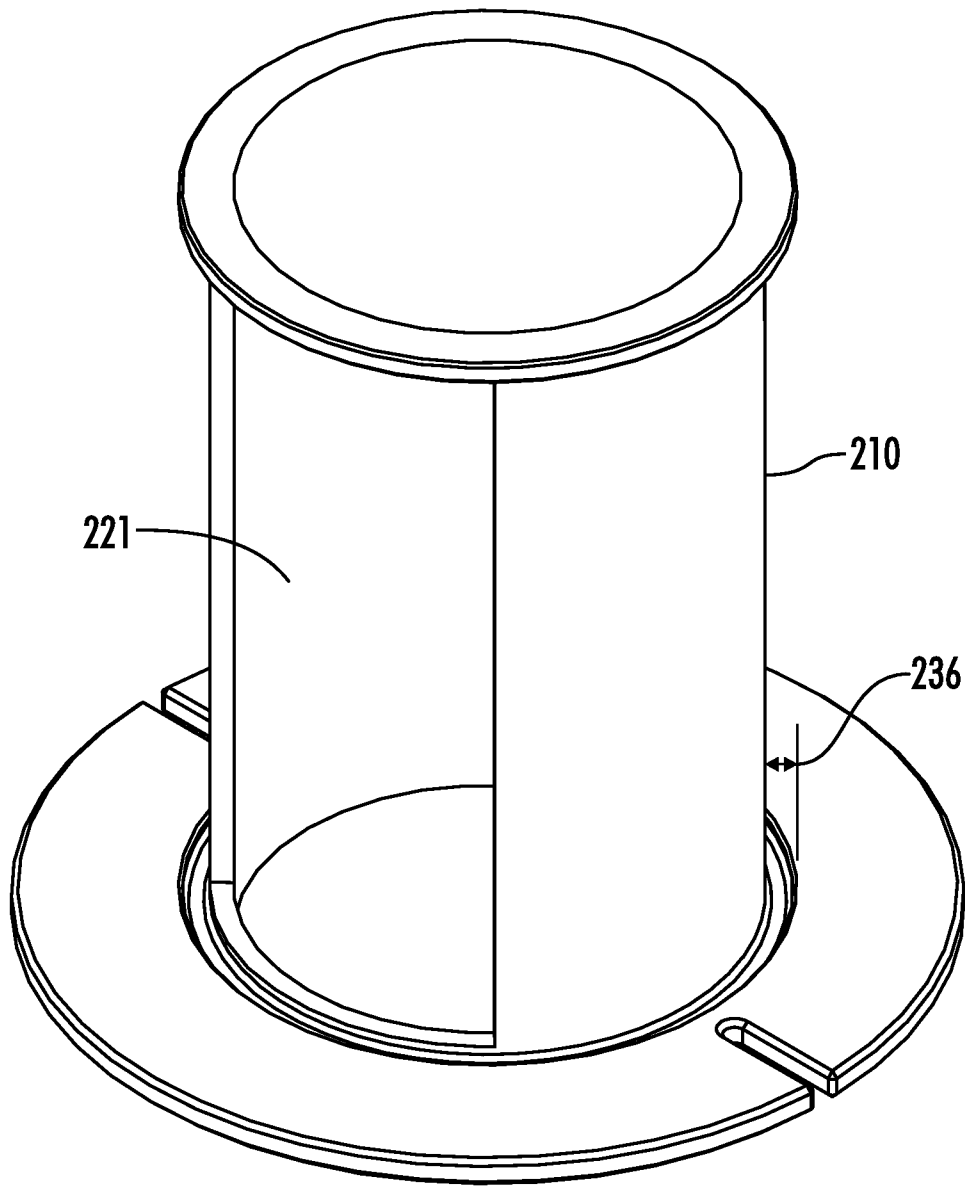

FIG. 12A

12/30

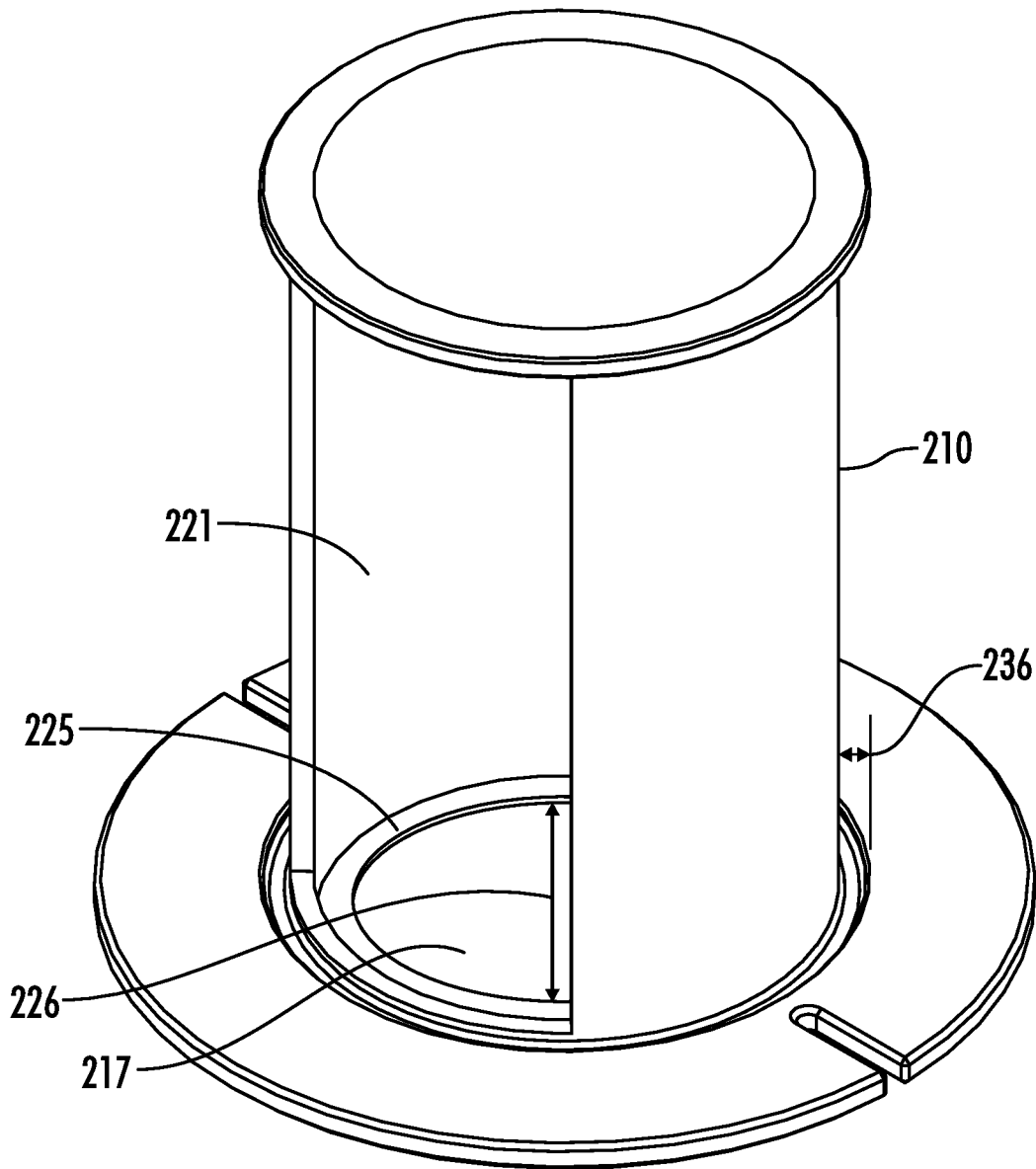

FIG. 12B

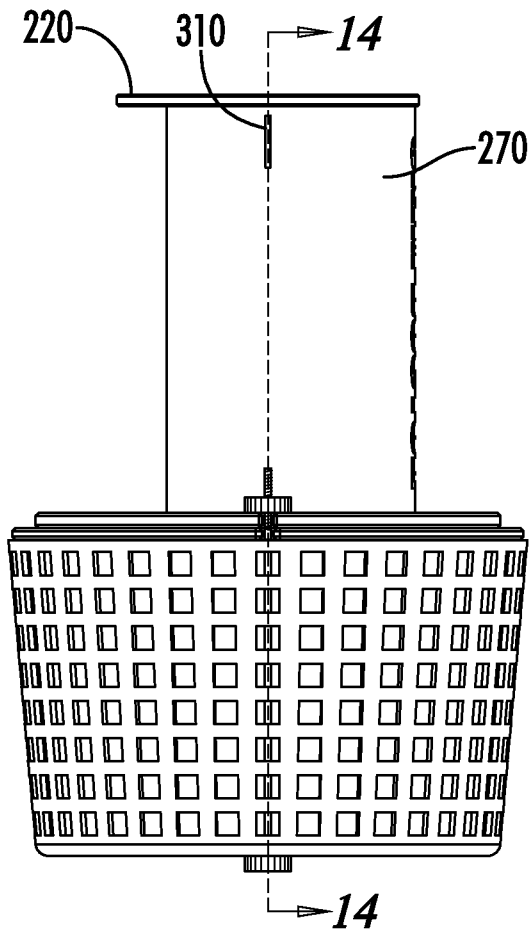

FIG. 13

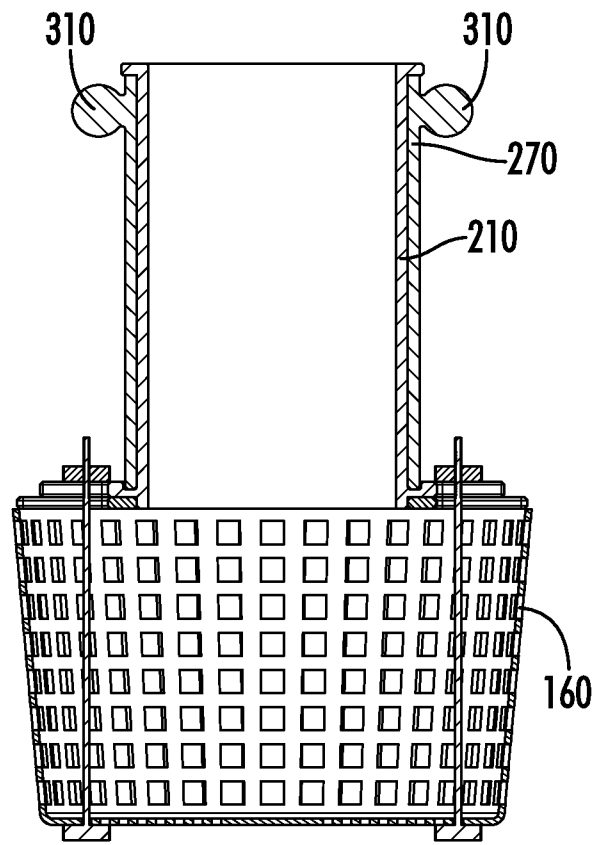

FIG. 14

14/30

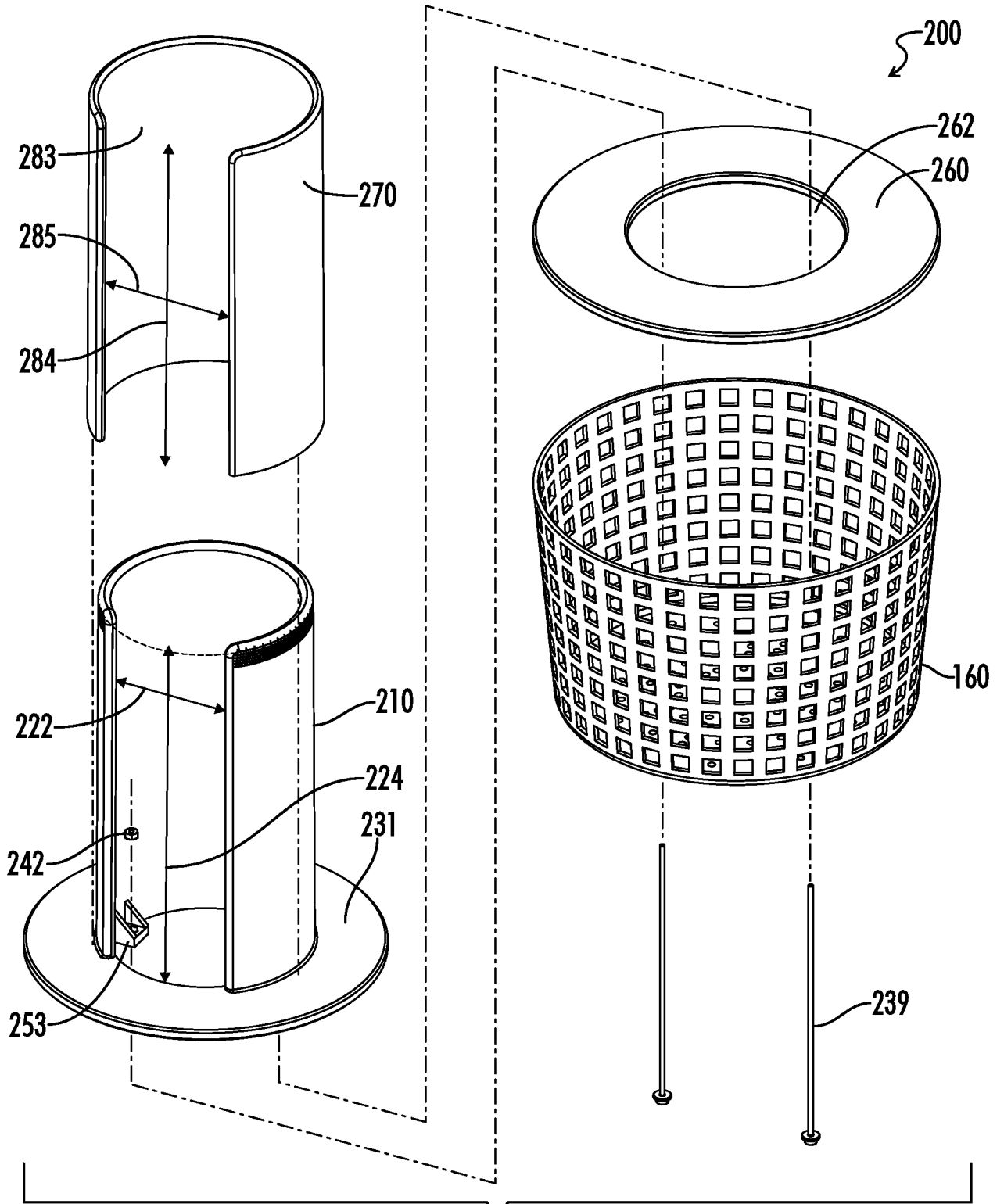

FIG. 15

15/30

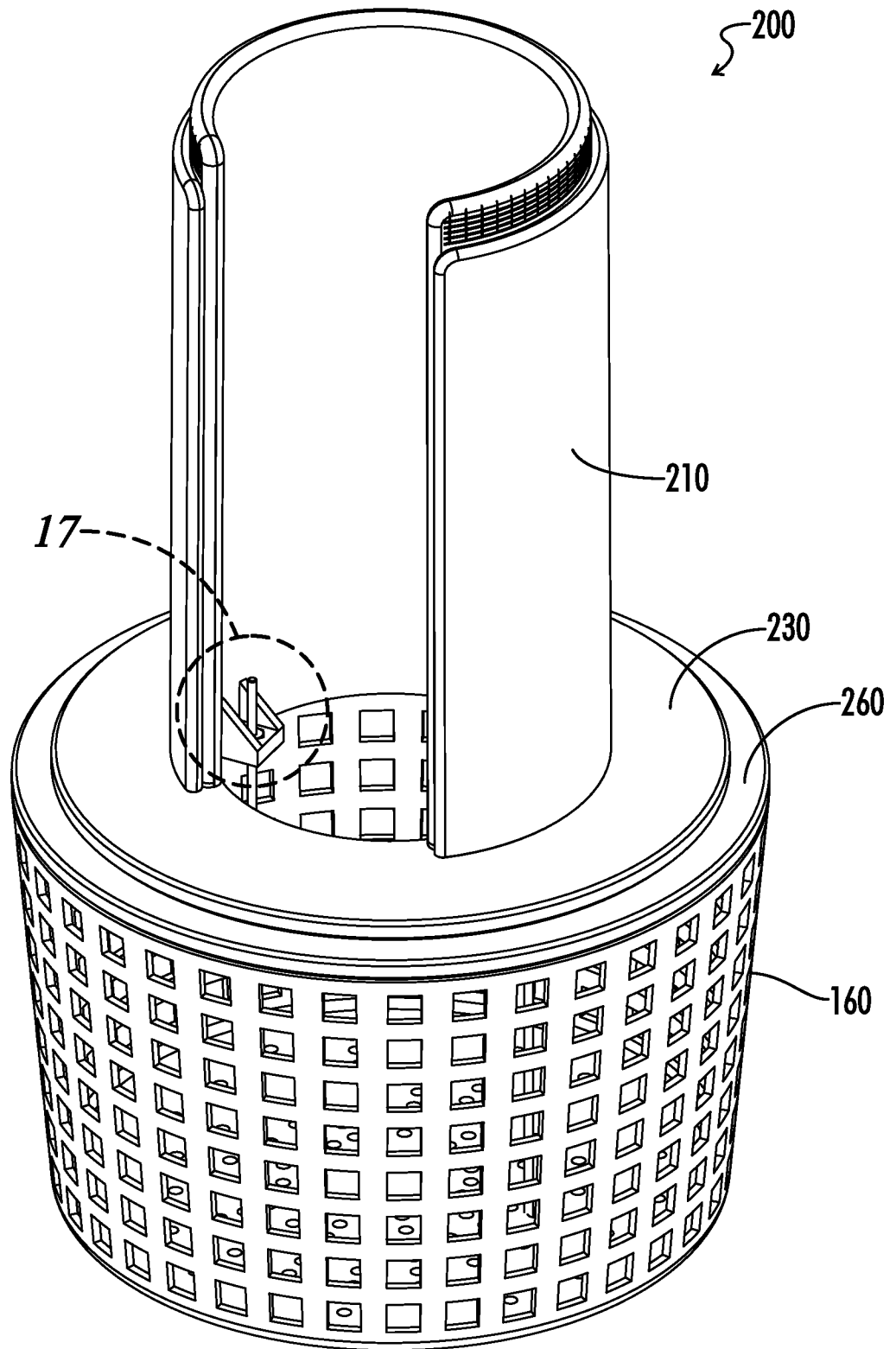

FIG. 16

16/30

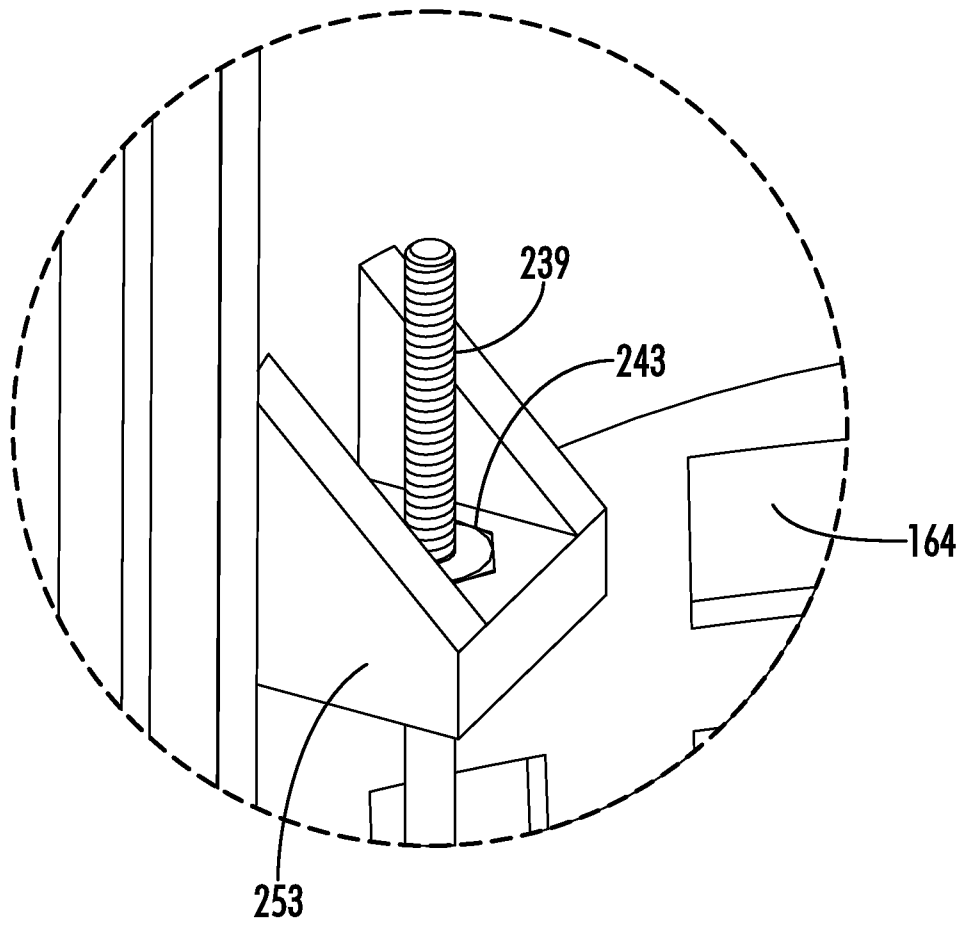

FIG. 17

17/30

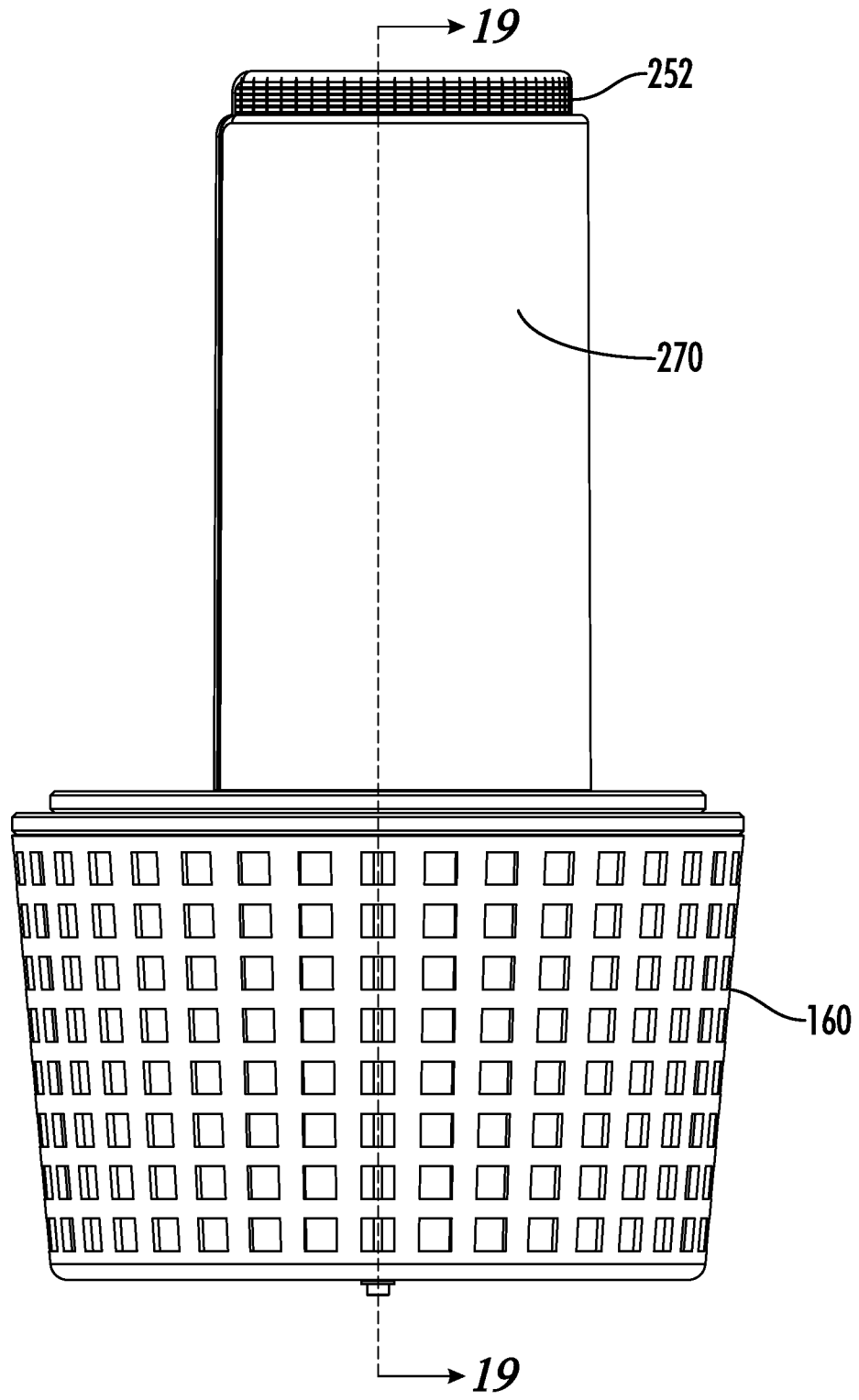

FIG. 18

18/30

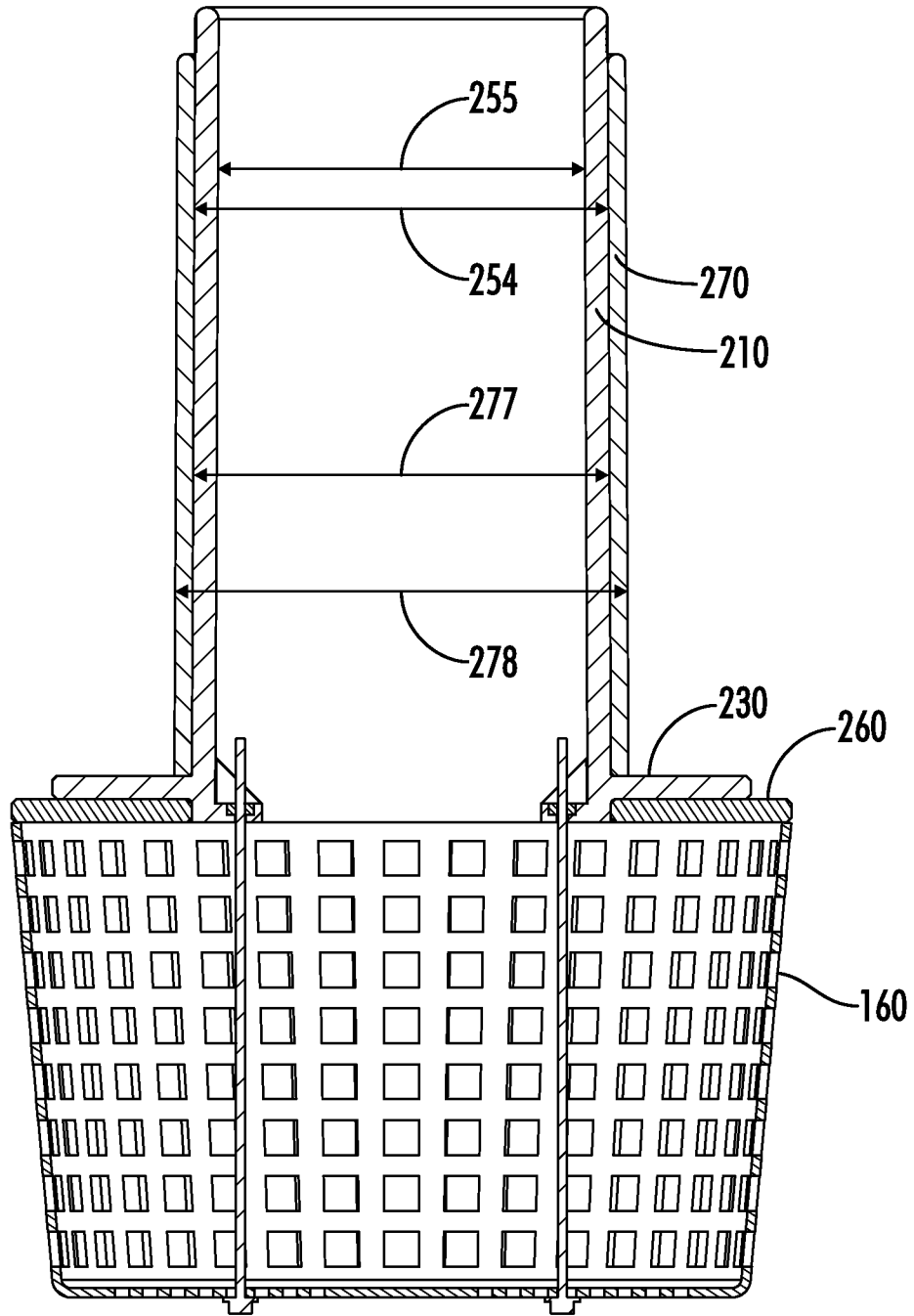

FIG. 19

19/30

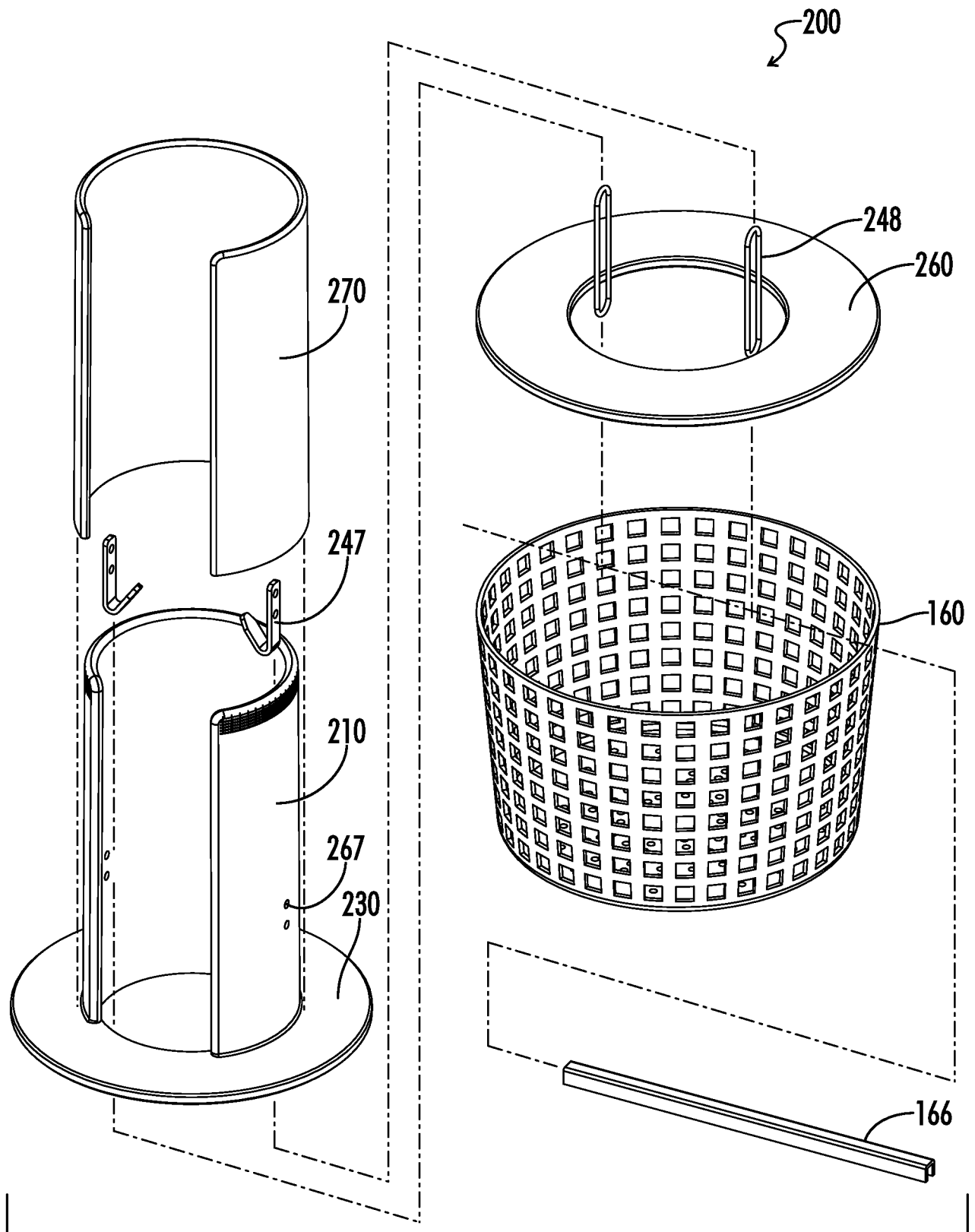

FIG. 20

20/30

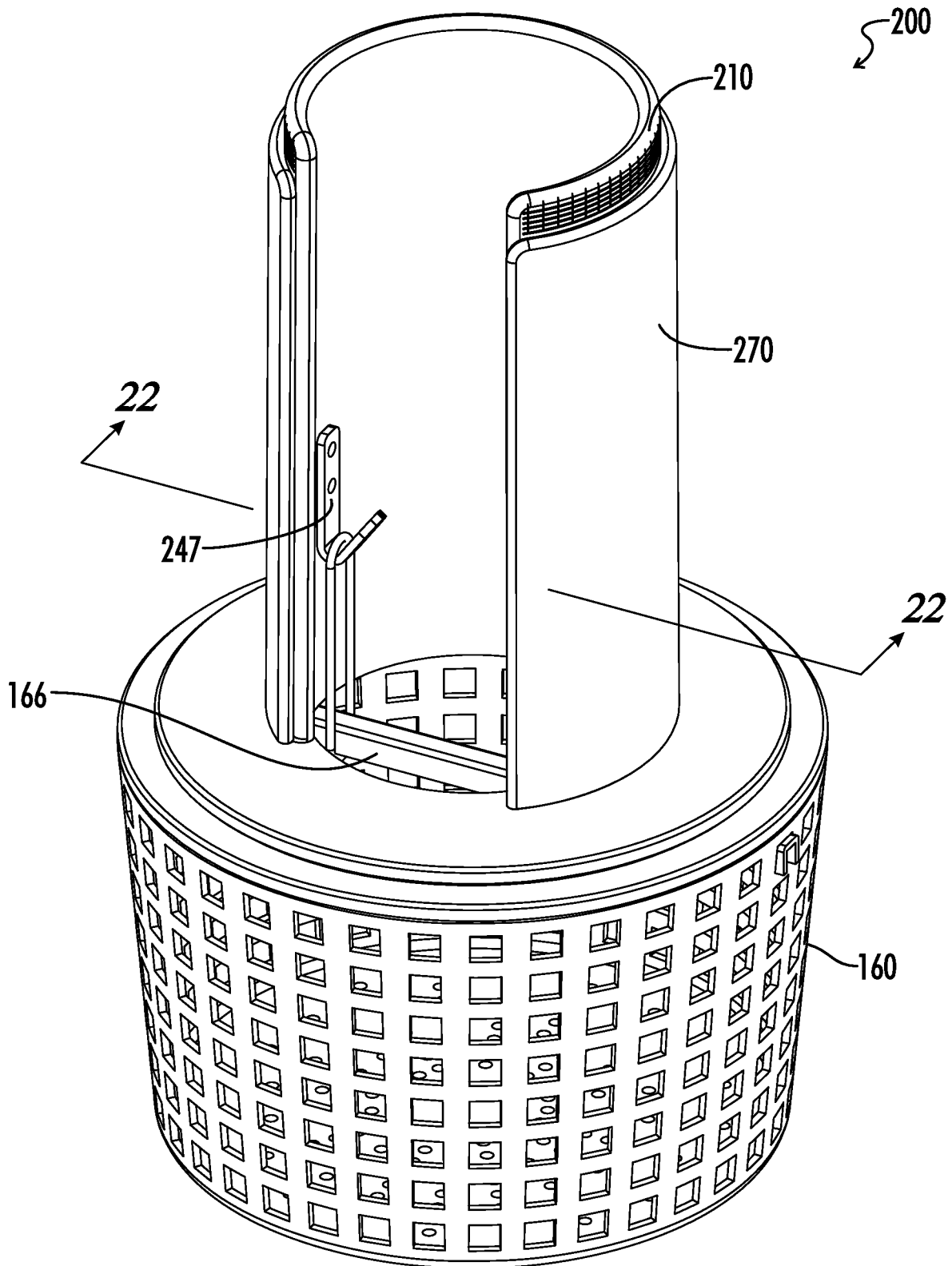

FIG. 21

21/30

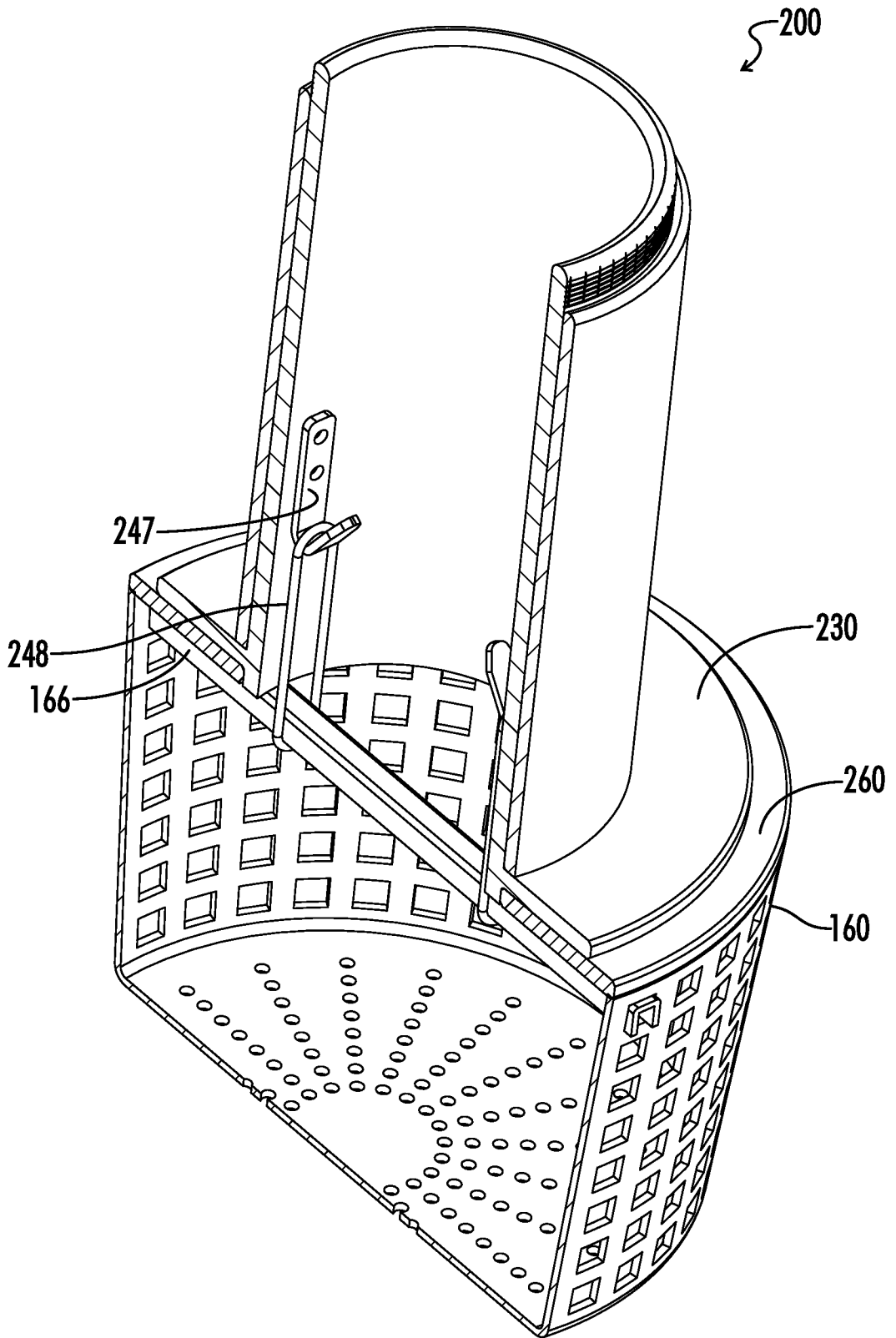

FIG. 22

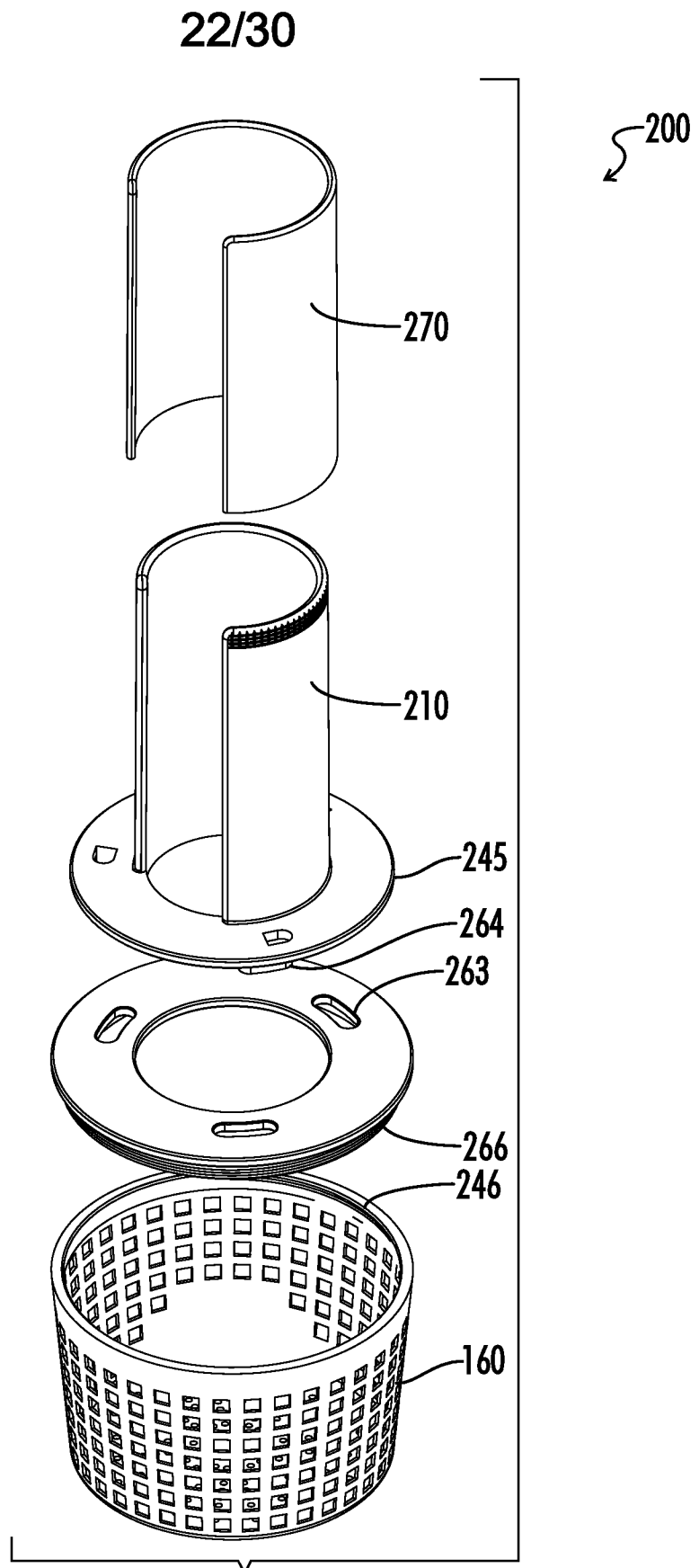

FIG. 23

23/30

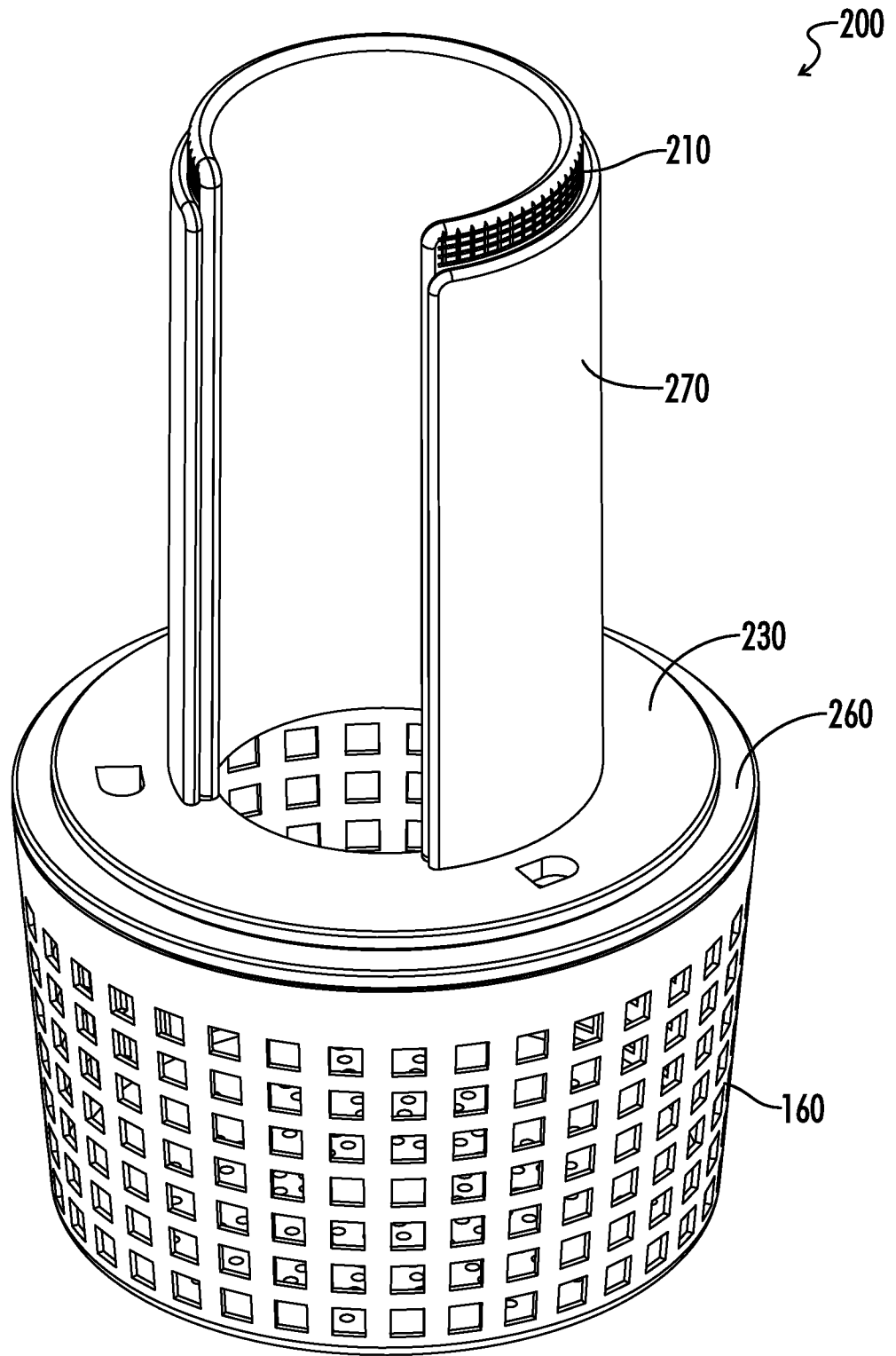

FIG. 24

24/30

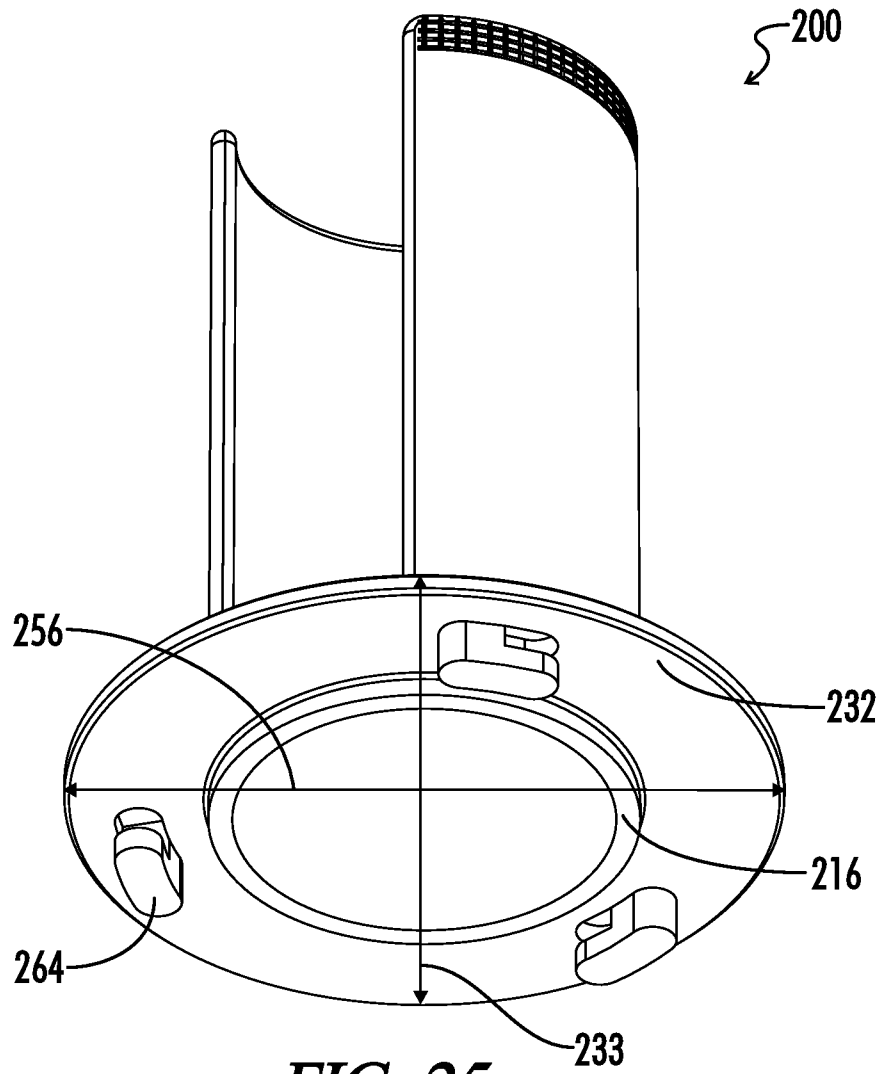

FIG. 25

25/30

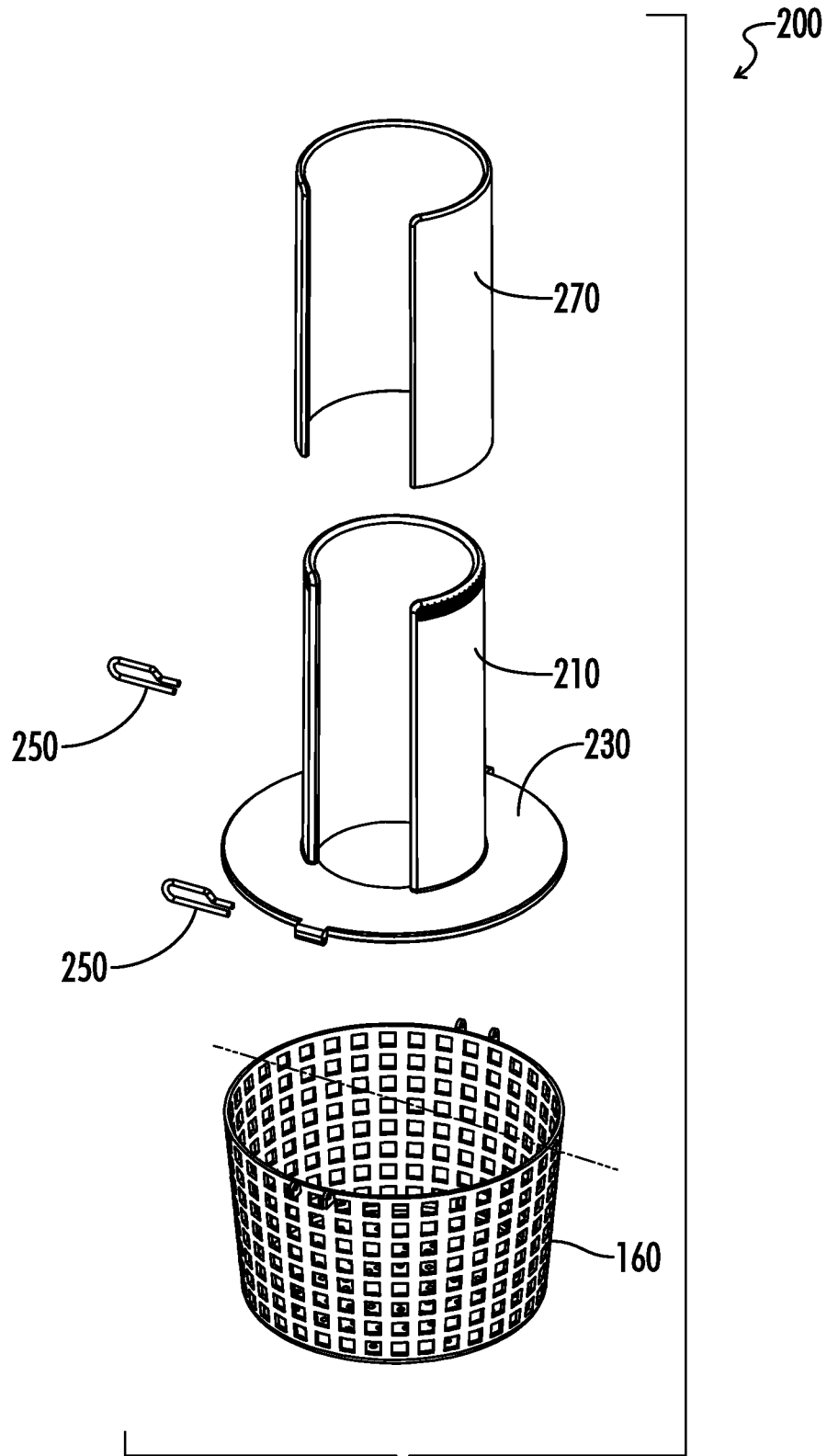

FIG. 26

26/30

FIG. 27

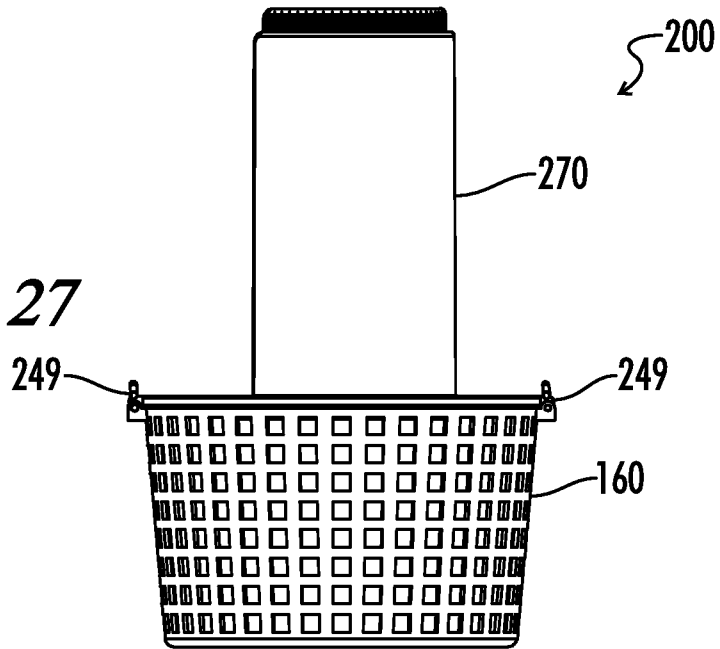
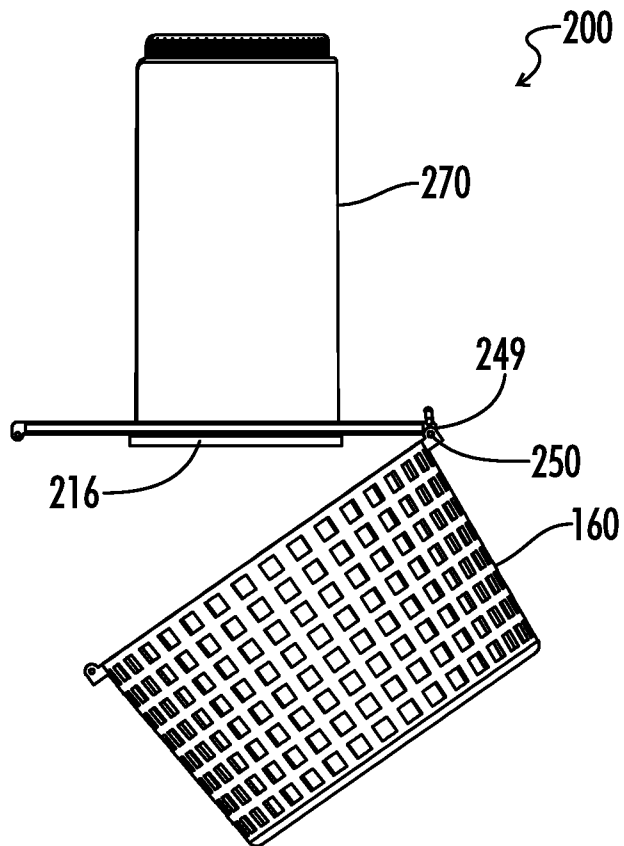

FIG. 28



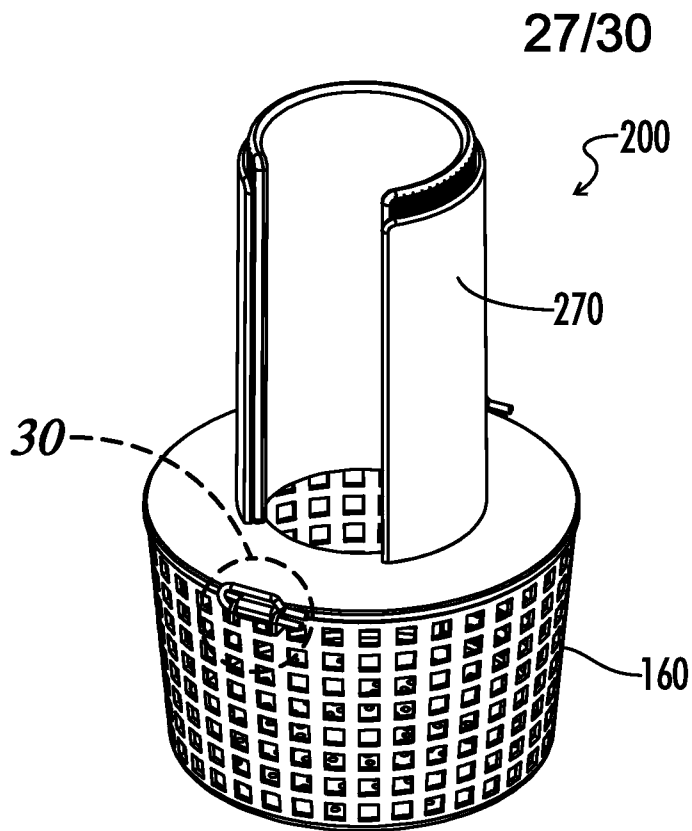

FIG. 29

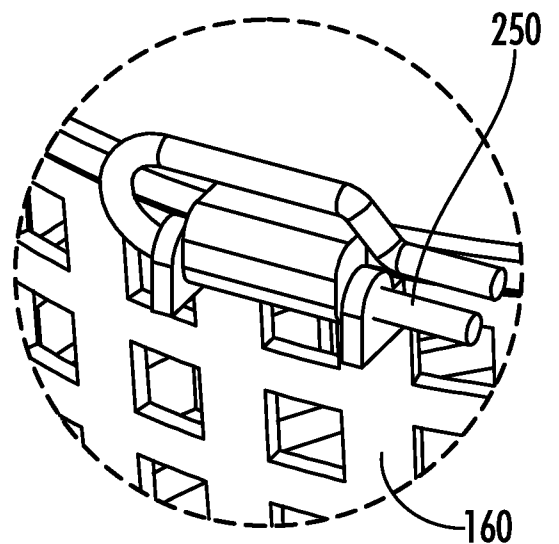

FIG. 30

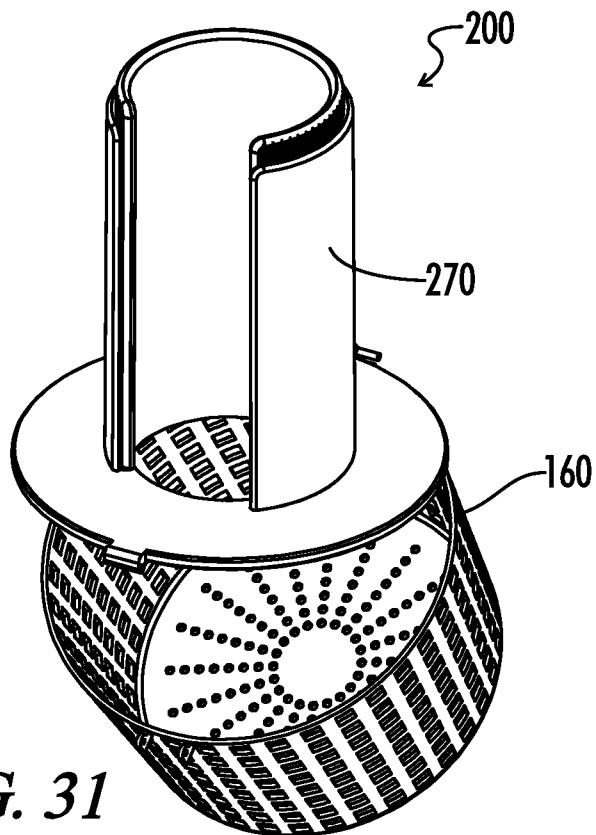

FIG. 31

28/30

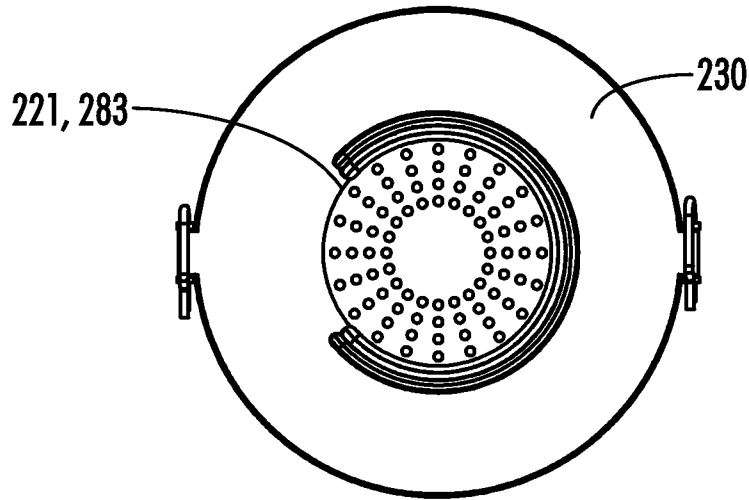

FIG. 32

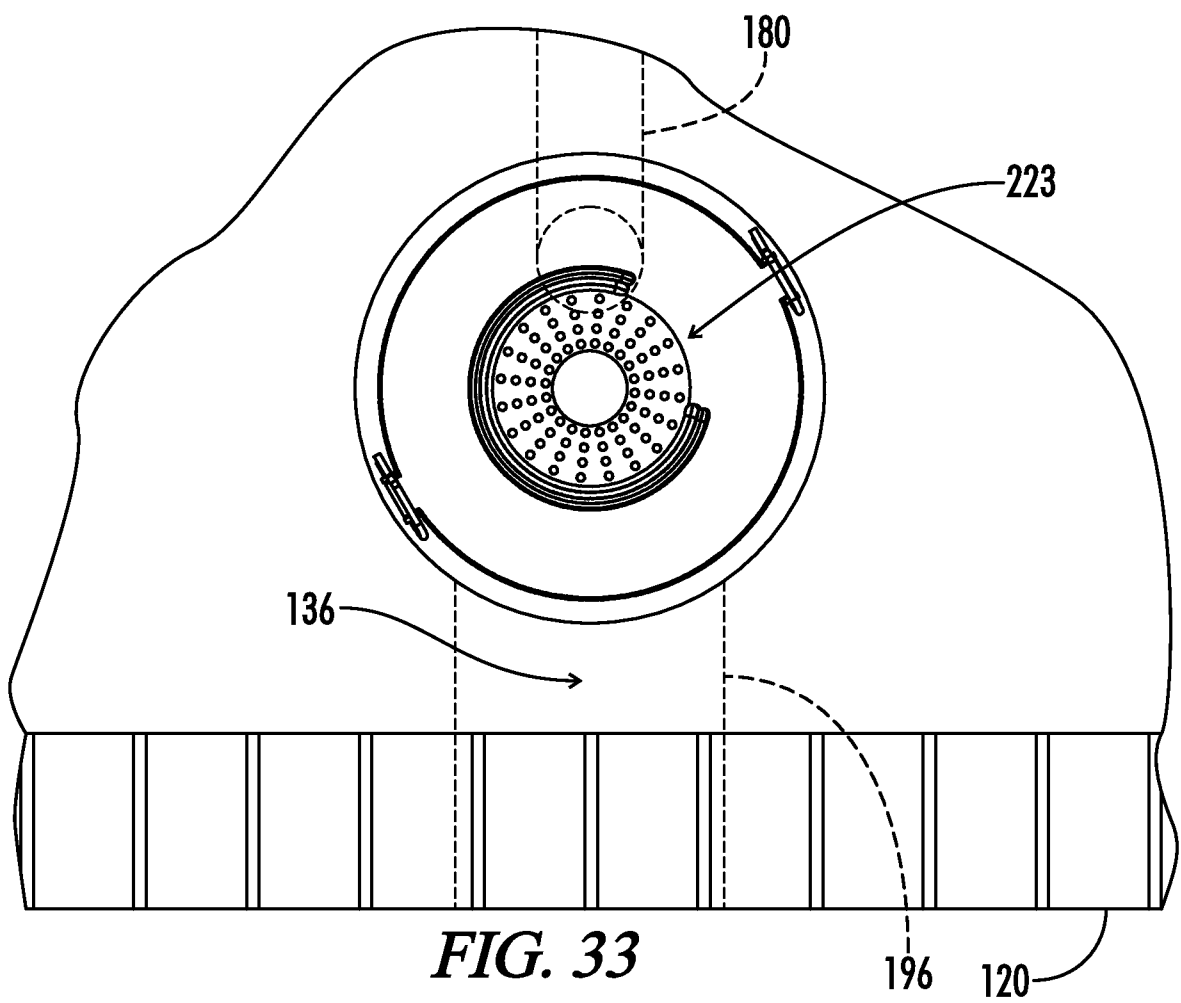

FIG. 33

29/30

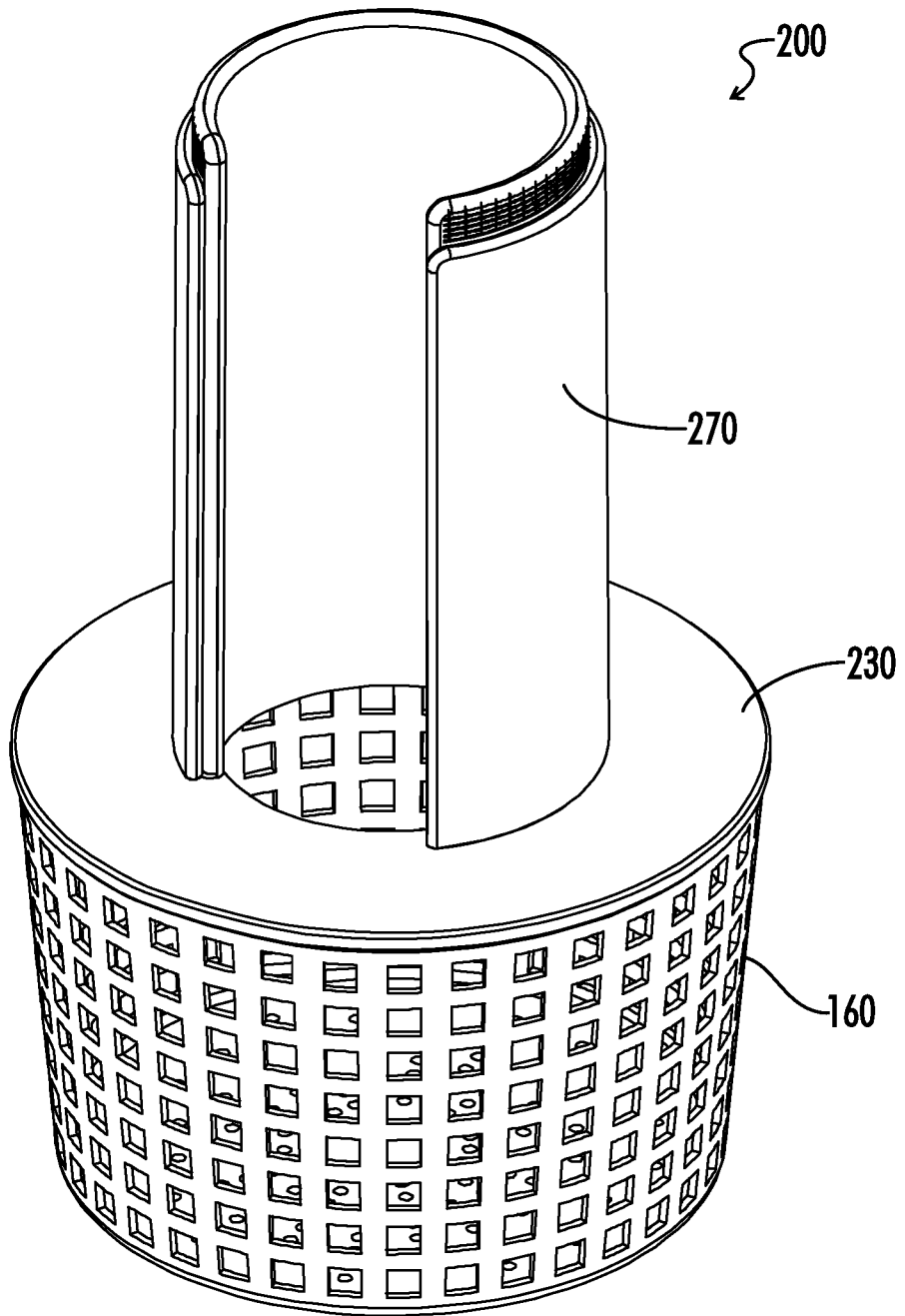
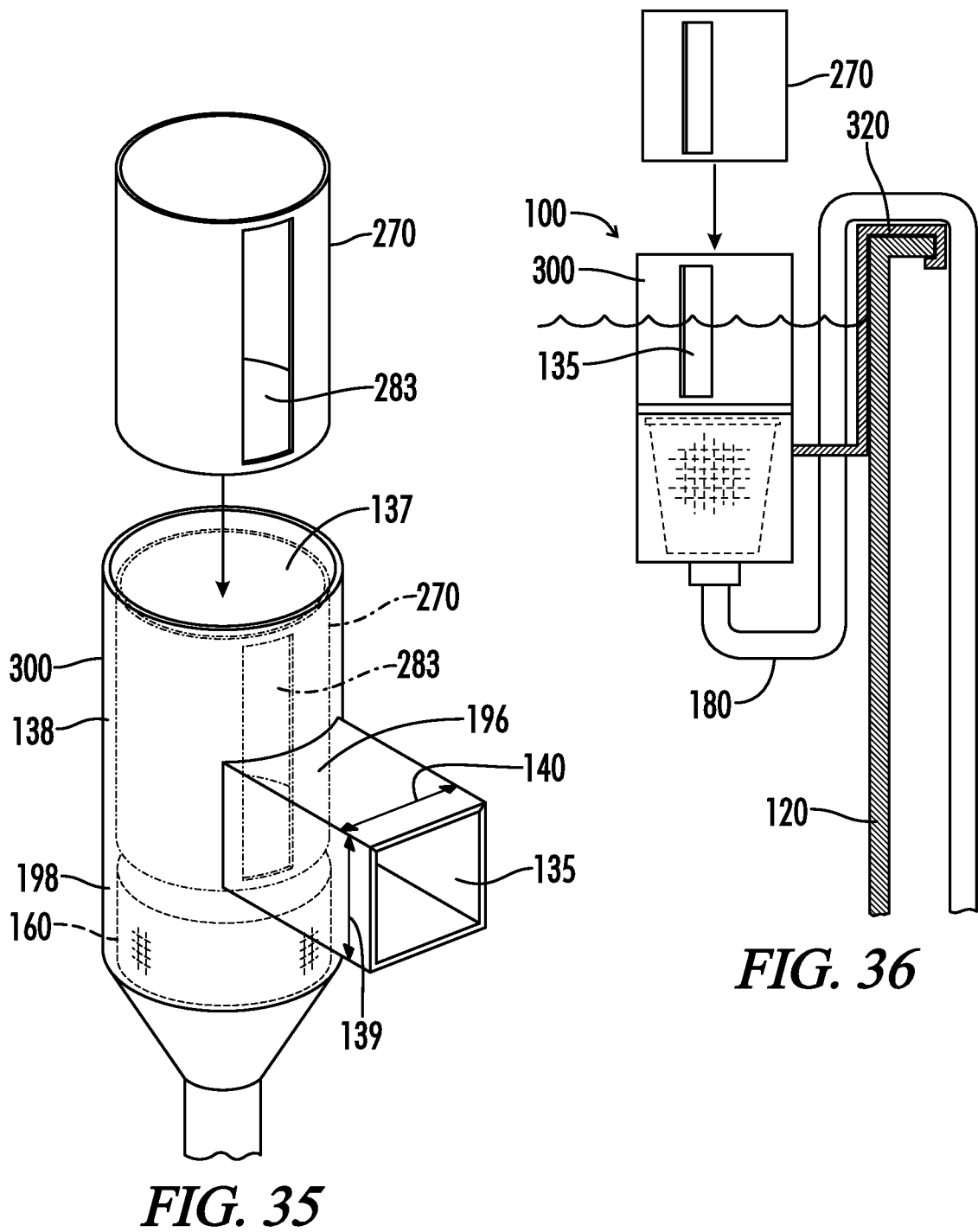

FIG. 34

30/30



INTERNATIONAL SEARCH REPORT

International application No.
PCT/US14/31757

A. CLASSIFICATION OF SUBJECT MATTER

IPC(8) - E04H 3/16, 4/12, 4/16 (2014.01)
USPC - 210/167, 167.19
According to International Patent Classification (IPC) or to both national classification and IPC

B. FIELDS SEARCHED

Minimum documentation searched (classification system followed by classification symbols)
IPC(8) - E04H 3/16, 4/00, 4/12, 4/16 (2014.01)
USPC - 210/167, 167.19

Documentation searched other than minimum documentation to the extent that such documents are included in the fields searched

Electronic data base consulted during the international search (name of data base and, where practicable, search terms used)
MicroPatent (US-G, US-A, EP-A, EP-B, WO, JP-bib, DE-C,B, DE-A, DE-T, DE-U, GB-A, FR-A); Google; Proquest; IP.com; Skimmer basket, filter basket, filter, strainer, first, tube, pipe, second, slot, slit, flange, velocity, flow, Ronnie Smith, New Technologies

C. DOCUMENTS CONSIDERED TO BE RELEVANT

Category*	Citation of document, with indication, where appropriate, of the relevant passages	Relevant to claim No.
A	US 2006/0070935 A1 (BROSEMER, BJ) April 6, 2006; abstract; figures 2-4; paragraphs [0011], [0013], [0024]; claims 1, 3	1-24, 30, 36-44
A	US 2008/0073257 A1 (FOLEY, KT) March 27, 2008; abstract; figures 2-3; paragraphs [0002], [0023], [0025]	1-24, 30, 36-44
A	US 4,737,279 A (LEWIS, K) April 12, 1988; abstract; figures 1, 3, 5; column 1, lines 7-8; column 3, lines 38-40; column 4, lines 9-50; column 5, lines 13-14; column 7, lines 30-33, column 8, lines 2-4	1-44
A	US 2008/0099387 A1 (PELLINGTON, GS et al.) May 1, 2008; abstract; figures 2-3; paragraphs [0004], [0011], [0016]-[0017], [0030]	1-24, 30, 36-44
A	US 4,818,389 A (TOBIAS, S et al.) April 4, 1989; abstract	25-29, 31-35
A	US 5,265,631 A (GOETTL, JM) November 30, 1993; figure 3; column 6, lines 30-32	25-29, 31-35
A	US 6,932,899 B2 (BONELLI, JJ et al.) August 23, 2005; abstract	25-29, 31-35
A	US 8,512,555 B1 (ALLEN, II, VP et al.) August 20, 2013; entire document	1-44
A	US 3,428,178 A (NASH, FM) February 18, 1969; entire document	1-44

Further documents are listed in the continuation of Box C.

* Special categories of cited documents:	
"A" document defining the general state of the art which is not considered to be of particular relevance	"T" later document published after the international filing date or priority date and not in conflict with the application but cited to understand the principle or theory underlying the invention
"E" earlier application or patent but published on or after the international filing date	"X" document of particular relevance; the claimed invention cannot be considered novel or cannot be considered to involve an inventive step when the document is taken alone
"L" document which may throw doubts on priority claim(s) or which is cited to establish the publication date of another citation or other special reason (as specified)	"Y" document of particular relevance; the claimed invention cannot be considered to involve an inventive step when the document is combined with one or more other such documents, such combination being obvious to a person skilled in the art
"O" document referring to an oral disclosure, use, exhibition or other means	"&" document member of the same patent family
"P" document published prior to the international filing date but later than the priority date claimed	

Date of the actual completion of the international search
18 July 2014 (18.07.2014)

Date of mailing of the international search report

11 AUG 2014

Name and mailing address of the ISA/US
Mail Stop PCT, Attn: ISA/US, Commissioner for Patents
P.O. Box 1450, Alexandria, Virginia 22313-1450
Facsimile No. 571-273-3201

Authorized officer:
Shane Thomas

PCT Helpdesk: 571-272-4300
PCT OSP: 571-272-7774

INTERNATIONAL SEARCH REPORT

International application No.

PCT/US14/31757

C (Continuation). DOCUMENTS CONSIDERED TO BE RELEVANT		
Category*	Citation of document, with indication, where appropriate, of the relevant passages	Relevant to claim No.
A	US 5,814,213 A (GLASGOW, JA) September 29, 1998; entire document	1-44
T, X	US 8,721,881 B1 (SMITH, RE) May 13, 2014; entire document	1-44