



US 20180299229A1

(19) **United States**

(12) **Patent Application Publication**
Cohen

(10) **Pub. No.: US 2018/0299229 A1**

(43) **Pub. Date: Oct. 18, 2018**

(54) **REACTIVE ARMOR**

Publication Classification

(71) Applicant: **David Cohen**, Herzeliya (IL)

(51) **Int. Cl.**
F41H 5/007 (2006.01)
F41H 5/04 (2006.01)
F41H 7/04 (2006.01)

(72) Inventor: **David Cohen**, Herzeliya (IL)

(52) **U.S. Cl.**
CPC *F41H 5/007* (2013.01); *F41H 7/04* (2013.01); *F41H 5/04* (2013.01)

(21) Appl. No.: **15/768,636**

(22) PCT Filed: **Aug. 30, 2016**

(57) **ABSTRACT**

(86) PCT No.: **PCT/IL2016/050949**

§ 371 (c)(1),

(2) Date: **Apr. 16, 2018**

Reactive armour comprises an explosive reactive armour module comprising a first triggering screen and an explosive layer; and at least one explosive module placed in proximity to the reactive armour module and connected to said first triggering screen for detonation. The reactive armour module may have shaped charges to produce a shaped wavefront, and the triggering screen may be divided into at least two triggering parts, each part triggered by a different approach angle of an incoming projectile and each part configured to initiate an explosion in a different part of the reactive armour module or in a different explosive module if provided.

(30) **Foreign Application Priority Data**

Oct. 22, 2015 (IL) 242227
Jan. 7, 2016 (IL) 243521

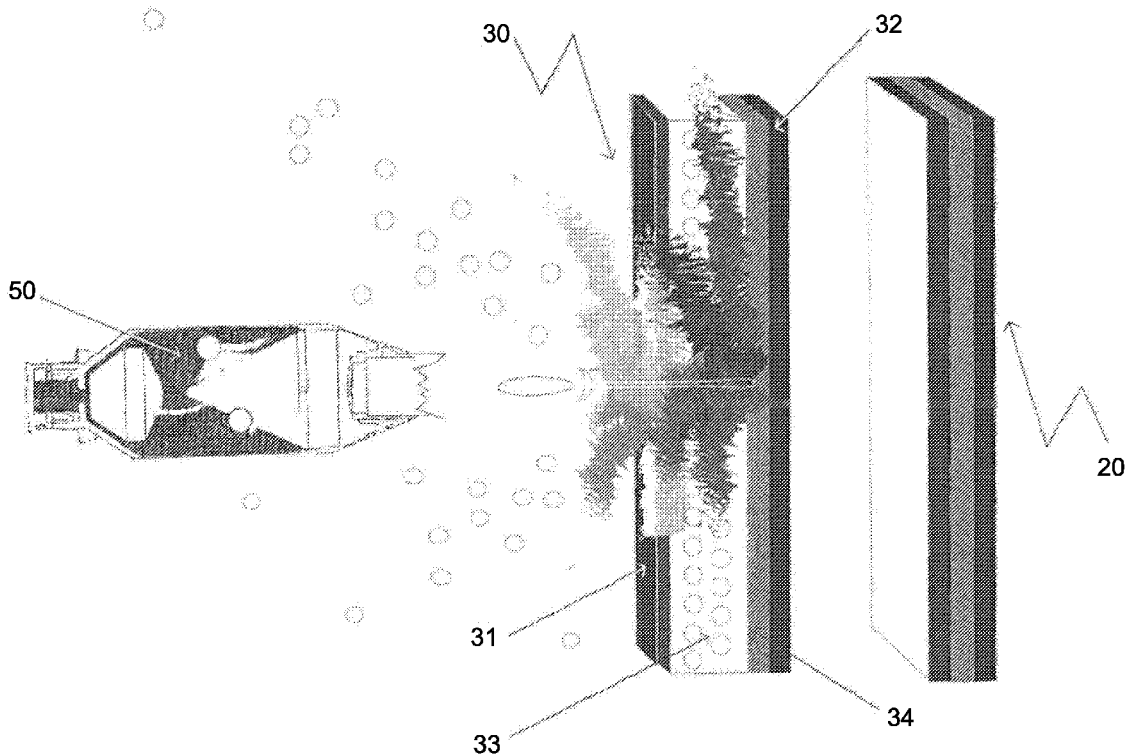

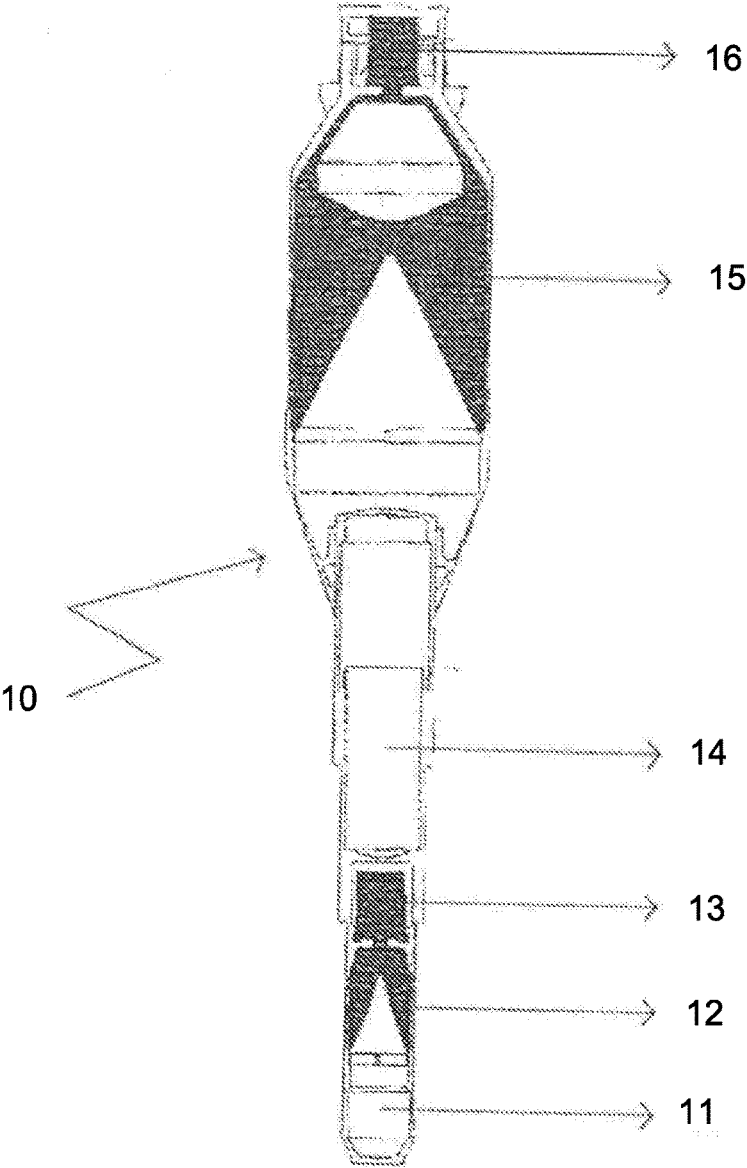

Fig. 1

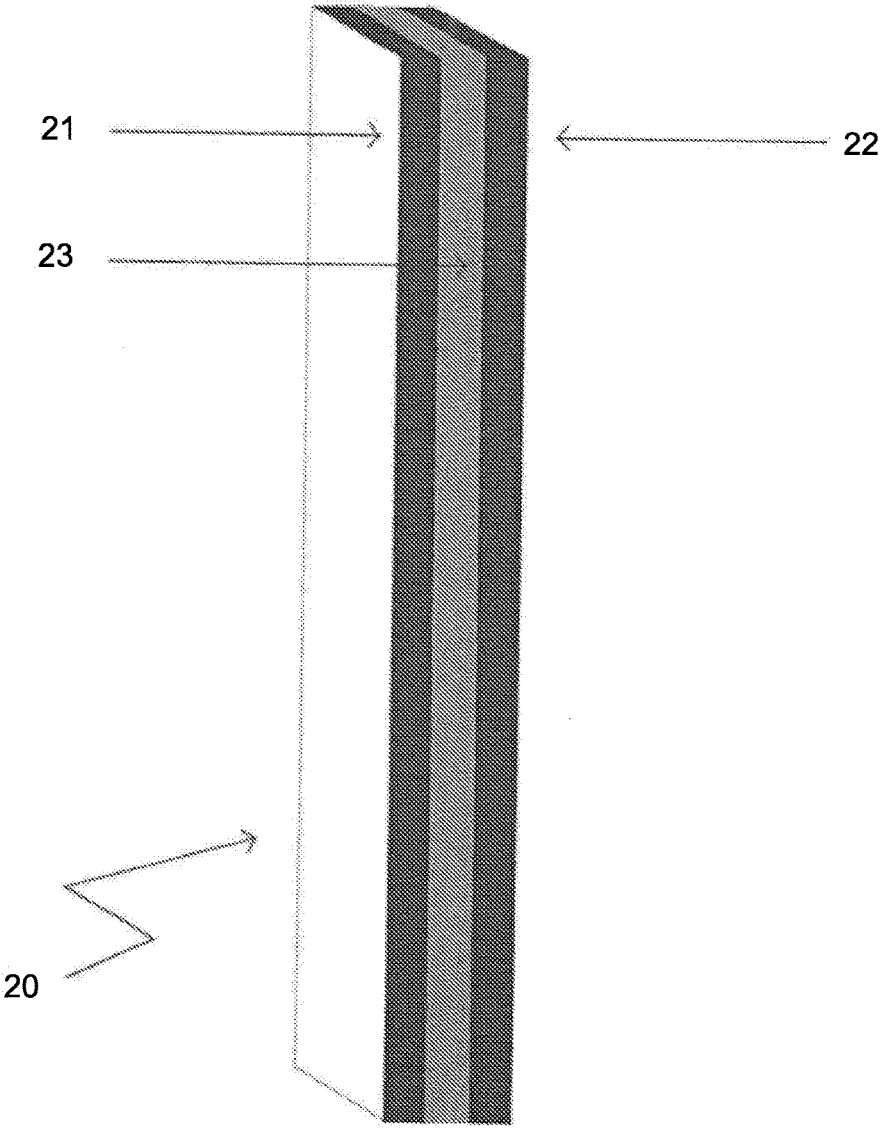

Fig. 2

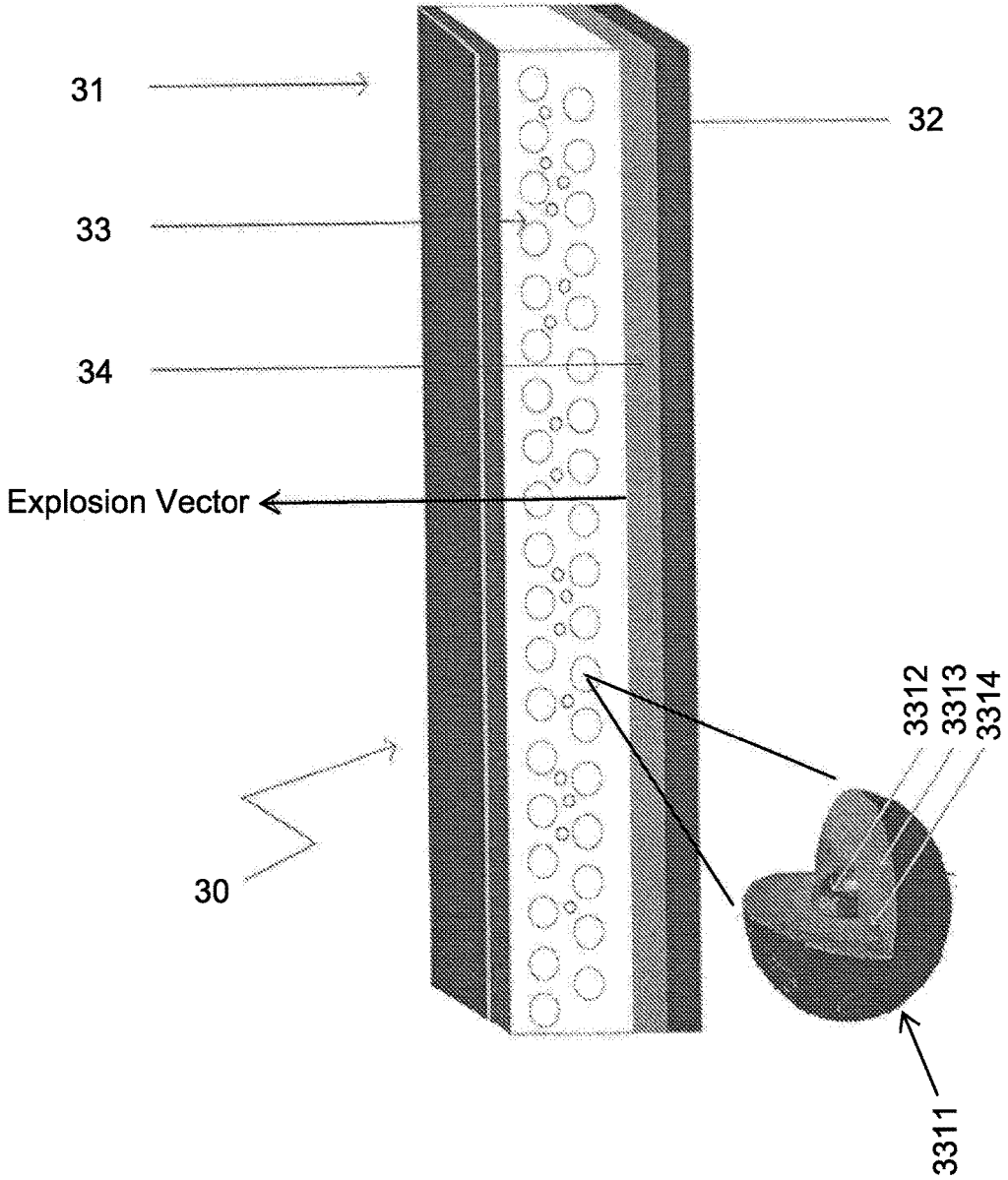

Fig. 3

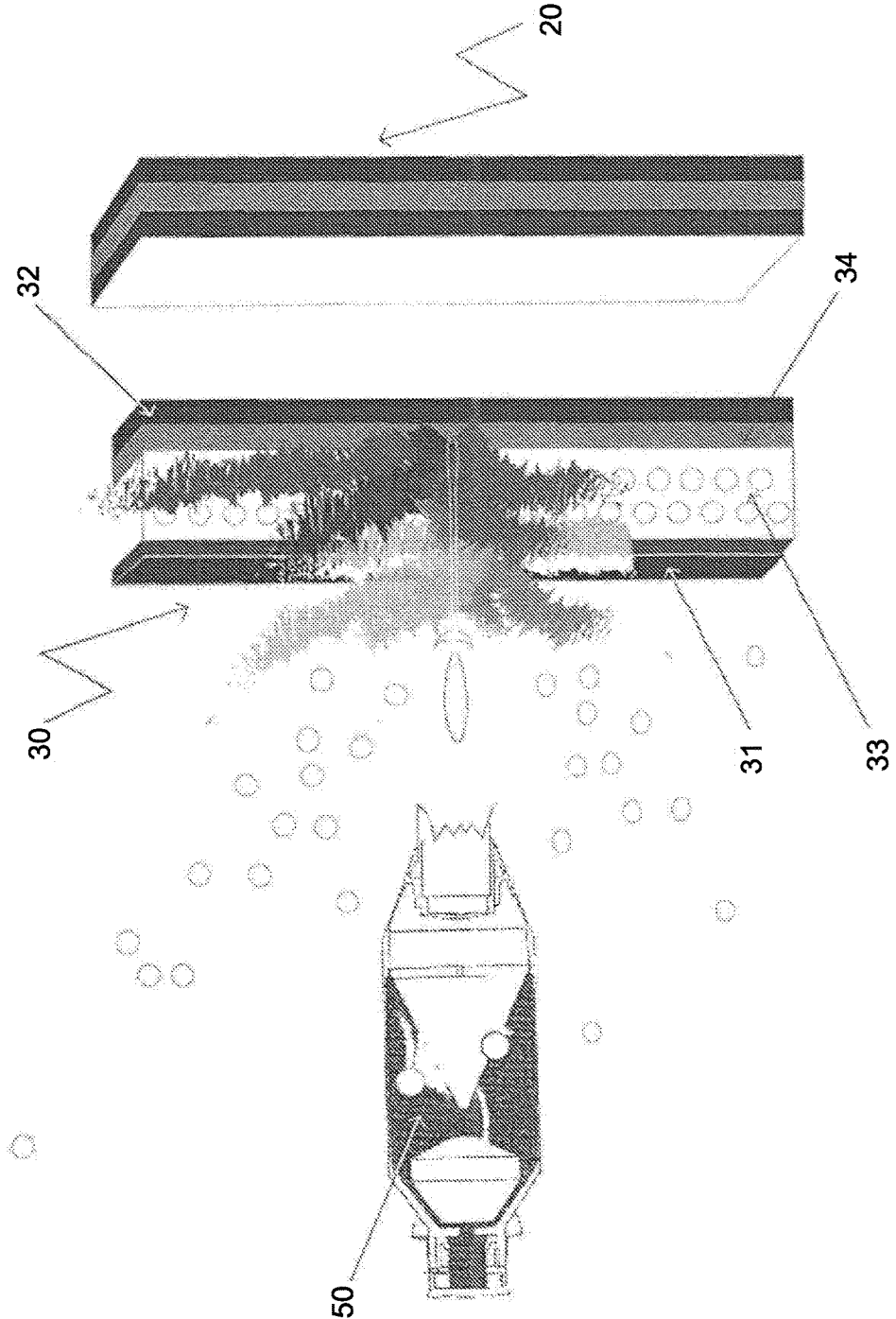

Fig. 4

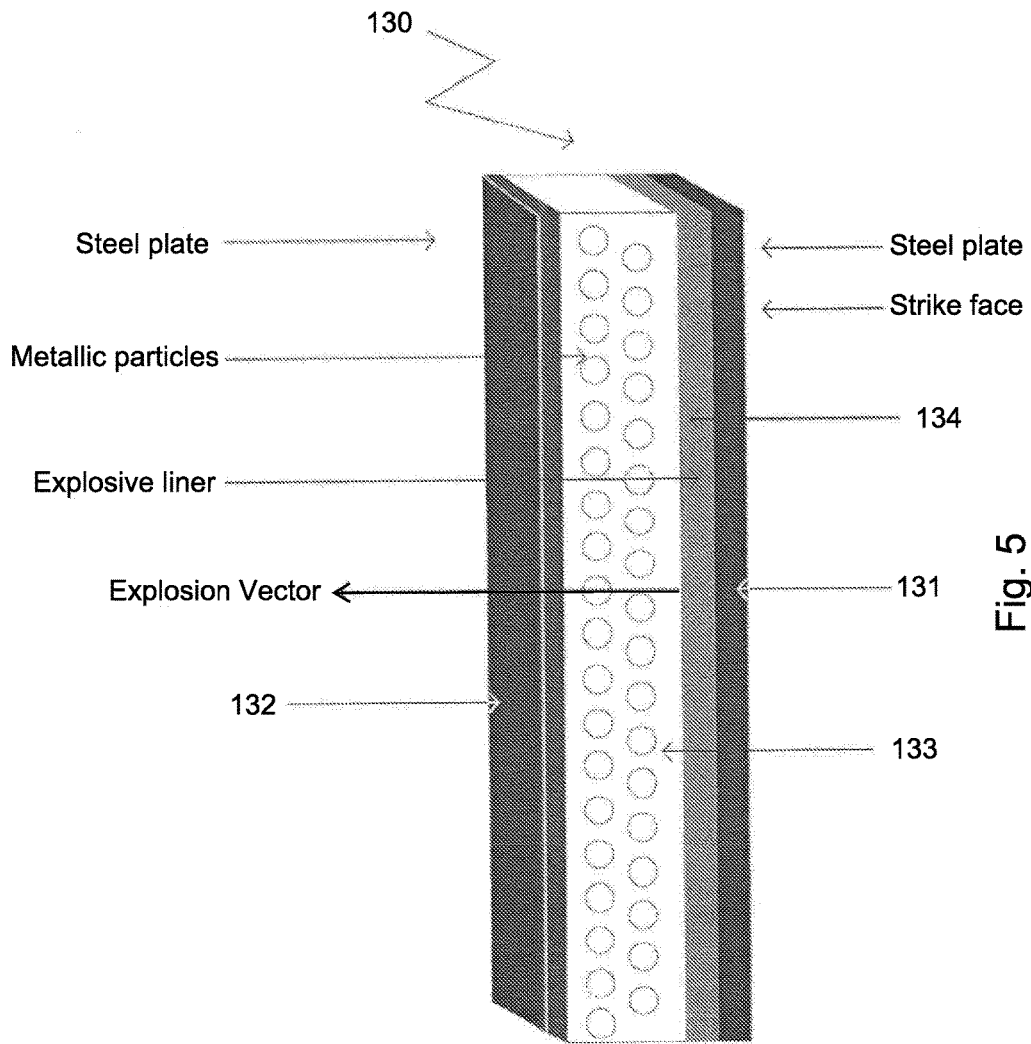

Fig. 5

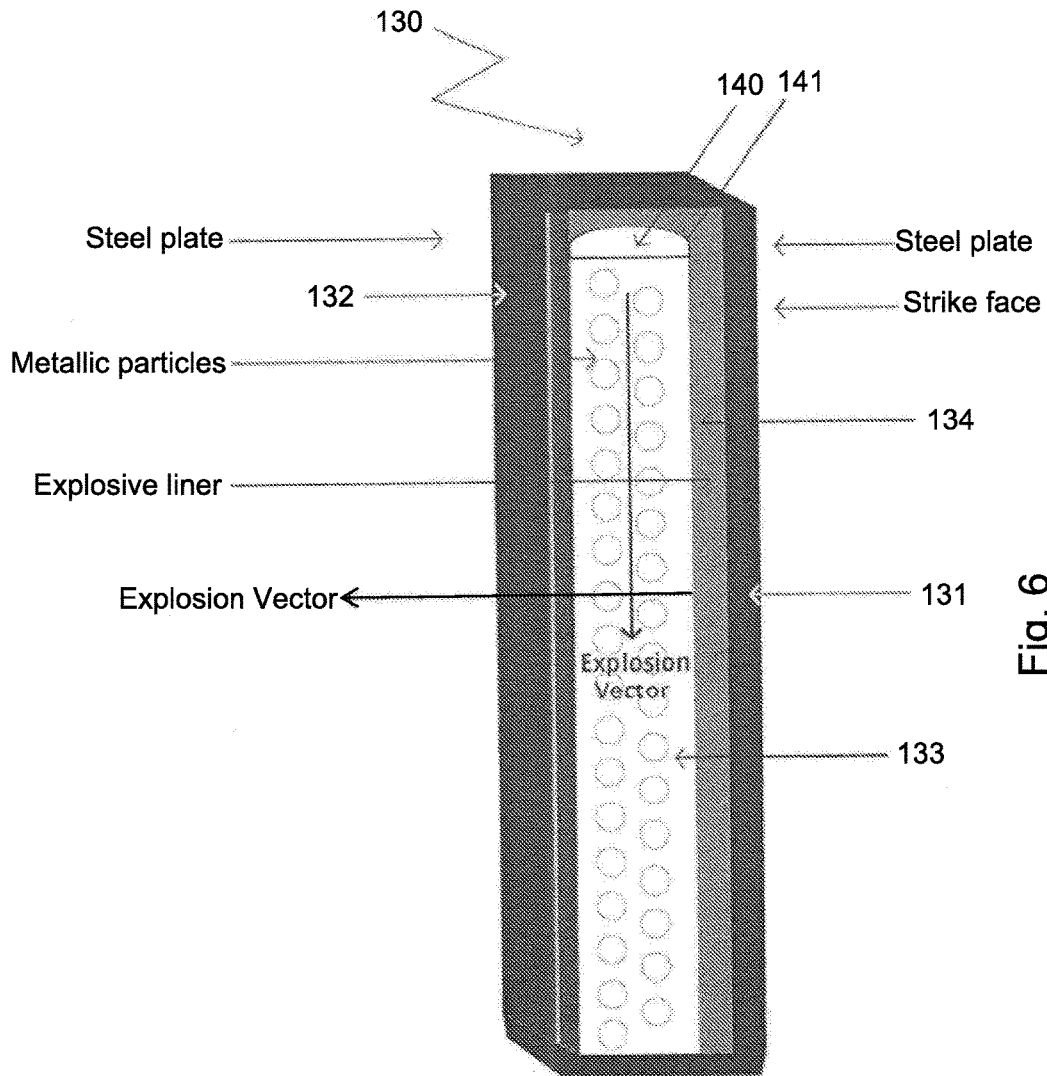

Fig. 6

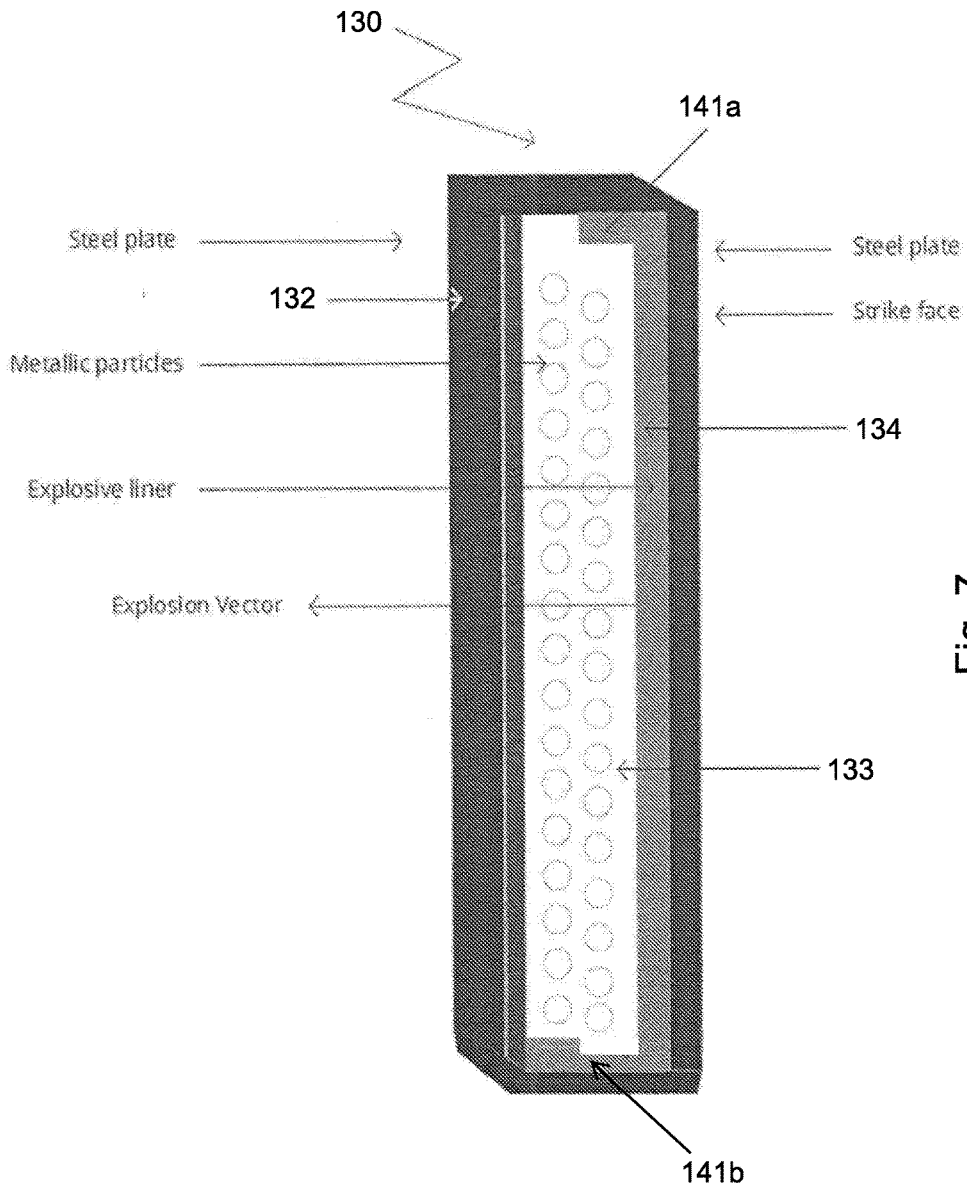
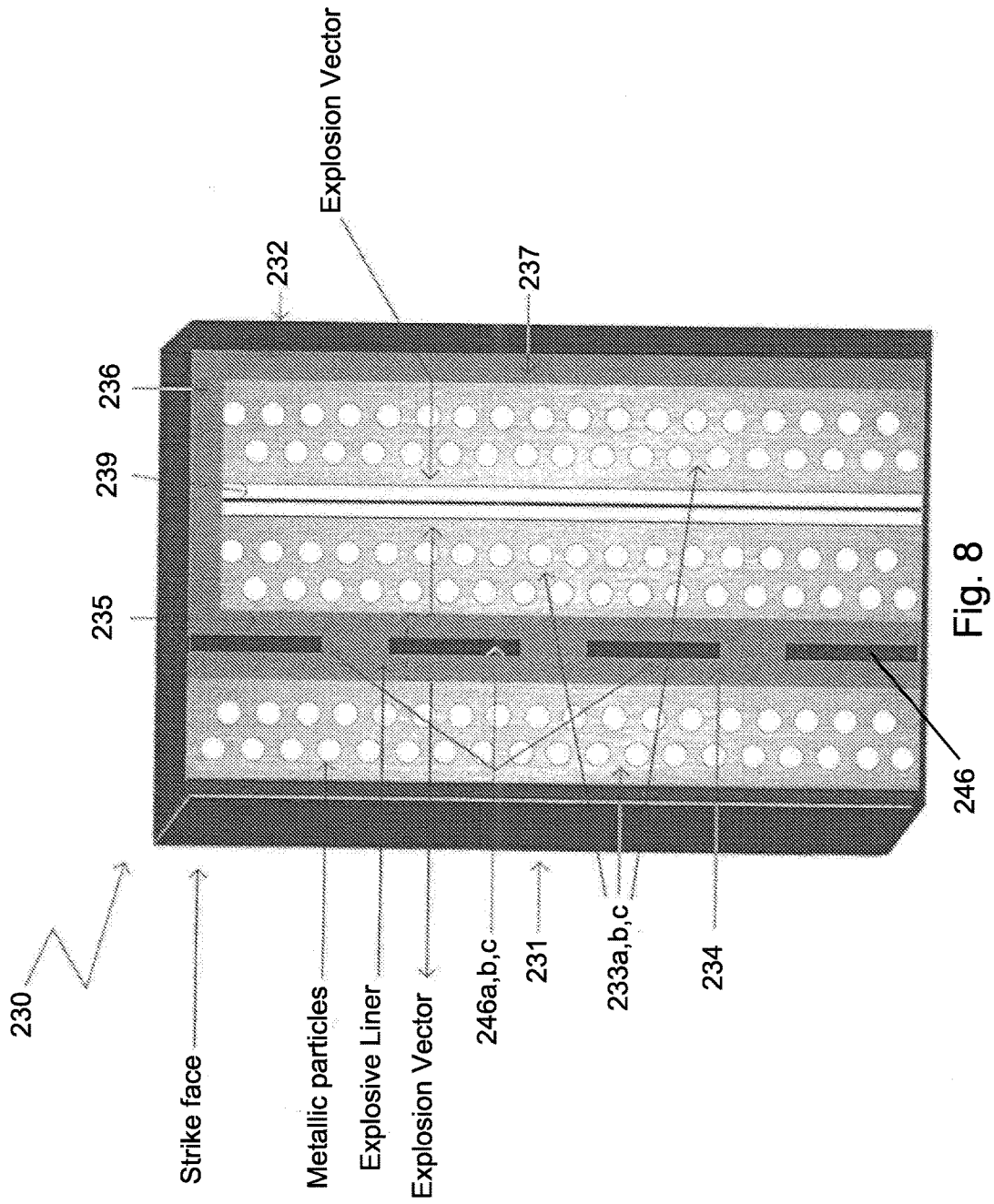

Fig. 7



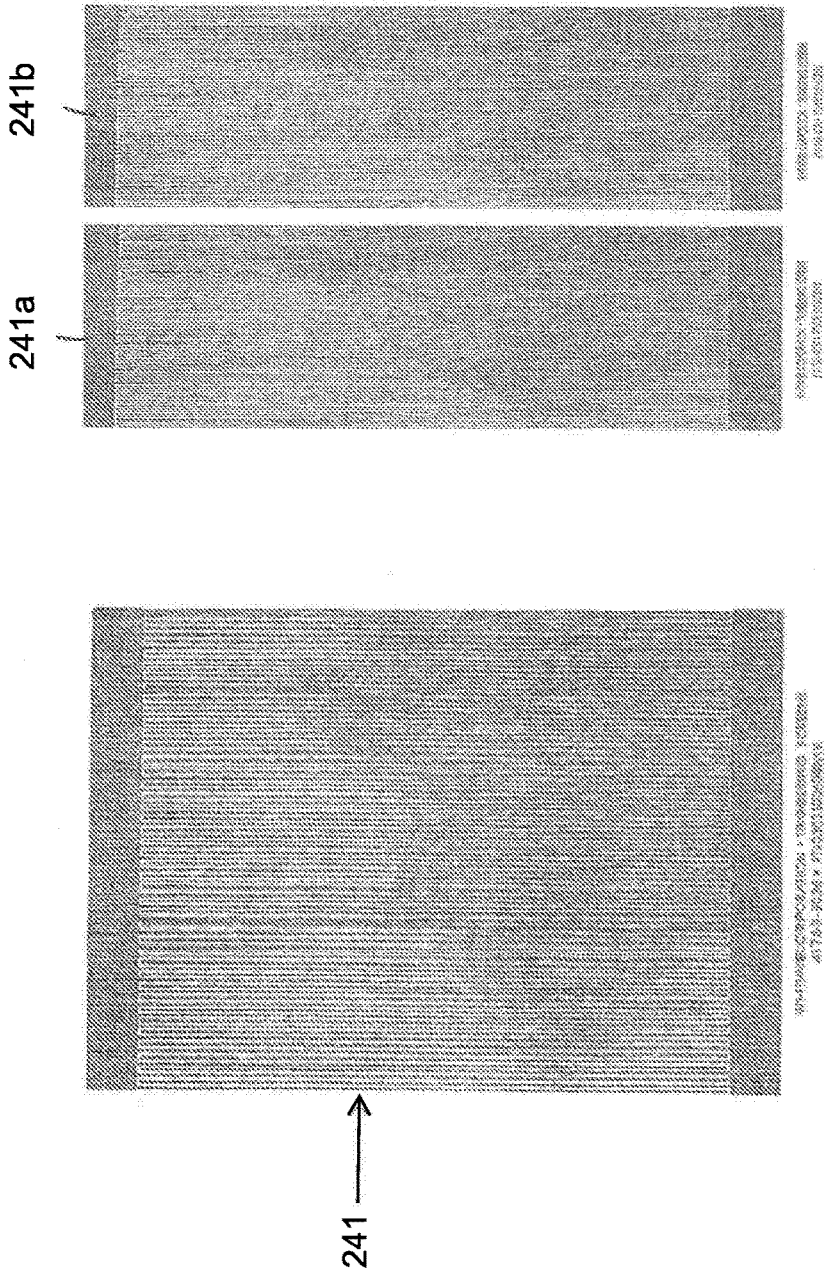

Fig. 9

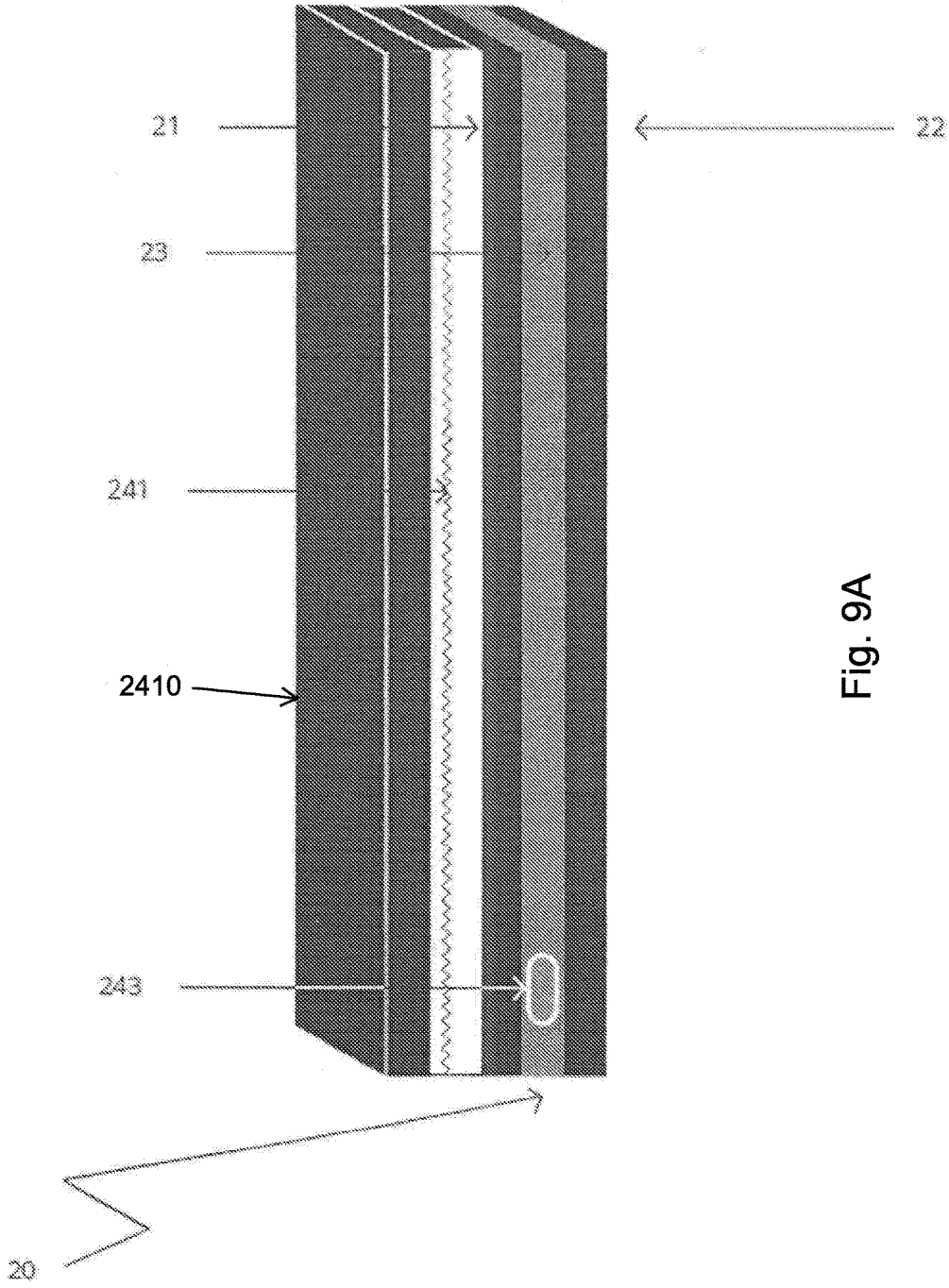

Fig. 9A

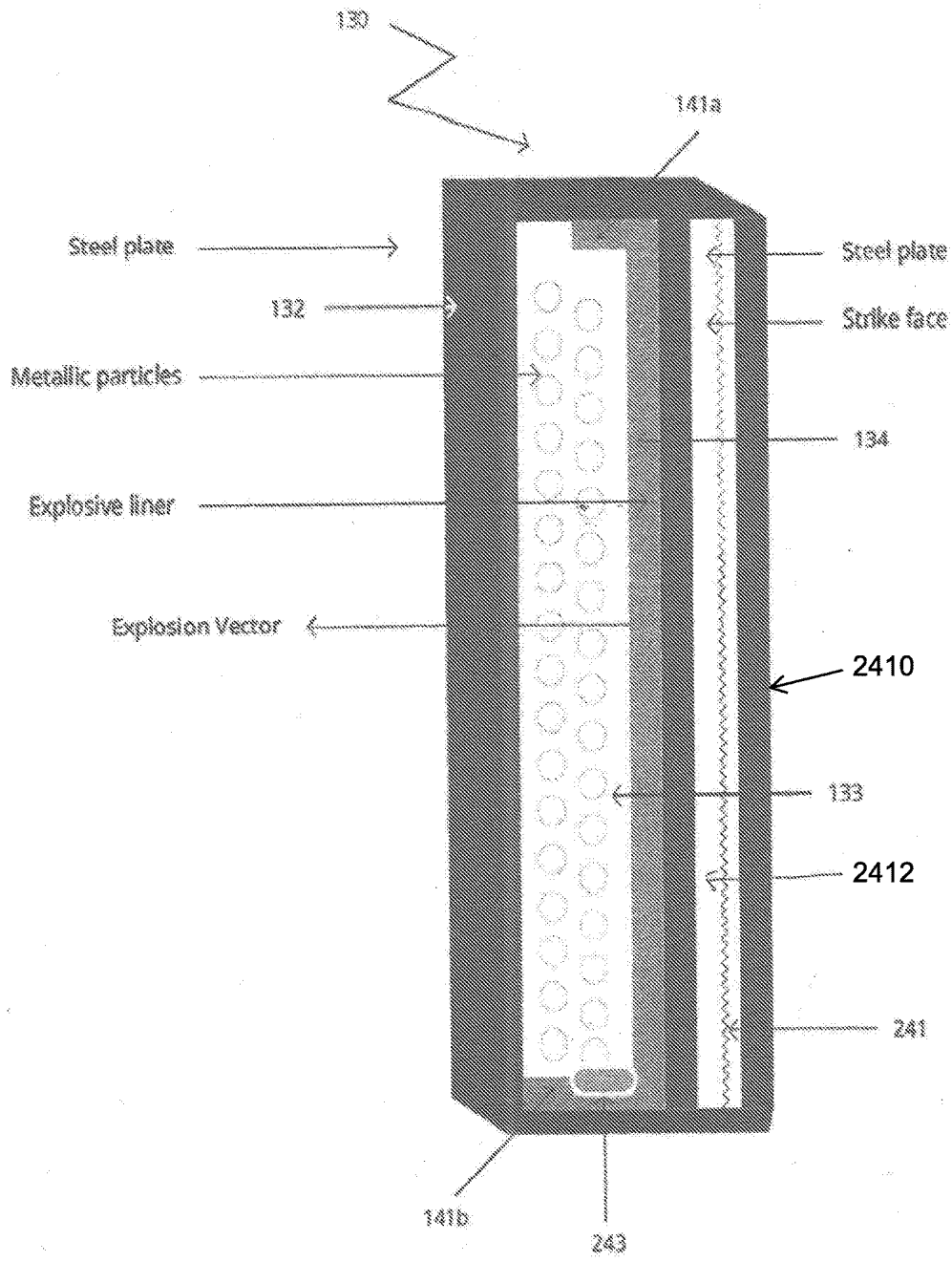

Fig. 9B

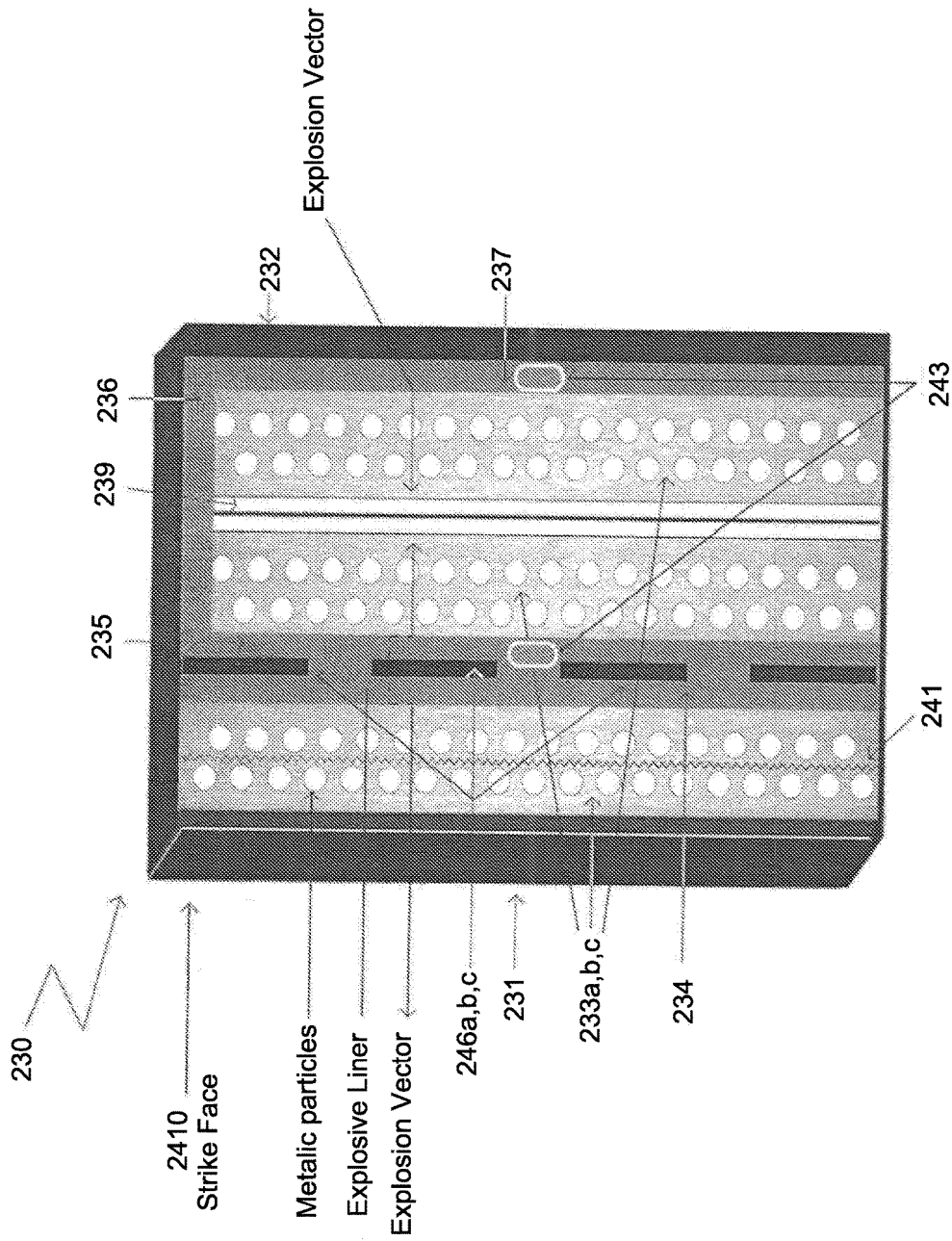

Fig. 9C

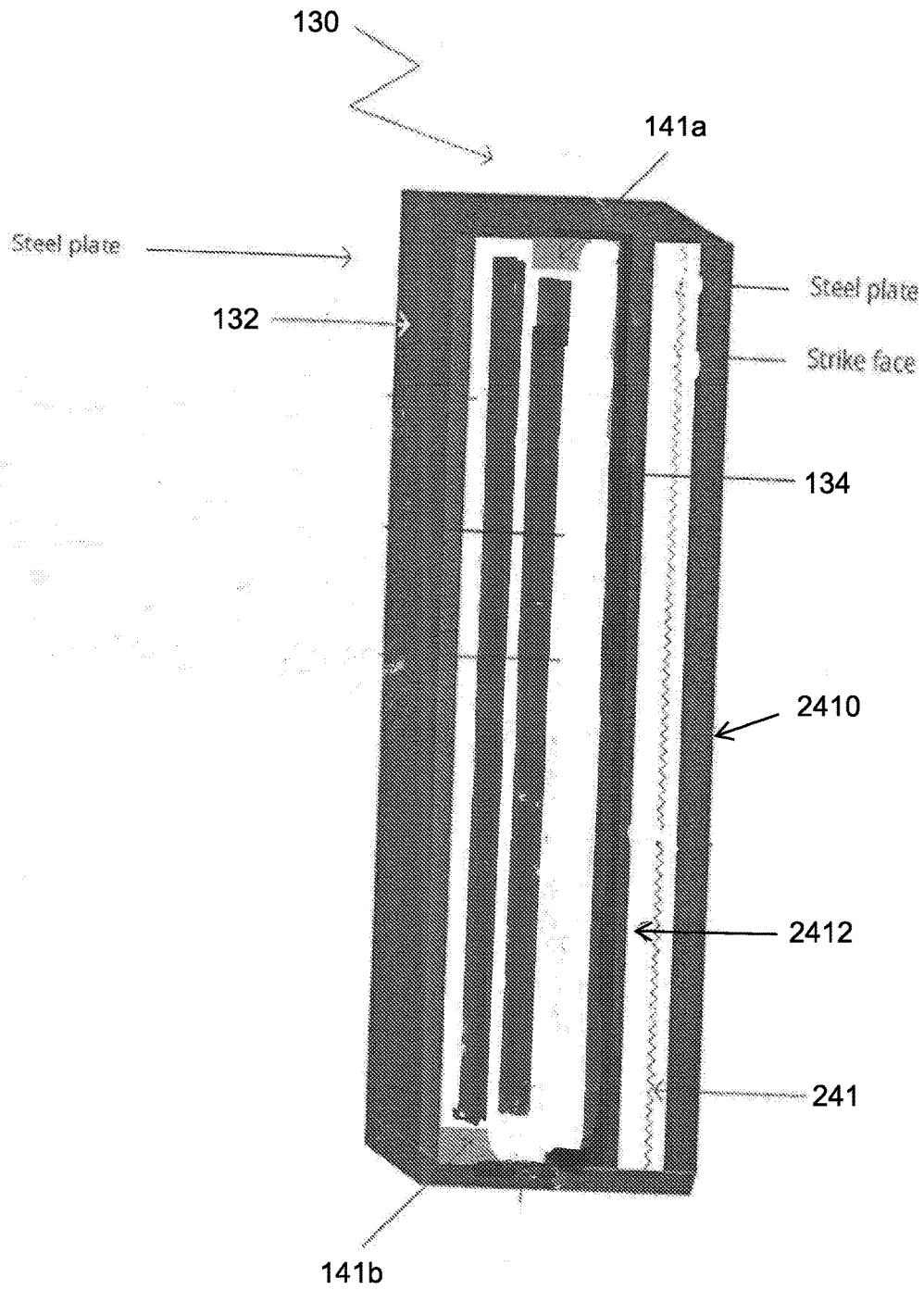

Fig. 9D

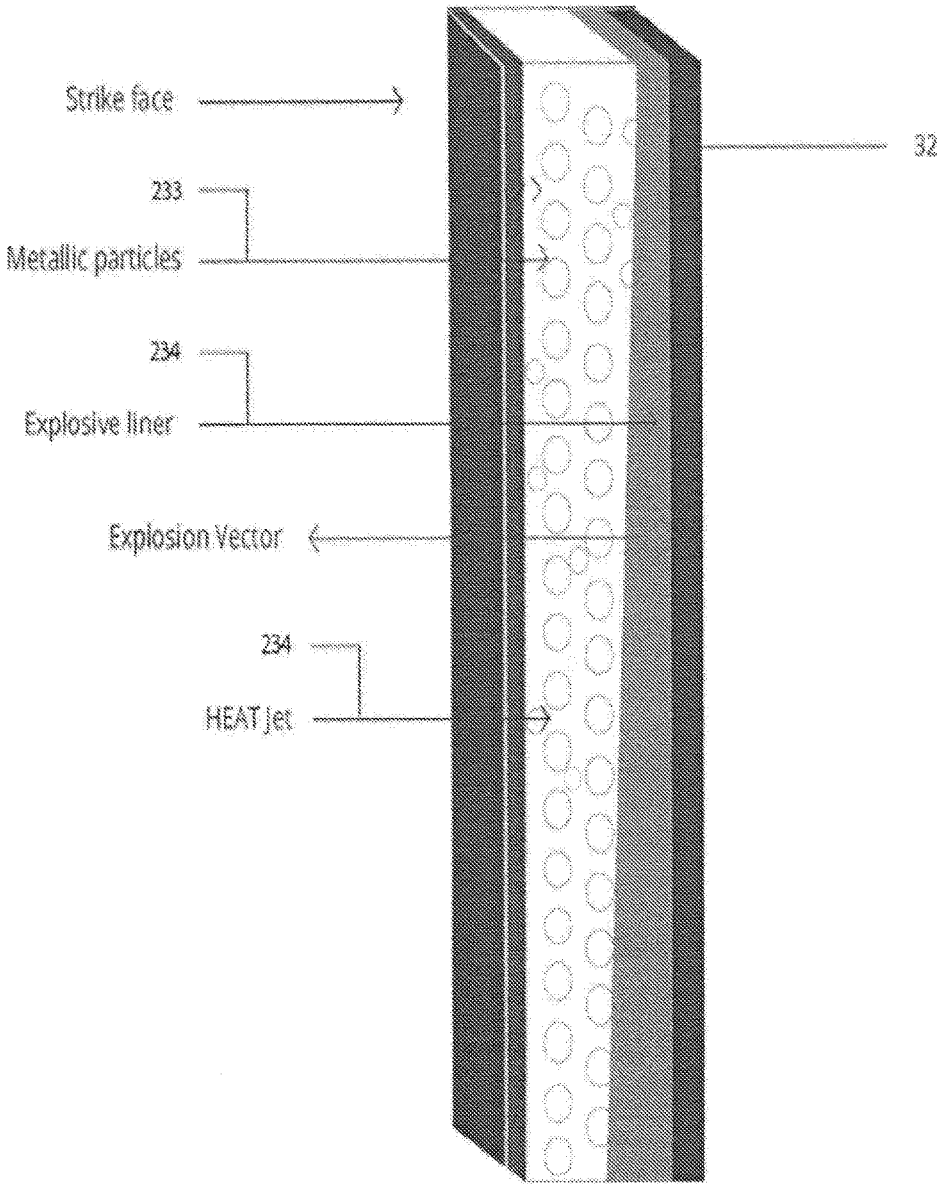

FIG 10

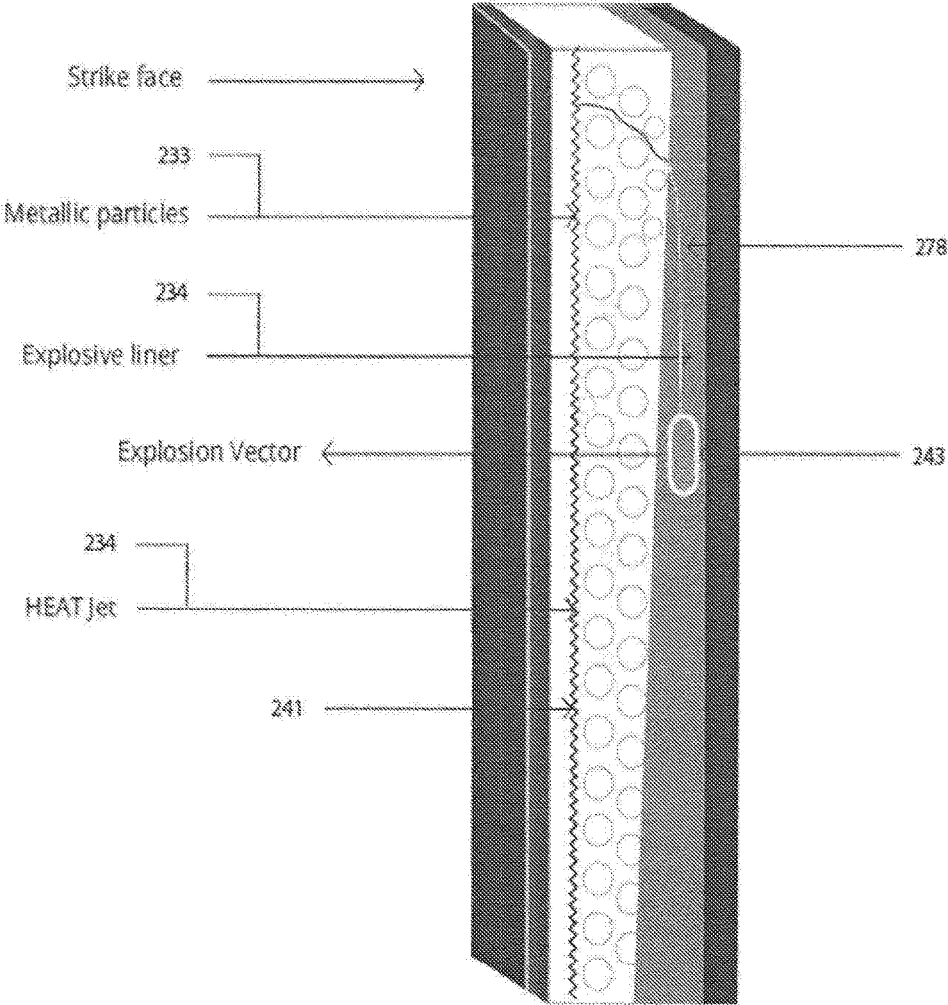

Fig 11

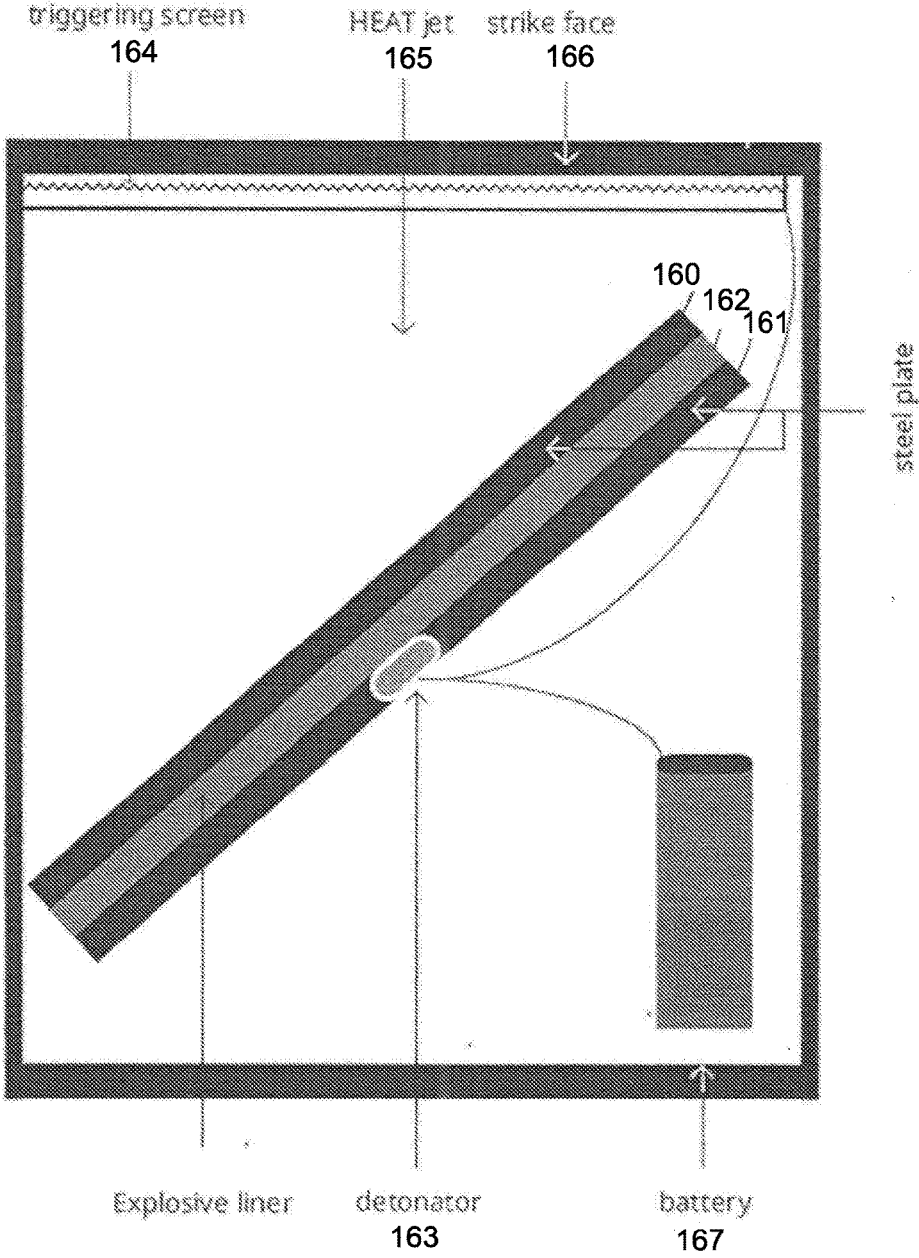

Fig 12

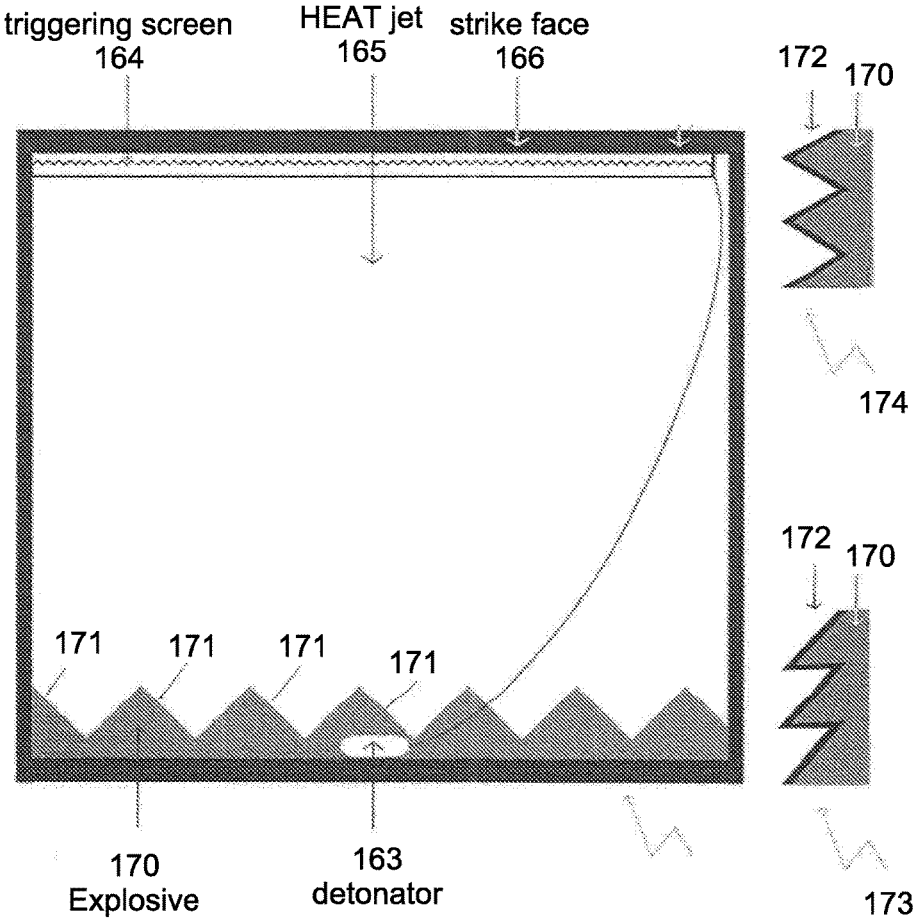

Fig. 13

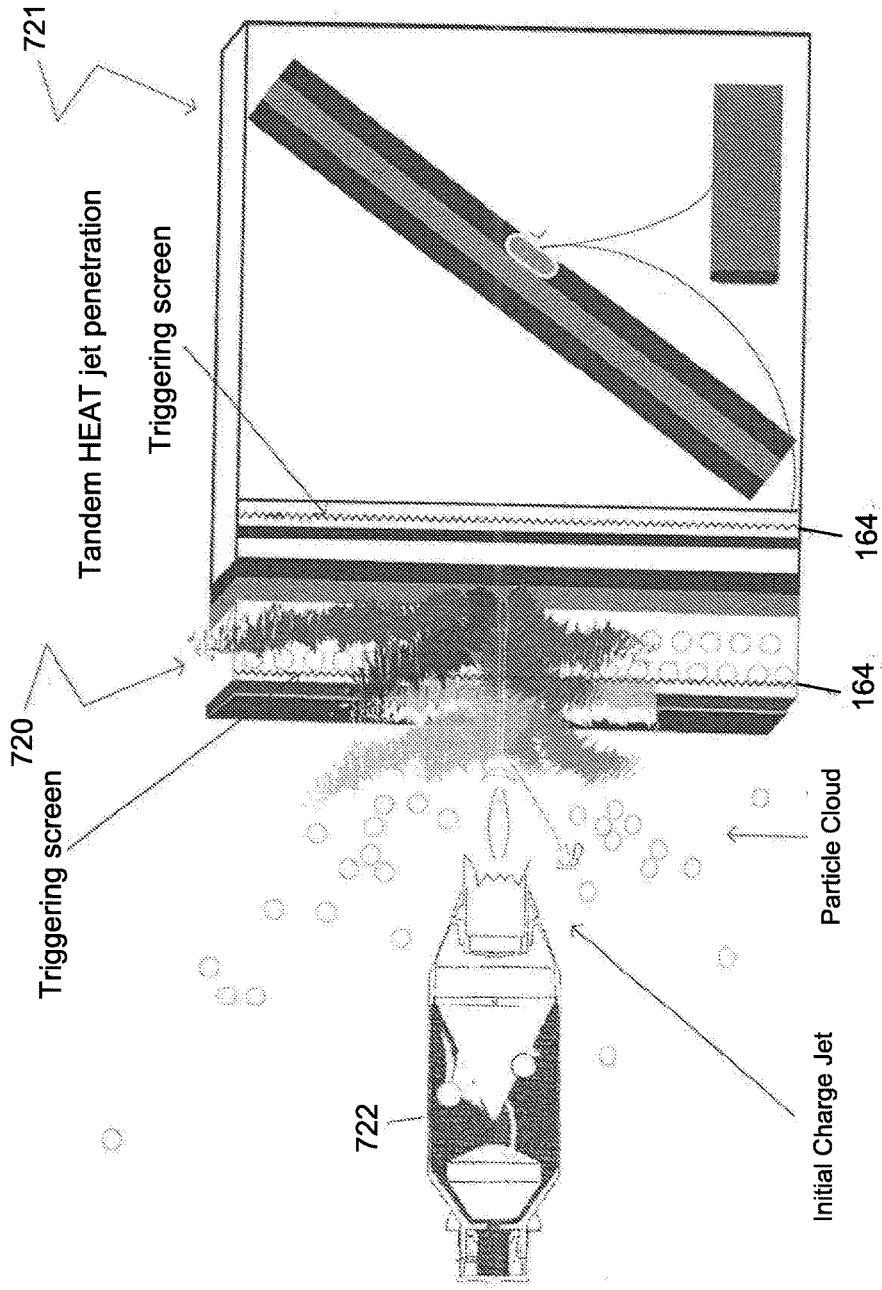

Fig 14

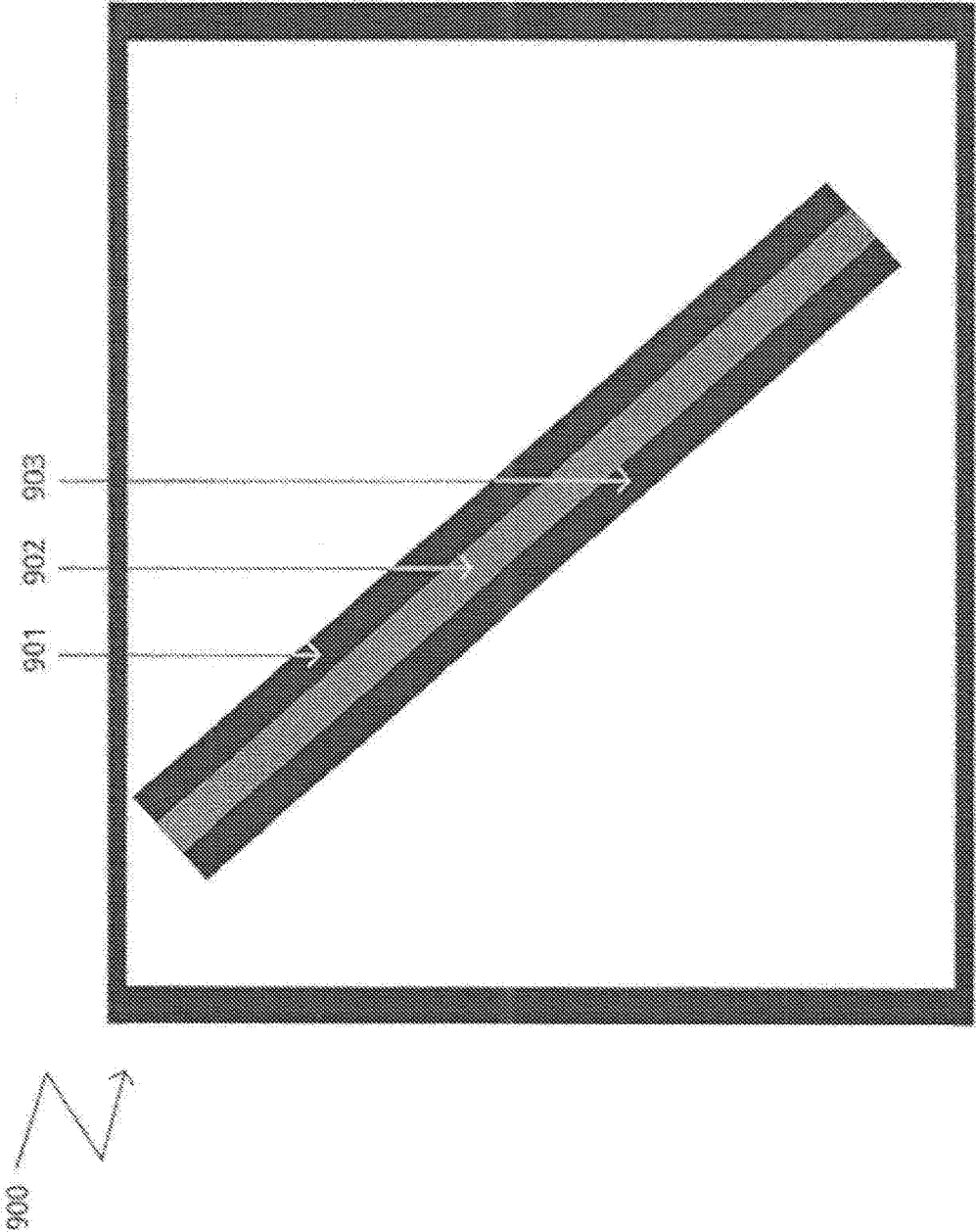

Fig 15A

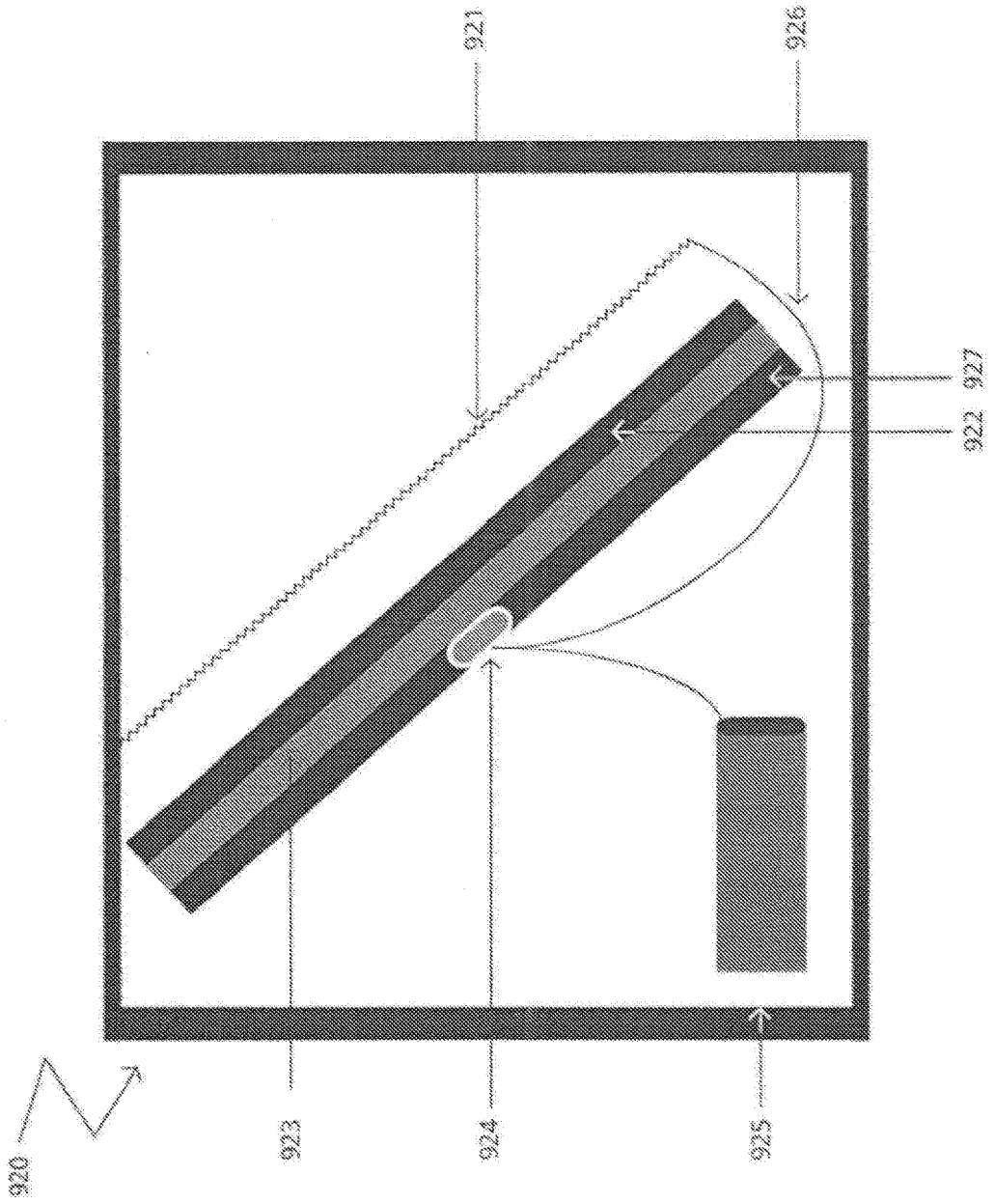

Fig 15B

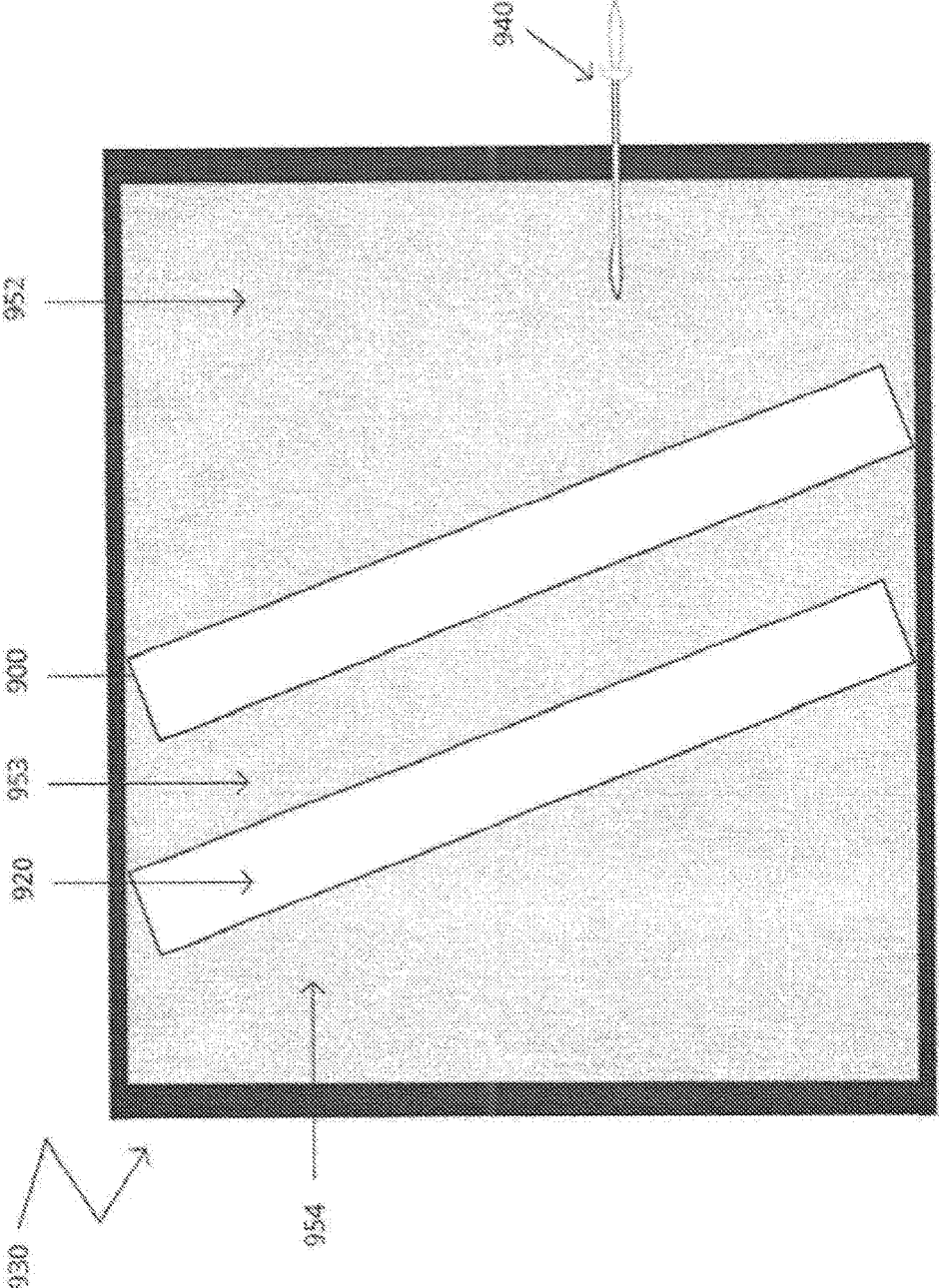

Fig 15C

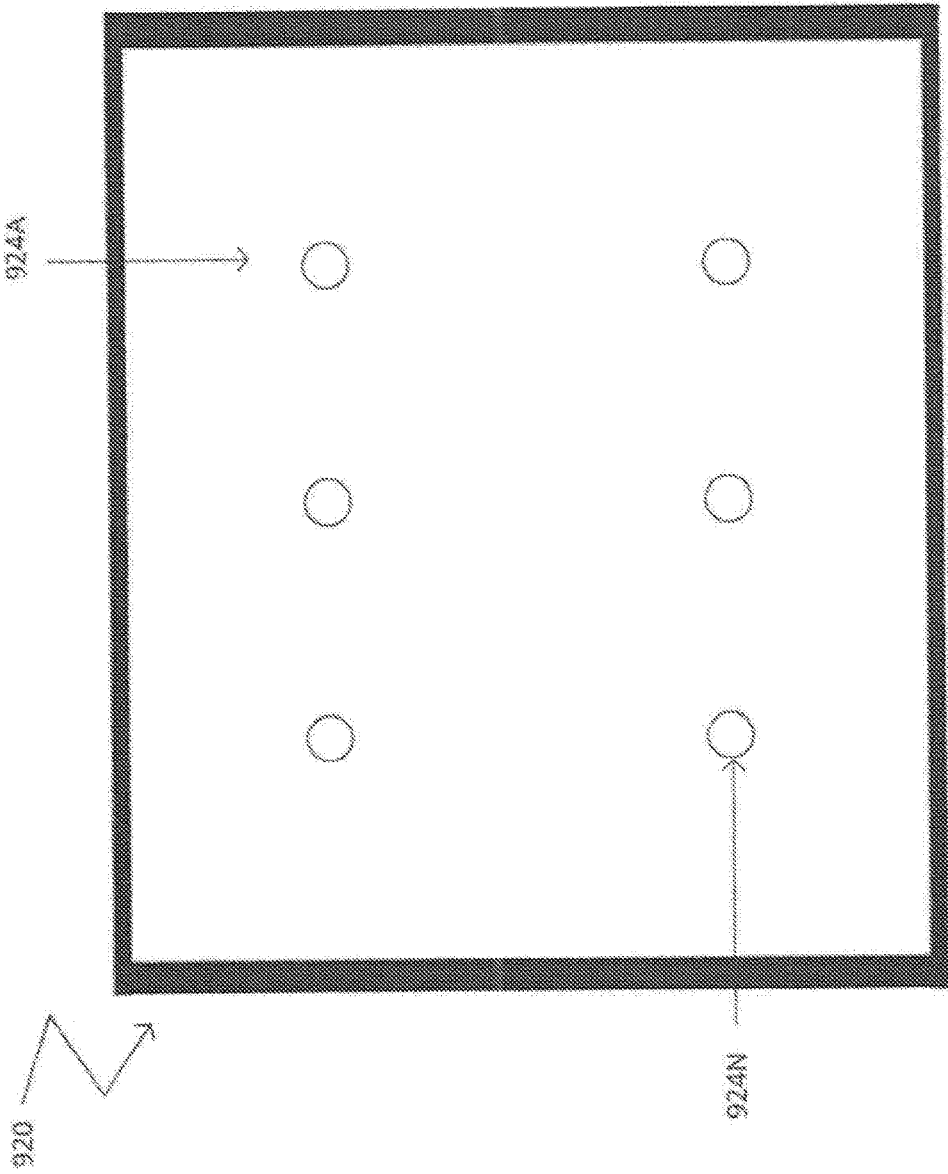

Fig 15D

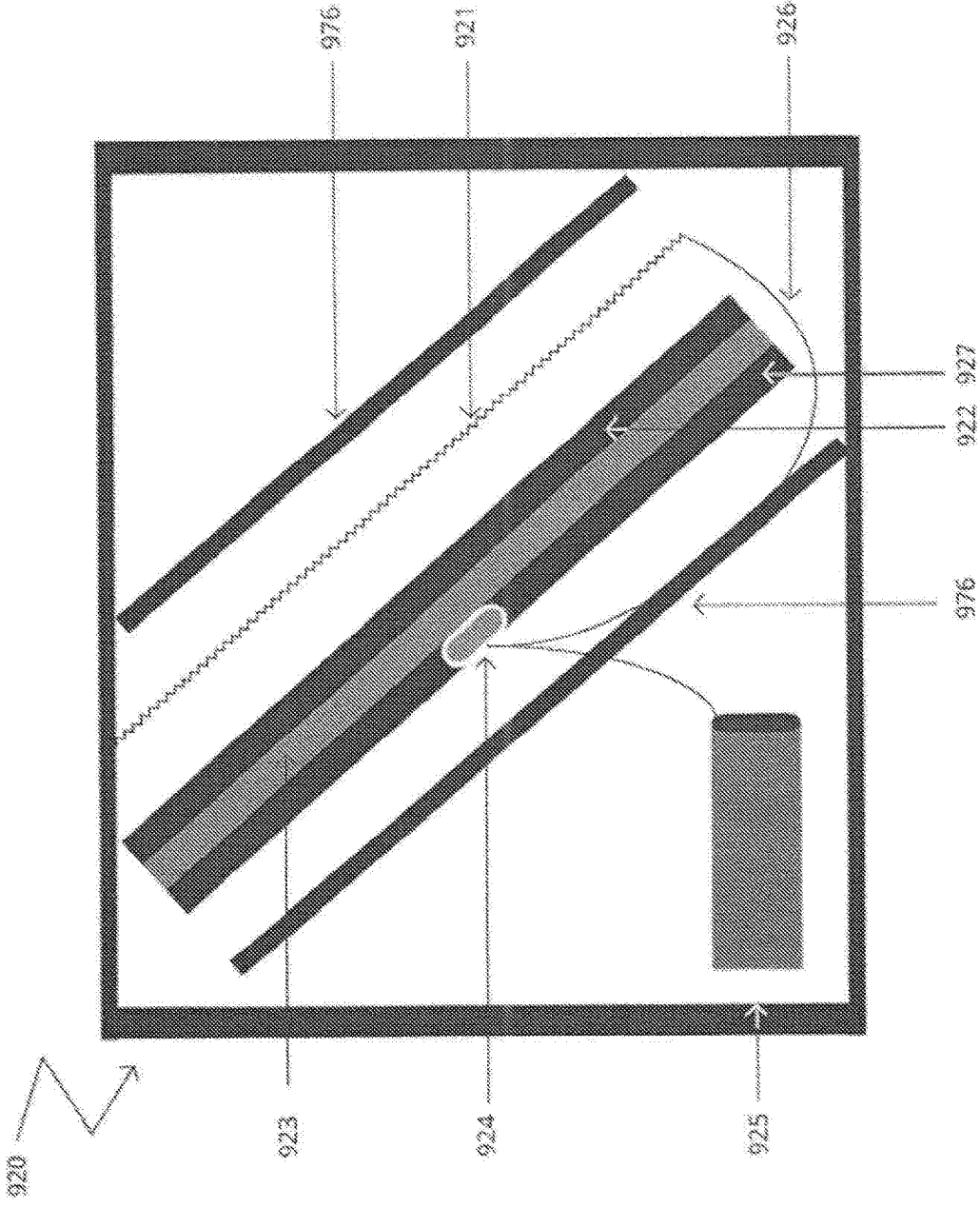

FIG 15E

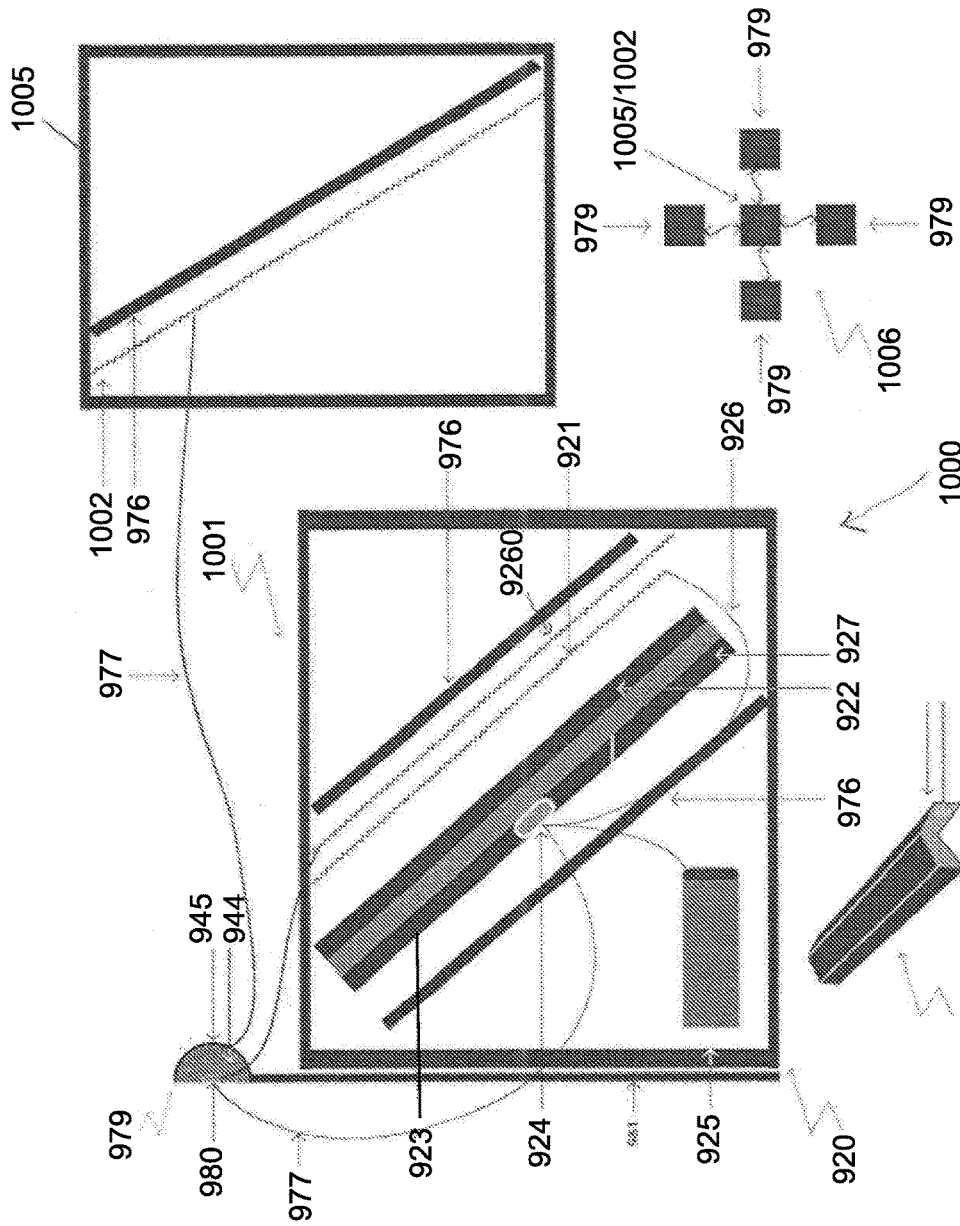

FIG 15H

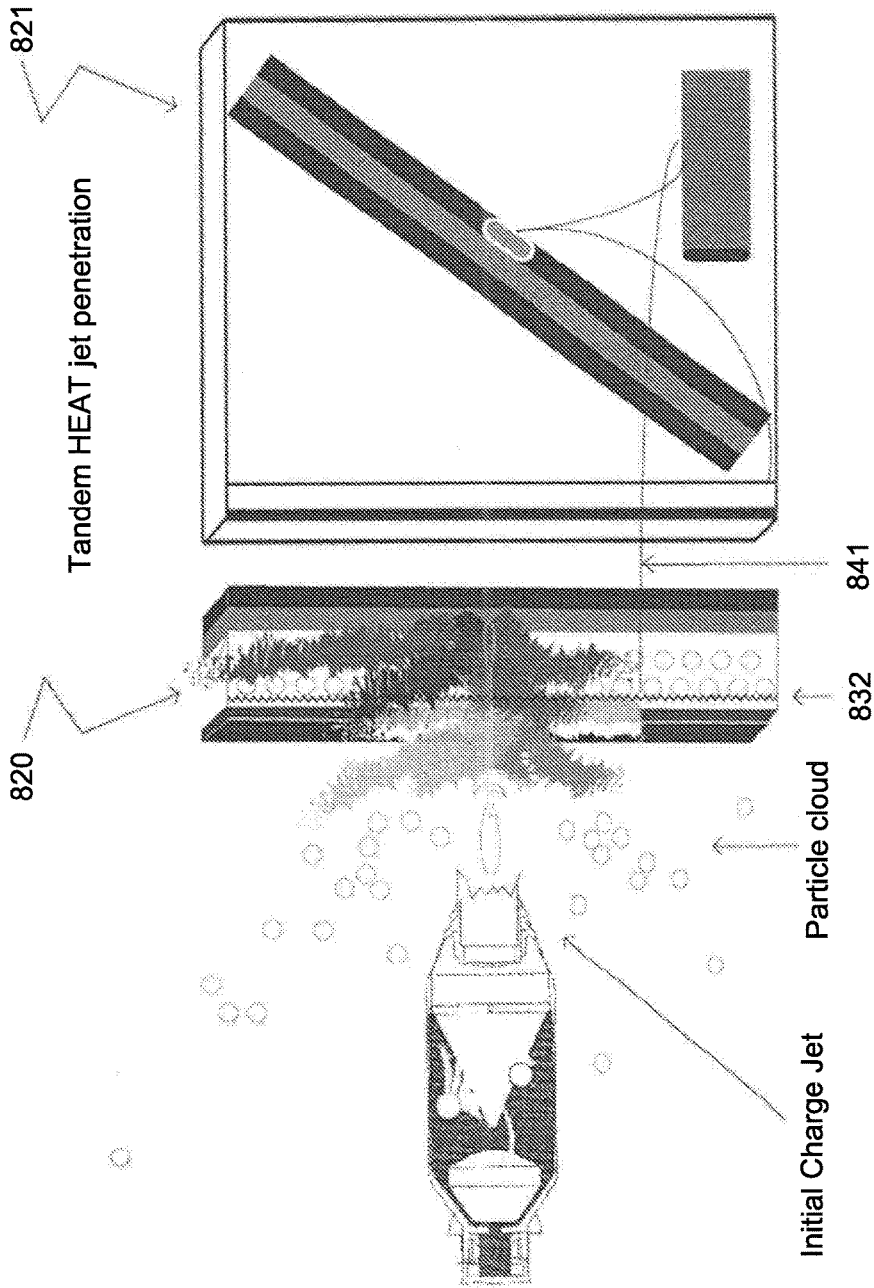

Fig. 16

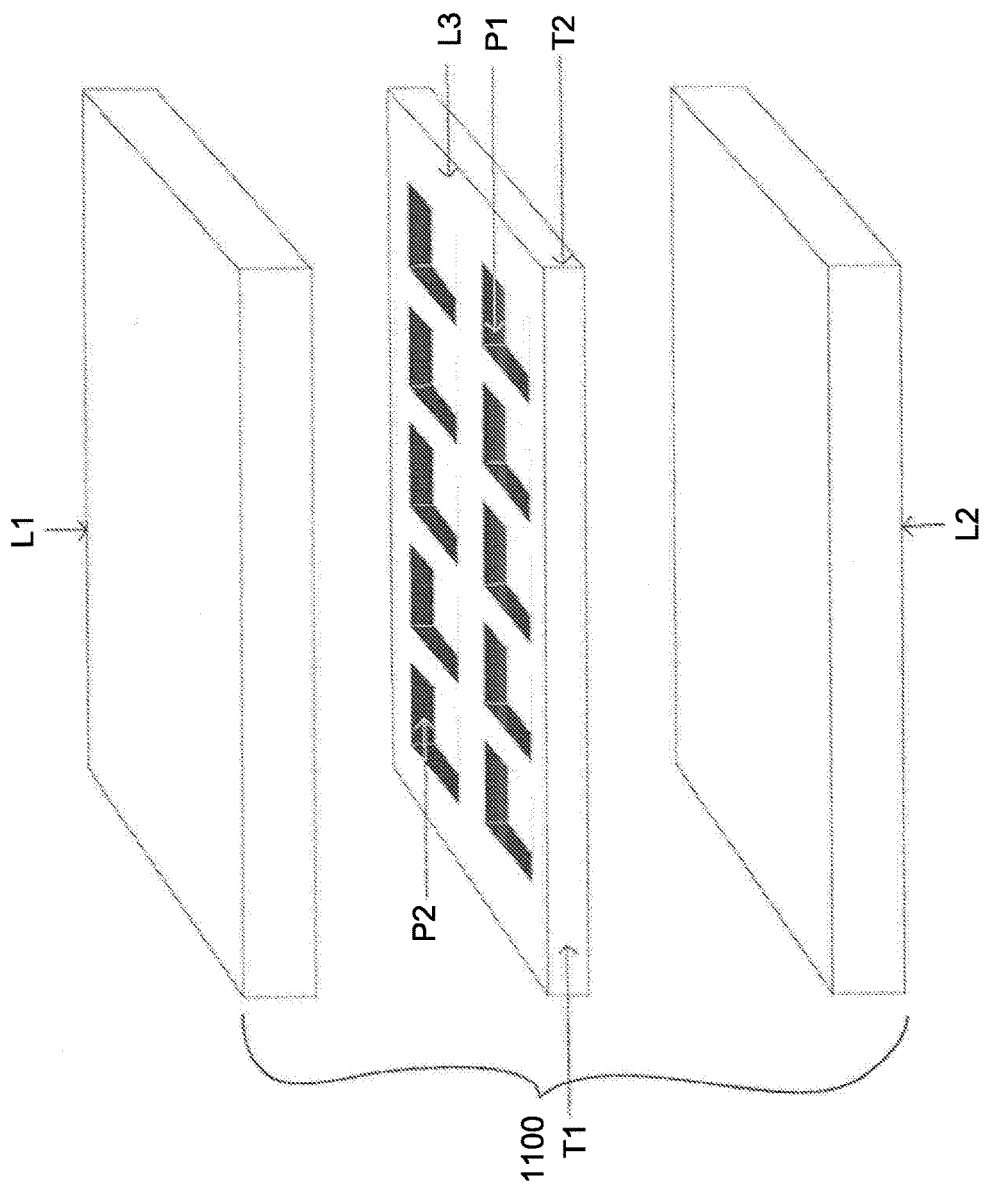

Fig. 17

REACTIVE ARMOR

FIELD OF THE INVENTION

[0001] The invention relates in general to the field of protecting armored vehicles or structures from approaching Kinetic Energy Penetrators (KEP) or rocket propelled HEAT warheads. More specifically, the invention relates to the protection of armored vehicles or structures from approaching Tandem warheads.

BACKGROUND OF THE INVENTION

[0002] Essentially HEAT (High Energy Anti-Tank) munitions operate by piercing the exterior armor of armored vehicle's, killing and maiming the crew inside, disabling vital mechanical systems, or both.

[0003] In order to enable an armored vehicle to sustain a shaped charge HEAT impact (hereinafter referred as HEAT), an external explosive element titled Explosive Reactive Armor (ERA), is attached to the vehicle's armor.

[0004] The standard ERA consists of sheets or a slab of high explosive, sandwiched between two plates, typically metal, called the reactive or the dynamic elements.

[0005] In one example, and in order to neutralize an incoming rocket propelled HEAT, such as RPG-7, and upon impact, the high explosive of the reactive armor detonates, forcibly driving the metal plates of the reactive armor apart, against a shaped charge jet. The projected plates disrupt the metallic jet penetrator.

[0006] In one prior art example, the notable efficiency of the ERA is primarily attributed to two fundamental mechanisms. First, the moving plates change the effective velocity and angle of impact of the shaped charge jet. The effect is to change the angle of incidence and thus reduce the integrity of the jet. In a second aspect, since the plates are angled compared to any likely impact direction of the shaped charge warhead, and as the plates move outwards usual, the impact point on the plate changes over time, requiring the jet to cut through fresh plate material. This second effect significantly increases the effective plate thickness during the impact.

[0007] The ERA has proven itself as highly efficient in defeating single stage rocket propelled HEAT-shaped charge warheads, such as the RPG 7, TOW, LOW, etc.

[0008] As soldiers rely heavily on the use of rocket propelled HEAT to defeat armored vehicles, a new warhead technology named Tandem-Charge has been developed to defeat the ERA. In essence, a Tandem-Charge weapon is an explosive device or projectile that comprises two or more stages of detonation. It is effective against reactive armor which is designed to protect an armored vehicle (mostly tanks) against anti-tank munitions.

[0009] The Tandem Charge comprises two or more detonation stages. The first detonation stage of the tandem-charge weapon is typically a weak charge that activates the ERA upon impact, so that the second warhead may pass unimpeded. Commonly, this may involve detonating the reactive armor before the main charge arrives, causing the timing of the counter-explosion to fail to disrupt the main charge which comes with the second detonation stage. The second detonation stage of the tandem-charge attacks the same location as the first detonation point of impact, which is where the reactive armor has been compromised. Since the reactive armor is the only element that enables the armored vehicle's integral armor to sustain an impact of a

HEAT jet, as the reactive armor was compromised by the first detonating stage, the main charge (second detonation) has an increased likelihood of penetrating the main armor of the vehicle.

[0010] It is therefore an object of the present invention to provide a reactive armor module that can defeat Tandem warheads.

[0011] It is another object of the present invention to improve and augment the susceptibility of existing reactive armor modules to sustain a Tandem warhead hit.

[0012] It is still another object of the present invention to provide the improved reactive armor in manner which is simple, of relatively light weight, and highly reliable.

SUMMARY OF THE INVENTION

[0013] According to an aspect of the present invention there is provided reactive armour comprising:

[0014] an explosive reactive armour module comprising a first triggering screen and an explosive layer; and

[0015] at least one explosive module placed in proximity to said reactive armour module and connected to said first triggering screen for detonation.

[0016] According to a second aspect of the present invention there is provided a reactive armour module comprising an explosive layer triggerable by an incoming projectile, said layer being shaped in order to provide a shear component of a blast against said incoming projectile.

[0017] According to a third aspect of the present invention there is provided a reactive armour module comprising a first extremity and a second extremity, first and second steel layers extending between said first extremity and said second extremity, said first and second steel layers being lined with respective explosive layers, a first explosive charge at said first extremity adjacent said first steel layer and a second explosive charge at said second extremity adjacent said second steel layer, and a trigger screen configured to detonate said first and second explosive charges in a timed manner in response to an incoming projectile in order to create a scissoring explosive effect.

[0018] In the various aspects, the module may comprise at least one layer of rigid particles, the particles arranged in relation to said plurality of explosive layers to form a particle cloud for disrupting an incoming jet following detonation of the explosive layer.

[0019] In the module, at least some of the rigid particles in the particle layer may comprise a rigid core surrounded by a relatively less rigid shell. In the module at least one of said explosive layers may comprise a shaped charge which may be an explosive lens.

[0020] The explosive layers may be unevenly distributed over the module, thereby to form a disruptive wavefront.

[0021] One of said explosive layers may comprise at least one shaped region comprising at least one cavity or at least one groove.

[0022] The module may comprise at least one layer of rigid particles, the particles arranged in relation to said plurality of explosive layers to form a particle cloud for disrupting an incoming jet following detonation of the explosive layer.

[0023] At least some of the rigid particles in the particle layer may comprise a rigid core surrounded by a relatively less rigid shell.

[0024] At least one of said explosive layers may comprise a shaped charge.

[0025] At least one of said explosive layers may comprise at least one explosive lens.

[0026] At least one of said explosive layers is unevenly distributed over said module, thereby to form a disruptive wavefront.

[0027] At least one of said explosive layers comprises at least one shaped region comprising at least one cavity or at least one groove.

[0028] The module may include at least one explosive layer which is shaped into a plurality of explosive lenses, the lenses being triggerable to provide a shear force against an incoming projectile.

[0029] The module may comprise a triggering screen for triggering said explosive layer or at least one of said explosive layers.

[0030] The screen may be divided into at least two triggering parts, each part triggered by a different approach angle of an incoming projectile and each part configured to initiate an explosion in a different part of said explosive layer.

[0031] At least one layer of rigid particles may be arranged in relation to said plurality of explosive layers so as to form a particle cloud for disrupting an incoming jet following detonation of the explosive layer.

[0032] At least some of the rigid particles in the particle layer may comprise a rigid core surrounded by a relatively less rigid shell.

[0033] At least one of said explosive layers may comprise a shaped charge.

[0034] At least one of said explosive layers may comprise at least one explosive lens.

[0035] At least one of said explosive layers may be unevenly distributed over the module, thereby to form a disruptive wave front.

[0036] At least one of the explosive layers may comprise at least one shaped region comprising at least one cavity or at least one groove.

[0037] An embodiment may comprise at least one explosive layer which is shaped into a plurality of explosive lenses, the lenses being triggerable to provide a shear force against an incoming projectile.

[0038] The module may comprise at least one explosive layer which is shaped into a plurality of explosive lenses, the lenses being triggerable to provide a shear force against an incoming projectile.

[0039] The module may comprise a triggering screen for triggering said explosive layer or at least one of said explosive layers.

[0040] The screen may be divided into at least two triggering parts, each part triggered by a different approach angle of an incoming projectile and each part configured to initiate an explosion in a different part of said explosive layer.

[0041] The module may detonate different explosive layers or different parts of respective explosive layers in a timed sequence or simultaneously.

[0042] The module may have a planar surface and may comprise at least one steel plate, the steel plate having at least one layer of high explosive attached thereto, the steel plate being angled with respect to said planar surface.

[0043] The module may include at least one explosive layer sandwiched on either side by steel plates.

[0044] The module may include two explosive layers, each sandwiched on either side by steel plates, one of said

layers being placed outwardly on said module and one of said layers being placed inwardly on said module, said outer layer comprising an explosive material with a detonation rate that is lower than a corresponding detonation rate of said inner layer.

[0045] The module may include a third explosive layer sandwiched on either side by steel plates, the third explosive layer being placed outwardly of both of said two explosive layers and having a detonation rate which is faster than both of said two explosive layers.

[0046] According to a fourth aspect of the present invention there is provided a reactive armour module comprising a plurality of explosive layers, each of said explosive layers being triggerable in response to an incoming projectile, each of said explosive layers being constructed from an explosive material having a different rate of detonation.

[0047] According to a fifth aspect of the present invention there is provided a reactive armour module comprising an explosive layer, the layer being shaped into a plurality of explosive lenses, the lenses being triggerable to provide a shear force against an incoming projectile.

[0048] The triggering screens may also be stacked one after the other and connected to a processing unit that can calculate the velocity of an incoming object by calculating the time elapsing between the activation of each of the triggering screens as to infer an event. Said mechanism might be used to augment triggering screens as described as to activate a blast sequence as described/

BRIEF DESCRIPTION OF THE DRAWINGS

[0049] In the drawings:

[0050] FIG. 1 illustrates the general structure of a HEAT-shaped charge Tandem warhead;

[0051] FIG. 2 illustrates in a cross-sectional form a typical reactive armor module;

[0052] FIG. 3 illustrates in a cross-sectional form a structure of a reactive armor module, according to an embodiment of the present invention; and

[0053] FIG. 4 describes the general manner of operation of a proposed reactive module 30;

[0054] FIG. 5 shows a general structure of a reactive module according to a proposed reactive armour module;

[0055] FIG. 6 shows still another embodiment of a reactive module 130, according to a proposed reactive armour module;

[0056] FIG. 7 shows still another reactive module according to a proposed reactive armour module;

[0057] FIG. 8 shows still another reactive module according to a proposed reactive armour module;

[0058] FIG. 9 shows a triggering screen which is used in an ERA according to an embodiment of the present invention;

[0059] FIG. 9A shows the embodiment of FIG. 2 provided with a triggering screen according to an embodiment of the present invention;

[0060] FIG. 9B shows the embodiment of FIG. 7 provided with a triggering screen according to an embodiment of the present invention;

[0061] FIG. 9C shows the embodiment of FIG. 8 provided with a triggering screen according to an embodiment of the present invention;

[0062] FIG. 9D shows an embodiment with a scissoring effect on the reactive explosion;

[0063] FIGS. 10-12 show still other previously proposed reactive armour modules not claimed herein;

[0064] FIG. 13 shows a reactive armour module with a shaped explosive liner to form a directed wavefront in more than one direction according to an embodiment of the present invention;

[0065] FIG. 15a shows a prior art structure of a reactive module;

[0066] FIGS. 15b-15f and 15h show various embodiments of the invention;

[0067] FIG. 16 shows still another embodiment of the invention; and

[0068] FIG. 17 shows still another embodiment of the invention.

DETAILED DESCRIPTION OF PREFERRED EMBODIMENTS

[0069] Reactive armour according to the present embodiments comprises an explosive reactive armour module comprising a first triggering screen and an explosive layer; and at least one explosive module placed in proximity to the reactive armour module and connected to said first triggering screen for detonation.

[0070] Irrespective of use of an explosive module, the reactive armour module may have shaped charges to produce a shaped wavefront, and the triggering screen may be divided into at least two triggering parts, each part triggered by a different approach angle of an incoming projectile and each part configured to initiate an explosion in a different part of the reactive armour module or in a different explosive module if provided.

[0071] FIG. 1 illustrates the general structure of a HEAT-shaped charge Tandem warhead 10. Warhead 10 comprises a tip 11, initial (first) charge 12, a first-stage fuse 13, a spacing rod 14, a main charge 15, and a second-stage (main-charge) fuse.

[0072] As noted above, upon impact with a typical reactive armor, the first charge of the Tandem warhead detonates, initiating a first jet, which activates the reactive armor charge. Thereafter, at a predetermined and precise timing, the second charge of the Tandem warhead detonates, initiating a second jet which penetrates the main body armor of the vehicle, at the location in the reactive module that was previously activated by the first charge.

[0073] A cross-section of a typical armor module 20 is shown in FIG. 2. The reactive armor module comprises a front plate 21, a back plate 22, and a high explosive charge 23 in between the two plates. As the, the notable efficiency of the reactive armor is primarily attributed to two fundamental mechanisms. First, the moving plates change the effective velocity and angle of impact of the shaped charge jet, changing the angle of incidence and reducing the integrity of the jet. In a second aspect, since the plates are angled compared to the usual impact direction of the shaped charge warhead, and as the plates move outwards, the impact point on the plate changes over time, requiring the jet to cut through fresh plate material, in fact increasing the effective plate thickness during the impact.

[0074] While the typical reactive armor has proven itself as highly efficient in defeating single stage rocket propelled HEAT-shaped charge warheads such as, the RPG 7, TOW, LOW, etc., it nevertheless fails in defeating Tandem warheads such as RPG-29.

[0075] FIG. 3 illustrates in a cross-section form a structure of a reactive armor module 30, according to an embodiment of the invention. Reactive armor 30 may be a stand-alone module, or may come as an add-on module to an existing reactive armor module. In the latter case, the armor 30 may come in front of the typical reactive armor module (20 in FIG. 2), or after module 20. In certain embodiments, a space may be provided between modules 30 and modules 20.

[0076] The module 30 of the present invention comprises a front plate 31, and a back plate 32. In one embodiment the plates are made of some rigid material such as steel, ballistic aluminum, Titanium, Alumina, etc., or some composition of the materials. In another embodiment, plates 31 and 32 are made of polymers or materials having similar characteristics, such as Dynema, Spectra, Aramid, etc. In still another embodiment, the plates may be made of a combination of polymers and rigid materials. In still another embodiment, the front and back plates, 31 and 32 respectively, may be made of different materials or different material combinations.

[0077] Module 30 further comprises two internal layers in between the front and back plates 31 and 32. The first of the two layers is a particle layer 33, and the second of the two layers is a high-explosive layer 34.

[0078] The particles layer 33 comprises a plurality of rigid particles. For example, the rigid particles may have a spherical shape, cylindrical shape, or shapes that are particularly designed to maximize the likelihood of ascertaining impact with the incoming Tandem warhead, and ascertaining penetration into the Tandem warhead. In some embodiments, a combination between various shapes may be used.

[0079] As shown in the inset, particle 3311 may have an iron core 3312 surrounded by a layer of lighter material 3313 and a shell 3314. The result is that the particles are spaced apart and do impede each other when explosive layer 34 is detonated.

[0080] FIG. 4 describes the general manner of operation of the reactive module 30 according to embodiments of the present invention. Two reactive armour plates 30 and 20 are positioned one in front of the other. Upon impact of a Tandem warhead 50 with the front plate 31 of the front reactive armour plate 30, the first fuse of the Tandem warhead initiates a blast, resulting in a jet which pierces the front plate. As the jet goes through the particle layer 33, it eventually impacts the high explosive layer 34, resulting in a blast of the layer, that ejects the particles towards the main (second) charge of the Tandem warhead 50. These particles are ejected towards the incoming second portion of the Tandem warhead, impacting it at a very high speed before the blast of the second portion of the second warhead is initiated. The impact of the metallic particles, that travel at a very high speed damages the integrity of the second portion of the Tandem warhead, severely impairing its ability to form a cohesive and focused jet. In some cases, the high number of particles may hit the second portion rendering it useless altogether, even without allowing its main charge to detonate.

[0081] The reactive armour layer 30 may include a triggering screen, allowing for control of the timing of the detonation, as will be described in greater detail hereinbelow.

[0082] In one embodiment, the particles are spaced apart to reduce the kinetic energy transfer between the particles that is caused by the mechanical impact that the jet causes.

The separation between the particles may be achieved by coating each particle with a softer material, for example aluminum or a polymer or a puffed energy absorbing material, as discussed above with respect to FIG. 3 and particle 3311. Alternatively, energy absorbing elements may be provided between the particles. In still another alternative, the high explosive charge may be mixed between the particles. In still another embodiment, a back layer of high explosive charge is provided, in addition to mixing charge between the particles. In still another embodiment, an additional layer of explosive may be provided between the particles layer and the front plate. In still another embodiment, a rigid or composite material layer may be placed between the particles and the high explosive layer to prevent damage to the high explosive layer by the kinetic impact of the jet on the metallic particles that might damage the explosive charge.

[0083] In still another embodiment, the cross-section structure of the casing may be designed to channel the energy of the blast to achieve a desired particles cloud vector and shape. For example, the high explosive is shaped in a curved manner, or is placed in a sloped or curved casing, and some examples are given below. In still another alternative, a rigid material might be placed on a part of the shaped explosive creating a time-gap explosion between outgoing particles. In another aspect, geometric elements such as a pyramid shaped element is inserted in between the particles with its tip towards the explosive layer to effect upon detonation the blast effect on the particles vector.

[0084] The reactive module 30 of the present embodiments may also comprise an additional front layer in front of the front plate 31. Such additional front layer may be used as a triggering mechanism that upon impact with the Tandem warhead will activate the reactive armor module either by an electronic signaling or by a sequential blast caused by explosive material which is attached to the additional plate.

[0085] In still another embodiment, a proximity fuse or sensor may be associated with one or more reactive armor modules 30, in to activate the detonation before the impact of the Tandem warhead with the front plate.

[0086] FIG. 5 shows a general structure of a reactive module according to still another embodiment. In contrast with the previous embodiments, the reactive module of FIG. 5 is designed to harness an effect know in the art as implosion wherein the blast of the reactive module is directed along the direction of the incoming HEAT jet wherein the blast wave is directed into a body of rigid particles that are arranged in a predetermined structure causing the structure to collapse into itself as the rigid particles that formed the structure change their relative position with respect to each other in a dynamic form applying a plurality of multidirectional kinetic impacts on the incoming jet, deforming it by subjecting it to a multitude of interactions with the moving particles, wherein the impact angle, velocity, surface face etc. of each particle affect the HEAT jet not only as it forms, but also in its initial penetration phase, as well as a continuous impacting on the HEAT jet tail, as the implosion residual blast energy causes the particles to continue their damaging motion, even after the initial impact. The reactive module 130 comprises a front plate 131, a back plate 132, a front explosive layer 134, which is attached to the rear surface of the front plate 131, and a particles layer 133. The explosive layer 134 of this embodiment covers substantially the entire area of the rear

surface of the front plate 131. Upon impact of the HEAT charge, the explosive layer 134 is initiated as to create an explosion that causes the structure of the rigid particles to collapse into itself, imploding as discussed above, and effectively damaging the jet by causing the particles to exert high kinetic energy on the jet from multitude of directions, effectively destroying the jet.

[0087] FIG. 6 shows still another embodiment of a reactive module 130, according to an embodiment of the present invention. The reactive module 130 comprises a front plate 131, a back plate 132, a front explosive layer 134, which is attached to the rear surface of the front plate 131, and a particles layer 133. The explosive layer 134 of this embodiment covers substantially the entire area of the rear surface of the front plate 131, and it also has an extension 141, along a side plate of the reactive module. Upon impact of the HEAT charge, the explosive layer is initiated as to create an explosion that causes the rigid particles to eject in accordance with the blast wave. As the blast wave originates from an asymmetric explosive layer geometry the blast wave does not have a clear trajectory. Rather blast waves from each surface may cause the particles to move in more than one direction, exposing the incoming HEAT jet to a multitude of kinetic forces, effectively damaging the jet. Optionally, the explosive geometry varies as to create a multitude of shock wave epicenters, ejecting the particles causing them to exert high kinetic energy on the jet from a multitude of directions, effectively destroying the jet. Furthermore, focusing of the shock wave generated by an explosion may be directed and/or amplified by means of shaping the explosive by creating a geometrical structure in the explosive as to achieve a directional blast wave in a manner known in the art as the Monroe effect. Blast lens 140 is shaped to direct and amplify the shock wave in a given direction, as to catapult the particles in a collision course with the jet or with other particles as to generate a secondary impact on particles that in turn will affect the jet. In an embodiment, some of the blast is focused by the blast lens and some is not. This effect may be enhanced by insertig a liner to within the explosive lens 140. In an alternative embodiment the functionality of the explosive lens may be arranged to disperse the shock wave as to direct the rigid particles trajectory to a desired course.

[0088] FIG. 7 shows still another embodiment of the present invention. While the explosive layer extension 141 of FIG. 6 covers one side surface entirely, the extension 141a covers only a portion thereof. Moreover, while in the embodiment of FIG. 6 there is only one extension 141, the embodiment of FIG. 7 comprises a second extension 141b, which is located in this example at the opposite corner of the reactive armor module 130. The extension 141b may cover the side surface entirely. Preferably, the two extensions 141a and 141b are positioned on different axes, as shown. Upon impact of the HEAT charge, the explosive layer is initiated as to create an explosion that causes the rigid particles to eject in accordance to the blast wave. As the blast wave has more than one epicenter (as a result of the asymmetric explosive layer geometry in this embodiment), the blast wave from each surface may cause the particles to move in plurality of directions in a sequential manner, as upon impact, the incoming HEAT jet causes the explosive charge 134 to detonate. As the detonation point can either be close to extension 141a or extension 141b, the explosion may arrive at one of the extensions earlier than the other. Dif-

ferent types of explosives might be used in extensions **141a** and **141b** to ensure that the explosions are non-simultaneous. Furthermore, the two extensions do not face one another exactly, as to prevent reduction of the blast yield effects. In another embodiment, rigid particles adjacent sides **141a** and **141b** respectively have one or more of: different mass, different shape, different structural alignment. Furthermore, the rigid particles may be embedded in materials of different densities and particle arrangement, material tensile strengths etc. A multitude of kinetic forces that are formed due to the asymmetric arrangement effectively damage the jet. Also in this embodiment, and in similarity to FIG. 6, the explosive geometry may vary as to create a multitude of shock wave epicenters, ejecting the particles causing them to exert high kinetic energy on the jet from more than one direction, effectively destroying the jet. Furthermore, focusing of the shock wave generated by an explosion may be directed and/or amplified by means of shaping the explosive by creating a geometrical structure in the explosive as to achieve a directional blast wave in a manner known in the art as Monroe effect. Blast lens **140** (shown in FIG. 6) may be incorporated also in one or more location of the explosive layers as to shape, direct, and amplify the shock waves in given directions, as to catapult the particles in a collision course with the jet or with other particles as to generate a secondary impact on particles that in turn will affect the jet. This effect may be enhanced by inserting a liner to within the explosive lens **140**. In an alternative embodiment the explosive lens functionality may be converted as to disperse the shock wave as to effect the rigid particles trajectory to a desired course.

[0089] FIG. 8 illustrates a three layer structure reactive module according to still another embodiment of the invention. It is to be noted that the three layers are merely an example and further layers may be added to make further embodiments. The reactive module **230** comprises a strike and back faces **231** and **232**, respectively, first explosive layer **234**, second explosive layer **235** third explosive layer **236**, and fourth explosive layer **237**. A first steel wall **246** with apertures **246a**, **246b**, and **246c** separates between the first and second explosive layers **234** and **235**, respectively. Explosive layers **234**, **235**, **236** and **237** may be made of a single relatively fast reacting explosive material. A first particle and explosive structure **233a** is arranged between the strike face and the first steel wall **246**, behind which is located second particle and explosive structure **233b**. A separator **239** separates between the second particle and explosive structure **233b** and third particle and explosive structure **233c**. Structure **233a** may be made up of an explosive which is slower than that of layers **234-237**. Structure **233b** may be made of an explosive which is slower still and structure **233c** may be made of an explosive which is slower than all the others. Upon impact with a HEAT jet, the explosive layer **234** explodes, ejecting rigid particles in various directions, thereby disrupting the main charge of the incoming warhead.

[0090] The progress of the explosion among the layers is not clearly defined and several paths are possible. For example the explosion may initiate within the first particles structure **233a**, the blast propagating via the apertures **246** activating the main explosive layer **235**, causing an immediate explosion of the second explosive layer **235**. As the second explosive layer **235** is detonated, an implosion process as described above in detail begins, within the

particle structure **233b**, that collapses into itself. Following this explosion, the blast propagates via the explosive layer **236**, to begin a blast sequence of the explosive layer **237**. The detonation of the explosive layer **237** causes the particles structure **233c** to collapse into itself, as the particle mass collides with the collapsed particles structure **233b**. This multiple explosion-structure implosion tandem process damages the incoming HEAT jet. More specifically, multiple kinetic force vectors that are formed due to the asymmetric arrangement effectively damage the jet. Also in this embodiment, and in similarity to FIG. 6, the explosive geometry may vary as to create a multitude of shock waves, ejecting the particles causing them to exert high kinetic energy on the jet from two or more directions, effectively destroying the jet. Furthermore, focusing of the shock wave generated by an explosion may be directed and/or amplified by means of shaping the explosive by creating a geometrical structure in the explosive as to achieve a directional blast wave in a manner known in the art as Monroe effect. Blast lens **140** (shown in FIG. 6) may be incorporated also in one or more location of the explosive layers as to shape, direct, and amplify the shock waves in given directions, as to catapult the particles in a collision course with the jet or with other particles as to generate a secondary impact on particles that in turn will affect the jet. This effect may be enhanced by inserting a liner to within the explosive lens **140**. In an alternative embodiment the explosive lens functionality may be converted as to disperse the shock wave as to effect the rigid particles trajectory to a desired course. It should also be noted that the inclusion of apertures within the steel plates or separator is optional. This example is non-limiting, as additional separators lenses, or steel plates may be used to shield, one or more explosive layer, thereby to prevent corruption of explosive layers, prematurely. Furthermore, it must be noted that in order to augment the steel plates, as described, materials such as alumina **98**, silicone carbide, etc. may be used as part of this reactive module, as well as a plurality of various materials as polymers as well as hollow structures with multitude of geometries may be used to direct, magnify, reduce, etc. blast induced forces, and physical and mechanical effects that may affect the end result of the modules, as described above. It must be noted that use of the reactive modules of the invention may be executed as a stand-alone module, or in combination with other modules, either those described herein, or those known from the prior art.

[0091] It should be noted that the typical reactive armor is generally mounted slanted relative to vertical orientation (although this general situation is not shown FIGS. 2 and 4).

[0092] In still another embodiment of the present invention, a triggering screen is provided in order to enable timed initiation of the blast sequence in the ERA of the invention. Triggering screens are known in the art. For example, a triggering screen model no. PT-0303500600MK is manufactured by Whithner Corporation (a US company), and is shown in FIG. 9. The triggering screen is typically used to close an electrical circuit upon its penetration. Upon penetration into the triggering screen, an electrical circuit is closed, and a detonation circuit is initiated, detonating the explosive in the charge. The triggering screen may alternatively be based on piezoelectric elements which produce a current in the event of pressure due to an explosive event, or the detonator may be operated based on detection of an electromagnetic field. In all places herein where a triggering

screen is mentioned, it will be appreciated that any other means which provide blast timing or sequencing control are included. The latency in the blast sequence can be managed by means known in the art as to allow the blast sequence to begin, for example, 5 microseconds from the time of piercing of the triggering screen to 20 microseconds from the time of piercing. The distance of the triggering screen from the explosive layer 134 or any other part deemed as significant in the charge is a key factor in allowing the management of the blast prior to the impact by the jet. As shown in FIGS. 9 to 9C, a triggering screen 241 is used in order to time the blast of the high explosive layer 134. According to the present embodiments, such a triggering screen 241 is mounted behind the strike face. The distance of the triggering screen 241 from the explosive layer 134 can be adjusted to determine the maximal amount of time that a blast sequence can be initiated in the charge prior to the jet impact with elements within the ERA of FIG. 9B. In FIG. 9C, the screen is positioned, for example, within the elements that compose the charge. As the jet moves through the elements that compose the charge, it triggers a blast sequence prior to the jet arrival to a designated location within the charge.

[0093] It should be noted that such a technique may also be used to trigger the prior art ERA module 20 (of FIG. 2) causing it to explode before the shaped charge jet impacts the front steel plate that sandwiches the high explosive. It should also be noted that utilizing the triggering mechanism using the triggering screen 241 (as shown in FIG. 9a), can dramatically improve the likelihood of the ERA module of FIG. 2 to defeat the jet. FIG. 9a shows a screen 241 which is positioned some distance in front of the front plate 21 of the ERA 20. The detonators are indicated in FIGS. 9a, 9b and 9c as numeral 243. The blast circuits are not shown in the figures for the sake of brevity, as they are conventional.

[0094] It should also be noted that the triggering screen 241 discussed above may be augmented or replaced by other means known in the art to generate a blast sequence before the impact of the incoming jet and predetermined elements in the ERA.

[0095] As shown in FIG. 9, the triggering screen 241 may be divided into two or more separate screens 241a and 241b. Whichever of divided triggering screens is operated first may initiate detonation from a particular location on the reactive armour. Thus missile strikes from different directions may be defended against by different blast wave vectors.

[0096] Reference is now made in greater detail to FIG. 9a shows in a cross-sectional form a typical reactive armor module to which is added the triggering screen 241 as discussed above for triggering detonator 243 to detonate the explosive layer 21. The triggering screen 241 is located a predetermined distance behind the strike face 2410 in space 2412. Space 2412 is of a predetermined size and located between strike plate 2410 and steel front plate 21. The steel front plate 21 is located in front of explosive layer 23 which in turn is placed in front of rear steel plate 22.

[0097] The space may be of any size and may be empty or may be filled, say with polymer. As discussed, the screen 241 is connected to detonator 243 and the distances are configured to detonate the explosive layer 23 at a precise predetermined time after the triggering screen is activated, as discussed.

[0098] FIG. 9b shows in a cross-sectional form reactive armor module according to FIG. 7, to which is added a

triggering screen according to the present embodiments. The triggering screen 241 is located a predetermined distance behind the strike face 2410 in space 2412. Space 2412 is of a predetermined size and located between strike plate 2410 and steel front plate 21. The steel front plate 21 is located in front of explosive layer 23 which in turn is placed in front of rear steel plate 22.

[0099] The space may be of any size and may be empty or may be filled, say with polymer. As discussed, the screen 241 is connected to detonator 243 and the distances are configured to detonate the explosive layer 23 at a precise predetermined time after the triggering screen is activated, as discussed. Extensions 141a and 141b together with the general distribution of the explosives, ensure that the explosion wavefront is highly disruptive.

[0100] FIG. 9c shows in a cross-sectional form reactive armor module according to FIG. 8, which is provided with a triggering screen according to the present embodiments. The triggering screen 241 is located a predetermined distance behind the strike face 2410 in space 2412. Space 2412 is of a predetermined size and located between strike plate 2410 and steel front plate 246 and contains first explosive layer 233a. The steel front plate 246 has apertures 246a, 246b 246c and is located in front of explosive layer 233b and 233c which in turn is placed in front of rear steel plate 22.

[0101] The space 2412 may be of any size. As discussed, the screen 241 is connected to detonator 243 and the distances are configured to detonate the explosive layers 233a, 233b and 233c in a precisely timed sequence after the triggering screen is activated in order to provide a disruptive wavefront.

[0102] Reference is now made to FIG. 9D which shows that the particles of FIG. 9b are replaced by layers of steel, one on top of the other. Each layer of steel is backed by a layer of explosive. Two charges at either side of the module are detonated and cause a scissoring effect.

[0103] FIG. 10 discloses still another embodiment of the invention. In this embodiment, the explosive layer 234 is formed and molded somewhat slanted with respect to either the horizontal or the vertical plane. In the arrangement of the reactive armor charge, upon explosion, the particle structure 233 is ejected towards the incoming HEAT jet impacting it while applying an angular directed shear force on the jet 277. In still another embodiment shown in FIG. 11, the reactive armor comprises, in addition to the slanted explosive layer 234, a triggering screen 241 for activating the detonation sequence via wiring 278, resulting in the explosion of detonator 243, as discussed above. The triggering screen may be used for the closure of an electric circuit in order to generate an electromagnetic or an RF signal to be received by a suitable receiver, which may in turn initiate a blast sequence that may activate the detonator 243. In yet another embodiment the triggering screen, or any other device that may initiate the blast sequence, may be connected to more than one reactive armor module. Alternatively, the triggering screen may be divided, as discussed in respect of FIG. 9, so that different triggering sequences are carried out within the reactive armour unit depending on the direction of the incoming projectile.

[0104] The triggering screen, as shown, for example in FIG. 11, may operate with any of the embodiments described above. Voltage to the screen, to the switching mechanism, or to the detonation element may be obtained from: (a) a battery; (b) a capacitor; (c) an induction type

circuit; (d) a electromechanical element, that via the rocking motion causes a pendulum type element in a manner known in the art to move within an electromagnetic field, thereby to generate electricity, the electricity to be fed into a capacitor, battery etc.; (e) a piezoelectric element that upon pressure or impact by the HEAT jet generates electricity that may be directed into the triggering screen. Alternatively, the voltage which is generated by the piezoelectric element may activate a switching mechanism that may release stored energy in a capacitor or battery to activate the explosive sequence; (f) the use of chemicals or metals known in the art that upon contact (that is initiated by the HEAT explosion) generate electricity necessary to operate the abovementioned.

[0105] The above means (b), (e), and (f) may be used in conjunction with the triggering screen or as a triggering mechanism for the reactive armor as described in any of the abovementioned embodiments. They may also replace the triggering screen, as upon impact, they may release the voltage necessary to initiate the blast sequence. Preferably, the elements (b), (e), and (f) are placed at some distance in front of the explosive charge.

[0106] FIG. 12 illustrates reactive armor that comprises two steel plates 160 and 161 sandwiching a high explosive layer 162. The high explosive charge is fitted with a detonator 163 that is activated by the triggering screen 164 when activated as described in length above. Upon piercing the triggering screen, and prior to initiating any contact with the high explosive 162 sandwiched in between the steel plates 160 and 161, a blast is initiated by the triggering screen mechanism, causing the high explosive to explode and eject one or more of the metal plates towards the incoming jet 165 prior to its impact with the reactive armor sandwich. The triggering screen is behind the strike face 166 as to prevent accidental activation by elements other than the HEAT jet. The explosive is at an angle to the strike face, and may cause a blast at an angle to the incoming jet to defeat the integrity of the incoming jet.

[0107] Battery 167 may provide power to operate detonator 163.

[0108] It should be noted that the strike face 166 of all and any of the above reactive armor modules can be composed of rigid metallic elements such as steel, titanium, ballistic aluminum, and all types of metallic alloys. Furthermore, the strike face may be composed of rigid materials as alumina, boron carbide, etc. Furthermore the strike face may be composed of an assortment of polymers such as, aramid, dynema, etc. Furthermore, the strike face may be composed of compressed fibers, such as glass, carbon-fiber, etc. Each and any of the above materials may be combined or replace the strike face as described in the drawings that have been indicated as steel. The same applies to all other layers indicated herein as being steel layers.

[0109] FIG. 13 illustrates still another embodiment of the invention. Parts that are the same as in FIG. 12 are given the same reference numerals and are not described again except as required for an understanding of the present embodiment. Explosive layer 170 comprises one or more shaped explosive lenses 171 which are designed to cause disruptive wavefronts against the incoming jet 165. The lenses may be provided with or without a liner 172 (as known in the art). The liner may be copper or similar material, in order not to absorb too much of the energy of the explosion. The explosive lenses may be provided in various configurations, such as configurations 173 and 174 for different directions of

impact. A reactive armour module constructed using the explosive lenses may be used to defeat incoming HEAT jet 165 by activating the lenses using the triggering screen 164. In one embodiment, different parts of the module have different shapes of lenses, and in a further embodiment, the different parts may be operated by different parts of the triggering screen so that impacts from different directions are met with suitably directed blast waves.

[0110] In order to better direct the blast wave, the shape of the lenses in cross section may be triangular (as shown in the figure), spherical, or any other shape. In an alternative embodiment, the lens may be a part sphere with grooves or cavities. The grooves may be filled with liner. The grooves or cavities cause concentration of force and thus enhance the lensing effect.

[0111] FIG. 14 illustrates a combination of a particle based explosive reactive armor module 720 and an explosive reactive armor module 721 as described in FIG. 12. Parts that are the same as in FIG. 12 are given the same reference numerals and are not described again except as required for an understanding of the present embodiment. In each of the reactive armor modules 720 and 721 a triggering screen 164 is provided. Any of the two triggering screens may activate the reactive modules, in a timed blast sequence. Incoming tandem projectile 722 produces initial jet 723. The initial jet triggers screen 164 of first module 720 and the resulting explosion causes particle cloud 724 to form to disrupt the larger jet of the main detonation of projectile 722. Module 721 lies behind module 720 still untriggered, but would be triggered if the incoming projectile 722 overwhelms the module 720. Alternatively, module 721 is left in reserve for a further tandem projectile strike on the same location.

[0112] In all the embodiments herein, the modules may operate in a sequential order such as in a tandem setting for example, as they are arranged either one in front of the other or one besides the other or in clusters that comprise of several reactive armor modules. Each module may contain its own triggering mechanism as described or may be activated by a single triggering mechanism. A triggering screen, associated with one reactive armor module may upon activation initiate a blast sequence in another module as to operate in tandem as described.

[0113] In yet another embodiment, in order to assure the likelihood of destruction or severe deformation of the HEAT jet, a plurality of reactive armor modules as described in this application or known in the art are arranged in a sequential manner, i.e., one in front of the other, one above the other, one besides the other, etc., to be activated in a timed manner. One or more reactive armor modules known in the art, such as, explosive reactive armor, inert reactive armor, etc. As shown in a non-limiting example of FIG. 15a, an explosive reactive armor module 900 which comprises a steel layer 901, high explosive layer 902, and a steel layer 903, is placed in front of a module of FIG. 15b. In a non-limiting example, the module 920 of FIG. 15b comprises a triggering screen 921, steel layer 922, high explosive layer 923, detonator 924, energy source 925, wiring 926, and a steel layer 927 as described in details in this application. FIG. 15c shows a combined arrangement 930 between the reactive modules 900 of FIG. 15a and the reactive module 920 of FIG. 15b with fillers 952, 953, and 954 in between. The fillers are used to support the reactive modules within their common casing, and/or allows deceleration or acceleration of the steel plates of modules 900 and 920, as well as

containing of dissipating residual blast energy. The fillers may be made of: polymers of different densities, such as high density, low density Styrofoam, or any material that can be molded as to provide mechanical support either by alternating its areal density via inserting cavities to the material and/or via constructing mechanical structure that can support mass such as honeycomb, as well as by inserting energy absorbing materials such as fluids into the materials as well as containing the fluids such as water, in a container which is placed in the gaps **952**, **953**, and **954**. In addition, the fillers may be made of composites comprising of metal with different areal densities, as may be manufactured by pumping gas to create a rigid material based Styrofoam and the like. Furthermore, by using different masses of steel plates within each of the modules **900** and **920**, the interaction between the residual effects of the explosions of the modules is modified as to comply with a predetermined collision pattern between the blast wave and the steel elements. For example, if steel plates **922** and **927** of module **920** have a different mass, the plates may fly in opposite directions and/or at different speeds impacting the HEAT jet at a higher or lower speed, as deemed necessary, as well as interacting with the residual effects of the blast of module **900**. Upon impact, the tip of the HEAT jet **940** causes the modules **900** and **920** to explode. In order to optimize the overall efficiency of the module **930**, the following parameters may be regulated: (a) the distance between modules **900** and **920**, (b) the relative angle between the modules **900** and **920**; (c) the material and mechanical merits of fillers **952**, **953**, and **954**; (d) the technical merits of the high explosive used, its weight (density per module) and the use of different explosives with different mass in each of the modules **900** and **920**; (e) technical merits of the detonator as well as the placement of multiple detonators in a single module as shown in FIG. **15d**; (f) use of a detonating cord merits when a detonating cord is used to allow the initiation of the blast. The technical merits of the explosive may include the detonation speed of the explosive. For example the layer **900** may be the slowest layer. Layer **920** may be a faster layer and may for example be operated using a triggering screen. A third layer may be added in front, in the direction of the incoming projectile, and then the additional layer may be an extra-fast layer and may be operated by a triggering screen. Other suitable combinations may be used. While in FIG. **15b** a single detonator **924** is used, FIG. **15d** shows an embodiment where several detonators are used in module **920**. More specifically FIG. **15d** shows in top view an array of multiple detonators **924a-924n**. When a detonator **924** is activated, as in FIG. **15b**, a given amount of time elapses from the time of blast initiation until the full mass of high explosive is exhausted. As to minimize and expedite the time the total high explosive mass **923** (in FIG. **15b**) is blasted, multiple detonators may be distributed within the high explosive mass and may be activated simultaneously in order to provide a more uniform detonation, or in a sequence to provide a detonation shaped say for a particular direction. Such use of multiple detonators may be applied in all the various embodiments of the invention.

[0114] Currently, steel is used in reactive armor modules as the energy exerted by the HEAT jet on the steel plates is such that a replacement of steel with metal alloys as Titanium makes almost no difference in the overall performance of the reactive module as in FIG. **15a**. That is to say the same thickness is required. In the embodiment of the present

invention as shown in FIG. **15b** steel may be replaced by lower density materials such as Titanium and Aluminum alloys. The use of Ballistic Aluminum and Titanium alloys has yielded significantly better performance as a high volume of material can be ejected towards the incoming HEAT jet. The interaction between a high speed thicker moving plate and the incoming jet is proven to be highly efficient, to the point that an equivalent mass of Titanium that is ejected at an incoming HEAT jet can prevent the jet from penetrating a steel target at an efficiency rate of 250%, in comparison to a reactive armor module using the same mass of steel. Furthermore, when comparing the reactive module of FIG. **15a** with the reactive module of FIG. **15b**, using the same amount of high explosive and Ballistic Aluminum and Titanium alloys, the use of Ballistic Aluminum and Titanium alloys yielded significantly better performance (150%) in preventing the jet from penetrating a steel target at an efficiency rate of 150%.

[0115] FIG. **16** shows an example for two reactive modules **820** and **821**. A single triggering screen **832** is used for triggering a timed blast sequence that activates the two reactive modules **820** and **821**, that are arranged one in front of the other. The modules may be separated by a space as shown or may be in contact. The triggering screen activates both the reactive armor **820** in which it is contained and the reactive armor **821** to which it is connected by connection **841**. The connection **841** may relate to either wired connection, induction, RF, or any other connection means known in the art. In yet another embodiment, the screen **832**, while being contained within reactive module **820**, may activate only the other reactive module **821**. In that case, the reactive module **820** is activated by the impact of the HEAT jet. In yet another embodiment, module **820** may contain only high explosive, without particles. The above description of FIG. **16** exemplifies and applies to any combination of the reactive modules mentioned in this application or known in the art, *mutatis mutandis*.

[0116] In yet another embodiment a timed blast sequence as mentioned above, can be achieved by usage of timing means known in the art. In a further embodiment, usage of detonators having a different reaction time as to initiate a timed blast sequence from a single triggering element.

[0117] It should also be noted that, in an embodiment of the invention shown in FIG. **15e**, one or more sheets of metal **976** may be placed in front (i.e., in front of the triggering screen) and/or behind of the module of FIG. **15b**, or any other module of the invention, wherein the residual blast energy is used to eject the plates towards the incoming or outgoing HEAT jet, respectively.

[0118] In yet another non-limiting embodiment which is shown in FIG. **15f**, an explosive module **979** which comprises explosive charge **944**, detonator **980**, energy source **925**, and connecting wire **977** is provided. Module **979** is placed in proximity to NERA modules or ERA modules known in the art. The module **979** is associated with a triggering mechanism known in the art or as described above as to be activated by an incoming HEAT jet, in conjunction with the activation of the ERA/NERA. The module **979** detonates upon piercing of the triggering mechanism by the first jet to produce a blast wave which may destroy the incoming main warhead. More than one of module **979** may be placed in proximity to any given reactive armour module. The explosive may be mixed with rigid particles or may be

shaped in lenses as discussed hereinabove, and may include cavities or grooves as in previous embodiments.

[0119] Explosive module 979 may contain rigid elements that may be placed around the explosive charge 944. Explosive module 979 may be encased by a rigid casing 945.

[0120] In yet another non-limiting embodiment which is also shown in FIG. 15, an explosive module 979 is placed in proximity to module 920. The explosive charge is to be detonated in conjunction with the activation of the entire module, wherein detonator 980 is activated by the triggering mechanism 921, via communication element, such as wire, 977. The blast of explosive charge 944 can be timed via the usage of a detonator having a slower response time. The entire unit 979 may be attached in an elevated position with respect to module 920, or placed on top of it or beside it or in any other suitable position. Unit 979 is intended to destroy the main body of a tandem charge, such as the RPG29. The blasting unit may be covered by a protective shield, made of bullet proof material, as to avoid damage to the charge. In the event that a rigid casing 945 made of metal or any of the previously listed alternatives is used to cover the charge, the internal part of the cover may be grooved as to allow a quick release of the explosive energy through the case. In another embodiment, the explosive material is molded in a manner known in the art into a structure made of metal such as copper, with indentations in the material acting as blasting lens as to assure an instant elimination of the rigid casing 945, enabling a blast wave 944 to reach the main body of the RPG29 (for example).

[0121] In yet another non-limiting embodiment shown in FIG. 15H a combined module 1000 comprises an array of modules as described, for example in FIG. 15F, is provided. The explosive charge module 979 is placed in proximity to module 1000 and may be detonated in conjunction with the activation of the module 1000. In yet another embodiment, a partial activation of any of the elements comprising the module 1000 may activate the explosive charge 979. In yet another embodiment, the explosive charge 979 may be detonated by an independent triggering mechanism associated with sensing elements known in the art. In yet another embodiment, the explosive charge 979 may be detonated by an independent triggering mechanism associated with sensing elements known in the art in conjunction with a blast sequence associated with the activation of module 1000.

[0122] As shown in FIG. 15h, an additional screen 9210 is provided. The screen 9210 may be placed either in front of screen 921, or behind it or in proximity to it as to be activated by an incoming HEAT jet, triggering the explosive charge 944 in accordance with a predetermined blast sequence. As a non-limiting example, the detonation of charge 944 may be delayed by the use of a slow-reacting detonator as part of charge 944.

[0123] In a further embodiment, reactive armour module 1005 may be used, and a single triggering screen 1002 may trigger both its own explosive layer 976 and module 979, the latter via wire 977 which may introduce a delay.

[0124] As shown in inset 1006, an ERA module such as module 1000 or 1005 may be located in the center of a cluster of explosive modules 979. The module in the center may be an ERA module according to the present embodiments or may be any kind of existing ERA module.

[0125] In yet another non-limiting embodiment a triggering mechanism known in the art or as described above is to augment ERA modules known in the art by attaching/

inserting a blast mechanism such as detonator or any other blast mechanism as to be activated by the triggering mechanism described above.

[0126] In yet another non-limiting embodiment a triggering mechanism to activate an ERA as described herein may be associated with a radar system/an electro-optical system which is placed on the protected platform in order to detect an incoming missile, thereby to preemptively activate or arm any of the embodiments of the system of the invention.

[0127] In yet another non-limiting embodiment a triggering mechanism of the invention as described above may be associated with the explosive module 979 as to augment known in the art ERA/NERA.

[0128] In yet another non-limiting embodiment a triggering mechanism known in the art may be associated with the explosive module 979 as to augment any known in the art ERA/NERA.

[0129] It should be noted, that wherein an ERA/NERA is an integral part of the armor of a vehicle as in modern MBT's (Modern Battle Tanks), the system according any embodiment of the invention can either augment existing armor or replace it.

[0130] In yet another non-limiting embodiment, detonator 980 is activated by the triggering mechanism 921, via communication element, such as wire, 977. The blast of explosive charge 944 can be timed via the usage of a detonator having a slower response time. The entire blasting unit 940 may be attached in an elevated position with respect to module 920, or placed on top of it or beside it. This unit is intended to destroy the main body of a tandem charge, such as the RPG29. The blasting unit may be covered by a protective shield, made of bullet proof material, as to avoid damage to the charge. In the event that a rigid casing 945 made of metal is used to cover the charge, the internal part of the cover may be grooved as to allow a quick release of the explosive energy through the case. In another embodiment, the explosive material is molded in a manner known in the art into a structure made of metal such as copper, with indentations in the material acting as blasting lens as to assure an instant elimination of the rigid casing 945, enabling a blast wave 944 to reach the main body of the RPG29 (for example).

[0131] As described above, high explosive is sandwiched between steel plates in the various modules of the invention. Upon detonation of the high explosive, one or more of the metal plates are ejected towards the incoming jet deforming it. As to improve the jet deformation capability of the plates, each of the plates may contain several layers as shown in FIG. 17. In a non-limiting embodiment, a single plate 1100 may consist of two sheets of rigid material such as steel, L1 and L2, respectively, and a layer of a high density polymer L3 such as polycarbonate. The high density polymer may be perforated P1, P2, . . . Pn to reduce the overall areal density of L3 and of the entire plate 1100. The high density polymer perforation P might be filled with, for example, air or with other substances such as liquid, solid materials, or high explosive material.

[0132] The thickness t of the high density polymer may vary as to create a gap between the steel layers in accordance with a predesigned specification. In another embodiment of the invention the high density polymer may be substituted by a rigid material such as aluminum and/or laminated composites known in the art. The thickness t of the layer L3 between the two steel plates may vary wherein one side $t1$

may be thinner, the other t_2 thickness causing the steel plates to have an angle between them. It should be noted the layer L3 may comprise a plurality of elements that reside one beside to the other. It should be noted said that the sandwich structure may comprise any number of such layers L1, L2, and L3. It should also be noted that the thickness of plates L1 and L2 may vary. Furthermore, the sandwich structure may also be used in any ERA/NERA module. In a non-limiting example, a 10 mm thickness of a steel front plate may be reconstructed as a 5 mm steel layer L1, $t_1=20$ mm $t_2=20$ mm heavily perforated polycarbonate layer L3, and a rear plate L2 having a thickness of 5 mm. In another non-limiting example, a 10 mm thickness of a steel front plate may be reconstructed as 5 mm steel layer L1, $t_1=20$ mm $t_2=10$ mm heavily perforated polycarbonate layer L3, and a rear plate L2 having a thickness of 5 mm.

[0133] it should be noted that that the term “steel” in this document may be used as well as synonyms for a plurality of rigid materials and or alloys with ballistic stopping capabilities.

[0134] While some embodiments of the invention have been described by way of illustration, it will be apparent that the invention can be carried into practice with many modifications, variations and adaptations, and with the use of numerous equivalents or alternative solutions that are within the scope of persons skilled in the art, without departing from the spirit of the invention or exceeding the scope of the claims.

1. Reactive armour comprising:
 - an explosive reactive armour module comprising a protective cover, a first triggering screen behind said protective cover, and an explosive layer; and
 - at least one explosive module placed in proximity to said reactive armour module and connected to said first triggering screen for detonation.
2. The reactive armour of claim 1, wherein said explosive module comprises a first shaped charge.
3. The reactive armour of claim 1 or claim 2, wherein the explosive reactive armour module comprises a second shaped charge.
4. The reactive armour of claim 2 or claim 3, wherein at least one of the first and second shaped charge comprises at least one cavity or at least one groove.
5. The reactive armour of any one of the preceding claims, further comprising a layer of rigid particles, the particles arranged to form a particle cloud for disrupting an incoming jet.
6. The reactive armour of any one of the preceding claims, wherein at least some of the rigid particles in the particle layer comprise a rigid core surrounded by a relatively less rigid shell.
7. Reactive armour module comprising an explosive layer triggerable by an incoming projectile, said layer being shaped in order to provide a shear component of a blast against said incoming projectile.
8. The reactive armour module of claim 7, wherein said explosive layer comprises a shaped charge.
9. The reactive armour module of claim 8 or claim 9, wherein said explosive layer comprises at least one explosive lens.
10. The reactive armour module of claim 7, 8 or 9, wherein said explosive layer is unevenly distributed over said module, thereby to form a disruptive wavefront.
11. The reactive armour module of any one of claims 7 to 10, wherein said explosive layer comprises at least one shaped region comprising at least one cavity or at least one groove.
12. The reactive armour module of any one of claims 7 to 11, further comprising a layer of rigid particles, the particles arranged in relation to said explosive layer to form a particle cloud for disrupting an incoming jet following detonation of the explosive layer.
13. The reactive armour module of claim 12, wherein at least some of the rigid particles in the particle layer comprise a rigid core surrounded by a relatively less rigid shell.
14. Reactive armour module comprising a first extremity and a second extremity, first and second steel layers extending between said first extremity and said second extremity, said first and second steel layers being lined with respective explosive layers, a first explosive charge at said first extremity adjacent said first steel layer and a second explosive charge at said second extremity adjacent said second steel layer, and a trigger screen configured to detonate said first and second explosive charges in a timed manner in response to an incoming projectile in order to create a scissoring explosive effect.
15. The reactive armour module of claim 14, wherein said first and second explosive charges are shaped charges.
16. The reactive armour module of claim 14 or claim 15, further comprising a layer of rigid particles, the particles arranged in relation to said explosive layer to form a particle cloud for disrupting an incoming jet following detonation of the explosive layer.
17. The reactive armour module of claim 16, wherein at least some of the rigid particles in the particle layer comprise a rigid core surrounded by a relatively less rigid shell.
18. Reactive armour module comprising a plurality of explosive layers, each of said explosive layers being triggerable in response to an incoming projectile, each of said explosive layers being constructed from an explosive material having a different rate of detonation.
19. The reactive armour module of claim 18, further comprising at least one layer of rigid particles, the particles arranged in relation to said plurality of explosive layers to form a particle cloud for disrupting an incoming jet following detonation of the explosive layer.
20. The reactive armour module of claim 20, wherein at least some of the rigid particles in the particle layer comprise a rigid core surrounded by a relatively less rigid shell.
21. The reactive armour module of any one of claims 18 to 20, wherein at least one of said explosive layers comprises a shaped charge.
22. The reactive armour module of any one of claims 18 to 21, wherein at least one of said explosive layers comprises at least one explosive lens.
23. The reactive armour module of any one of claims 18 to 22, wherein at least one of said explosive layers is unevenly distributed over said module, thereby to form a disruptive wavefront.
24. The reactive armour module of any one of claims 18 to 23, wherein at least one of said explosive layers comprises at least one shaped region comprising at least one cavity or at least one groove.
25. Reactive armour module according to any one of claims 7 to 24, comprising at least one explosive layer which

is shaped into a plurality of explosive lenses, the lenses being triggerable to provide a shear force against an incoming projectile.

26. Reactive armour module according to any one of claims 7, to 25, further comprising a triggering screen for triggering said explosive layer or at least one of said explosive layers.

27. Reactive armour module according to claim 26, wherein the screen is divided into at least two triggering parts, each part triggered by a different approach angle of an incoming projectile and each part configured to initiate an explosion in a different part of said explosive layer.

28. Reactive armour module according to any one of claims 7 to 27, configured to detonate different explosive layers or different parts of respective explosive layers in a timed sequence.

29. Reactive armour module according to any one of claims 7 to 28, the module having a planar surface and comprising at least one steel plate, the steel plate having at least one layer of high explosive attached thereto, the steel plate being angled with respect to said planar surface.

30. Reactive armour module according to any one of claims 7 to 28, the module having at least one explosive layer sandwiched on either side by steel plates.

31. Reactive armour module according to claim 30, comprising two explosive layers, each sandwiched on either side by steel plates, one of said layers being placed outwardly on said module and one of said layers being placed inwardly on said module, said outer layer comprising an explosive material with a detonation rate that is lower than a corresponding detonation rate of said inner layer.

32. Reactive armour module of claim 31, comprising a third explosive layer sandwiched on either side by steel plates, said third explosive layer being placed outwardly of both of said two explosive layers and having a detonation rate which is faster than both of said two explosive layers.

33. Reactive armour module comprising an explosive layer, the layer being shaped into a plurality of explosive lenses, the lenses being triggerable to provide a shear force against an incoming projectile.

34. Reactive armour module comprising an explosive layer and a triggering screen, the screen divided into at least two triggering parts, each part triggered by a different approach angle of an incoming projectile and each part configured to initiate an explosion in a different part of said explosive layer.

35. An explosive reactive armour module comprising a protective cover, a first triggering screen behind said protective cover, and an explosive layer.

36. Reactive armour comprising:

an explosive reactive armour module comprising a protective cover, a first triggering screen behind said protective cover, and an explosive layer; and
at least one explosive module placed in proximity to said reactive armour module.

37. The reactive armour of claim 36, wherein said explosive module comprises a first shaped charge.

38. The reactive armour of claim 36 or claim 37, wherein the explosive reactive armour module comprises a second shaped charge.

39. The reactive armour of claim 37 or claim 38, wherein at least one of the first and second shaped charge comprises at least one cavity or at least one groove.

40. The reactive armour of any one of claims 36 to 39, further comprising a layer of rigid particles, the particles arranged to form a particle cloud for disrupting an incoming jet.

41. The reactive armour of any one of claims 36 to 40, wherein at least some of the rigid particles in the particle layer comprise a rigid core surrounded by a relatively less rigid shell.

* * * * *