

(No Model.)

C. ADAMS.

DIVISIBLE BULLET PROOF SHIELD.

No. 377,732.

Patented Feb. 14, 1888.

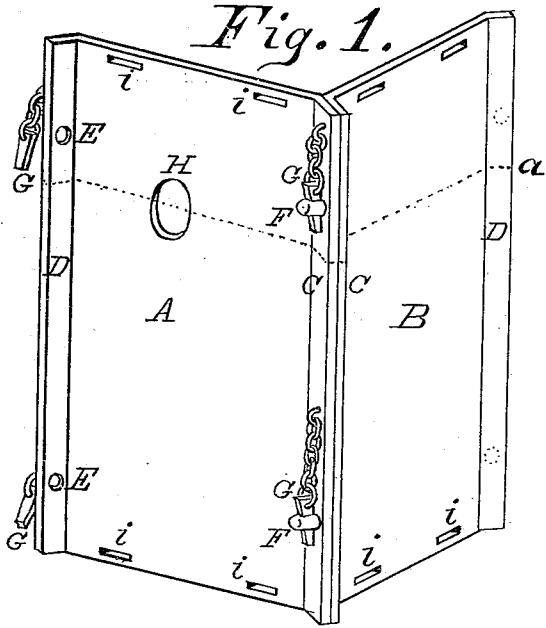

Fig. 1.

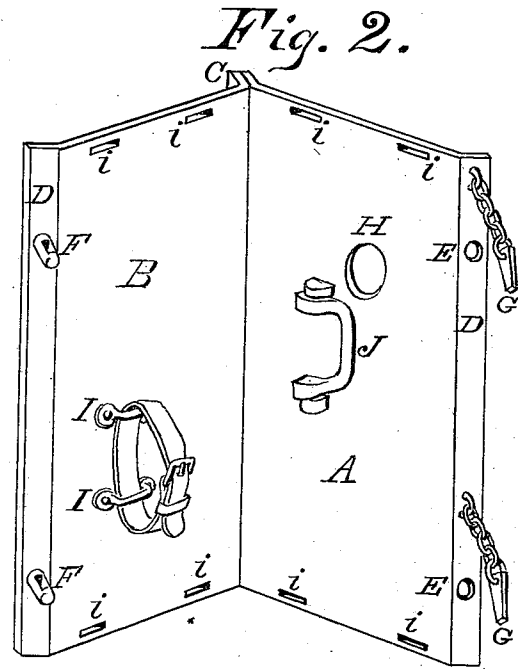

Fig. 2.

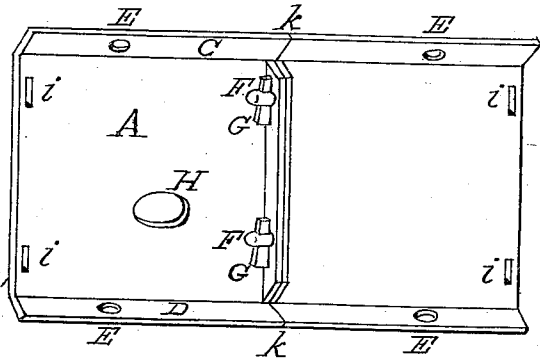

Fig. 3.

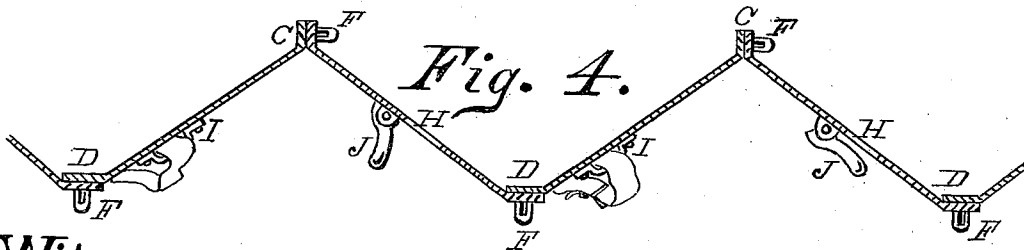

Fig. 4.

Witnesses:

Charles Adams.
James Thomson

Inventor,

Charles Adams

UNITED STATES PATENT OFFICE.

CASSILLY ADAMS, OF CINCINNATI, OHIO.

DIVISIBLE BULLET-PROOF SHIELD.

SPECIFICATION forming part of Letters Patent No. 377,732, dated February 14, 1888.

Application filed July 3, 1885. Serial No. 170,579. (No model.)

To all whom it may concern:

Be it known that I, CASSILLY ADAMS, a citizen of the United States, residing at Cincinnati, Hamilton county, State of Ohio, have invented a new and useful Divisible Bullet-Proof Shield, of which the following is a specification.

This invention relates to those portable bullet-proof shields which are capable of being conveniently carried either by infantry or mounted men while on the march, and yet can be used for protecting each individual soldier, or can be readily arranged to serve as a breastwork for sheltering a line of men from the enemy's fire; and my improvement comprises such a construction of shield as will of necessity produce a continuous zigzag or chevron-shaped barricade the moment a breastwork is erected. To accomplish this result, each shield is composed of a pair of plates of any suitable material—steel or iron being preferred for obvious reasons—the vertical margins of these plates being bent to form obtuse angles, and being provided with convenient retaining devices wherewith said plates are united. As a natural result of this arrangement of said flanges the plates are disposed at a proper angle with reference to each other, and the coupling together of a number of such plates or sections causes the breastwork or barricade to assume a continuous zigzag, chevron, or dancette shape, which defense can be erected in a few minutes and without requiring any special skill on the part of the soldier or calling in the aid of an engineer to run the lines for the works.

In the annexed drawings, Figure 1 is a perspective view of the front side of a shield embodying my improvements. Fig. 2 is a perspective view of the rear side of the shield. Fig. 3 is a perspective view of a modification of my invention. Fig. 4 is a horizontal section of a number of shields coupled together, so as to form a continuous zigzag breastwork or barricade, said section being taken at the dotted line *a* of Fig. 1.

Each individual shield consists of a pair of bullet-proof plates or sections, A B, of any suitable size and material, the two vertical margins of each plate being bent to form ob-

tuse-angled flanges C C at the inner edges of said plates. The outer edges of said plates are bent to constitute flanges D, which latter are parallel with the base-line of the triangle formed by joining together a pair of such plates A B. These flanges have circular holes E, supplemented by pins F on the opposing flanges, which devices E F are united by tapering keys G. Attached to the rear side of plate B are staples or loops I I, to which a strap is fastened for supporting the shield upon the soldier's left arm, while his hand grasps the handle J of the other plate, A.

Handle J is hinged to said plate, so as to be turned down flat, and thereby economize space in transportation.

There are loop-holes in the plate A, and *i i* are slots near the edges of the latter, which slots admit straps wherewith the soldier carries the shield; or they may receive other straps or fastenings when a number of said plates are nested together for shipment.

It is evident that when a number of these shields are fitted together and properly secured they must of necessity form a continuous zigzag, chevron, or dancette shaped breastwork, as seen in Fig. 4, behind which barricade the soldiers are protected and discharge their guns either through the various portholes H or over the top of said shields, as may be the most effective. Furthermore, it is apparent this zigzag barricade is formed at once by the soldiers, and without any special skill on their part, the only precaution necessary being to insert the pins in the appropriate holes and then drive the keys G into the slots of said pins.

Fig. 3 shows a modification of my invention, in which two upper sections, *k k*, are coupled to the main plates of the shield.

I claim as my invention—

1. A shield for the protection of a single man, which shield consists of two portable bullet-proof plates, each plate being provided with a pair of vertical obtuse-angled flanges united by readily-detachable retaining devices, in order that the coupling together of a number of such shields will of necessity form a continuous zigzag or chevron-shaped breastwork, as herein described.

2. A shield for the protection of a single man, which shield consists of two portable bullet-proof plates, each plate being furnished with a pair of vertical obtuse-angled flanges united by readily-detachable retaining devices, in order that the coupling together of a number of such shields will of necessity form a continuous zigzag or chevron-shaped breast-

work, one of said plates being provided with a port-hole, H, and handle J, and the other plate having a strap attached thereto, for the purpose specified.

CASSILLY ADAMS.

Witnesses:

CHARLES C. ADAMS,
JAMES THOMSON.