



(11) **EP 1 741 987 A1**

(12) **EUROPEAN PATENT APPLICATION**  
published in accordance with Art. 158(3) EPC

(43) Date of publication:  
**10.01.2007 Bulletin 2007/02**

(51) Int Cl.:  
**F24C 1/00 (2006.01) F24C 7/02 (2006.01)**  
**F24C 15/32 (2006.01)**

(21) Application number: **05734622.3**

(86) International application number:  
**PCT/JP2005/007521**

(22) Date of filing: **20.04.2005**

(87) International publication number:  
**WO 2005/106332 (10.11.2005 Gazette 2005/45)**

(84) Designated Contracting States:  
**DE FR GB**

- **YAMASAKI, Takahiko**  
c/o Matsushita Electric Industr  
Chuo-ku Osaka-shi Osaka 540-6319 (JP)
- **INADA, Ikuhiro**  
c/o Matsushita Electric Industrial  
Chuo-ku Osaka-shi Osaka 540-6319 (JP)

(30) Priority: **27.04.2004 JP 2004130930**

(71) Applicant: **MATSUSHITA ELECTRIC INDUSTRIAL CO., LTD.**  
**Osaka 571-8501 (JP)**

(74) Representative: **Grünecker, Kinkeldey, Stockmair & Schwanhäusser**  
**Anwaltssozietät**  
**Maximilianstrasse 58**  
**80538 München (DE)**

(72) Inventors:  
• **UCHIYAMA, Satomi**  
c/o Matsushita Electric Industria  
Chuo-ku Osaka-shi Osaka 540-6319 (JP)

(54) **COOKER**

(57) It is an object of the invention to provide a cooking apparatus which can set the interior of a heating chamber at desired humidity and temperature in a short time.

In the cooking apparatus, an object to be heated 11 is stored into a heating chamber 12, the interior of the heating chamber 12 is heated up to a given temperature using heating chamber interior heating means 13, and water supplied to a storage part 17 formed within the heating chamber by water supply means 16 is heated using storage part heating means 18 to thereby generate and supply steam. At the then time, based on the temperature of the interior of the heating chamber detected by heating chamber interior temperature detect means 20, a control part 19 controls the storage part heating means 18 in such a manner that the water in the storage part 17 is prevented from boiling on, before the steam is supplied. That is, since, by supplying the steam not boiling, the supply of the steam can be executed without increasing the temperature of the interior of the heating chamber, the excessive progress of fermentation can be prevented and thus the proper fermentation can be carried out.

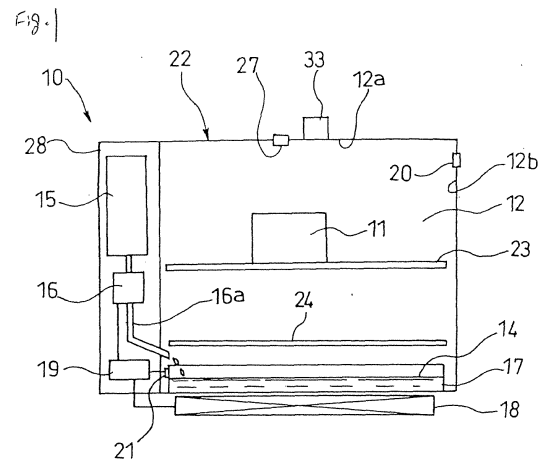

**EP 1 741 987 A1**

**Description**

<Technical Field>

**[0001]** The present invention relates to a cooking apparatus and, specifically, the invention relates to a cooking apparatus which can be used to ferment dough.

<Background Art>

**[0002]** Since, when fermenting dough, there is used yeast which is a living thing, when the temperature of the interior of a heating chamber is too high or the humidity thereof is too high, the fermented state of the dough is poor. In view of this, in a conventional cooking apparatus which does not have a steam function, a user manually sprays steam into the heating chamber to adjust the humidity within the heating chamber. However, in the conventional cooking apparatus, it is troublesome to control the temperature and humidity.

**[0003]** To solve this problem, there has been developed a microwave oven which can spray steam into the heating chamber to control the humidity within the heat chamber (see, for example, the patent reference 1).

**[0004]** Here, Fig. 6 shows a microwave oven 100 which is a cooking apparatus disclosed in the patent reference 1. The microwave oven 100 includes a heating chamber 101 in the interior thereof and, in the front opening portion of the heating chamber 101, there is disposed a door (not shown) in such a manner that it can be freely opened and shut. In the upper and lower portions of the heating chamber 101, there are respectively disposed heaters 102, 102 which function as heating means; and, between these heaters, there is interposed a cooking dish 103. On the upper wall 101a of the heating chamber 101, there are disposed a magnetron 104, a humidity sensor 105, a thermistor 106 and the like; and, in the upper wall 110a, there is formed a vent 107. Also, in the side wall 101b of the heating chamber 101, there is formed one end portion 108a of a steam conduit 108 in such a manner that it is open to the heating chamber, whereas the other end portion 108b is open to a tank 109. On the tank 109, there is disposed a heater 110. By the way, the microwave oven 100 includes a control unit (not shown) which controls the magnetron 104, humidity sensor 105, thermistor 106, heater 110 functioning as heating means, and other similar parts.

[Patent Reference 1]: JP58-31931 (Fig. 2)

<Disclosure of the Invention>

<Problems that the Invention is to Solve>

**[0005]** By the way, in the above-mentioned microwave oven 100, while measuring the humidity of the interior of the heating chamber 101 using the humidity sensor 105, the control unit, based on the measured result, controls the heater 110 to adjust the amount of steam to be

sprayed into the heating chamber 101, thereby setting the interior of the heating chamber 101 at a desired humidity. In other words, because water is boiled in the tank 109 separately disposed from the heating chamber and steam generated from the boiling water is sprayed into the heating chamber 101, the temperature of the steam is almost the boiling temperature. Therefore, since such high temperature steam is sprayed into the heating chamber 101, the temperature of the interior of the heating chamber 101 rises to thereby facilitate the fermentation of the dough excessively.

**[0006]** The invention is made in view of the above-mentioned problem and thus it is an object of the invention to provide a cooking apparatus which can set the interior of the heating chamber at desired humidity and temperature in a short time.

<Means for Solving the Problems>

**[0007]** In attaining the above object, according to the invention, there is provided a cooking apparatus capable of supplying steam into a heating chamber with an object to be heated stored therein. Specifically, the present cooking apparatus comprises: heating chamber interior heating means for heating the interior of a heating chamber; water supply means for supplying water into the heating chamber; a storage part for storing the water within the heating chamber; storage part heating means for heating the water stored in the storage part; control part for controlling the heating chamber interior heating means, the water supply means and the storage part heating means; heating chamber interior temperature detect means for detecting the temperature of the interior of the heating chamber; and, storage part temperature detect means for detecting the temperature of the storage part heating means or the temperature of the storage part, wherein the control part controls the storage part heating means and the water supply means based on the temperature of the interior of the heating chamber in such a manner that the water in the storage part is prevented from boiling on.

**[0008]** In the thus structured cooking apparatus, an object to be heated is stored into the heating chamber, the interior of the heating chamber is heated up to a given temperature using the heating chamber interior heating means, water supplied to the storage part of the interior of the heating chamber by the water supply means is heated, and the thus generated steam is supplied into the heating chamber. At the then time, the control part, based on the temperature of the interior of the heating chamber detected by the heating chamber interior temperature detect means, controls the storage part heating means and the water supply means to supply the steam into the heating chamber in such a manner that the water in the storage part is prevented from boiling on. In other words, by supplying the steam that is not boiling, the steam is supplied into the heating chamber without increasing the temperature of the interior of the heating

chamber, which can prevent the excessive fermentation of the object to be heated and thus makes it possible to carry out the fermentation properly. Here, the storage part heating means can be controlled using PWM (Pulse Width Modulation). Also, the storage part heating means can also be controlled in such a manner that it is turned on and off, or it can also be inverter controlled.

**[0009]** Also, according to the invention, there is provided a cooking apparatus capable of supplying steam into a heating chamber with an object to be heated stored therein. Specifically, the present cooking apparatus comprises: heating chamber interior heating means for heating the interior of a heating chamber; water supply means for supplying water into the heating chamber; a storage part for storing the water within the heating chamber; storage part heating means for heating the water stored in the storage part; control part for controlling the heating chamber interior heating means, the water supply means and the storage part heating means; heating chamber interior temperature detect means for detecting the temperature of the interior of the heating chamber; and, storage part temperature detect means for detecting the temperature of the storage part heating means or the temperature of the storage part, wherein the control part controls the storage part heating means and the water supply means based on the temperature of the interior of the heating chamber and the temperature of the storage part in such a manner that the water in the storage part is prevented from boiling on.

**[0010]** In the thus structured cooking apparatus, an object to be heated is stored into the heating chamber, the interior of the heating chamber is heated up to a given temperature using the heating chamber interior heating means, water supplied to the storage part of the interior of the heating chamber by the water supply means is heated, and the thus generated steam is supplied into the heating chamber. At the then time, the control part, based on the temperature of the interior of the heating chamber detected by the heating chamber interior temperature detect means and the temperature of the storage part detected by the storage part temperature detect means, controls the storage part heating means and the water supply means to supply the steam into the heating chamber in such a manner that the water in the storage part is prevented from boiling on. In other words, by supplying the steam that is not boiling, the steam is supplied into the heating chamber without increasing the temperature of the interior of the heating chamber, which can prevent the excessive fermentation of the object to be heated and thus makes it possible to carry out the fermentation properly. Here, the storage part heating means can be controlled using PWM (Pulse Width Modulation). Also, the storage part heating means can also be controlled in such a manner that it is turned on and off, or it can also be inverter controlled.

**[0011]** Also, the present cooking apparatus is characterized in that the control part not only controls the water supply means and storage part heating means in such a

manner that, after the water in the storage part is boiled once, the water is prevented from boiling on, but also, based on the temperature detected by the heating chamber interior detect means, controls the temperature of the interior of the heating chamber at a desired temperature using the heating chamber interior heating means.

**[0012]** In the thus structured cooking apparatus, since the control part controls the water supply means and storage part heating means in such a manner that, after the water in the storage part is boiled once, the water is prevented from boiling on, not only an increase in the temperature of the steam can be prevented but also an increase in the temperature of the interior of the heating chamber due to supply of the steam can be prevented. Also, because the control part controls the heating chamber interior heating means based on the temperature detected by the heating chamber interior temperature detect means, the temperature of the interior of the heating chamber can be controlled to a desired temperature.

**[0013]** And, the present cooking apparatus is characterized in that there are set two or more control levels for controlling the temperature of the storage part based on the temperature detected by the storage part temperature detect means: that is, firstly, the storage part temperature is controlled at a first level, and, from then on, the storage part temperature is controlled at a second level.

**[0014]** In the thus structured cooking apparatus, there are set two or more control levels for controlling the storage part heating means: that is, in the first control level, the storage part heating means is controlled at a high level to heat the water in the storage part quickly and, from then on, it is controlled at the second level which is lower than the first level, thereby supplying a given amount of steam.

**[0015]** Also, the present cooking apparatus is characterized in that there are set two or more control levels for controlling the temperature of the interior of the heating chamber based on the temperature detected by the heating chamber interior temperature detect means, and the storage part heating means is controlled at the highest level of the thus set heating chamber interior temperature control levels.

**[0016]** In the thus structured cooking apparatus, there are set two or more control levels for controlling the heating chamber interior temperature according to the temperature detected by the heating chamber interior temperature detect means, and the storage part heating means is controlled at the highest level of the thus set control levels, whereby the amount of supply of steam is maximized while minimizing an increase in the temperature of the interior of the heating chamber.

**[0017]** Further, the present cooking apparatus is characterized in that the control part controls the storage part heating means in such a manner that, when the temperature of the storage part exceeds the temperature of the interior of the heating chamber, the water in the storage part is prevented from boiling.

**[0018]** In the thus structured cooking apparatus, since the storage part heating means is controlled so as to prevent the water in the storage part from boiling, generation of an excessive amount of steam can be prevented and thus the humidity of the interior of the heating chamber can be maintained at a proper level.

**[0019]** Also, the present cooking apparatus is characterized by ventilating means for feeding the air into the heating chamber. The ventilating means is controlled in such a manner that the temperature of the interior of the heating chamber can be set a temperature proper for fermentation based on the temperature detected by the heating temperature interior temperature detect means.

**[0020]** In the thus structured cooking apparatus, the control part controls the ventilating means based on the temperature detected by the heating chamber interior temperature detect means to thereby set the interior of the heating chamber at a proper temperature for fermentation.

<Brief Description of the Drawing>

**[0021]**

Fig. 1 is a front view of an ordinary microwave oven having a steam function which is an embodiment of a cooking apparatus according to the invention.

Fig. 2 is a side view of the microwave oven shown in Fig. 1.

Fig. 3 is a block diagram of the structure of a control part and a control system.

Fig. 4 is a graphical representation of the control contents to be executed by the control part.

Fig. 5 is a comparison table for showing fermentation states provided according to steam fermentation control by heating sources.

Fig. 6 is a structure view of a conventional cooking apparatus.

<Description of Reference Numerals>

**[0022]**

- 10: Microwave oven (Cooking apparatus)
- 11: Object to be heated
- 12: Heating chamber
- 13: Heater (Heating chamber interior heating means)
- 14: Water
- 15: Tank (Water supply means)
- 16: Water pump (Water supply means)
- 17: Evaporation dish (Storage part)
- 18: Storage part heating part (Storage part heating means)
- 19: Control part
- 20: Heating chamber interior thermistor (Heating chamber interior temperature detect means)
- 21: Storage part thermistor (Storage part temperature detect means)

25: Convection heater (Heating chamber interior heating means)

26: Fan (Ventilating means)

5 <Best Mode for Carrying Out the Invention>

**[0023]** Now, description will be given below in detail of an embodiment of a cooking apparatus according to the invention with reference to the accompanying drawings.

10 Fig. 1 is a front view of an ordinary microwave oven having a steam function which is an embodiment of a cooking apparatus according to the invention, Fig. 2 is a side view of the microwave oven shown in Fig. 1, Fig. 3 is a block diagram of the structure of a control part and a control system, Fig. 4 is a graphical representation of the control contents to be executed by the control part, and Fig. 5 is a comparison table for showing fermentation states provided according to steam fermentation control by heating sources.

20 **[0024]** This microwave oven 10 is a cooking apparatus which can supply steam into a heating chamber 12 with an object to be heated 11 stored therein. Specifically, the cooking apparatus 10 comprises: a heater 13 serving as heating chamber interior heating means for heating the interior of the heating chamber 12; a tank 15 and a water pump 16 serving as water supply means for supplying water 14 into the heating chamber 12; an evaporation dish 17 serving as a storage part for storing the water 14 within the heating chamber 12; a storage part heating part 18 serving as storage part heating means for heating the water 14 in the evaporation dish 17; a control part 19 for controlling the heater 13, water pump 16 and storage part heating part 18; and, a heating chamber interior thermistor 20 serving as heating chamber interior temperature detect means for detecting the temperature of the interior of the heating chamber 12. Also, on the outer surface of the evaporation dish 17 serving as the storage part, there is provided a storage part thermistor 21 serving as storage part temperature detect means for detecting the temperature of the evaporation dish 17.

**[0025]** By the way, the storage part temperature detect means may measure the temperature of the water directly, or it may be disposed in the vicinity of the evaporation dish to measure the temperature of steam.

45 **[0026]** As shown in Figs. 1 and 2, the microwave oven 10 includes a main body 22 having, for example, a rectangular shape and also includes a heating chamber 12 in the inside thereof. On the front opening portion of the main body 22, there is disposed a door (not shown) in such a manner that it can be freely opened and shut, thereby being able to close the heating chamber 12 hermetically. On the upper wall 12a of the heating surface 12, there is provided an infrared sensor 27, thereby being able to measure the initial temperature of the interior of the heating chamber 12. By the way, this infrared sensor 27 is not be able to measure accurately the temperature of the interior of the heating chamber 12 after the interior of the heating chamber 12 is filled with steam. Also, on

the side wall 12b of the heating chamber 12, there is provided a heating chamber interior thermistor 20 serving as heating chamber interior temperature detect means for detecting the temperature of the interior of the heating chamber 12; and, the thermistor 20 always detects the temperature of the interior of the heating chamber 12 and feeds the detected temperature back to the control part 19.

**[0027]** The heaters 13 serving as heating chamber interior heating means are disposed respectively in the upper and lower portions of the heating chamber 12 and, between the upper and lower heaters 13, there are interposed a shelf 23 and a cooking dish 24 on which an object to be heated such as a food or dough can be placed. Also, on the back wall 12c of the heating chamber 12, there is provided a convection heater 24 and, in the rear of the convection heater 24, there is provided a fan 26 serving as ventilating means.

**[0028]** Thanks to this, the heating chamber 12 is structured such that, using not only the upper and lower heaters 13 and 13 but also the convection heater 25 and fan 26, a hot wind is forcibly convected to thereby heat the object to be heated 11. Also, the fan 26 can also be used to diffuse steam supplied to the heating chamber 12.

**[0029]** The evaporation dish 17, which is the storage part for storing the water 14 in the interior of the heating chamber 12, is disposed in the lower portion of the heating chamber 12. This evaporation dish 17 is used to store a small amount of, for example, about 20cc of, water 14 and is structured such that the water 14 can be evaporated in a short time by the storage part heating part 18 disposed downwardly of the evaporation dish 17. The storage part heating part 18 is disposed in contact with the lower surface of the evaporation dish 17 and is also arranged to heat the evaporation dish 17 uniformly but not suddenly through the main body 22 made of aluminum die cast heated by a heating member such as a Nichrome wire to thereby prevent the water 14 from boiling locally.

**[0030]** In a chamber 28 formed adjacent to the side surface of the heating chamber 12, there are stored the tank 15 and water pump 16; and, the water 14 stored in the tank 15 can be supplied through a pipe 16a by the water pump 16 to the evaporation dish 17 placed within the heating chamber 12. Therefore, the water 14 to be supplied to the evaporation dish 17 is water before heated, and thus the temperature of the water 14 is normally lower than the temperature of the interior of the heating chamber 12.

**[0031]** As shown in Fig. 3, the control part 19 includes: a compare and judge portion 29 for receiving detect signals from the heating chamber interior thermistor 20 and storage part thermistor 21 to compare the detected temperatures with the reference temperature; a water control portion 30 for controlling the water pump 16; a storage part heating control portion 31 for controlling the storage part heating part 18; a heating chamber interior heating control portion 32 for controlling the heaters 13 or the like

serving as the heating chamber interior heating means; and, other similar portions. By the way, on the upper wall 12a of the heating chamber 12, there is provided a magnetron 33, whereby the heating chamber 12 can be heated by microwaves.

**[0032]** Next, description will be given below of the control contents of the control part 19 with reference to Fig. 4. In the dough fermentation of a bread baking process, the fermentation time (the approximate time necessary for the dough to rise 2.5 to 3 times in size) varies greatly depending on the time taken for kneading the bread dough and, therefore, for example, when a temperature in the kneading operation is 27°C, it is necessary to keep the temperature of the interior of the heating chamber at the optimum temperature for fermentation, that is, a temperature in the vicinity of 30°C. The point of the bread bakery is to ferment the bread dough properly using yeasts, and the relationship between the fermentation temperature and time is the most important.

**[0033]** For example, when the fermentation time is too long and thus the bread dough is over-fermented in a first fermentation stage, the bread dough rises too much. When such bread dough is baked, the baked bread has no appetizing color but is rough in the skin and is heavy; and, in some cases, the bread can smell bad. Also, when the fermentation temperature is excessively high, the bread dough, as in the over-fermented case, rises too much. When such bread dough is baked, the baked bread has no baked color but is heavy and rough; and, in some cases, the bread can smell bad.

**[0034]** This is because the fermentation temperature is out of a temperature zone where the yeasts can increase most actively. For example, when the fermentation temperature is equal to or higher than 60°C, some of the yeasts can die. Also, with respect to the humidity of the heating chamber, preferably, the humidity may be 80% or so; and, what is important is that the surface of the bread dough can be prevented from drying. When the dough surface dries, the increase of the dough is poor and the skin of the dough is thick, resulting in the poor bread.

**[0035]** Firstly, the control level of the storage part heating part 18 is set for two or more levels (here, for example, 2 levels are set: that is, one level is a first or high level for boiling; and, the other is a second or low level for fermentation). For a minute after start of the fermentation, a heater for steam serving as the storage part heating part 18 is controlled at the first high level (storage part thermistor level (a)) for boiling to thereby quickly filling steam into the heating chamber 12.

**[0036]** After the steam is filled into the heating chamber for about a minute to set the interior of the heating chamber at a proper humidity, based on a detect signal from the heating chamber interior thermistor 20, or based on detect signals from the heating chamber interior thermistor 20 and storage part thermistor 21, the storage part heating part 18 is on and off controlled at the storage part thermistor level (b) lower than the first-time storage part

thermistor level (a) so as to be able to maintain the humidity suitable for fermentation (for example, 80% - 85%). Here, the storage part thermistor level (b) is a level which is applied to the second time and following times for filling the steam into the interior of the heating chamber to thereby maintain the proper humidity thereof. At the same time, the convection heater 25 serving as the heating chamber interior heating means is turned on to increase the temperature of the interior of the heating chamber, for example, up to the temperature range of 30°C - 35°C suitable for fermentation. By the way, as the need arises, a circulation fan 26 may be operated strongly or softly or turned off to thereby set uniform the temperature and humidity of the interior of the heating chamber.

**[0037]** After it is judged from the detected temperature from the heating chamber interior thermistor 20 that the temperature of the interior of the heating chamber has reached the proper temperature, the upper and lower heaters 13 as well as the convection heater 25 are turned off; and, in order that the temperature of the interior of the heating chamber can be maintained in the range suitable for fermentation, the storage part heating part 18 may be on/off controlled at the storage part thermistor level (b), and/or the intensity of the fan 26 may be controlled.

**[0038]** By the way, when the temperature detected by the heating chamber interior thermistor 20 lowers greatly, the convection heater 25 is turned on to increase the temperature of the interior of the heating chamber.

**[0039]** Even when the storage part heating part 18 is controlled at the storage part thermistor level (b) so as not to boil the water, the temperature of the interior of the heating chamber gradually increases; and, therefore, the storage part heating part 18 and fan 26 are controlled at a storage part thermistor level (d). Thanks to this control, while maintaining the humidity of the interior of the heating chamber at the humidity suitable for fermentation, the temperature thereof can also be maintained at the temperature suitable for fermentation.

**[0040]** Now, Fig. 5 shows fermentation states provided according to steam fermentation control methods by heating sources.

**[0041]** In the microwave fermentation using the magnetron 33, the humidity is short and thus the state of the interior of the heating chamber is not desirable. Also, it is difficult to maintain the temperature of the interior of the heating chamber and thus the state of the temperature thereof is not so desirable. Therefore, it is difficult to maintain constant the proper humidity and temperature of the interior of the heating chamber and thus, as a general evaluation, this fermentation control method is not so desirable.

**[0042]** In the heater fermentation using the convection heater 25, the humidity is short and thus the humidity state of the interior of the heating chamber is not desirable. However, it is easy to maintain the temperature of the interior of the heating chamber and thus the state of the temperature of the interior of the heating chamber is

good. Therefore, this fermentation method is a general method when using a cooking apparatus, and the humidity of the interior of the heating chamber is controlled by a user spraying steam into the interior of the heating chamber. As a general evaluation, this fermentation method is not so desirable.

**[0043]** In the steam fermentation, it is easy to supply a proper amount of steam and thus the state of the humidity of the interior of the heating chamber is good. However, it is difficult to maintain the temperature of the interior of the heating chamber and thus the state of the temperature of the interior of the heating chamber is not so desirable. Therefore, as a whole evaluation, the steam fermentation method is not so desirable.

**[0044]** In the case of the heater fermentation + steam, a sufficient amount of steam is supplied and the humidity can be controlled using equipment, so that the state of the humidity of the interior of the heating chamber is good. Also, because of use of two or more heating sources and also because of boiling energy for generating steam, the temperature of the interior of the heating chamber is difficult to maintain constant. Therefore, this method is not desirable from the viewpoint of maintaining constant the temperature of the interior of the heating chamber the temperature of the interior of the heating chamber. As a whole evaluation, this method is not desirable in that the temperature of the interior of the heating chamber is difficult to control.

**[0045]** In the case of heater fermentation + stirring operation (fan) + steam, a sufficient amount of steam is supplied and the humidity can be controlled using equipment, so that the state of the humidity of the interior of the heating chamber is good. Also, because the optimum control of the humidity using equipment is possible, as a whole evaluation, this method is desirable.

**[0046]** In the case of heater fermentation + stirring operation (fan) + steam with water not boiled, a sufficient amount of steam is supplied and the humidity can be controlled using equipment, so that the state of the humidity of the interior of the heating chamber is good. Also, since the water is not boiled when the steam is generated, the optimum control of the temperature of the interior of the heating chamber is possible, so that the state of the temperature of the interior of the heating chamber is very good. Therefore, since the temperature and humidity of the interior of the heating chamber can be set arbitrarily, the humidity, temperature and time can be controlled optimally and uniformly and, as a whole evaluation, this method is very good.

**[0047]** As has been described heretofore, according to the microwave oven 100 which is a cooking apparatus, not only because the temperature of the interior of the heating chamber 12 can be increased quickly up to a desired temperature but also because, by supplying the steam with the water not boiling, the steam can be supplied without increasing the temperature of the interior of the heating chamber 12, while preventing the excessive progress of the fermentation, the fermentation can be

carried out properly. Also, since the temperature of the steam is equal to or higher than the temperature of the interior of the heating chamber, by controlling the amount of the steam, the temperature of the interior of the heating chamber 12 can be maintained at a given temperature.

**[0048]** By the way, a cooking apparatus according to the invention is not limited to the above-mentioned embodiment but proper changes and modifications are also possible.

<Industrial Applicability>

**[0049]** According to the invention, not only since the temperature of the interior of the heating chamber can be increased up to a desired temperature but also since, by supplying steam with water not boiling, the steam can be supplied into the heating chamber without increasing the temperature of the interior of the heating chamber, the excessive progress of the fermentation can be prevented and thus the fermentation can be carried out properly.

### Claims

1. A cooking apparatus capable of supplying steam into a heating chamber with an object to be heated stored therein, comprising:

heating chamber interior heating means for heating the interior of a heating chamber;  
 water supply means for supplying water into the heating chamber;  
 a storage part for storing the water within the heating chamber;  
 storage part heating means for heating the water stored in the storage part;  
 control part for controlling the heating chamber interior heating means, the water supply means and the storage part heating means;  
 heating chamber interior temperature detect means for detecting the temperature of the interior of the heating chamber; and  
 storage part temperature detect means for the temperature of the storage part heating means or the temperature of the storage part;

wherein the control part controls the storage part heating means and the water supply means based on the temperature of the interior of the heating chamber in such a manner that the water in the storage part is prevented from boiling on.

2. A cooking apparatus capable of supplying steam into a heating chamber with an object to be heated stored therein, comprising:

heating chamber interior heating means for

heating the interior of a heating chamber;  
 water supply means for supplying water into the heating chamber;

a storage part for storing the water within the heating chamber;

storage part heating means for heating the water stored in the storage part;

control part for controlling the heating chamber interior heating means, the water supply means and the storage part heating means;

heating chamber interior temperature detect means for detecting the temperature of the interior of the heating chamber; and

storage part temperature detect means for the temperature of the storage part heating means or the temperature of the storage part, wherein the control part controls the storage part heating means and the water supply means based on the temperature of the interior of the heating chamber and the temperature of the storage part in such a manner that the water in the storage part is prevented from boiling on.

3. The cooking apparatus as set forth in Claim 1 or 2, wherein the control part not only controls the water supply means and storage part heating means in such a manner that, after the water in the storage part is boiled once, the water is prevented from boiling on, but also, based on the temperature detected by the heating chamber interior detect means, controls the temperature of the interior of the heating chamber at a desired temperature using the heating chamber interior heating means.
4. The cooking apparatus as set forth in Claim 1, 2, or 3, wherein there are set two or more control levels for controlling the temperature of the storage part based on the temperature detected by the storage part temperature detect means; and also wherein, firstly, the storage part temperature is controlled at first level, and, from then on, the storage part temperature is controlled at a second level.
5. The cooking apparatus as set forth in Claim 1, 2, or 3, wherein there are set two or more control levels for controlling the temperature of the interior of the heating chamber based on the temperature detected by the heating chamber interior temperature detect means, and the storage part heating means is controlled at the highest level of the thus set heating chamber interior temperature control levels.
6. The cooking apparatus as set forth in Claim 1, 2, or 3, wherein the control part controls the storage part heating means in such a manner that, when the temperature of the storage part exceeds the temperature of the interior of the heating chamber, the water in the storage part is prevented from boiling.

7. The cooking apparatus as set forth in any one of Claims 1 to 6, further including ventilating means for feeding the air into the heating chamber, wherein the ventilating means is controlled in such a manner that the temperature of the interior of the heating chamber can be set at a temperature proper for fermentation based on the temperature detected by the heating temperature interior temperature detect means.

5

10

15

20

25

30

35

40

45

50

55

Fig. 1

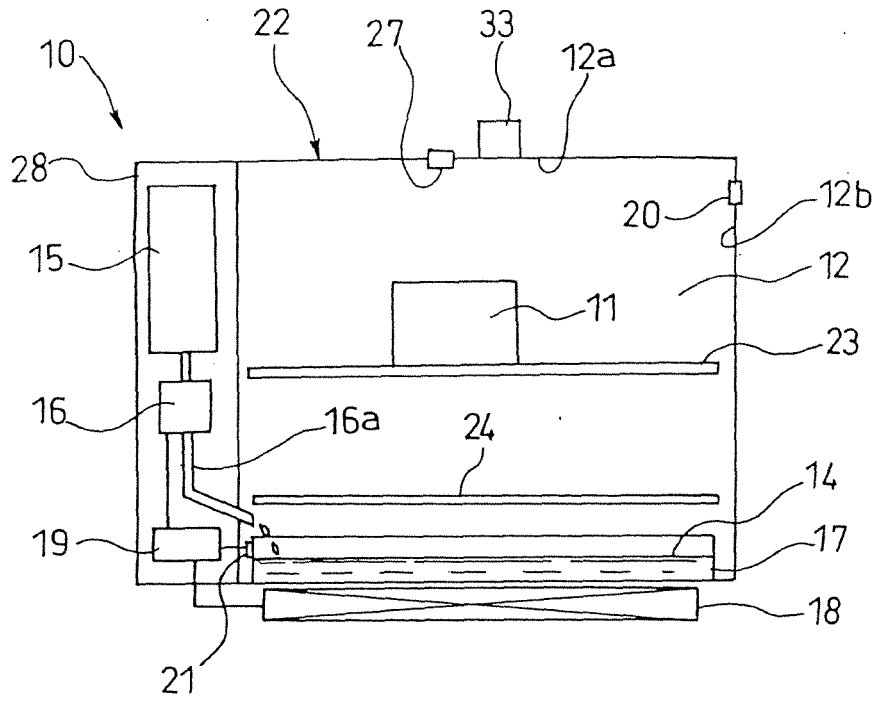

Fig. 2

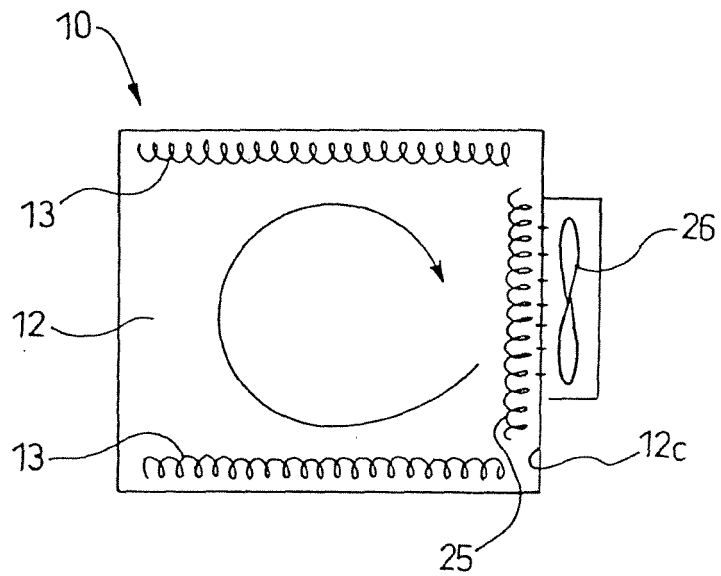
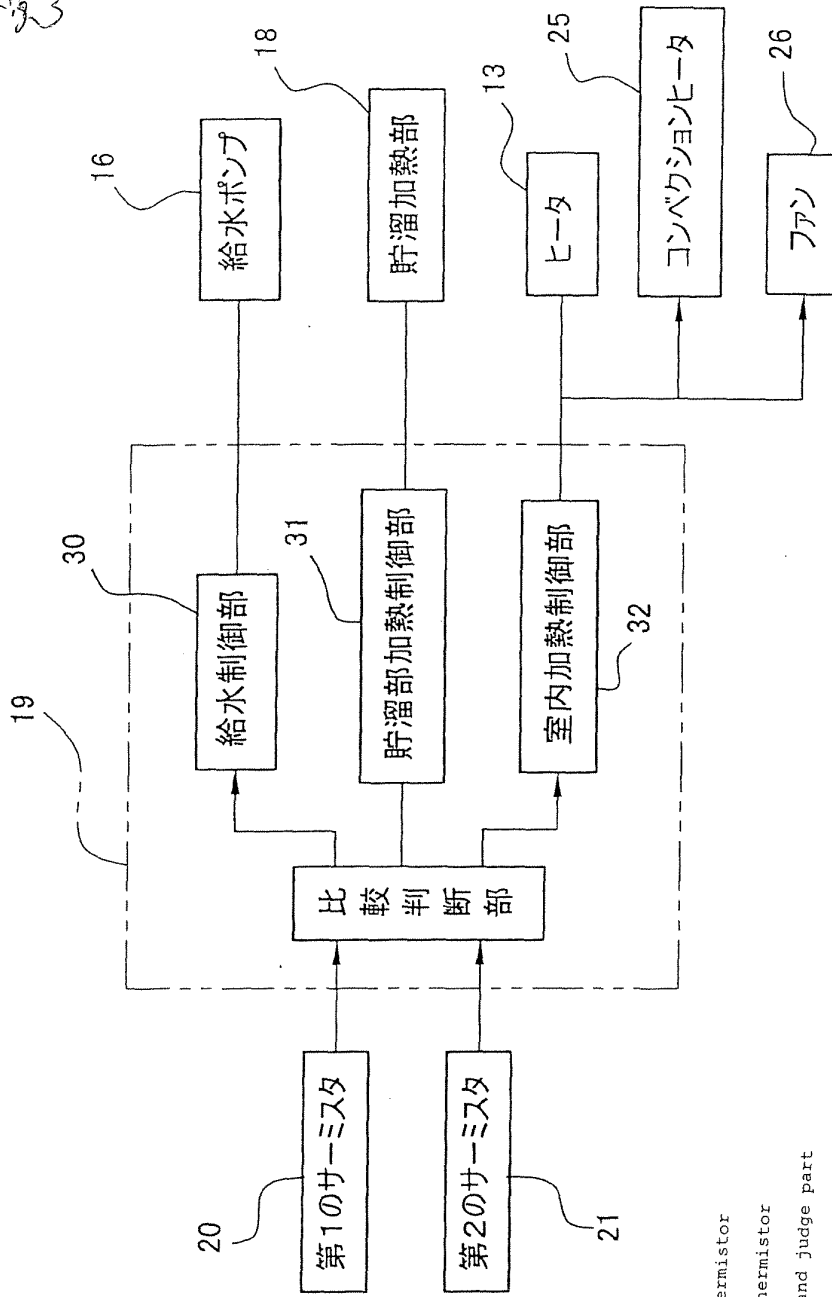

Fig. 3



[Fig. 3]

- 20: First thermistor
- 21: Second thermistor
- 19: Compare and judge part
- 30: Water supply control portion
- 31: Storage part heating control portion
- 32: Heating chamber interior heating control portion
- 16: Water pump
- 18: Storage part heating part
- 13: Heater
- 25: Convection heater
- 26: Fan

[Fig. 4]

- ① Heating chamber interior thermistor level
- ② Start of fermentation
- ③ Boiling state about for 1 minute
- ④ Second thermistor level
- ⑤ First thermistor level
- ⑥ Heater for steam
- ⑦ Circulation heater
- ⑧ Circulation fan
- ⑨ Humidity 80%

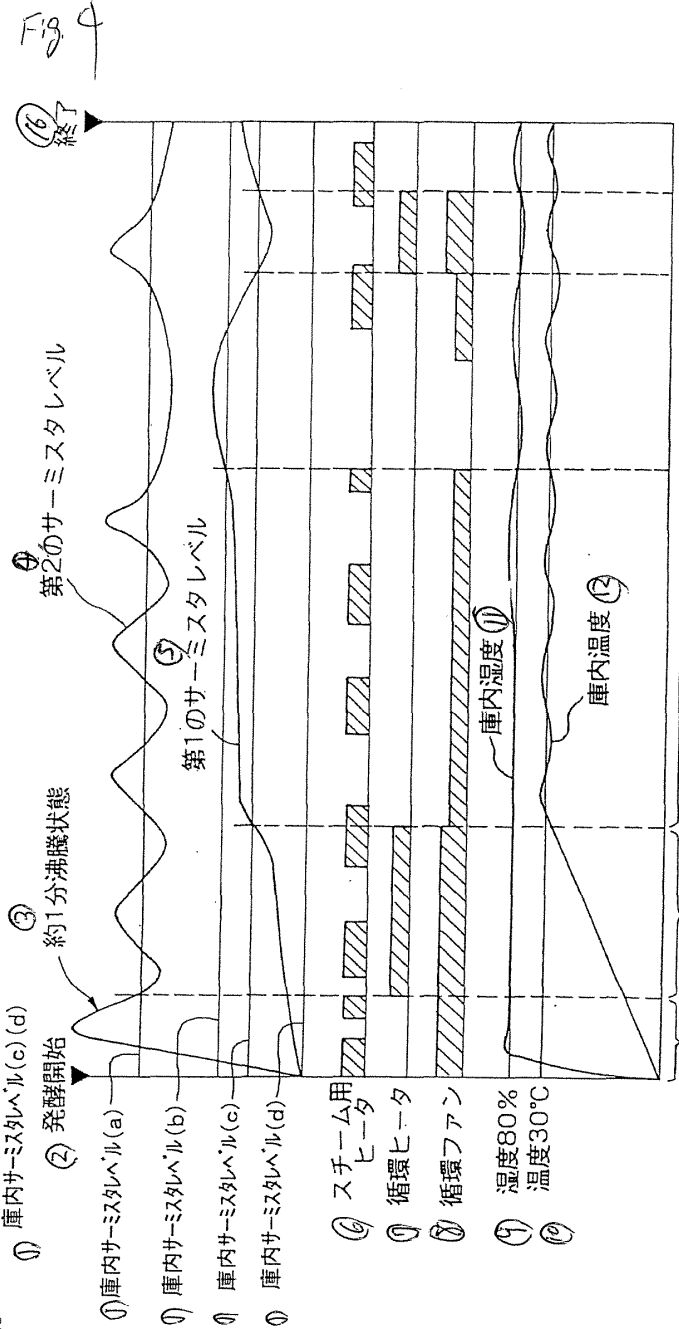

- ⑪ Temperature 30°C
- ⑫ Heating chamber interior humidity
- ⑬ Heating chamber interior temperature
- ⑭ Object is to fill steam into heating chamber to quickly set heating chamber interior at proper humidity.
- ⑮ Object is to quickly increase heating chamber interior temperature up to proper temperature.
- ⑯ Object is to maintain heating chamber interior at constant temperature and humidity.
- ⑰ End

Fig. 5

	庫内湿度状態 ⑪	庫内温度状態 ⑫	評価 ⑬
マイクロ波発酵 ⑪	× 湿度不足	△ 庫内温度維持が大変	△ 庫内の適湿・適温を一定に維持することが困難
ヒータ発酵 ⑫	× 湿度不足	○	調理器を用いる場合はこの方法が一般的
スチーム発酵 ⑬	○	△ 庫内温度維持が大変	△ 庫内の適温を一定に維持することが困難
ヒータ発酵 + スチーム ⑭	○ 機器による湿度コントロールが可能	△~○ 複数の加熱源 + 沸騰エネルギーにより、庫内温度の均一維持が大変	○ 任意設定により、調理器側で湿度・温度・時間の制御が可能
ヒータ発酵 + 攪拌 + スチーム ⑮	○ 機器による庫内湿度の最適コントロールが可能	○ 機器による庫内温度の最適コントロールが可能	○ 任意設定により、調理器側で湿度・温度・時間の制御が可能
ヒータ発酵 + 攪拌 + スチーム (沸騰させない制御) ⑯	○ 機器による庫内湿度の最適コントロールが可能	◎ 沸騰させない制御によりさらに庫内温度の最適コントロールが可能	◎ 任意設定により、調理器側で湿度・温度・時間の最適かつ均一制御が可能

[Fig. 5]

- ⑪ Microwave fermentation
- ⑫ Heater fermentation
- ⑬ Steam fermentation
- ⑭ Heater fermentation + steam
- ⑮ Heater fermentation + stirring operation + steam
- ⑯ Heater fermentation + stirring operation + steam (no boiling control)
- ⑰ State of humidity within heating chamber  
 X: Short humidity                      X: Short humidity  
 Humidity control by equipment is possible.  
 Optimum control of humidity within heating chamber by equipment is possible.
- ⑱ State of temperature within heating chamber  
 Δ: To maintain temperature within heating chamber is difficult.  
 Δ - O: Two or more heating sources + boiling energy makes it difficult to maintain uniform temperature within heating chamber.  
 O: Optimum control of temperature within heating chamber by equipment is possible.  
 ◎: Because of no boiling control, further optimum control of temperature within heating chamber by equipment is possible.

⑬ Evaluation

- Δ: To maintain proper humidity and proper temperature within heating chamber constant is difficult.
- Δ: When using a cooking apparatus, use of this method is normal.
- : Because of arbitrary setting, control of humidity, temperature and time on cooking apparatus side is possible.
- ◎: Because of arbitrary setting, optimum and uniform control of humidity, temperature and time on cooking apparatus side is possible.

Fig 6

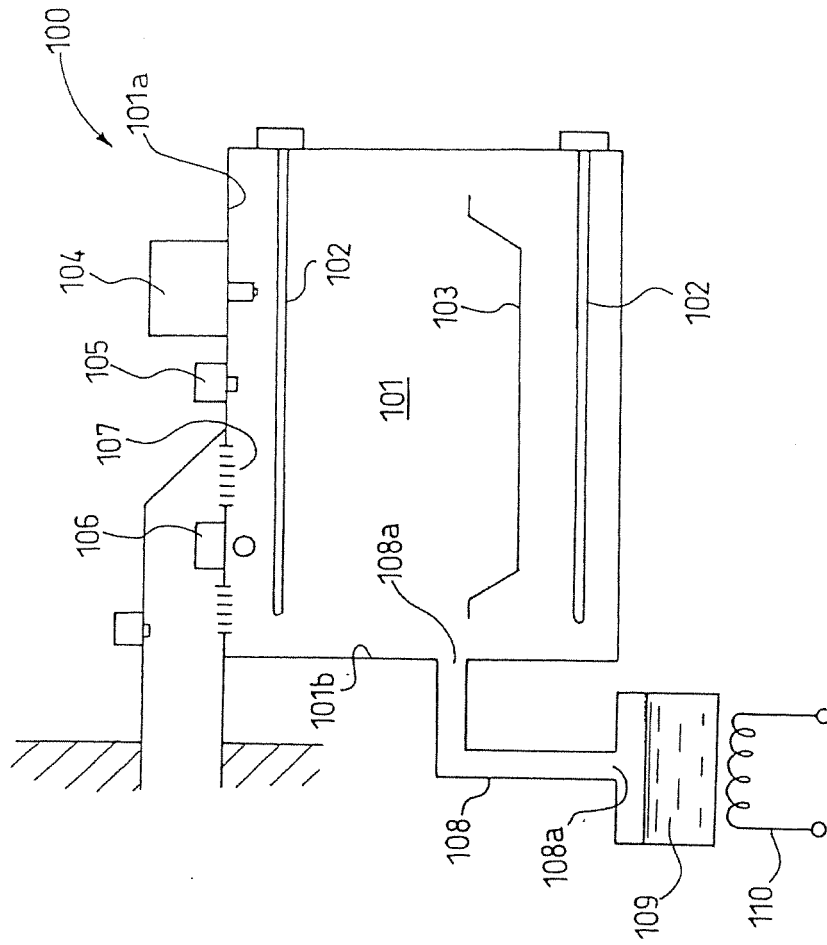

## INTERNATIONAL SEARCH REPORT

International application No.

PCT/JP2005/007521

A. CLASSIFICATION OF SUBJECT MATTER Int.Cl. <sup>7</sup> F24C1/00, 7/02, 15/32		
According to International Patent Classification (IPC) or to both national classification and IPC		
B. FIELDS SEARCHED		
Minimum documentation searched (classification system followed by classification symbols) Int.Cl. <sup>7</sup> F24C1/00, 7/02, 15/32		
Documentation searched other than minimum documentation to the extent that such documents are included in the fields searched Jitsuyo Shinan Koho 1922-1996 Jitsuyo Shinan Toroku Koho 1996-2005 Kokai Jitsuyo Shinan Koho 1971-2005 Toroku Jitsuyo Shinan Koho 1994-2005		
Electronic data base consulted during the international search (name of data base and, where practicable, search terms used)		
C. DOCUMENTS CONSIDERED TO BE RELEVANT		
Category*	Citation of document, with indication, where appropriate, of the relevant passages	Relevant to claim No.
Y	JP 56-42020 A (Hitachi Netsukigu Kabushiki Kaisha), 20 April, 1981 (20.04.81), Full text (Family: none)	1-7
Y	JP 2004-61011 A (Matsushita Electric Industrial Co., Ltd.), 26 February, 2004 (26.02.04), Full text (Family: none)	1-4, 6, 7
<input checked="" type="checkbox"/> Further documents are listed in the continuation of Box C.		<input type="checkbox"/> See patent family annex.
* Special categories of cited documents:		
"A"	document defining the general state of the art which is not considered to be of particular relevance	"T" later document published after the international filing date or priority date and not in conflict with the application but cited to understand the principle or theory underlying the invention
"E"	earlier application or patent but published on or after the international filing date	"X" document of particular relevance; the claimed invention cannot be considered novel or cannot be considered to involve an inventive step when the document is taken alone
"L"	document which may throw doubts on priority claim(s) or which is cited to establish the publication date of another citation or other special reason (as specified)	"Y" document of particular relevance; the claimed invention cannot be considered to involve an inventive step when the document is combined with one or more other such documents, such combination being obvious to a person skilled in the art
"O"	document referring to an oral disclosure, use, exhibition or other means	"&" document member of the same patent family
"P"	document published prior to the international filing date but later than the priority date claimed	
Date of the actual completion of the international search 11 July, 2005 (11.07.05)	Date of mailing of the international search report 26 July, 2005 (26.07.05)	
Name and mailing address of the ISA/ Japanese Patent Office	Authorized officer	
Facsimile No.	Telephone No.	

Form PCT/ISA/210 (second sheet) (January 2004)

## INTERNATIONAL SEARCH REPORT

International application No.

PCT/JP2005/007521

C (Continuation). DOCUMENTS CONSIDERED TO BE RELEVANT		
Category*	Citation of document, with indication, where appropriate, of the relevant passages	Relevant to claim No.
Y	JP 2004-20005 A (Matsushita Electric Industrial Co., Ltd.), 22 January, 2004 (22.01.04), Full text & US 2003-230569 A1 & EP 1372358 A1 & CN 1469081 A	1
Y	JP 60-29838 Y2 (Toshiba Corp.), 07 September, 1985 (07.09.85), Full text (Family: none)	1
Y	Microfilm of the specification and drawings annexed to the request of Japanese Utility Model Application No. 78123/1978 (Laid-open No. 179579/1979) (Hitachi Netsukigu Kabushiki Kaisha), 19 December, 1979 (19.12.79), Full text (Family: none)	1
Y	Microfilm of the specification and drawings annexed to the request of Japanese Utility Model Application No. 157219/1977 (Laid-open No. 82088/1979) (Hitachi Netsukigu Kabushiki Kaisha), 11 June, 1979 (11.06.79), Full text (Family: none)	1
Y	Microfilm of the specification and drawings annexed to the request of Japanese Utility Model Application No. 5671/1987 (Laid-open No. 114235/1988) (Hitachi Netsukigu Kabushiki Kaisha), 22 July, 1988 (22.07.88), Full text (Family: none)	7
Y	JP 59-1930 A (Sanyo Electric Co., Ltd.), 07 January, 1984 (07.01.84), Full text (Family: none)	7
Y	JP 2003-50015 A (Sharp Corp.), 21 February, 2003 (21.02.03), Full text (Family: none)	1
Y	JP 63-105327 A (Hitachi Netsukigu Kabushiki Kaisha), 10 May, 1988 (10.05.88), Full text (Family: none)	4

Form PCT/ISA/210 (continuation of second sheet) (January 2004)

EP 1 741 987 A1

INTERNATIONAL SEARCH REPORT

International application No.

PCT/JP2005/007521

C (Continuation). DOCUMENTS CONSIDERED TO BE RELEVANT		
Category*	Citation of document, with indication, where appropriate, of the relevant passages	Relevant to claim No.
Y	JP 58-32081 Y2 (Tokyo Shibaura Electric Co., Ltd.), 16 July, 1983 (16.07.83), Full text (Family: none)	1-7
A	JP 2002-512010 A (Yung Simon), 23 April, 2002 (23.04.02), Full text & WO 99/53767 A1                      & US 6035763 A1 & US 6347578 B1                      & US 2002-83845 A1 & EP 1071337 A                      & DE 69903530 T & AU 3614499 A                      & CA 2328964 A & CN 1323163 T                      & AU 765764 B	1-7

Form PCT/ISA/210 (continuation of second sheet) (January 2004)

**REFERENCES CITED IN THE DESCRIPTION**

*This list of references cited by the applicant is for the reader's convenience only. It does not form part of the European patent document. Even though great care has been taken in compiling the references, errors or omissions cannot be excluded and the EPO disclaims all liability in this regard.*

**Patent documents cited in the description**

- JP 58031931 A [0004]