



(12) **EUROPEAN PATENT APPLICATION**

(88) Date of publication A3:
15.12.1999 Bulletin 1999/50

(51) Int Cl.⁶: **H01L 21/31, H01L 21/762,
H01L 21/763**

(43) Date of publication A2:
14.04.1999 Bulletin 1999/15

(21) Application number: **98307803.1**

(22) Date of filing: **25.09.1998**

(84) Designated Contracting States:
**AT BE CH CY DE DK ES FI FR GB GR IE IT LI LU
MC NL PT SE**
Designated Extension States:
AL LT LV MK RO SI

(72) Inventors:
• **Gruening, Ulrike**
Wappingers Falls, N.Y. 12590 (US)
• **Beintner, Jochen**
Wappingers Falls, N.Y. 12590 (US)
• **Radens, Carl**
Poughkeepsie, N.Y. 12603 (US)

(30) Priority: **26.09.1997 US 938196**

(71) Applicants:
• **SIEMENS AKTIENGESELLSCHAFT**
80333 München (DE)
• **International Business Machines Corporation**
Armonk, N.Y. 10504 (US)

(74) Representative: **O'Connell, David Christopher**
Haseltine Lake & Co.,
Imperial House,
15-19 Kingsway
London WC2B 6UD (GB)

(54) **Buffer layer for improving control of layer thickness**

(57) A pad layer disposed on a semiconductor substrate 102 and a buffer layer 108 disposed within the pad layer such that the pad layer is divided into a dielectric layer 106 below the buffer layer and a mask layer 110 above the buffer layer. A method of forming layers with uniform planarity and thickness on a semiconductor chip includes the steps of providing a substrate having

a thermal pad 106 formed thereon, forming a dielectric layer 106 on the thermal pad, forming a buffer layer 108 on the dielectric layer wherein the buffer layer is made from a different material than the dielectric layer and forming a mask layer 110 on the buffer layer wherein the buffer layer is made from a different material than the mask layer.

FIG. 2

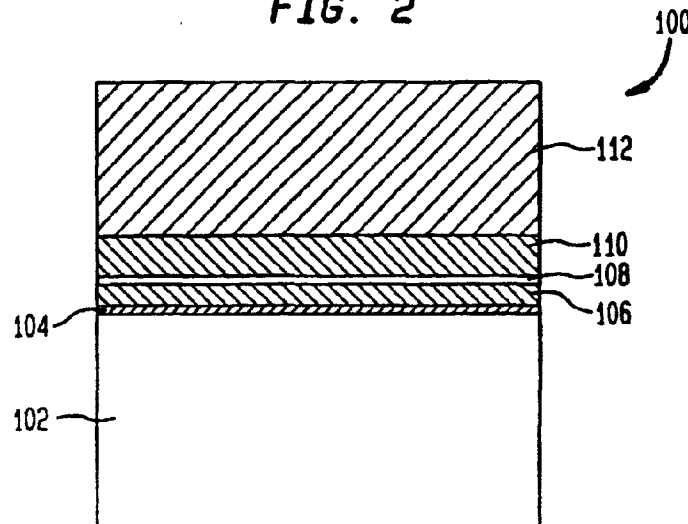



European Patent
Office

EUROPEAN SEARCH REPORT

Application Number
EP 98 30 7803

DOCUMENTS CONSIDERED TO BE RELEVANT			
Category	Citation of document with indication, where appropriate, of relevant passages	Relevant to claim	CLASSIFICATION OF THE APPLICATION (Int.Cl.6)
P, X	WO 97 38442 A (ADVANCED MICRO DEVICES INC) 16 October 1997 (1997-10-16) * page 5, line 35 - page 8, line 20; figures 1-8 * ---	1,6,8, 11-14, 20,21	H01L21/31 H01L21/762 H01L21/763
X	WO 96 02070 A (NAT SEMICONDUCTOR CORP) 25 January 1996 (1996-01-25) * page 6, line 7 - page 10, line 16; figures 1-9 * ---	1,6,8, 11-16, 20,21	
X	US 4 666 556 A (FULTON INGE G ET AL) 19 May 1987 (1987-05-19) * column 6, line 33 - column 8, line 60; figures 3-8 * ---	1,6,8, 11-14, 20,21	
X	EP 0 450 091 A (OKI ELECTRIC IND CO LTD) 9 October 1991 (1991-10-09) * column 4, line 30 - column 5, line 51; figure 1 * ---	1,3,6-8, 12-14, 17,21	TECHNICAL FIELDS SEARCHED (Int.Cl.6) H01L
A	EP 0 764 981 A (SIEMENS AG ;IBM (US)) 26 March 1997 (1997-03-26) * the whole document * -----	1-21	
The present search report has been drawn up for all claims			
Place of search MUNICH		Date of completion of the search 26 October 1999	Examiner Wolff, G
CATEGORY OF CITED DOCUMENTS X : particularly relevant if taken alone Y : particularly relevant if combined with another document of the same category A : technological background O : non-written disclosure P : intermediate document		T : theory or principle underlying the invention E : earlier patent document, but published on, or after the filing date D : document cited in the application L : document cited for other reasons ----- & : member of the same patent family, corresponding document	

EPO FORM 1503 03 82 (P4/C01)

**ANNEX TO THE EUROPEAN SEARCH REPORT
ON EUROPEAN PATENT APPLICATION NO.**

EP 98 30 7803

This annex lists the patent family members relating to the patent documents cited in the above-mentioned European search report. The members are as contained in the European Patent Office EDP file on
The European Patent Office is in no way liable for these particulars which are merely given for the purpose of information.

26-10-1999

Patent document cited in search report	Publication date	Patent family member(s)	Publication date
WO 9738442 A	16-10-1997	NONE	
WO 9602070 A	25-01-1996	US 5581110 A US 5911109 A	03-12-1996 08-06-1999
US 4666556 A	19-05-1987	BR 8702320 A CA 1286572 A DE 3751732 D DE 3751732 T EP 0245622 A ES 2084575 T JP 62269335 A	17-02-1988 23-07-1991 18-04-1996 26-09-1996 19-11-1987 16-05-1996 21-11-1987
EP 0450091 A	09-10-1991	WO 9106119 A KR 140979 B US 5256592 A	02-05-1991 15-07-1998 26-10-1993
EP 0764981 A	26-03-1997	US 5643823 A JP 9219444 A US 5747866 A	01-07-1997 19-08-1997 05-05-1998

EPO FORM P0459

For more details about this annex : see Official Journal of the European Patent Office, No. 12/82