



US 20080071276A1

(19) **United States**

(12) **Patent Application Publication**

Ferree

(10) **Pub. No.: US 2008/0071276 A1**

(43) **Pub. Date: Mar. 20, 2008**

(54) **SPINAL ALIGNMENT SYSTEM AND RELATED METHODS**

Publication Classification

(75) Inventor: **Bret A. Ferree**, Cincinnati, OH (US)

(51) **Int. Cl.**
A61B 17/58 (2006.01)

(52) **U.S. Cl.** **606/61; 606/103**

Correspondence Address:
JONATHAN SPANGLER
NU VASIVE, INC.
4545 TOWNE CENTRE COURT
SAN DIEGO, CA 92121 (US)

(57) **ABSTRACT**

A spinal alignment system is disclosed and includes vertebral connectors, elongated elements that link the vertebral connectors, and fasteners that lock the elongated elements in position. An elongated element has at least one shaped end that is received by a coupling member of the connector. The shaped end permits the elongated element to be angularly moveable with respect to the coupling member until locked in place with a fastener received in the coupling member. The elongated element also preferably includes a length adjustment mechanism, such as a telescoping or threaded section to provide a desired length in conjunction with a desired degree of alignment. Various coupling mechanisms are disclosed to provide multiple degrees of freedom prior to fixation.

(73) Assignee: **Nu Vasive, Inc.**, San Diego, CA

(21) Appl. No.: **11/982,184**

(22) Filed: **Oct. 31, 2007**

Related U.S. Application Data

(60) Continuation of application No. 10/894,533, filed on Jul. 19, 2004, which is a division of application No. 10/105,971, filed on Mar. 25, 2002, now Pat. No. 6,802,844.

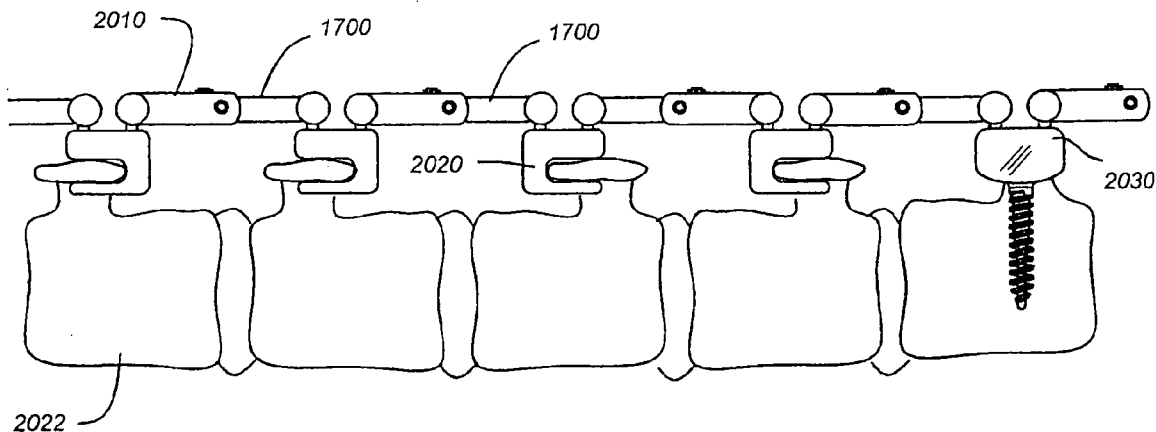

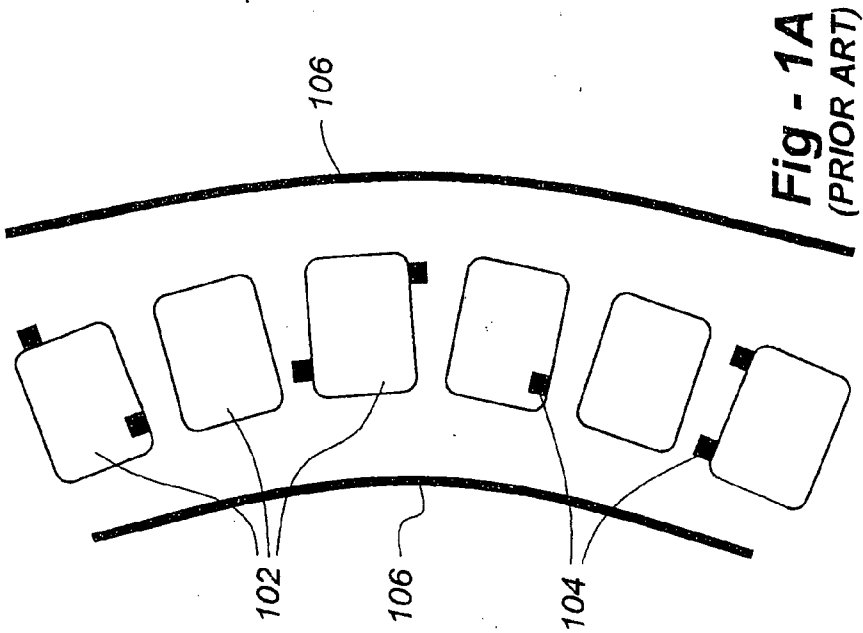
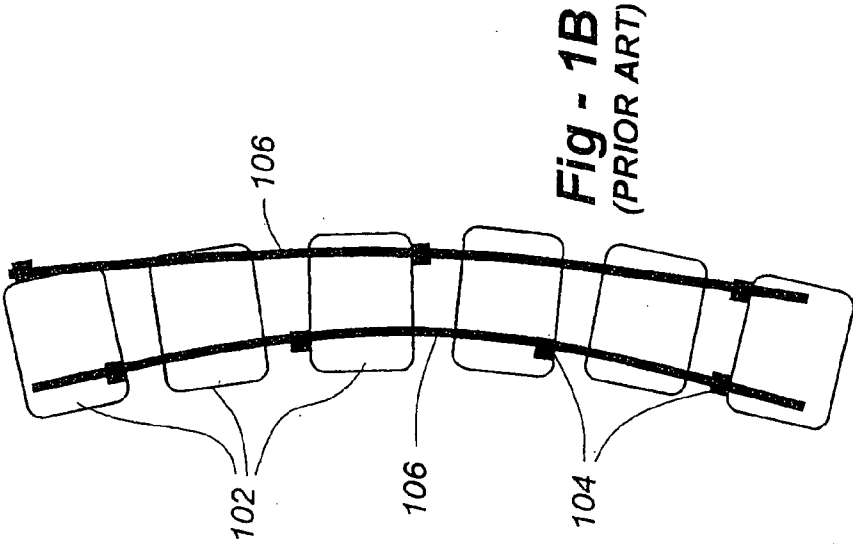
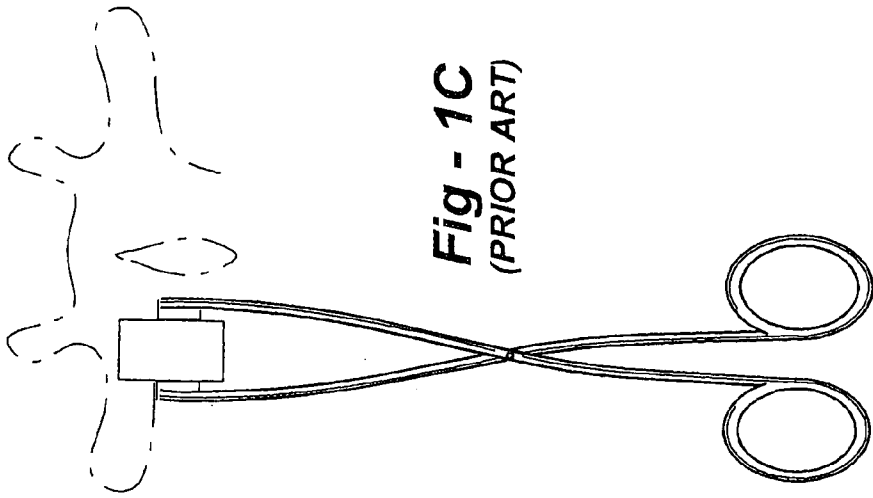

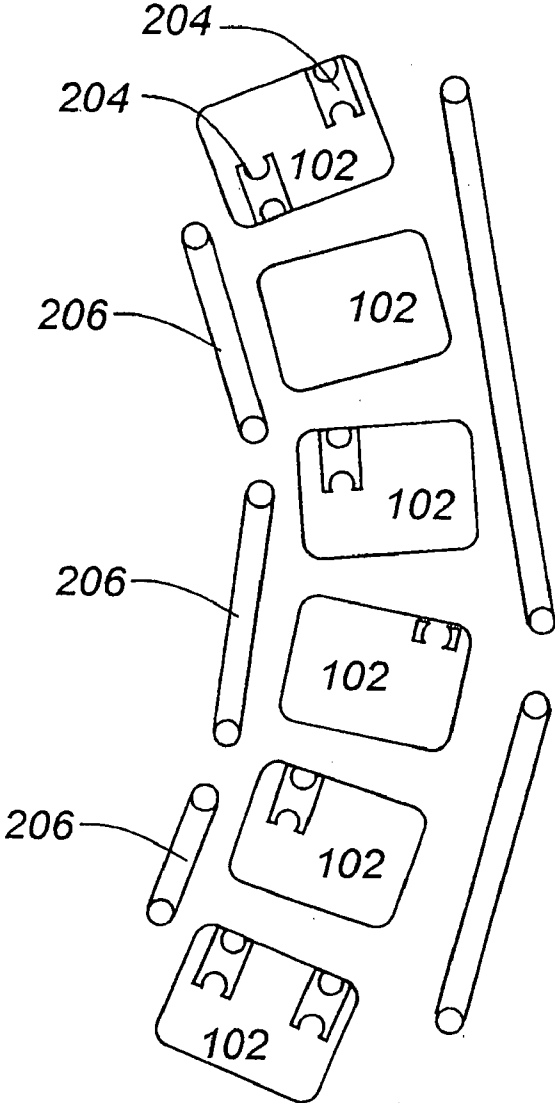

Fig - 2A

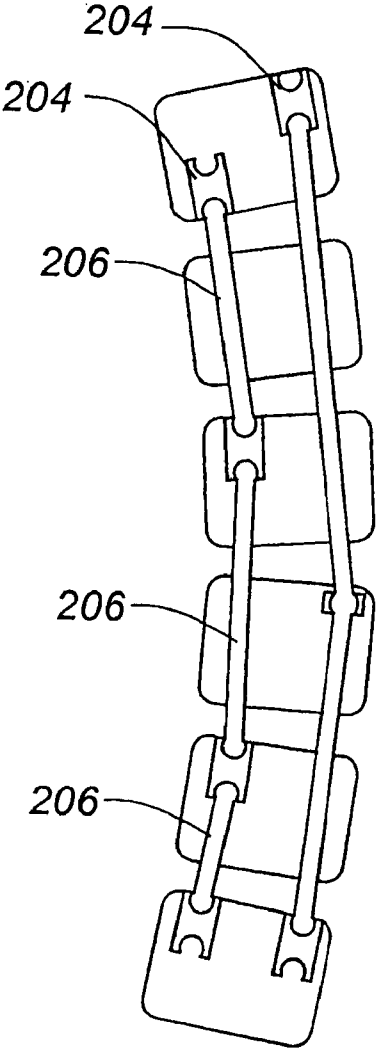

Fig - 2B

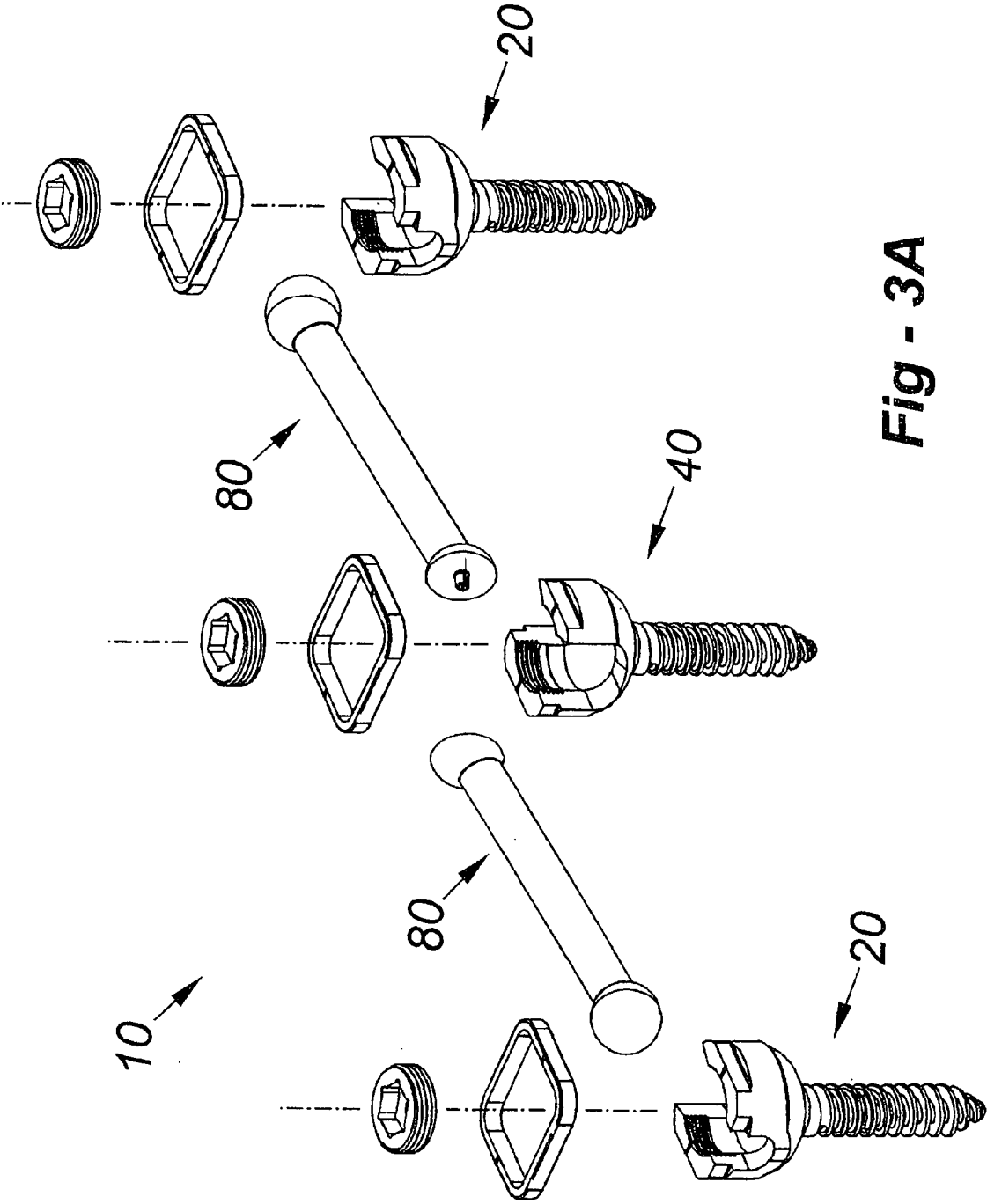

Fig - 3A

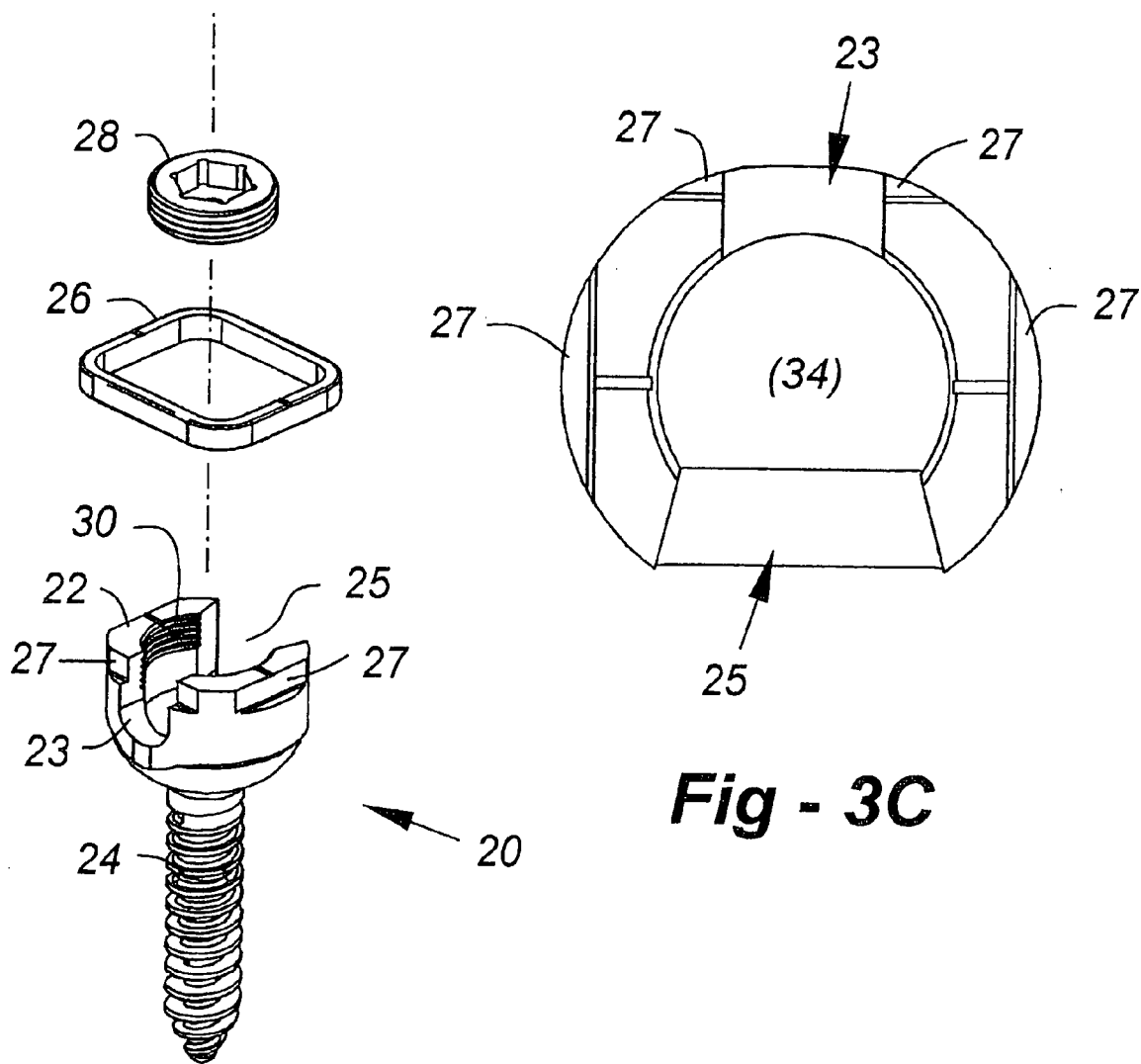

Fig - 3B

Fig - 3C

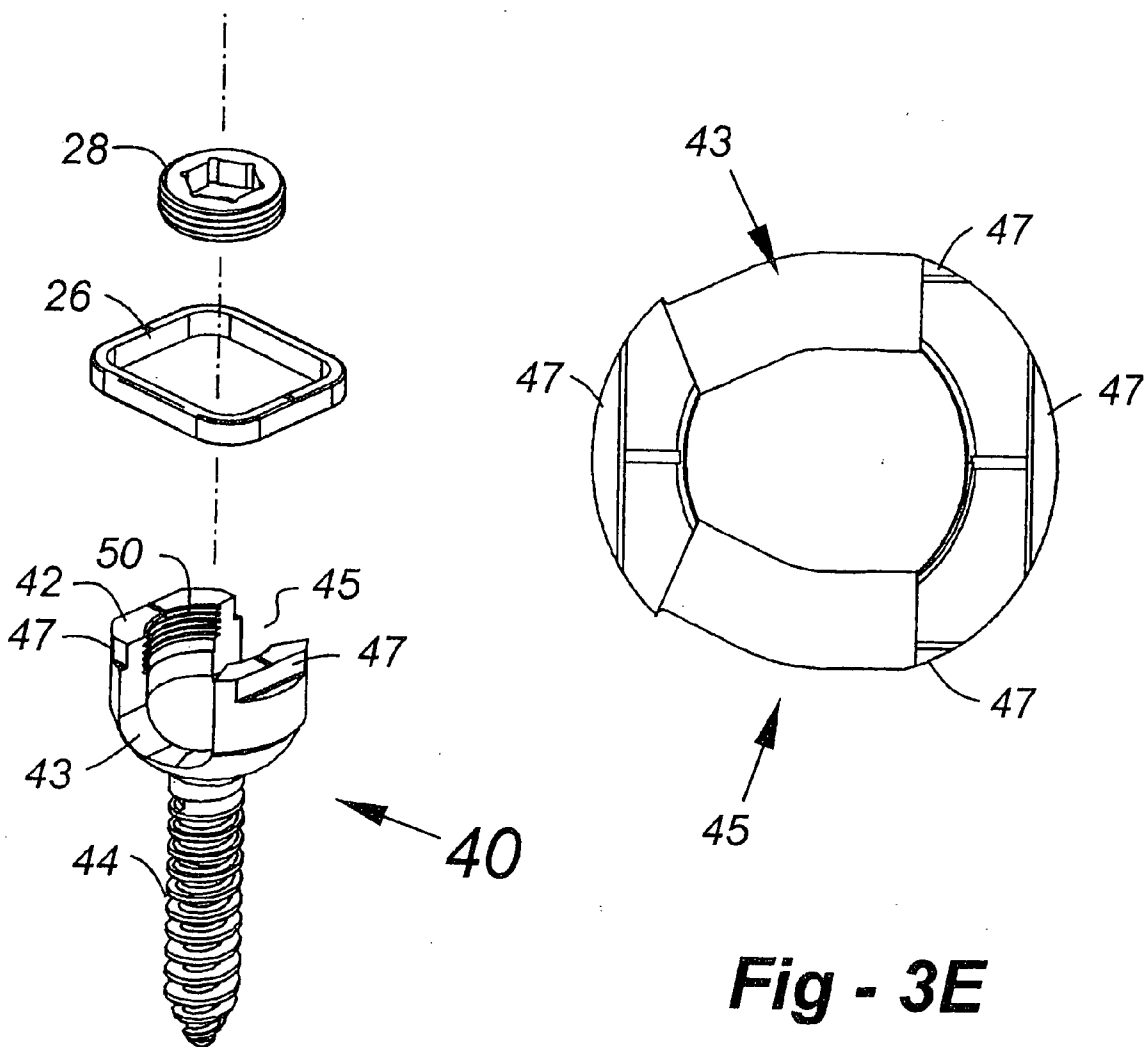

Fig - 3D

Fig - 3E

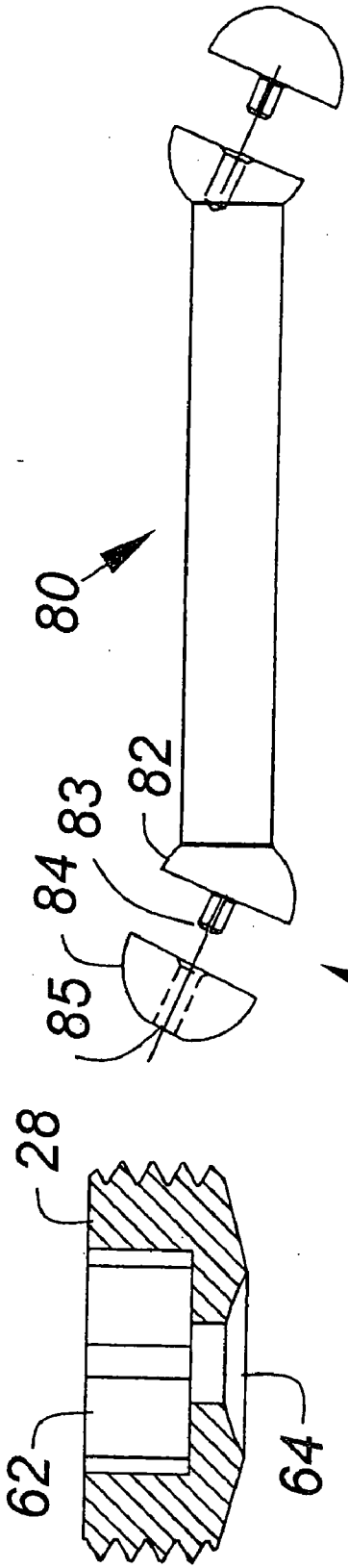

Fig - 3G

Fig - 3F

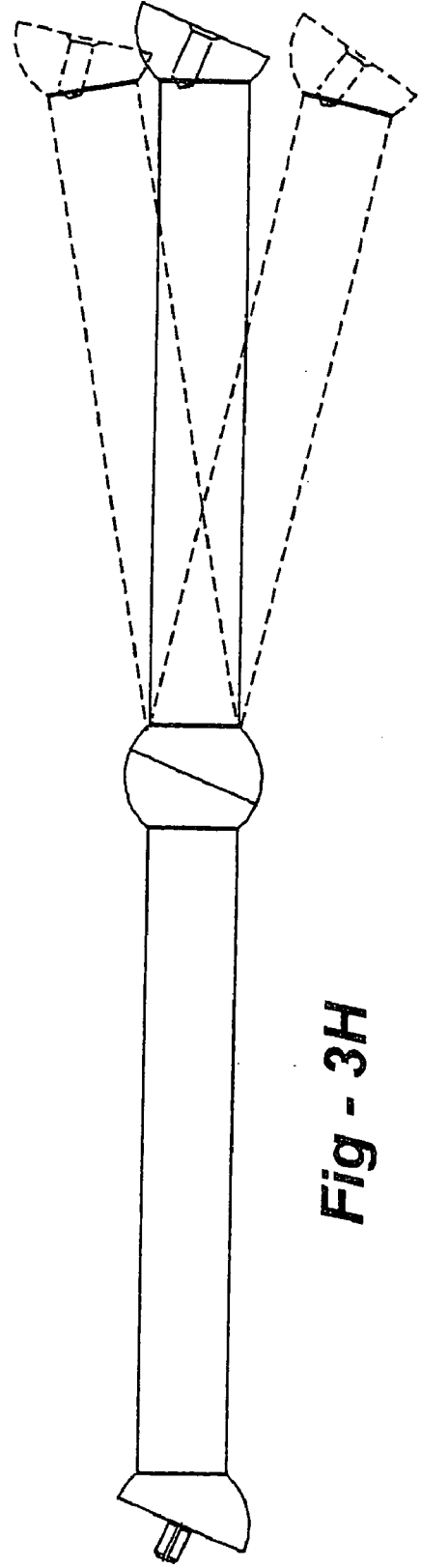

Fig - 3H

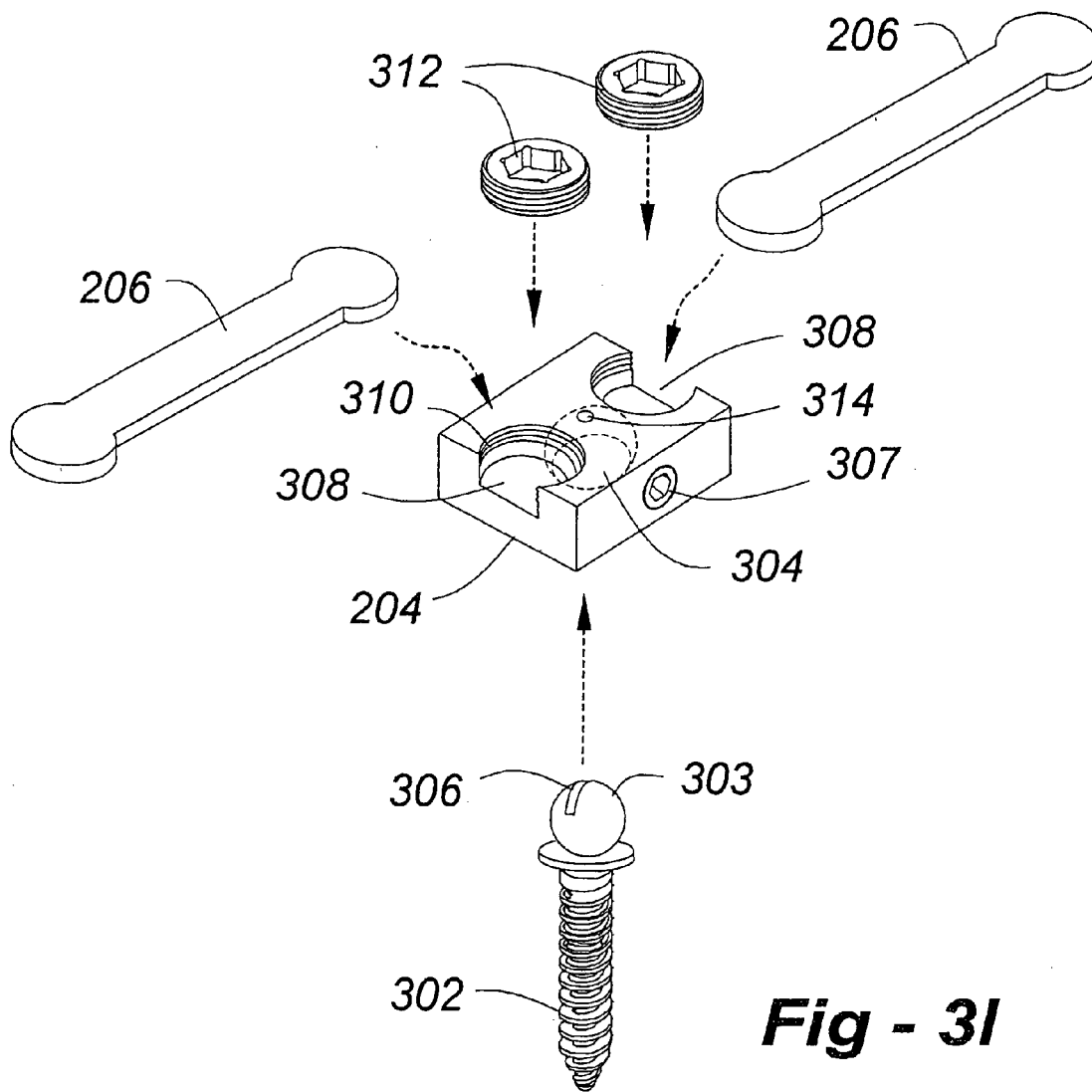

Fig - 31

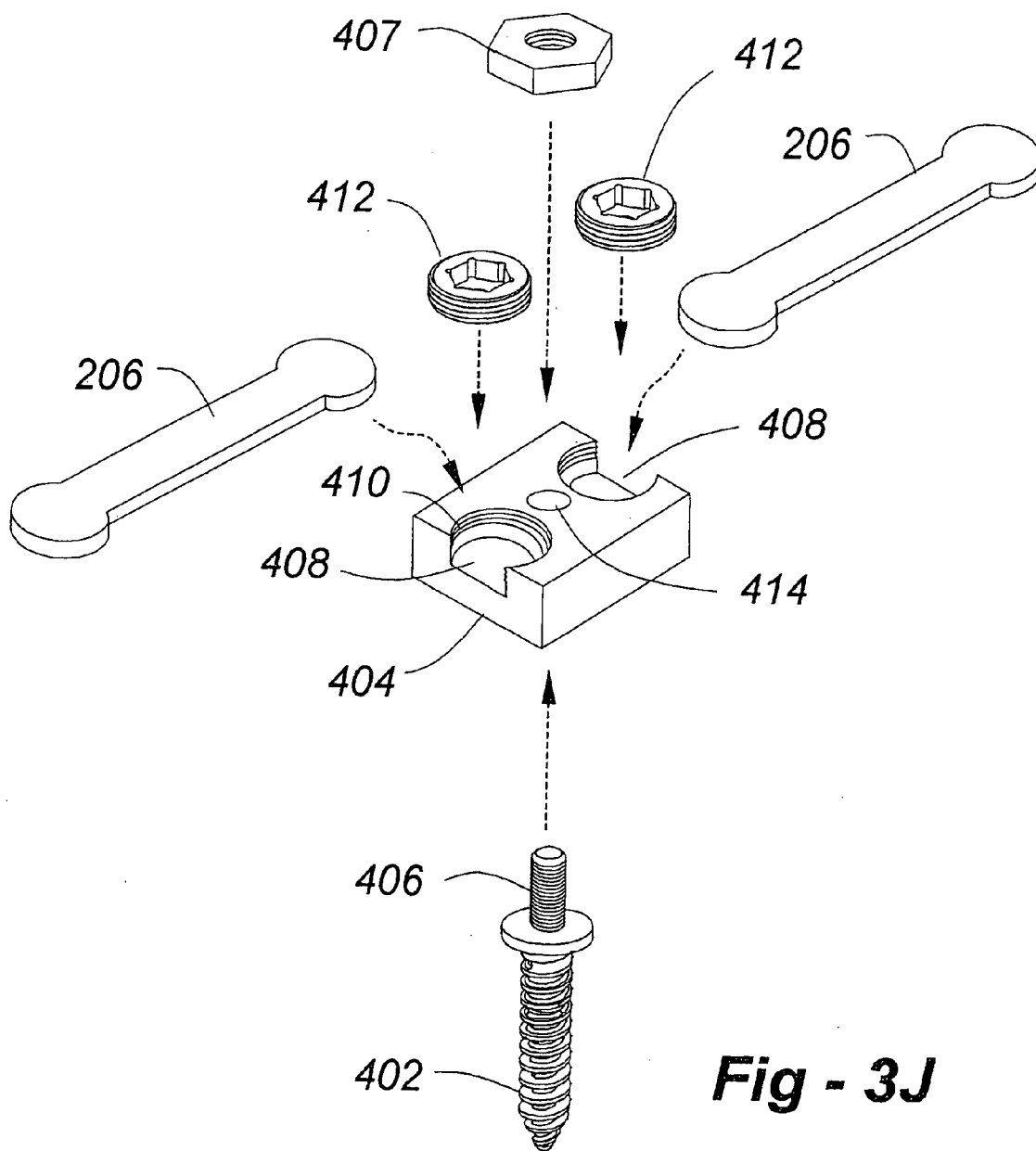

Fig - 3J

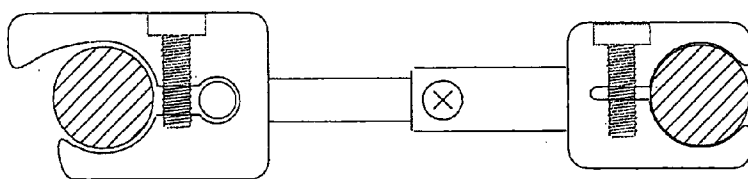

Fig - 3K

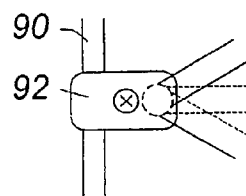

Fig - 3M

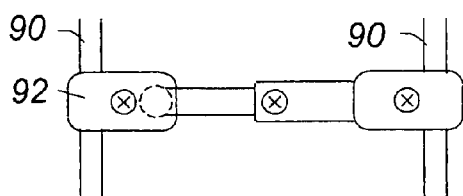

Fig - 3L



Fig - 3N

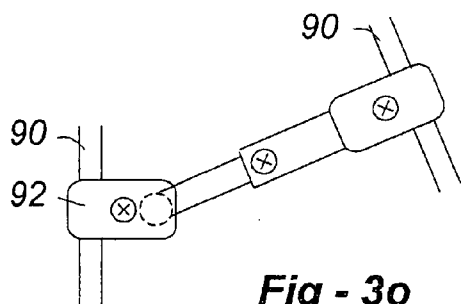

Fig - 3O

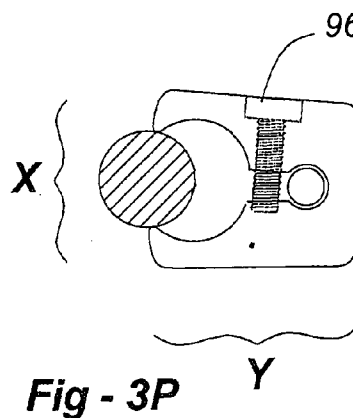

Fig - 3P

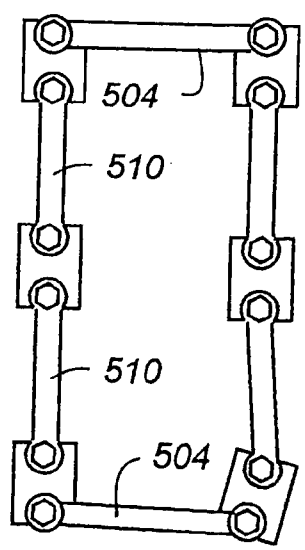
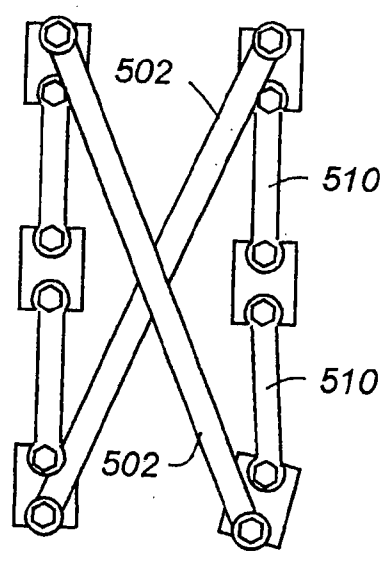
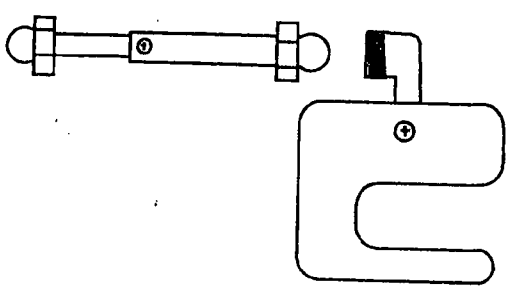
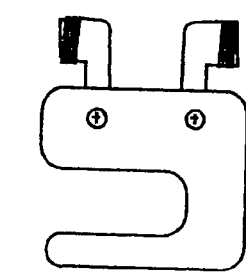
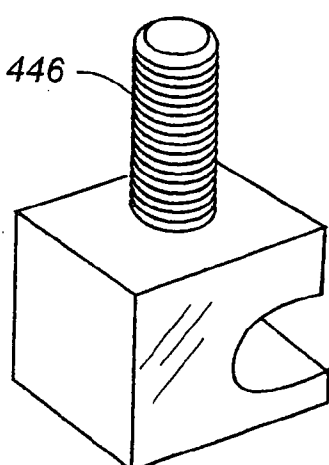
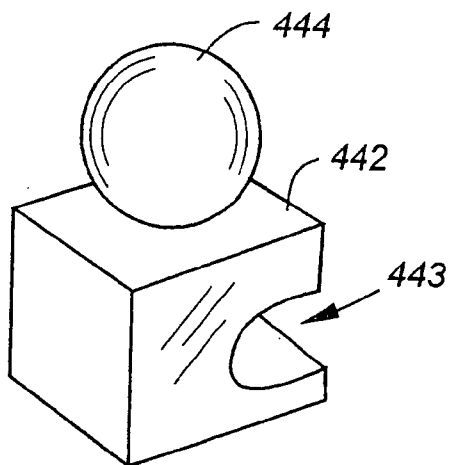
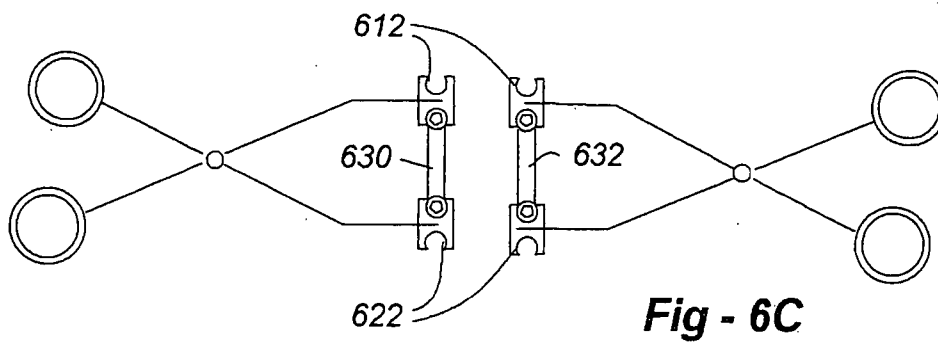
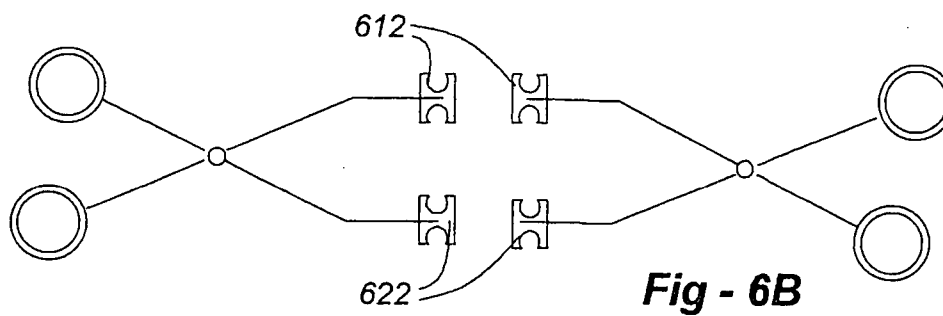
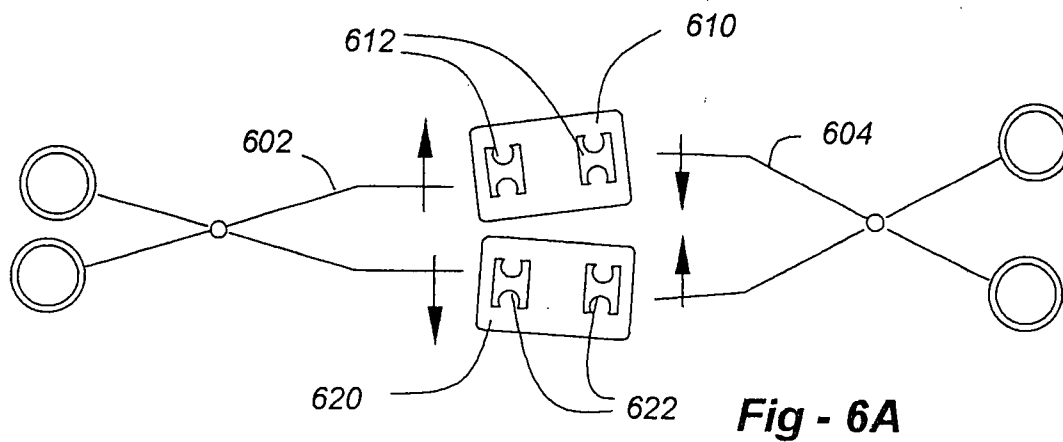

Fig - 5A

Fig - 5B



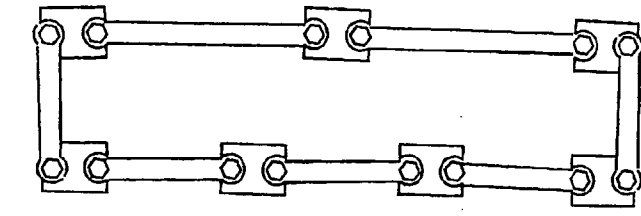

Fig - 7D

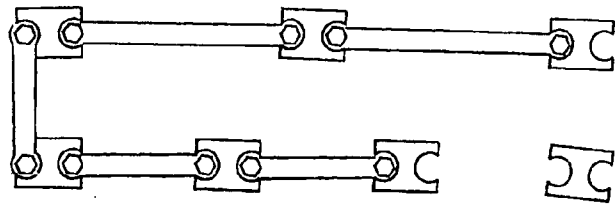

Fig - 7C

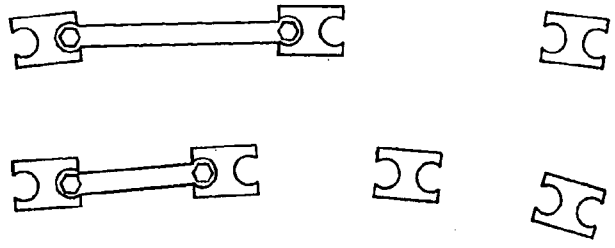

Fig - 7B

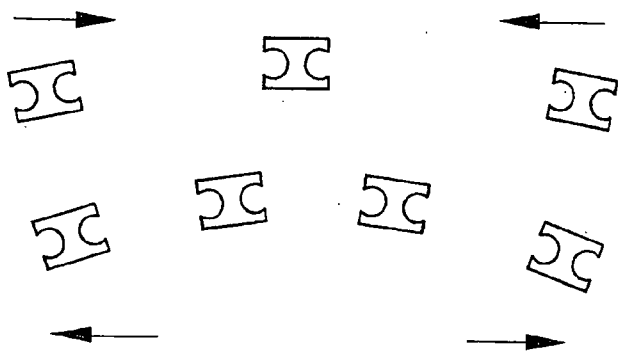
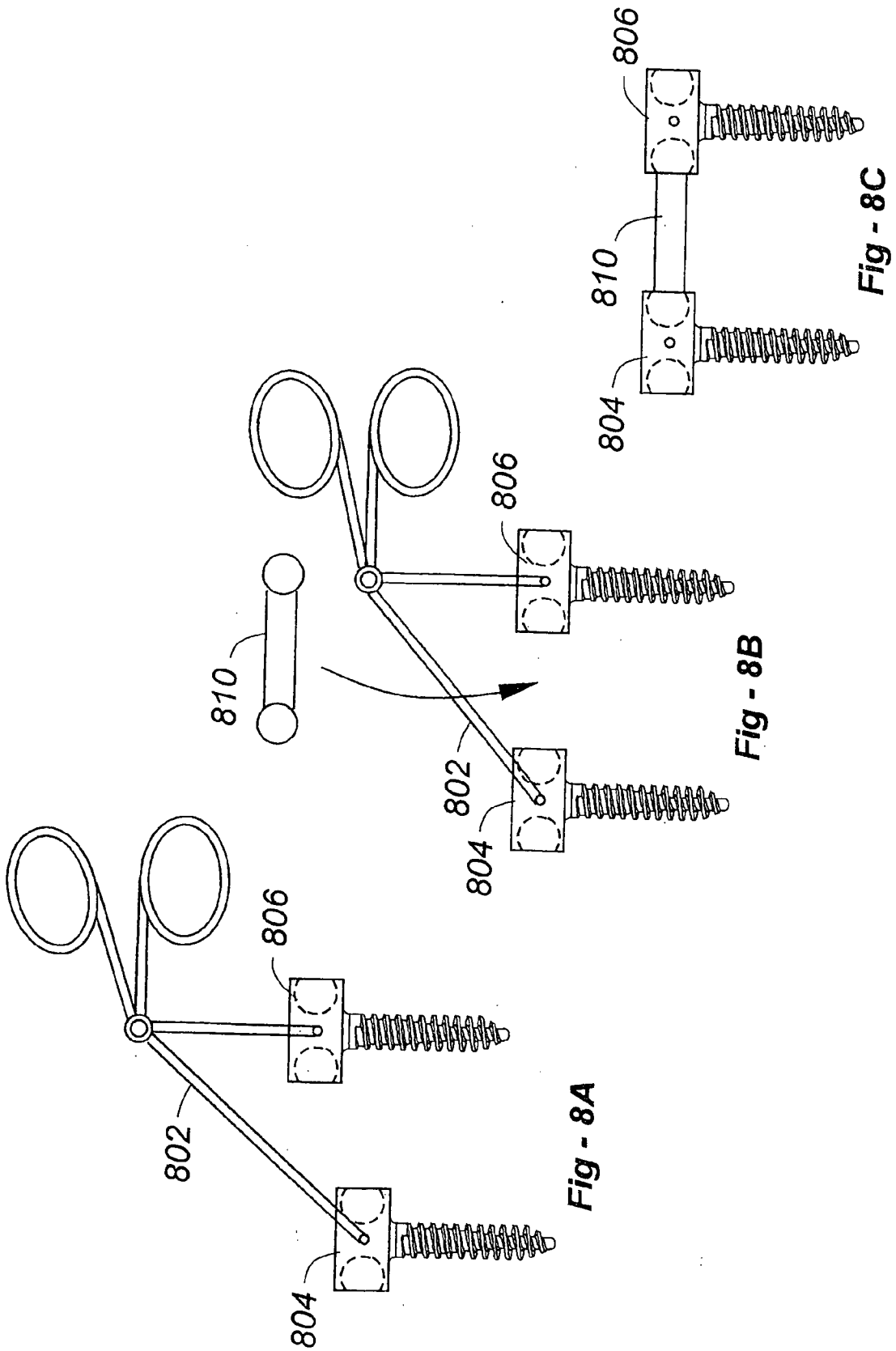
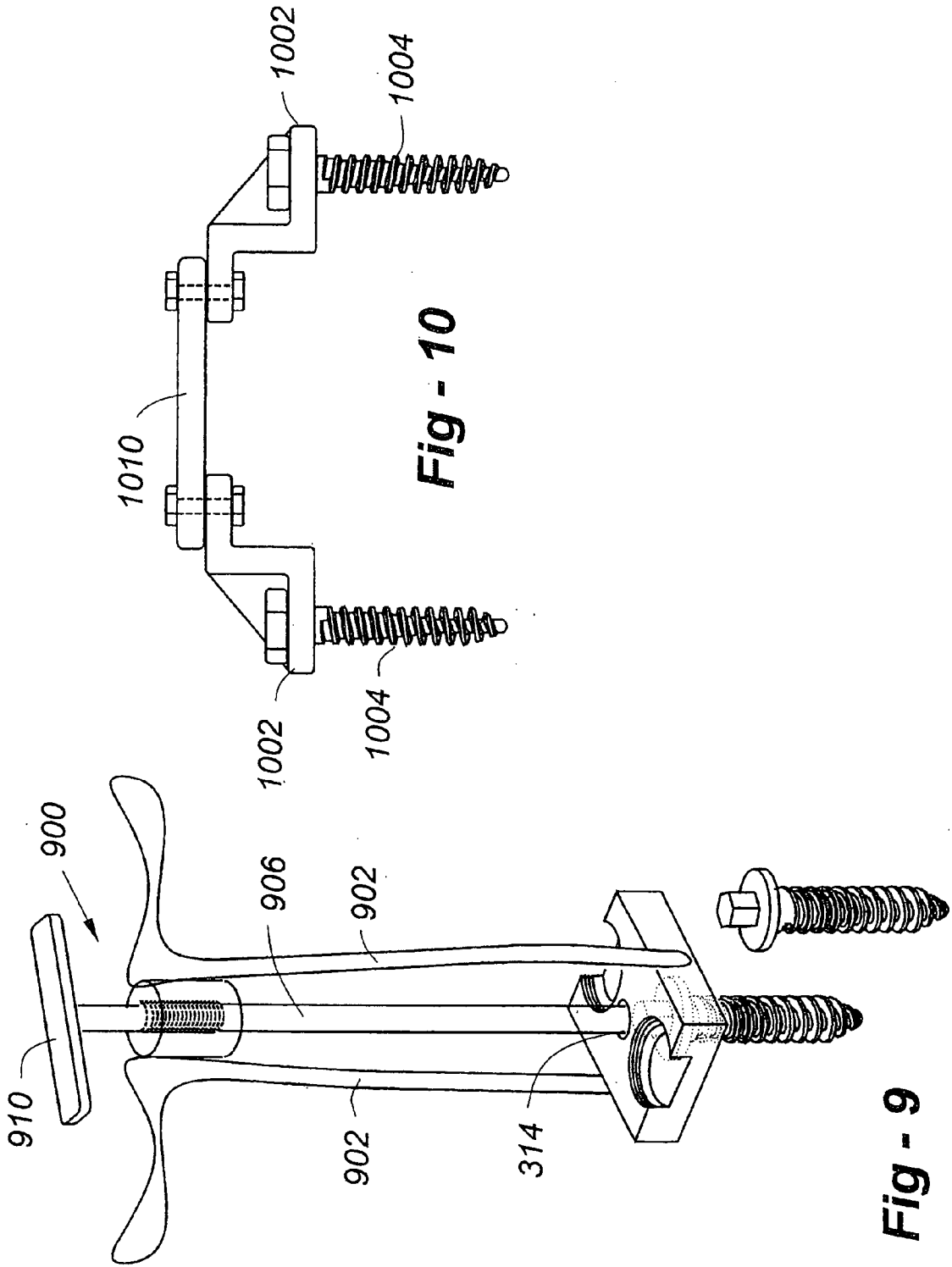

Fig - 7A





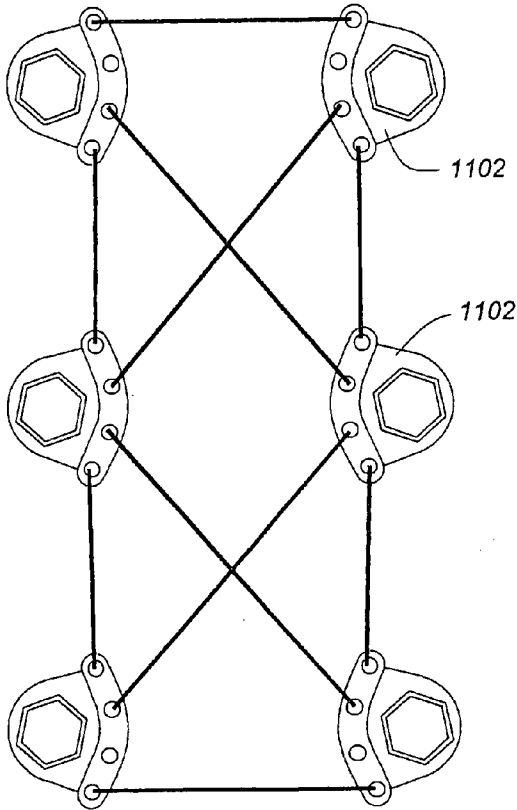

Fig - 11A

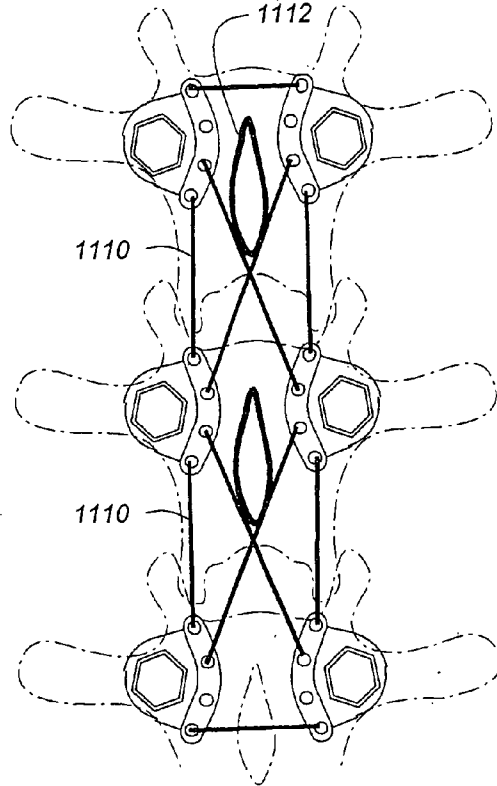

Fig - 11B

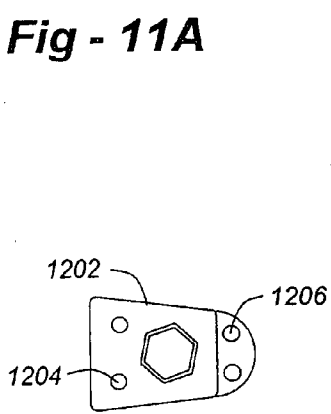

Fig - 12A

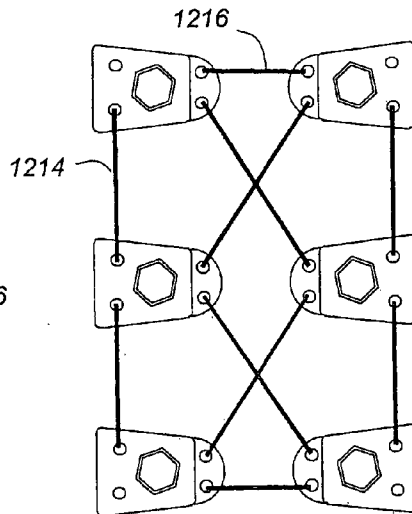

Fig - 12B

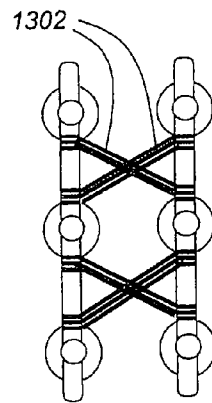

Fig - 13

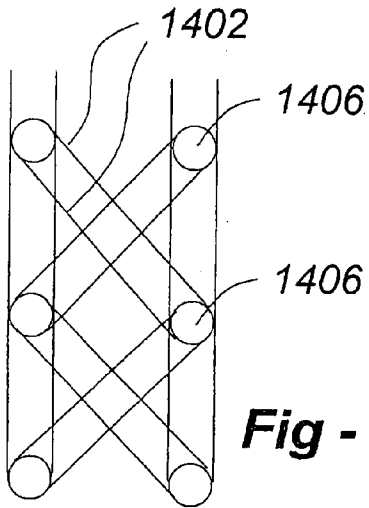

Fig - 14

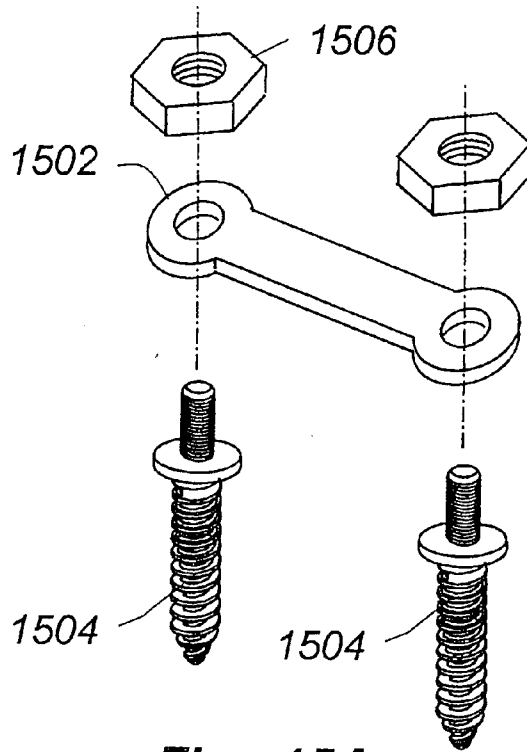

Fig - 15A

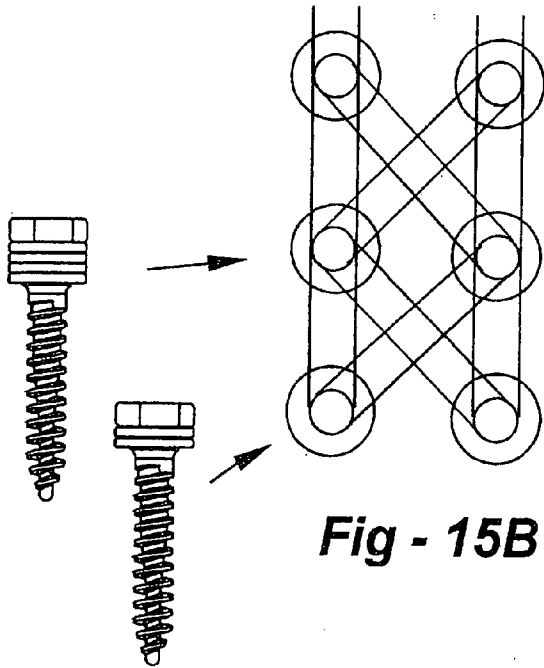

Fig - 15B

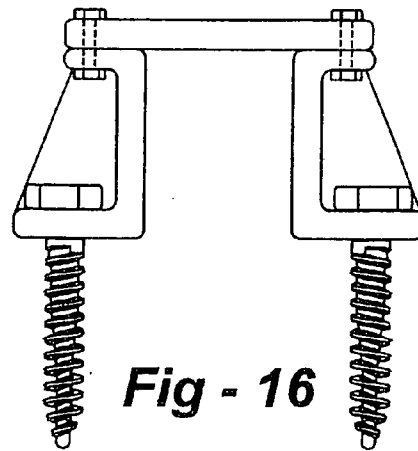

Fig - 16

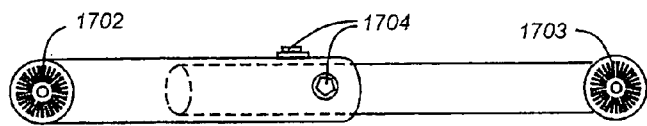

Fig - 17

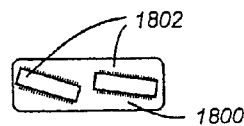

Fig - 18B

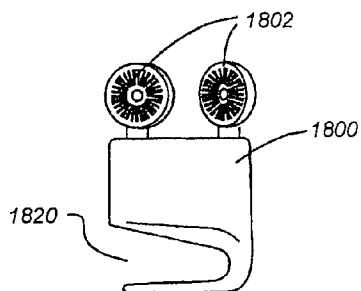

Fig - 18A

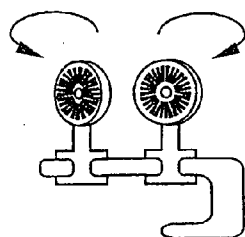

Fig - 18C

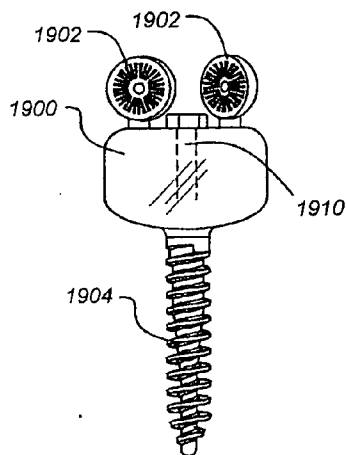

Fig - 19

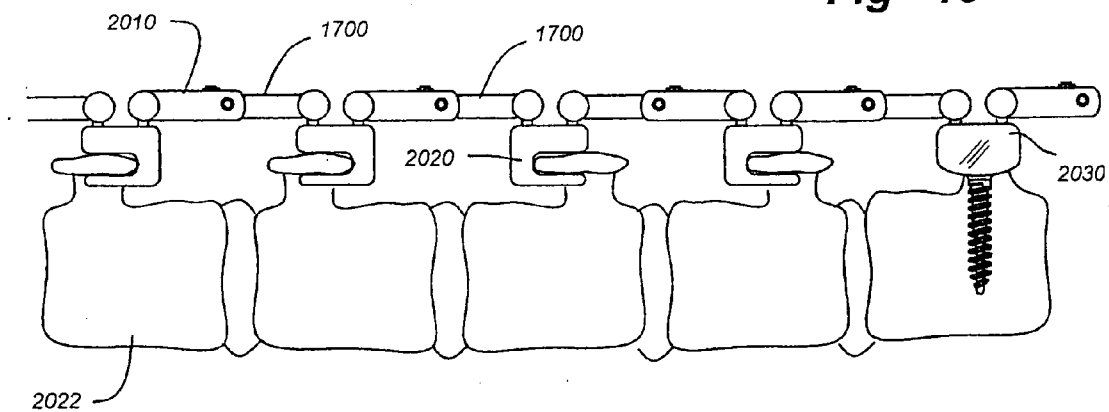
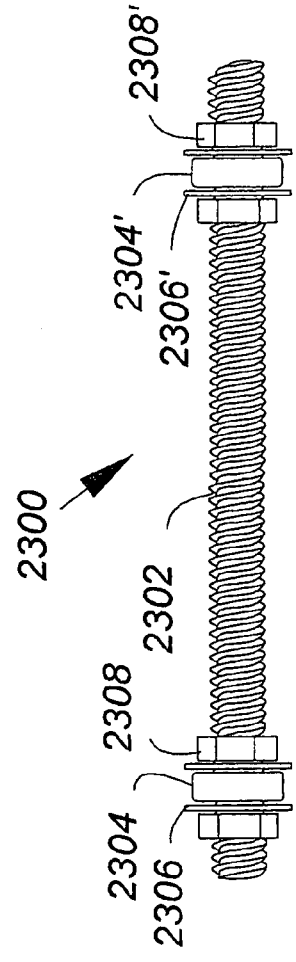
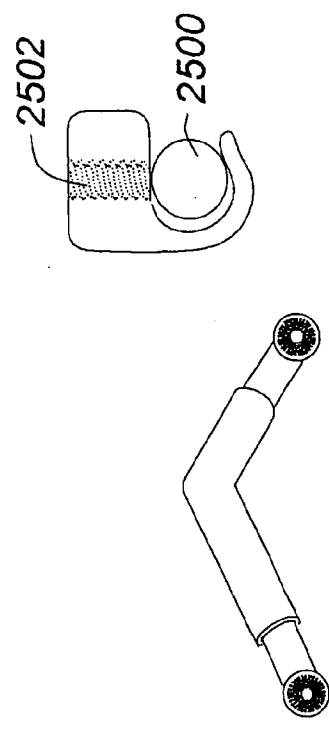
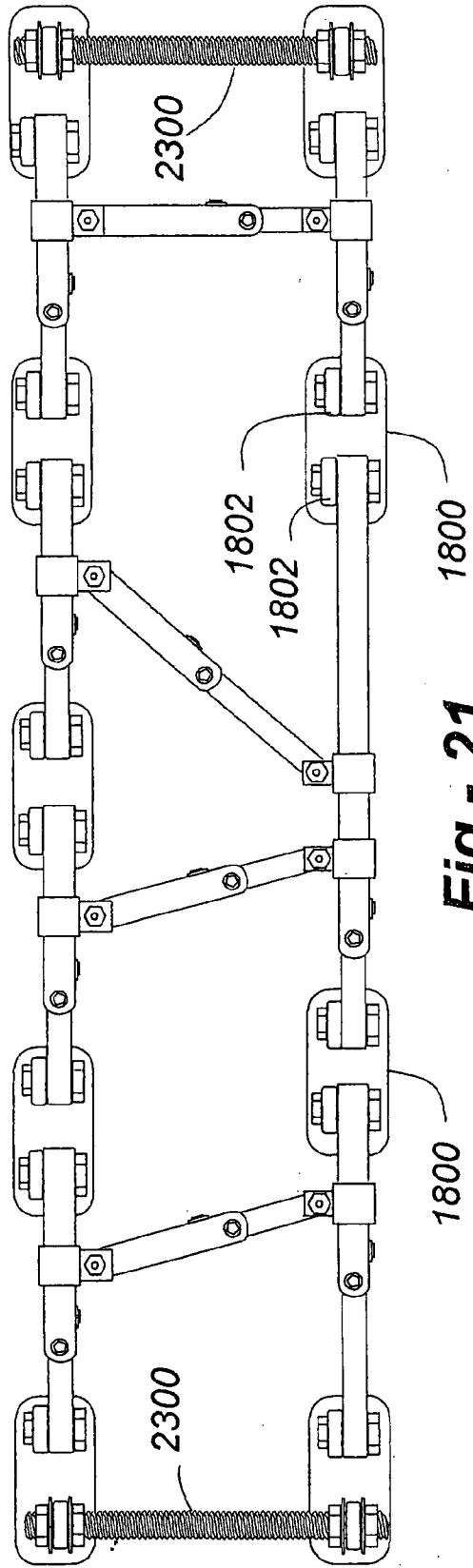
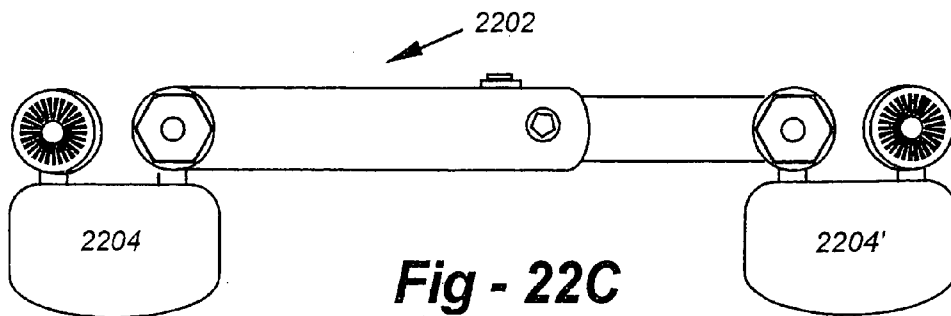
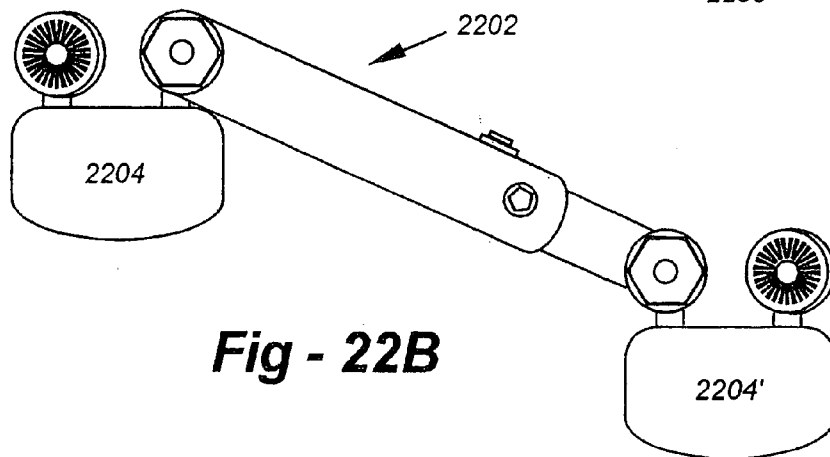
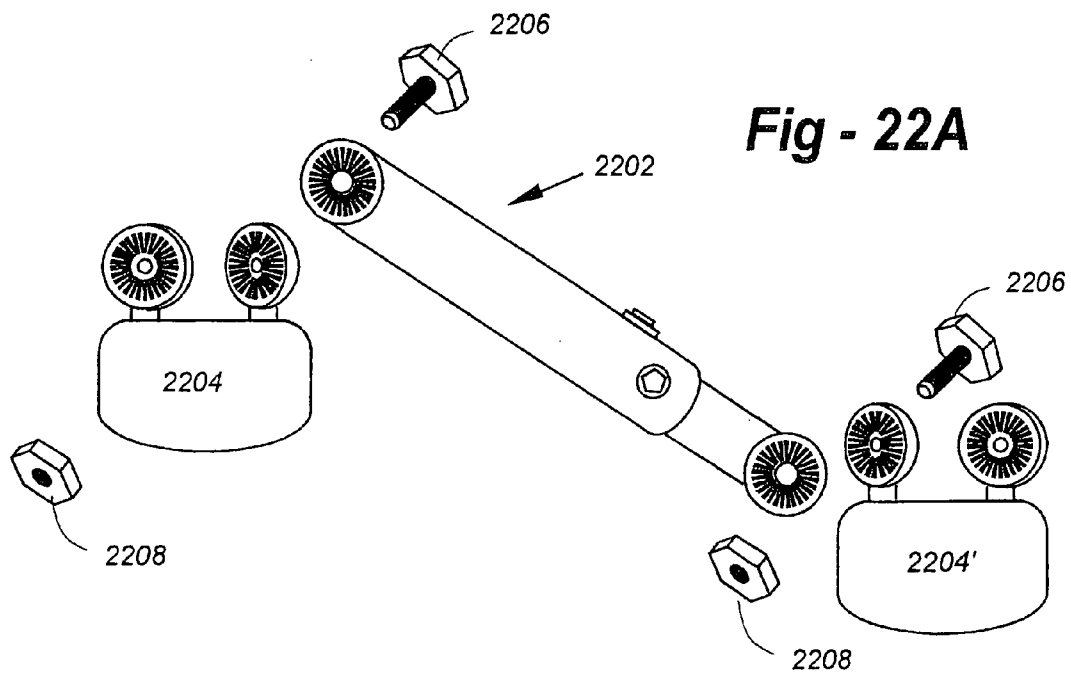

Fig - 20





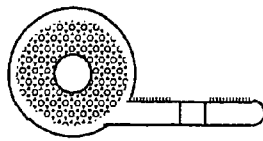
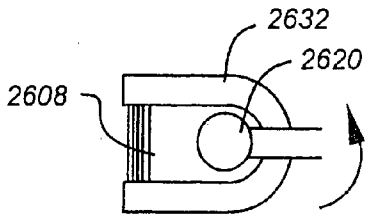
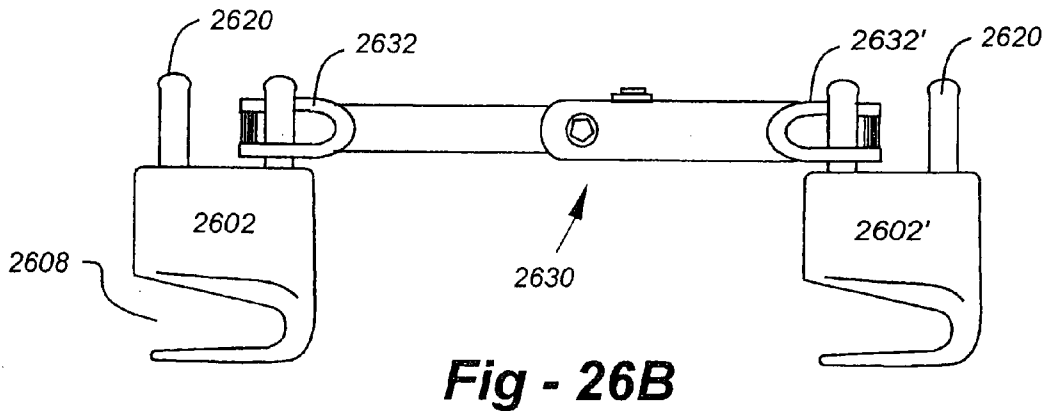
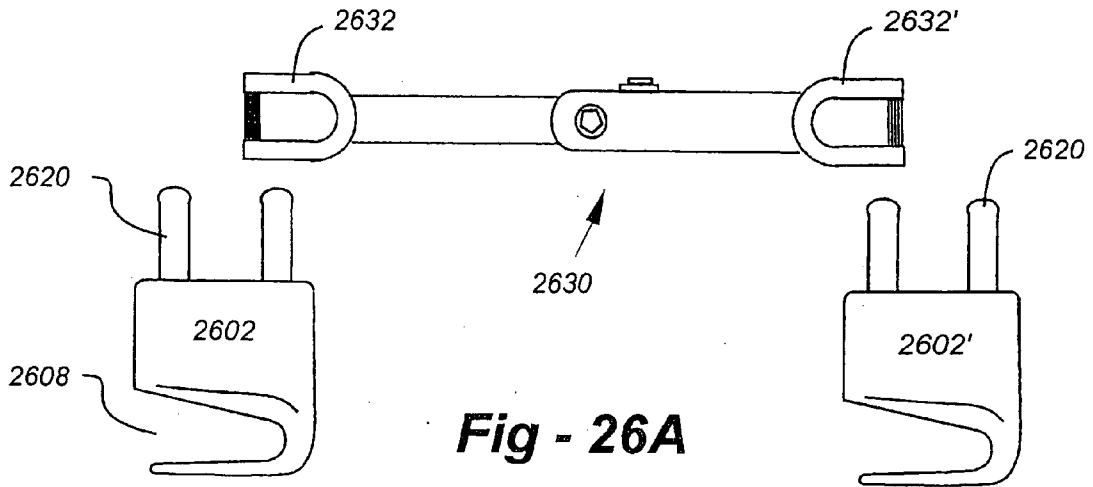

Fig - 27

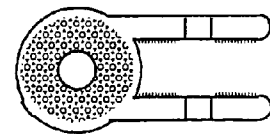
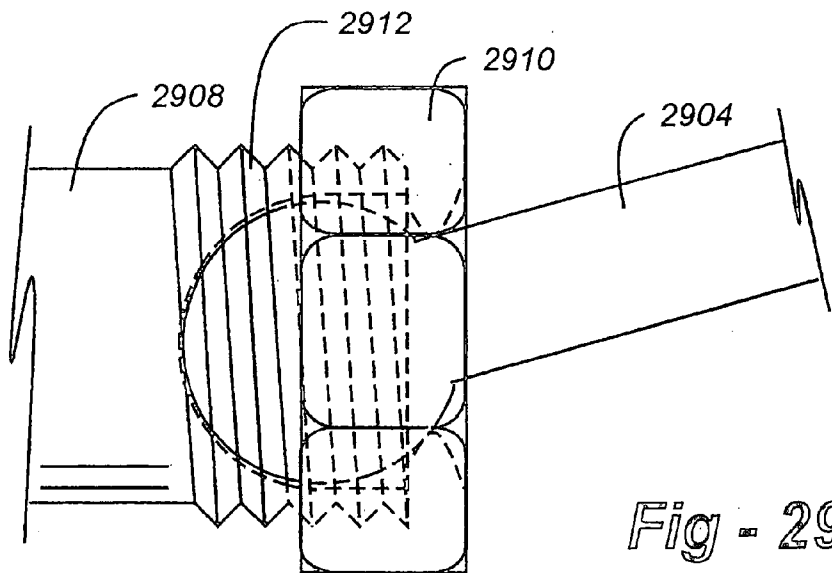
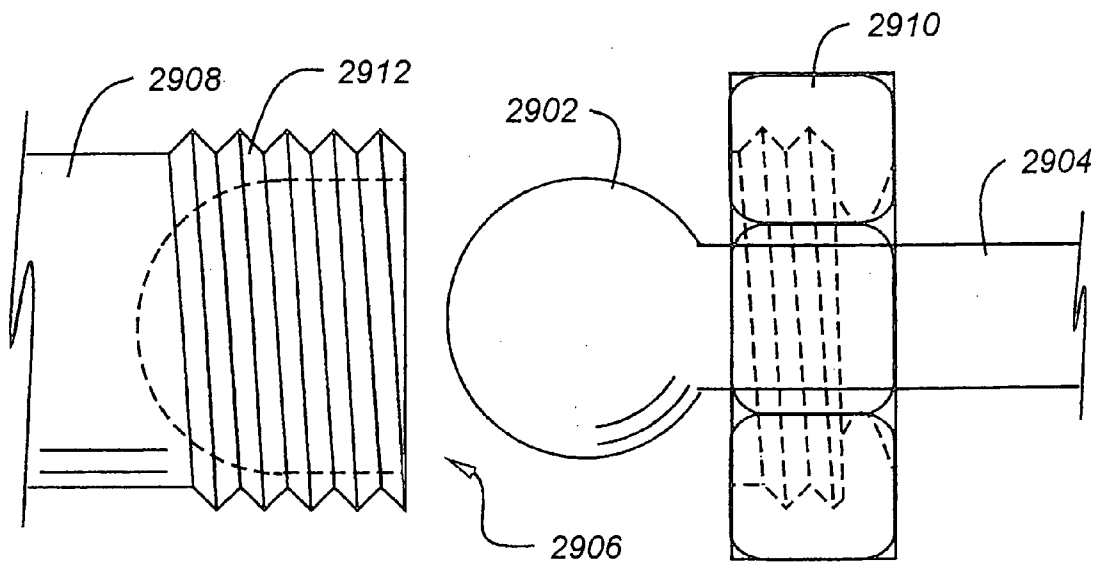

Fig - 28



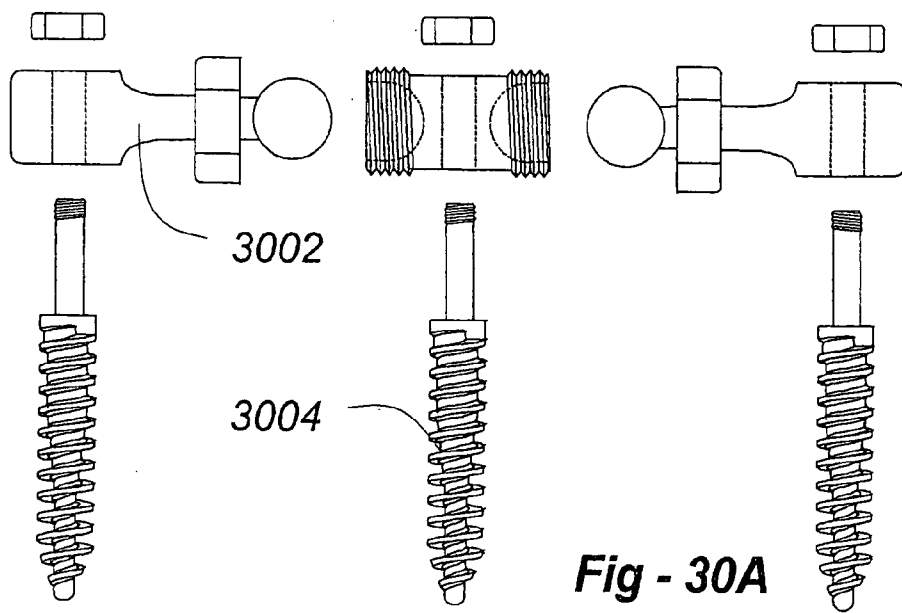

Fig - 30A

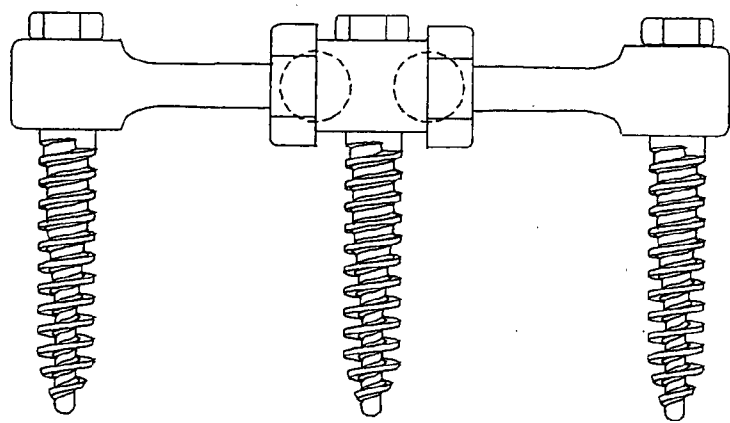

Fig - 30B

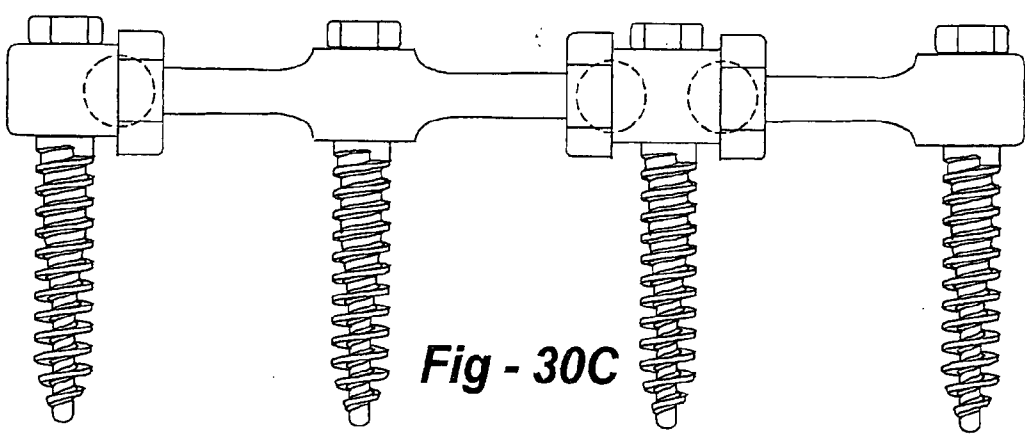

Fig - 30C

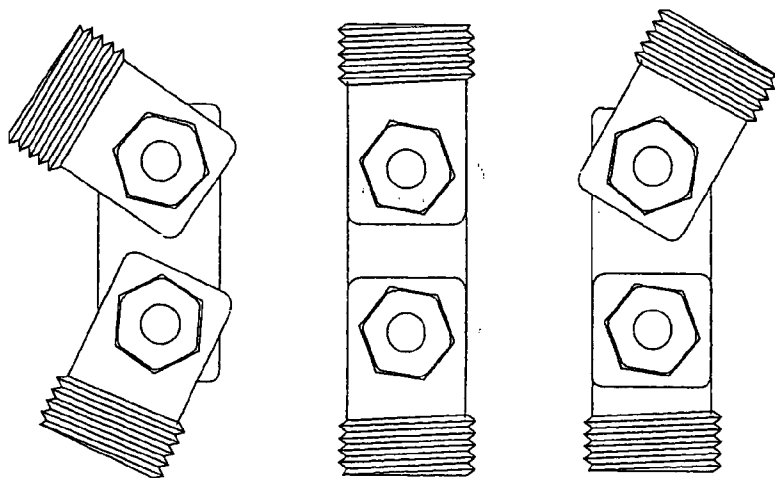

Fig - 31C

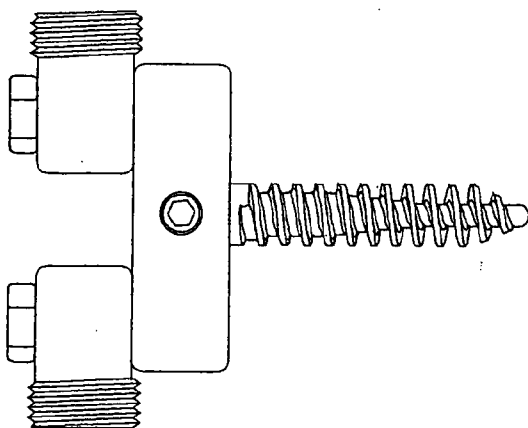

Fig - 31B

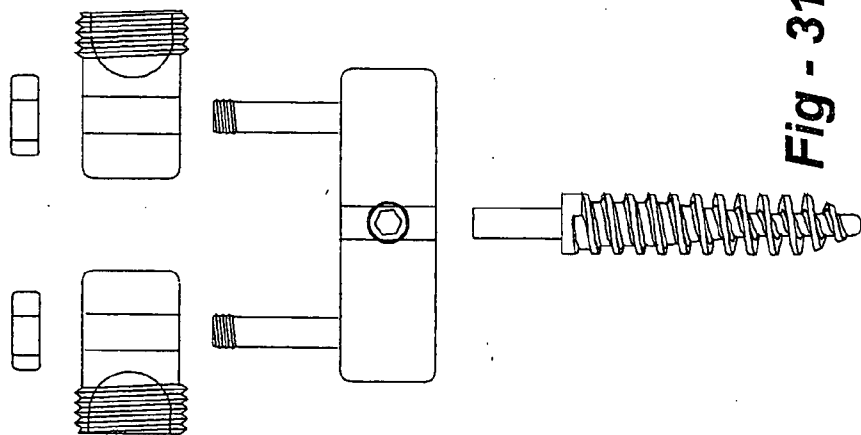

Fig - 31A

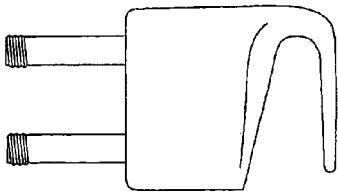

Fig - 32

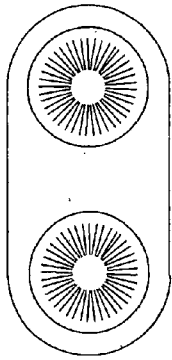

Fig - 33A

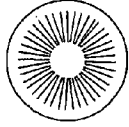

Fig - 33B

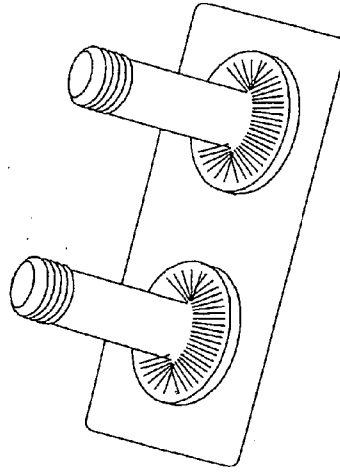
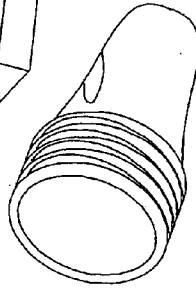
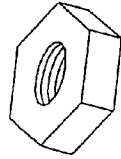

Fig - 33D

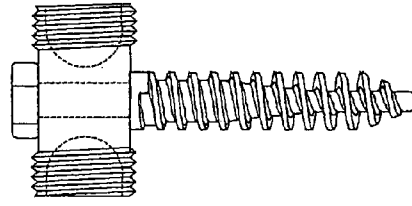

Fig - 33E

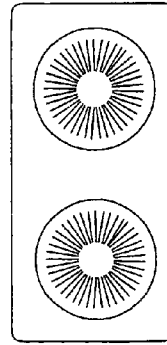
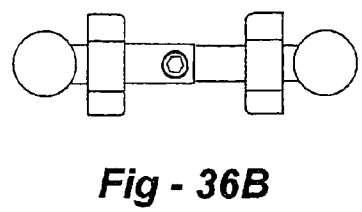
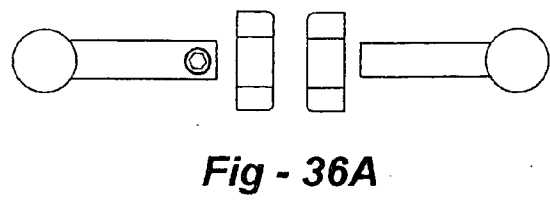
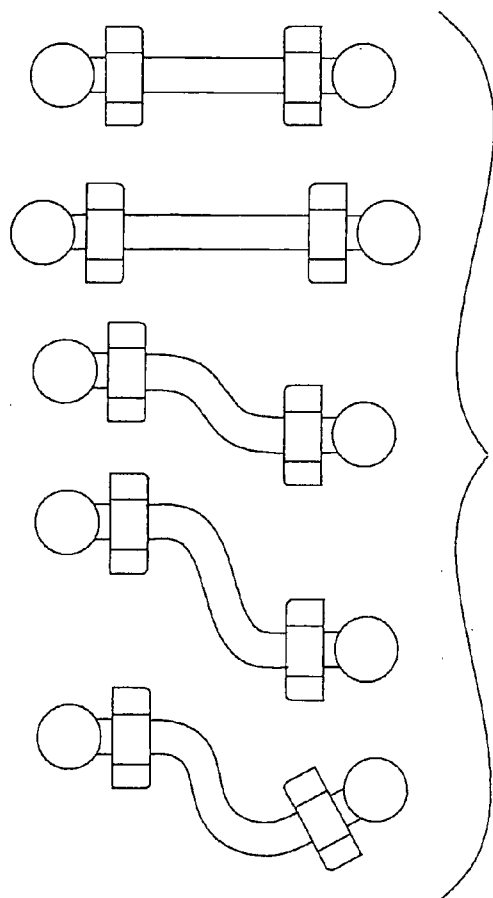
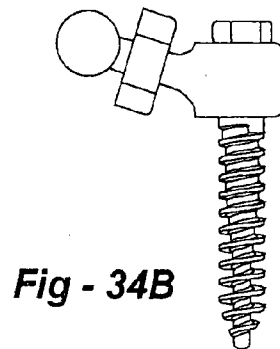
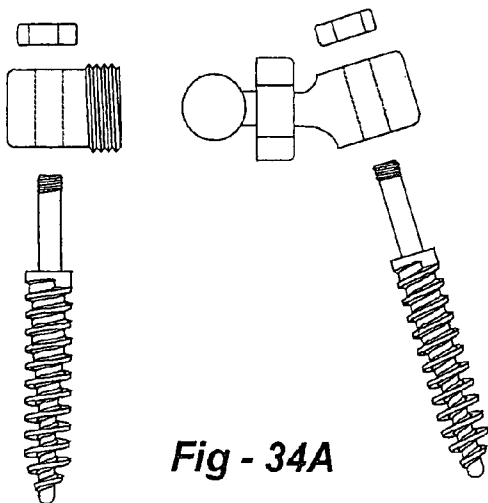

Fig - 33C



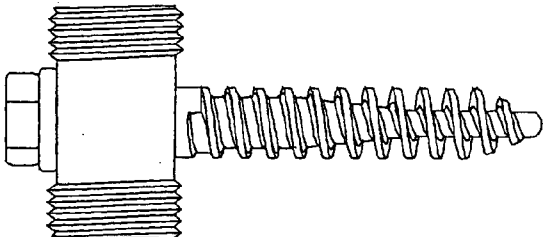

Fig - 39

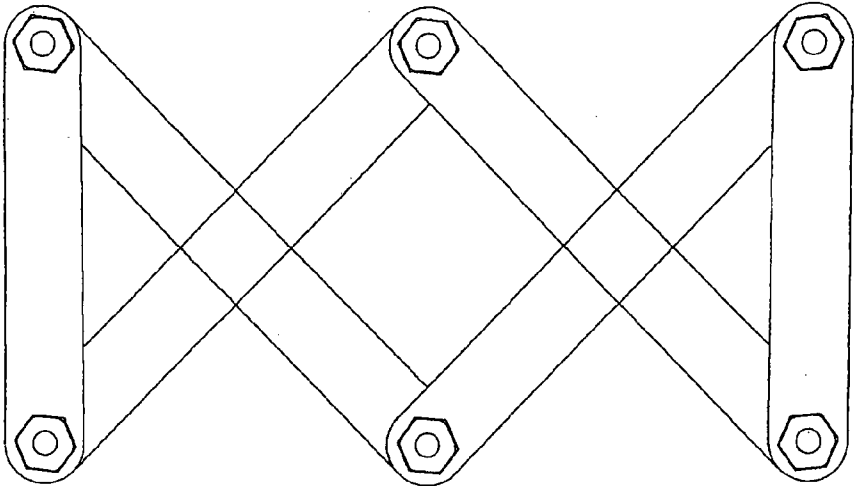

Fig - 38

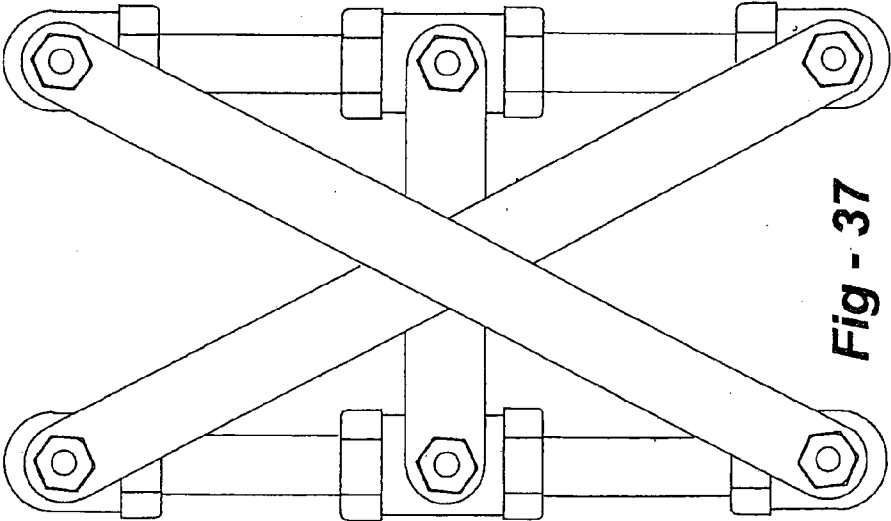

Fig - 37

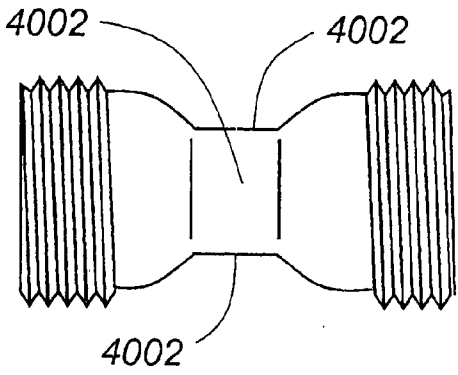

Fig - 40A

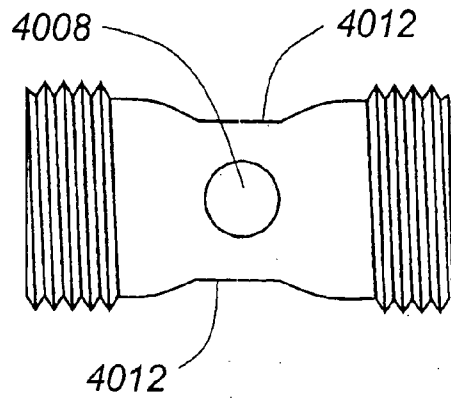

Fig - 40B

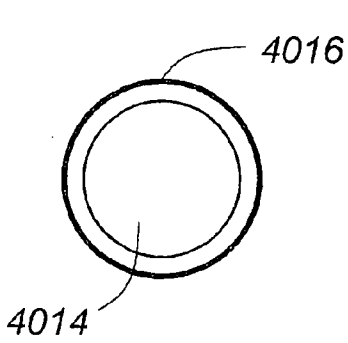

Fig - 40C

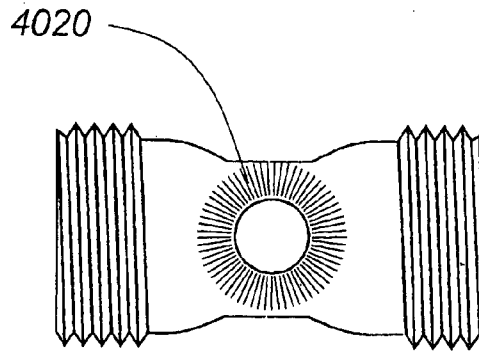

Fig - 40D

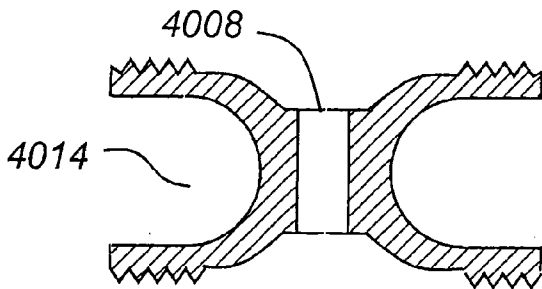

Fig - 40E

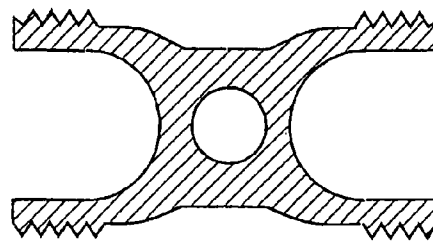

Fig - 40F

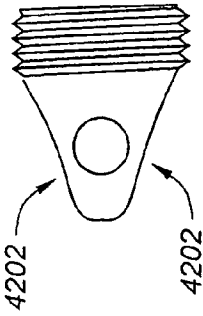

Fig - 42B

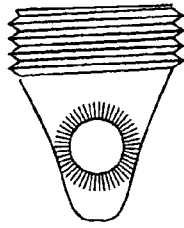

Fig - 42D

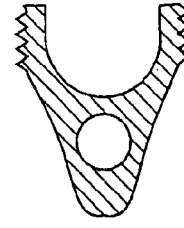

Fig - 42E

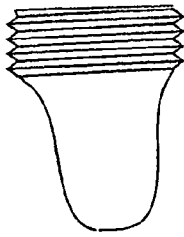

Fig - 42A

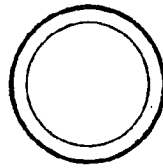

Fig - 42C

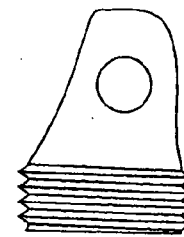

Fig - 41G

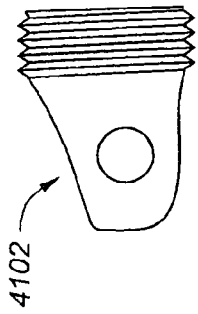

Fig - 41B

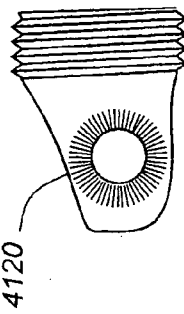

Fig - 41D

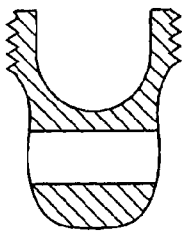

Fig - 41F

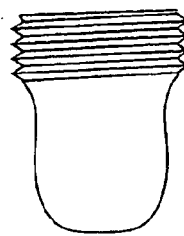

Fig - 41A

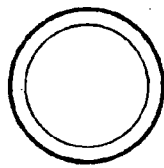

Fig - 41C

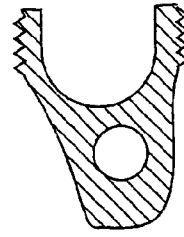

Fig - 41E

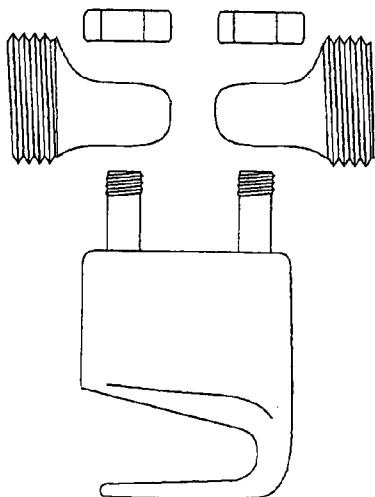

Fig - 43A

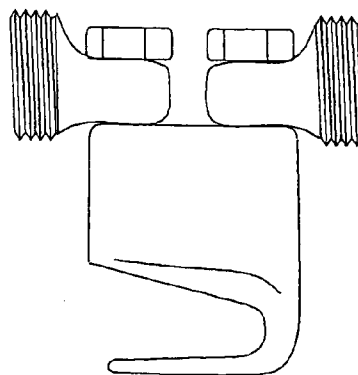

Fig - 43B

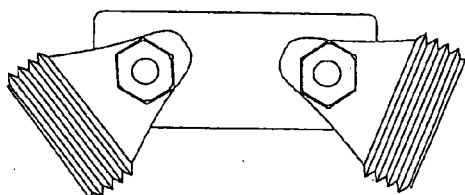

Fig - 44A

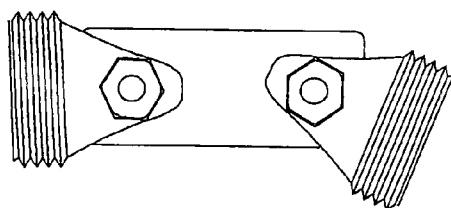

Fig - 44B

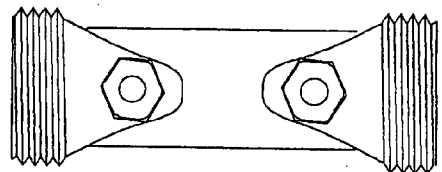

Fig - 44C

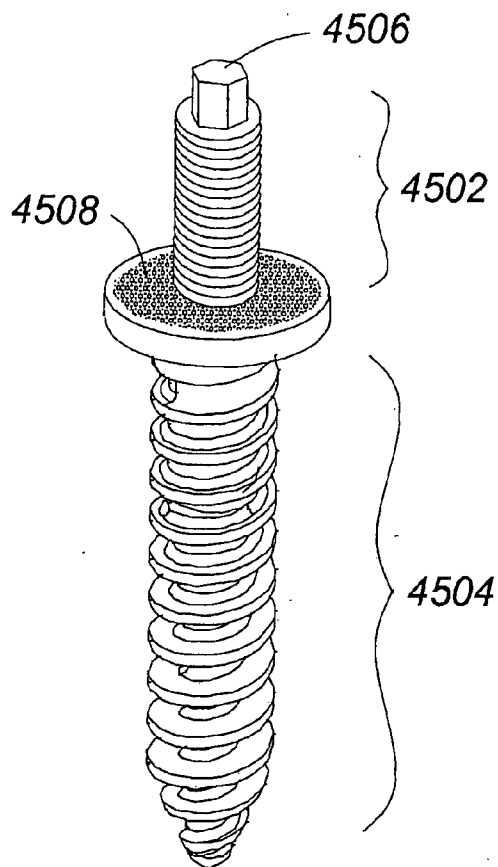

Fig - 45

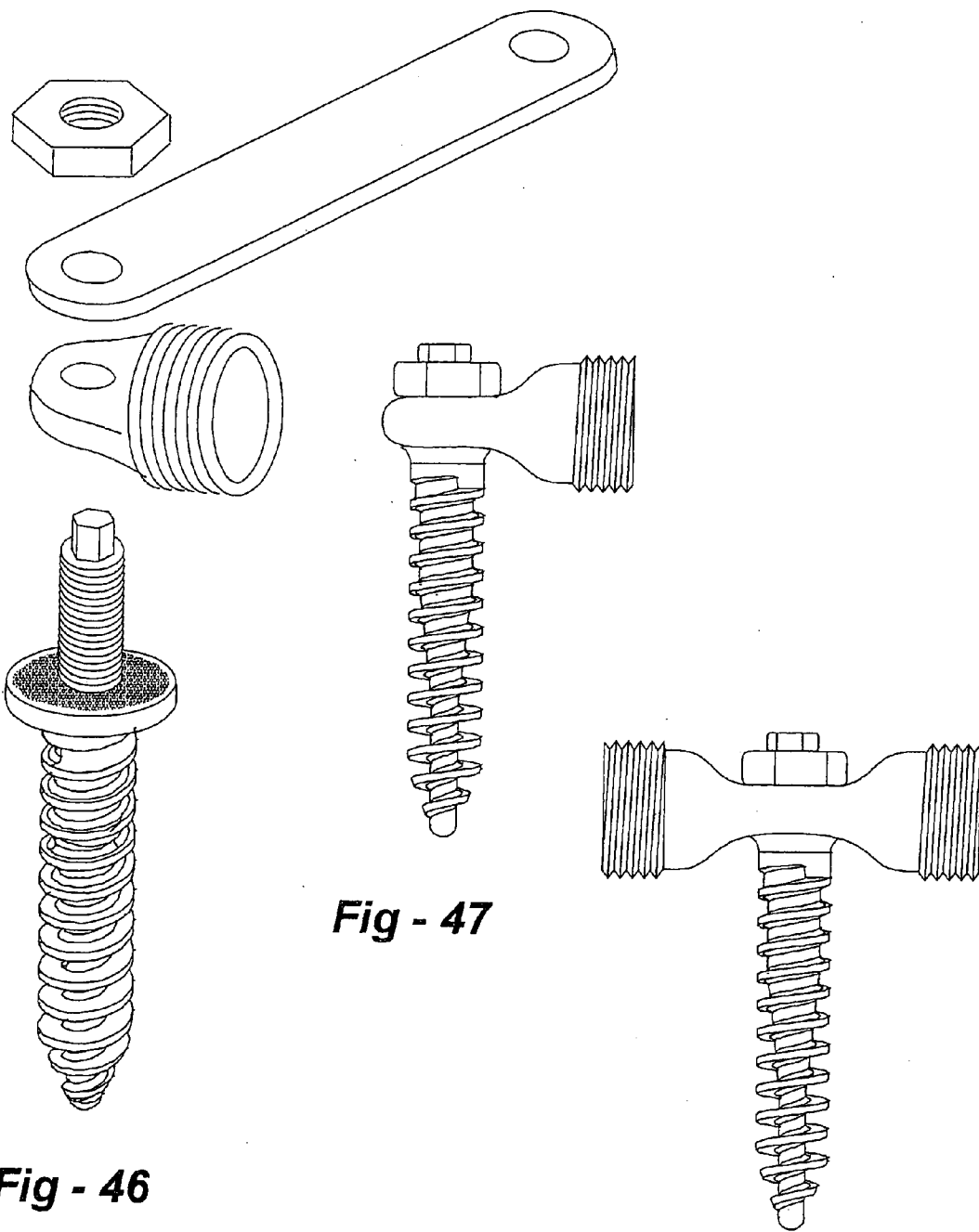

Fig - 46

Fig - 47

Fig - 48

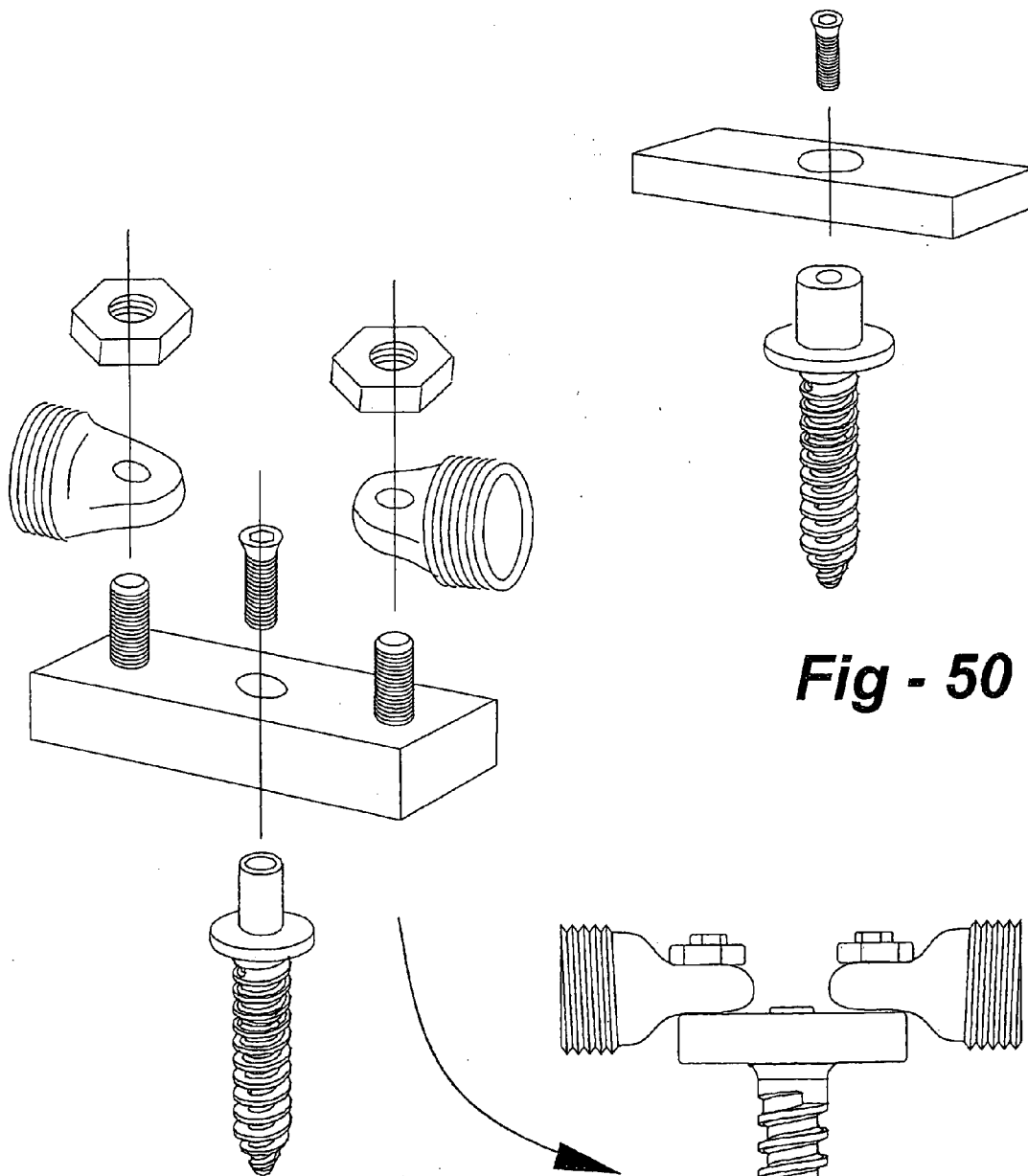

Fig - 49

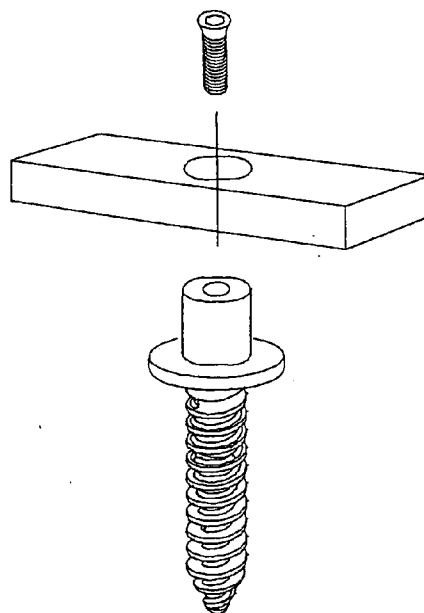
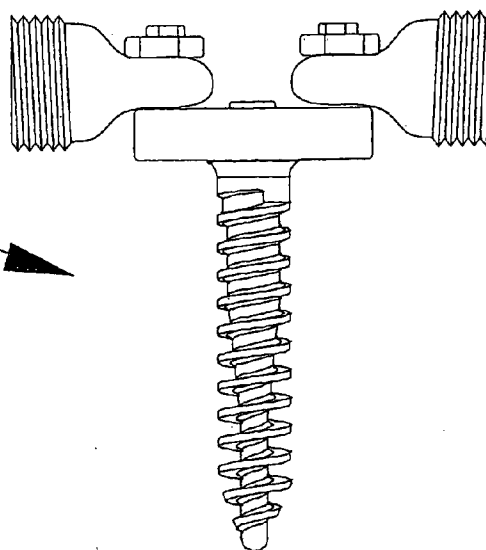

Fig - 50



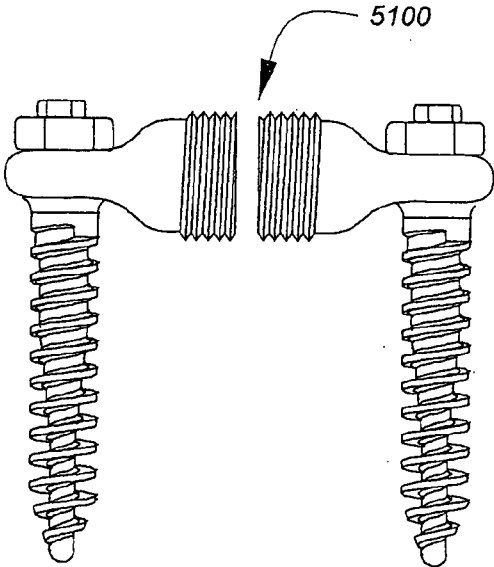

Fig - 51

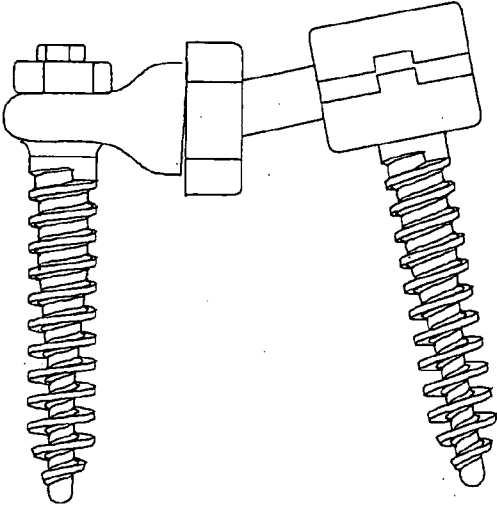
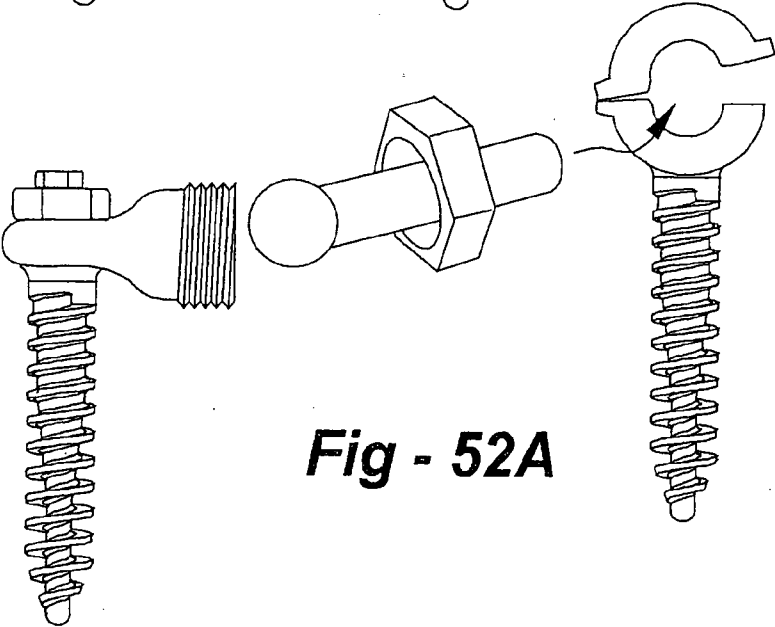

Fig - 52B

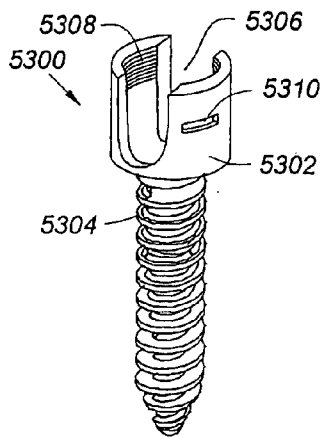

Fig - 53A

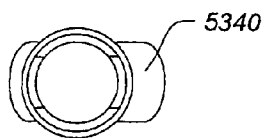

Fig - 53E

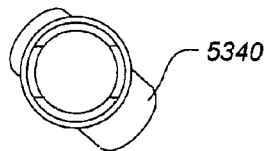

Fig - 53F

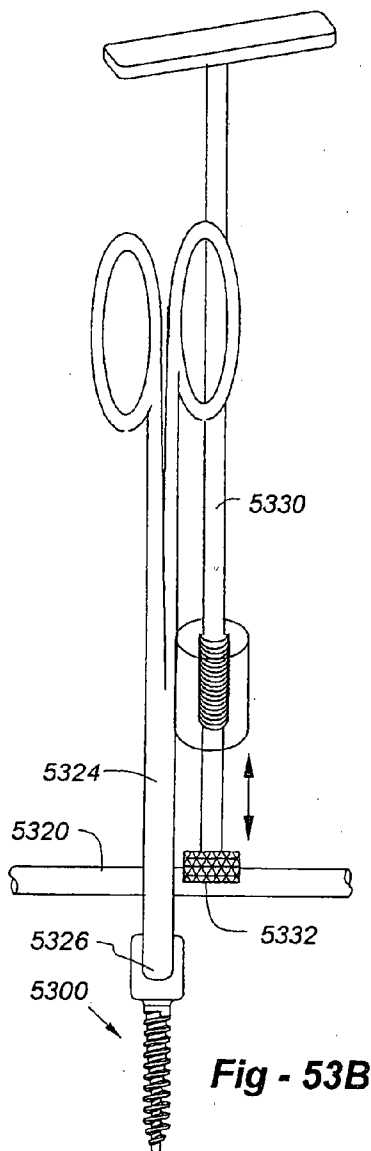

Fig - 53B

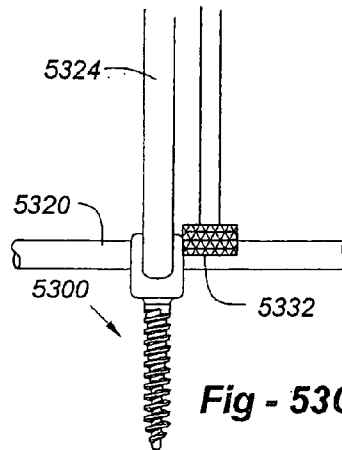

Fig - 53C

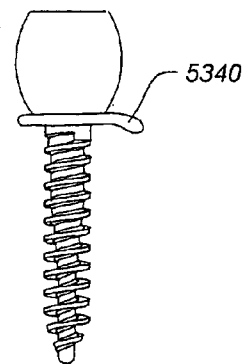

Fig - 53D

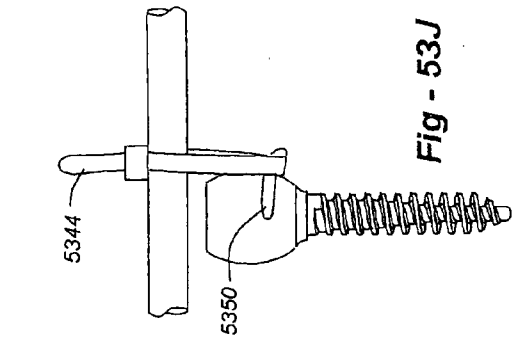

Fig - 53J

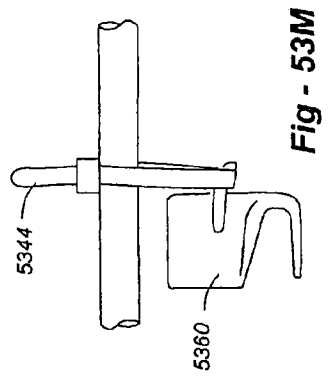

Fig - 53M

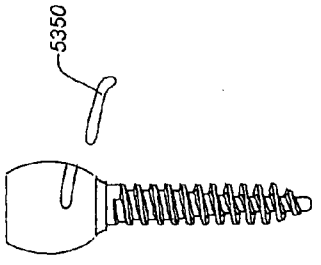

Fig - 53I

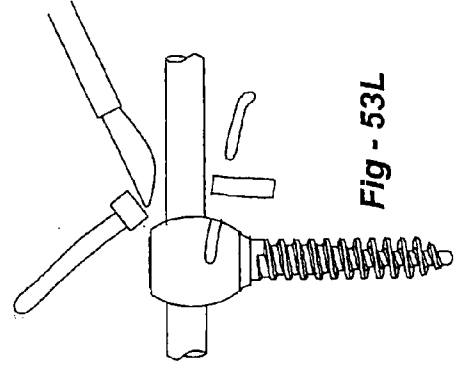

Fig - 53L

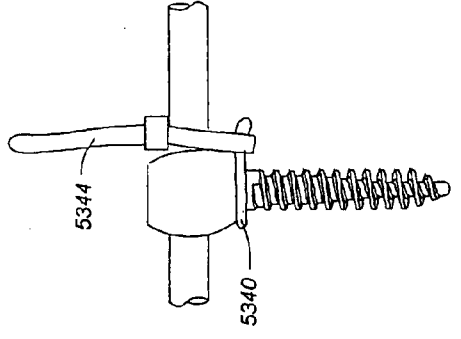

Fig - 53H

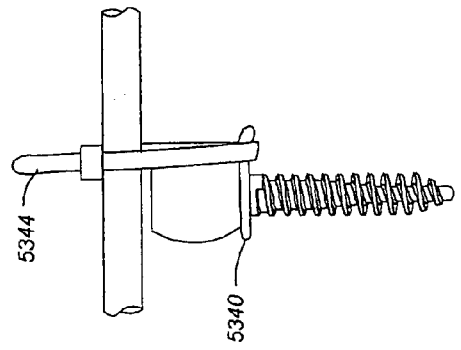

Fig - 53G

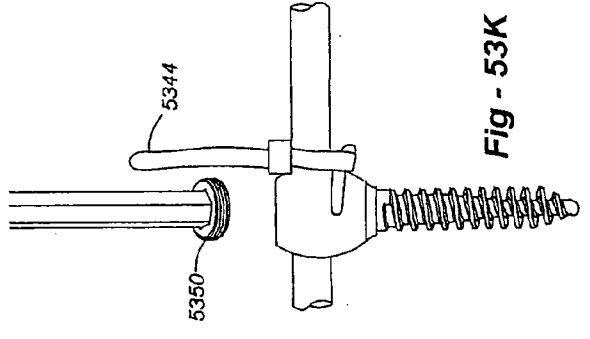

Fig - 53K

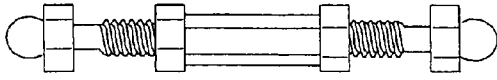

Fig - 54

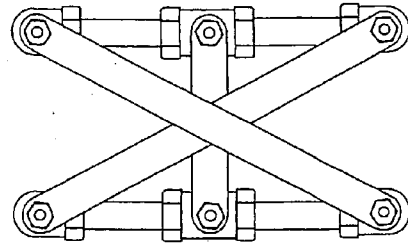

Fig - 55

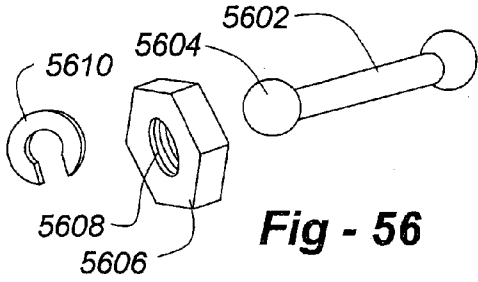

Fig - 56

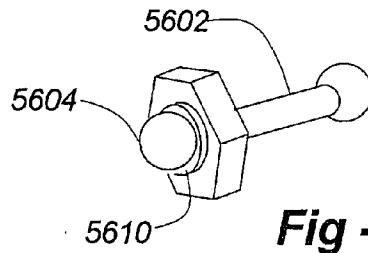

Fig - 57

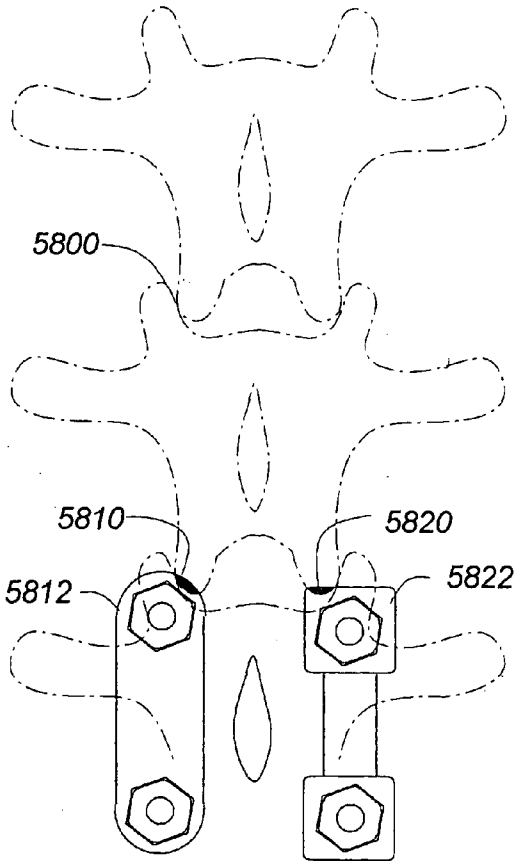

Fig - 58A

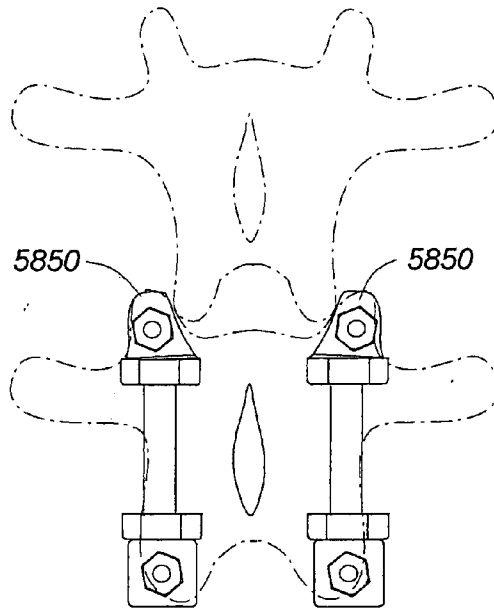

Fig - 58B

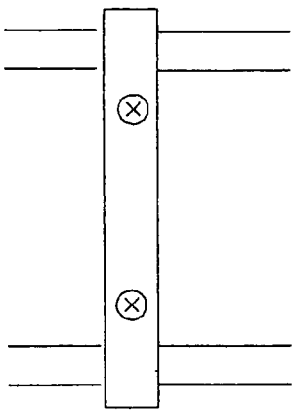

Fig - 59A

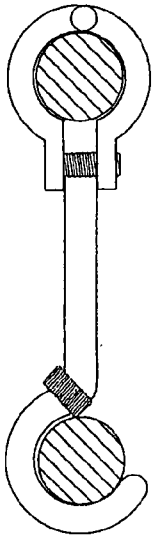

Fig - 59B

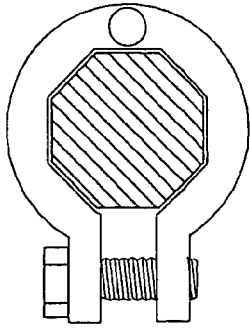
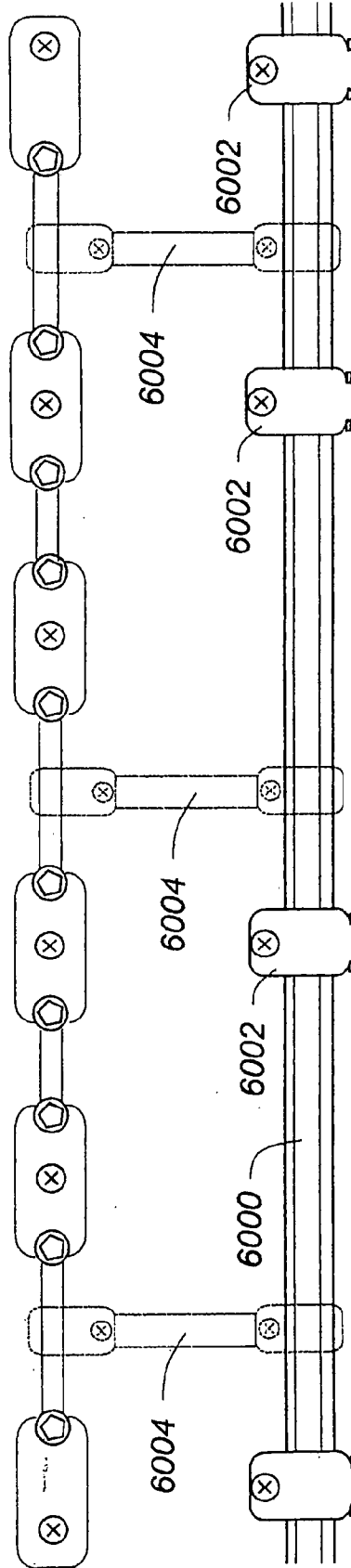

Fig - 61

Fig - 60



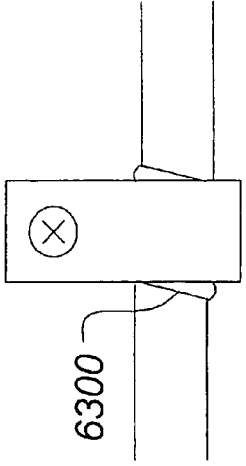

Fig - 63

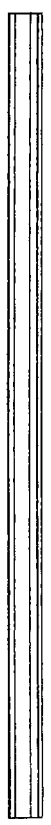

Fig - 62A



Fig - 62B

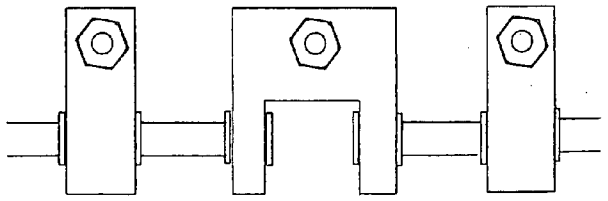

Fig - 64

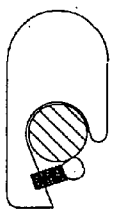

Fig - 65B

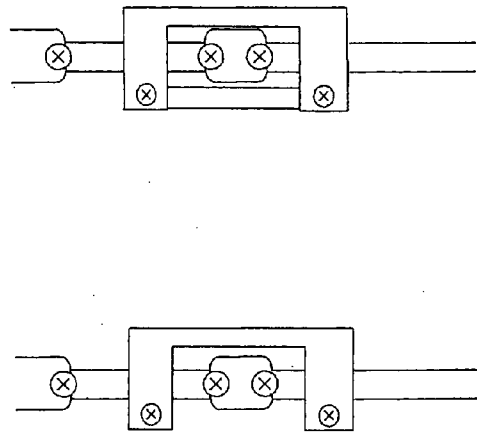

Fig - 66A

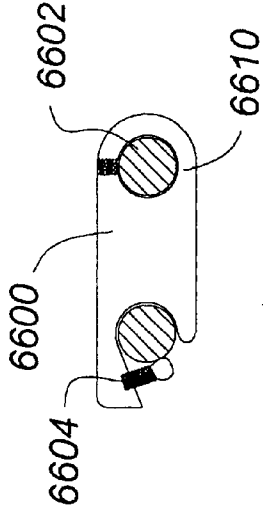

Fig - 66B

Fig - 65A

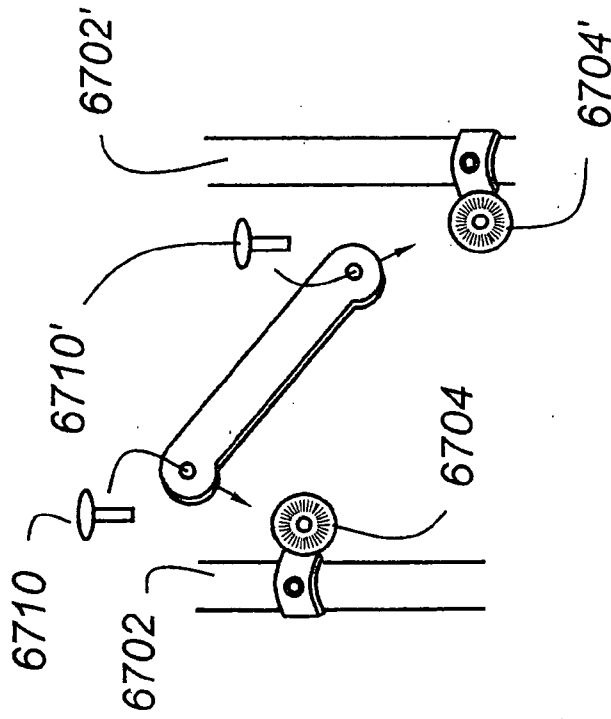

Fig - 67A

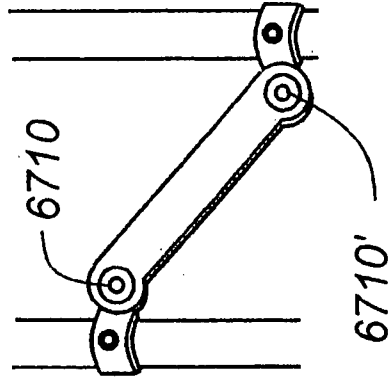

Fig - 67B

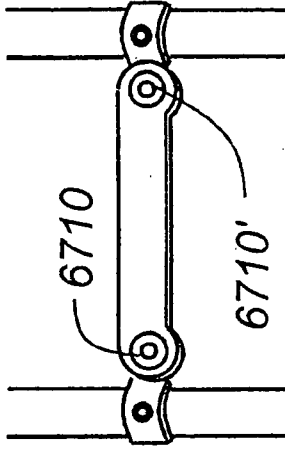

Fig - 67C

SPINAL ALIGNMENT SYSTEM AND RELATED METHODS

CROSS REFERENCES TO RELATED APPLICATIONS

[0001] The present application claims priority under 35 U.S.C. § 120 from the commonly owned and co-pending U.S. patent application Ser. No. 10/894,533, filed on Jul. 19, 2004, which itself claims priority under 35 U.S.C. § 120 from U.S. patent application Ser. No. 10/105,971, filed on Mar. 25, 2002, now issued as U.S. Pat. No. 6,802,844, the complete disclosures of which are hereby incorporated herein by reference in their entireties for all purposes. Additionally, the present application claims benefit under 35 U.S.C. §119(e) from U.S. Provisional Application Ser. No. 60/278,910, filed on Mar. 26, 2001, the entire contents of which are hereby expressly incorporated by reference into this disclosure as if set forth fully herein.

BACKGROUND OF THE INVENTION

[0002] I. Field of the Invention

[0003] This invention relates generally to instrumentation, tools and techniques associated with spinal fixation and, in particular, to apparatus and methods facilitating spinal correction in multiple dimensions.

[0004] II. Description of the Related Art

[0005] The human spine exhibits some degree of curvature at different levels to facilitate normal physiologic function. Correction may be required when this curvature deviates substantially. A common problem is lateral deviation of the spine, commonly termed scoliosis.

[0006] Spinal deformity occurs when a patient has abnormal frontal or sagittal plane alignment. At the same time, the cervical and lumbar spine exhibit lordosis, while the thoracic spine has kyphosis. Thus, when performing spinal fusion, surgeons may be required to preserve or restore both front plane and sagittal alignment while taking lordosis and kyphosis into account.

[0007] As discussed in U.S. Pat. No. 5,540,689, the first successful internal fixation method for surgically treating scoliosis used the Harrington instrumentation system. According to this technique, a rigid rod with hooks at each end is implanted adjacent the concave side of the scoliotic spine. The spine is manually straightened to a desired extent and a distraction rod is used to maintain the correction by exerting vertical forces at each end. The rod commonly has a ratcheted end over which hooks are slidably mounted and locked in place. To accommodate lordosis, a compression rod is sometimes placed on the convex side of the scoliotic spine.

[0008] The Harrington instrumentation system has been used successfully for some time, but because the distraction rod is fixed to the spine in only two places, failure at either end causes the entire system to fail. Another deficiency with existing mechanisms and approaches is that the single rod used to correct the defects must be contoured to fit various attachment sites. In patients having compound spinal deformity, this may be extremely difficult. A further problem is that the contoured rod frequently limits further correction of certain types of deformities. That is, once the rod is in

position, further correction of the deformity is difficult, since existing systems tend to limit incremental alignment procedures.

[0009] An alternative treatment has since evolved which takes advantage of segmented fixation. According to this method, a rod is fixed to the spine at multiple points by means of sublaminar wires which run underneath the lamina of the vertebra and around the rod. The use of multiple fixation sites enhances stability and reduces the need for additional post-operative bracing.

[0010] Sublaminar fixation utilizing current devices has two primary weaknesses, however. First, the wires are simply wrapped around the rod, resulting in a rod to cable junction which is not rigid. Second, the thin wires can cut in some instances right through the lamina.

[0011] U.S. Pat. No. 6,019,759 uses multiple longitudinal members with flat plates that attach using hooks or screws. However, the plates are stacked on top of one another at each attachment site, resulting in an overall structure that tends to be quite thick. Systems having a high sagittal profile are often thick enough to be felt through the skin. Additionally, the teachings of the '759 patent do not allow for easy correction or preservation of sagittal alignment.

[0012] The need remains, therefore, for a system and method that allows incremental correction of spinal defects, ideally in all three dimensions.

SUMMARY OF THE INVENTION

[0013] This invention resides in spinal alignment apparatus, including implantable components, instrumentation, and methods of use. In broad and general terms, the preferred embodiment includes bodies which connect to the vertebra to be aligned, and elongated elements that connect to the bodies. The elements are preferably adjustable relative to the bodies in multiple dimensions, with locking mechanisms that allow the alignment to proceed in an orderly fashion until a desired degree of correction is achieved.

[0014] Each rigid, elongated element has at least one end terminating in the first portion of the lockable coupling mechanism. The vertebral connector bodies each include a feature for attaching the body to a respective vertebrae, and the second portion of the lockable coupling mechanism. This arrangement permits the elongated elements to be adjusted in multiple dimensions relative to a given connector body prior to being lockingly coupled thereto.

[0015] The feature for attaching the body to its respective vertebrae may include a pedicle screw or, alternatively, a shape such as a hook adapted for sublaminar engagement. The elongated elements may also preferably include a length adjustment mechanism, such as a telescoping or threaded section, to provide a desired length in conjunction with a desired degree of alignment.

[0016] Various coupling mechanisms are disclosed to provide multiple degrees of freedom prior to fixation. In the preferred embodiment, the mechanism includes a fixed or adjustable-length rod having ball-shaped ends coupled to a vertebral connector providing multiple degrees of freedom before being locked into position once a desired orientation is achieved.

BRIEF DESCRIPTION OF THE DRAWINGS

[0017] Many advantages of the present invention will be apparent to those skilled in the art with a reading of this specification in conjunction with the attached drawings, wherein like reference numerals are applied to like elements and wherein:

[0018] FIG. 1A is a frontal view of elongated rods and hooks currently used to correct spinal defects;

[0019] FIG. 1B shows the use of two rods in place, attached to multiple vertebrae;

[0020] FIG. 1C illustrates the way in which a typical prior-art hook is positioned under the spinal lamina for rod insertion;

[0021] FIG. 2A is a frontal view of basic instrumentation according to the present invention utilizing elongated members in the form of links of different length as opposed to longer rods;

[0022] FIG. 2B shows the instrumentation of FIG. 2A in place relative to multiple vertebrae;

[0023] FIG. 3A illustrates components associated with a preferred embodiment of the present invention, including a one- and multiple-opening pedicle screws, compound rods, tightening bands, and fasteners;

[0024] FIG. 3B is a detail drawing of a single-opening pedicle screw according to the present invention;

[0025] FIG. 3C is a top-down view of the single-opening pedicle screw of FIG. 3B;

[0026] FIG. 3D is a detail drawing of a multi-opening pedicle screw according to the present invention;

[0027] FIG. 3E is a top-down view of the multi-opening pedicle screw of FIG. 3D;

[0028] FIG. 3F shows a preferred setscrew fastener according to the present invention for use with the single- and multi-opening fasteners of FIGS. 3A through 3E;

[0029] FIG. 3G shows the way in which caps may be added to elongated members according to the present invention to produce spherical or semi-spherical endings;

[0030] FIG. 3H shows the way in which multiple elongated members may be interconnected to produce a single spherical or semi-spherical joint region;

[0031] FIG. 3I illustrates components associated with an alternative embodiment of the invention, including a pedicle screw, swivel connector and locking links;

[0032] FIG. 3J illustrates an embodiment of the invention similar to that depicted in FIG. 3I, but wherein the pedicle screw includes a threaded end as opposed to a ball-end-socket type of connection;

[0033] FIG. 3K is a side view of a preferred transverse connector according to the invention;

[0034] FIG. 3L is a top view of the transverse connector of FIG. 3K;

[0035] FIG. 3M is a top view of the transverse connector of FIG. 3K, illustrating multiple degrees of freedom made possible by the arrangement;

[0036] FIG. 3N depicts multiple views of the preferred transverse connector of FIG. 3K, showing various degrees of angulation;

[0037] FIG. 3O illustrates the use of a ball joint that permits the preferred transverse connector to accommodate non-parallel rods;

[0038] FIG. 3P is an end view of the preferred transverse connector used to illustrate the desirability of reduced dimensions;

[0039] FIG. 4A illustrates a sublaminar hook according to the invention having a ball-shaped connector;

[0040] FIG. 4B illustrates a sublaminar hook according to the invention having a threaded connector;

[0041] FIG. 4C illustrates a sublaminar hook embodiment of the invention featuring two opposing spherical joints;

[0042] FIG. 4D illustrates a sublaminar hook embodiment of the invention featuring a single spherical joint;

[0043] FIG. 5A illustrates one use of cross-links according to the invention;

[0044] FIG. 5B illustrates an alternative cross-link configuration according to the invention;

[0045] FIG. 6A shows the use of clamps as part of a first step to realign vertebrae for use with at least one embodiment of the invention;

[0046] FIG. 6B shows the vertebrae in alignment using the clamps of FIG. 6A;

[0047] FIG. 6C shows the installation of linking rods to align the vertebrae, enabling the clamps to be removed;

[0048] FIG. 7A shows a first step associated with restoring frontal alignment according to the present invention;

[0049] FIG. 7B illustrates an initial application of rods to restore frontal alignment;

[0050] FIG. 7C illustrates an intermediate rod installation;

[0051] FIG. 7D illustrates a completed rod-and-connector structure to restore frontal alignment;

[0052] FIG. 8A illustrates a first step associated with restoring sagittal alignment;

[0053] FIG. 8B shows two vertebrae with appropriate sagittal alignment in preparation for rod insertion;

[0054] FIG. 8C shows the vertebrae of FIGS. 8A and 8B, with a linking rod in place and a tool and the tool removed;

[0055] FIG. 9 illustrates the use of a tool used to remove a connector from a ball-tip type of pedicle screw according to the present invention;

[0056] FIG. 10 depicts an alternative embodiment of the present invention, wherein connectors include multiple apertures for linking bars;

[0057] FIG. 11A shows the configuration of FIG. 10 with lines indicating a desired placement of cross-members;

[0058] FIG. 11B shows the linking members of FIGS. 10 and 11A with optional sublaminar cabling;

[0059] FIG. 12A is a drawing of an alternative connector having multiple apertures for linking bars or other elements;

[0060] FIG. 12B shows the alternative connector of FIG. 12A with lines indicating one possibility for cross-linking;

[0061] FIG. 13 shows the use of diagonal connectors according to the invention for use with existing rod- or plate-alignment systems;

[0062] FIG. 14 shows diagonal connectors for use with existing rod or plate systems, but with attachment made relative to the pedicle screws as opposed to the linking members;

[0063] FIG. 15A illustrates an alternative embodiment wherein struts are stacked over one another onto pedicle screws;

[0064] FIG. 15B illustrates the use of cross-link member in conjunction with the embodiment of FIG. 15A;

[0065] FIG. 16 is a side-view drawing of yet a further alternative connector according to the invention wherein more space is provided to tighten and loosen associated pedicle screws;

[0066] FIG. 17 shows a telescoping rod that may be adapted for use with any of the embodiments described herein;

[0067] FIG. 18A illustrates a sublaminar hook having swivel connectors to which the ends of the telescoping rod of FIG. 17 may attach;

[0068] FIG. 18B is a top-down view of the hook of FIG. 18A;

[0069] FIG. 18C is a cross-sectional view of the hook of FIG. 18A;

[0070] FIG. 19 illustrates a pedicle-screw version of the hook of FIG. 18A, also including locking connectors that swivel;

[0071] FIG. 20 is a side-view of the spine illustrating the utilization of hook and pedicle-screw connectors according to one embodiment of the present invention;

[0072] FIG. 21 is a top-view drawing of the spine, showing the use of cross connectors employed in an angular fashion to maximize rigidity;

[0073] FIG. 22A shows the way in which a telescoping connector according to the invention is installed;

[0074] FIG. 22B illustrates an intermediate adjustment procedure associated with the use of a telescoping rod according to the invention;

[0075] FIG. 22C shows the telescoping rod locked into place once a desired level of alignment is achieved;

[0076] FIG. 23 is a drawing of a threaded cross-connector according to the invention;

[0077] FIG. 24 is a drawing of a telescoping rod according to the invention having an arch feature that allows placement over arched lamina;

[0078] FIG. 25 is a cross-sectional drawing of a transverse connector according to the invention associated with a rod junction;

[0079] FIG. 26A illustrates the use of a further alternative embodiment of the invention featuring a telescoping rod that engages with hooks having one or more posts;

[0080] FIG. 26B shows the rod of FIG. 26A being rotated to achieve a desired level of alignment;

[0081] FIG. 26C is a close-up view of the rotation procedure;

[0082] FIG. 27 shows an alternative connector according to the present invention providing the ability to vary angulation in two planes;

[0083] FIG. 28 is an alternative connector according to the present invention which also affords multiples degrees of freedom;

[0084] FIG. 29A depicts an alternative connector according to the present invention that uses a ball and socket held in position with a threaded fastener;

[0085] FIG. 29B shows the alternative connector of FIG. 29A locked into a desired orientation;

[0086] FIG. 30A shows an embodiment of the invention wherein a connector body and elongated element are integrally formed to achieve a low-profile interconnection scheme;

[0087] FIG. 30B shows the configuration of FIG. 30A in an assembled condition;

[0088] FIG. 30C shows the way in which connector bodies having multiple male and female connectors may be joined together in succession;

[0089] FIG. 31A shows a swiveling, socket-type connector according to the invention on a body attached to a pedicle screw;

[0090] FIG. 31B shows the arrangement of FIG. 31A in an assembled condition;

[0091] FIG. 31C is a series of top-down drawings illustrating the swiveling feature of the embodiments of FIGS. 31A and 31B;

[0092] FIG. 32 shows a sublaminar hook having outward projections to receive swivel connectors;

[0093] FIG. 33A is a drawing of a top-down view of a screw connector having two posts;

[0094] FIG. 33B is a top view of a screw connector according to the invention having a single post;

[0095] FIG. 33C is a top view of a single hook connector;

[0096] FIG. 33D is an oblique drawing that shows the use of frictional surfaces to lock in the swivel action upon achieving a desired orientation;

[0097] FIG. 33E shows how one or more manually adjustable fasteners may be added to help control rotation of a connector according to the invention;

[0098] FIG. 34A shows how a combined longitudinal member and connector may have different lengths and angles to address different alignment situations;

[0099] FIG. 34B illustrates an assembled version of an angled unit;

[0100] FIG. 35 is a series of drawings that show a variety of longitudinal members in straight and curved configurations;

[0101] FIG. 36A shows how a telescoping member may be assembled through a pair of nuts, then joined;

[0102] FIG. 36B shows a joined assembled version of the assembly of FIG. 36A;

[0103] FIG. 37 illustrates the combined use of ball-and-socket connectors and rigid link plates;

[0104] FIG. 38 illustrates the overlapping of rigid link plates at different vertebral levels;

[0105] FIG. 39 is a side view of a connector according to the invention including a cross-link;

[0106] FIGS. 40A-40F provide different views of a central lumbar connector according to the present invention;

[0107] FIGS. 41A-41G depict different views of a lumbar connector adapted to the cephalad end;

[0108] FIGS. 42A-42E show different views of thoracic connectors according to the invention;

[0109] FIGS. 43A and 43B show exploded and assembled views, respectively, of sublaminar hooks with thoracic connectors attached thereto;

[0110] FIGS. 44A-44C are top views showing swiveling before and after locking into a straightened configuration;

[0111] FIG. 45 is a drawing of a pedicle screw used to discuss different sizes and diameters;

[0112] FIG. 46 is a perspective view of the pedicle screw of FIG. 45 including a ball connector and link bar;

[0113] FIG. 47 shows the configuration of FIG. 46 in an assembled state;

[0114] FIG. 48 is an assembled connector having two opposing ball-receiving sockets;

[0115] FIG. 49 is an exploded and assembled view of a pedicle screw having independent double connectors;

[0116] FIG. 50 shows how a non-round (in this case, oval) interconnection may be used to prevent rotation of the pedicle screw relative to a connector body;

[0117] FIG. 51 introduces the use of a hinged connector according to the present invention;

[0118] FIG. 52A shows the hinge connector in an open condition;

[0119] FIG. 52B shows a hinge connector locked onto a rod;

[0120] FIGS. 53A-53M illustrate the alternative use of straps according to the invention for rod movement and stabilization;

[0121] FIG. 54 is a side view of a turnbuckle rod according to the invention;

[0122] FIG. 55 shows the combined use of ball-and-socket connectors in crisscross link bars;

[0123] FIG. 56 shows how a half-washer may be used in conjunction with a nut opening that is large enough to slide over the sphere at the end of a rod;

[0124] FIG. 57 shows an alternative use of a slotted washer permitting a nut to slide over the spherical end of a solid rod;

[0125] FIG. 58A shows a modified connector adapted may be used to reduce impingement;

[0126] FIG. 58B illustrates an anti-impingement connector utilizing a ball-and-socket arrangement;

[0127] FIGS. 59A and 59B are different views of a transverse connector according to the present invention;

[0128] FIG. 60 shows the combined use of transverse connectors and hinged hooks that lock onto a solid rod;

[0129] FIG. 61 is a close-up, end view of a hinged connector associated with an octagonal rod;

[0130] FIG. 62A illustrates the use of a continuous shaped rod, in this case having a grooved cross-section;

[0131] FIG. 62B illustrates how the modification along the rod may be interrupted according to the present invention;

[0132] FIG. 63 shows a bevel connector;

[0133] FIG. 64 illustrates the use of multiple rods on either side of the spine;

[0134] FIG. 65A shows a stabilization clamp for use with various embodiments disclosed herein;

[0135] FIG. 65B is an end of the configuration of FIG. 65A;

[0136] FIG. 66A is a different alternative embodiment of a stabilizing assembly;

[0137] FIG. 66B is a cross-section of the assembly of FIG. 66A; and

[0138] FIGS. 67A-67C illustrate the use of lockable swivel-type connectors which may be fastened to one or, preferably a pair, of alignment rods to provide a desired degree of alignment and correction.

DETAILED DESCRIPTION OF THE PREFERRED EMBODIMENTS

[0139] Illustrative embodiments of the invention are described below. In the interest of clarity, not all features of an actual implementation are described in this specification. It will of course be appreciated that in the development of any such actual embodiment, numerous implementation-specific decisions must be made to achieve the developers' specific goals, such as compliance with system-related and business-related constraints, which will vary from one implementation to another. Moreover, it will be appreciated that such a development effort might be complex and time-consuming, but would nevertheless be a routine undertaking for those of ordinary skill in the art having the benefit of this disclosure. The spinal alignment apparatus and related methods disclosed herein boast a variety of inventive features and components that warrant patent protection, both individually and in combination.

[0140] FIGS. 1A through 1C present simplified representations regarding the way in which prior-art hooks and rods are used to treat spinal deformities. FIG. 1A shows a plurality of vertebrae 102 in need of alignment. In accordance with existing practice, hooks 104 are fastened to the vertebrae at points deemed to be useful by the attending surgeon. Tools are used in an attempt to align the vertebrae, at which time rods 106 are contoured at the time of the procedure to engage with the hooks 104 to maintain a desired degree of straightening, as shown in FIG. 1B. FIG. 1C illustrates the way in which a typical prior-art hook is positioned under the spinal lamina for rod insertion.

[0141] FIG. 2A illustrates basic instrumentation according to one embodiment of the invention. As opposed to the hooks 104 of prior-art devices, rotating/swiveling connectors 204 are instead used. In addition, as opposed to the rods 106 which currently must be contoured, links 206 of varying fixed or adjustable length are coupled to the connectors, and the entire structure locked into a preferred orientation, as

shown in FIG. 2B. Although rotating/swiveling connectors having two rod-receiving positions are shown, the preferred embodiment of FIG. 3 shows how compound elements may be used for a single compression fitting and very low profile.

[0142] FIG. 3A illustrates a preferred system according to the invention, depicted generally at 10. Broadly, the system includes single-opening bodies 20, multiple-opening bodies 40, and rods 80. To afford additional degrees of freedom in multiple dimensions, the invention contemplates the use of rods having ball-shaped ends as well as the flattened plates of FIGS. 3I and 3J. Although the ball-shaped ends are shown as joinable to permit a single compression fastener as described below, it will be appreciated that solid members with integral spherical/shaped ends may be used, as well as the telescoping and other configurations disclosed with reference to the various alternative embodiments.

[0143] FIG. 3B is a detail drawing of a single-opening connector according to the invention, and FIG. 3C is a top-down view of the single-opening device of FIG. 3B. The structure 20 includes a rod-receiving body 22 coupled to a pedicle screw 24. The body includes one opening 23 configured for a constrained connection and a second opening 25 adapted for multiple degrees of freedom before compression fastener 28 is tightened into threaded area 30. To provide a solid mass, tension band 26 is positioned onto recesses 27 before tightening fastener 28. FIG. 3C shows the recesses 27 from above, as well as the bottom of hemispherical well 34 within the body 22.

[0144] FIG. 3D is a detail drawing of a multiple-opening connector 40 according to the invention, and FIG. 3E is a top-down view of the multi-opening device 40 of FIG. 3D, in this case a two-port device. The structure 40 includes a rod-receiving body 42 coupled to a pedicle screw 44. The body 42 includes one opening 43 configured for a first rod moveable in multiple dimensions, and a second opening 45 for a second rod, also adapted for multiple degrees of freedom before compression fastener 28 is tightened into threaded area 50. To provide a solid mass, a tension band 26 is positioned onto recesses 47 before tightening fastener 28. FIG. 3E shows the recesses 47 from above, as well as the bottom of the hemispherical well within the body 42. Note that in the preferred embodiment the same tightening band 26 and setscrew 28 may be used for both the single and multiple opening configurations.

[0145] FIG. 3F is a cross-sectional drawing of the preferred compression fastener, in this case a setscrew 28 having an allen-wrench-receiving top portion 62 and a hemispherical bottom portion 64.

[0146] FIG. 3G is a drawing which shows the way in which caps may be added to elongated members according to the invention to produce spherical or semi-spherical endings. FIG. 3H shows the way in which multiple elongated members may be interconnected to produce a single spherical or semi-spherical joint region. In the preferred embodiment, link members 80 have male/female half spheres allowing either caps or additional rods to be attached. This not only reduces the number of devices on the surgeon's tray, but it also allows two rods to form a single ball unit for a smaller profile.

[0147] In FIG. 3G, end 82 includes a male post 83, which receives end cap 84 having female aperture 85. The other end of the rod functions in like manner, with the male and female roles reversed. Although the posts and apertures are not technically necessary, they do allow the surgeon to

pre-assemble components which hold together prior to installation, thereby maximizing the use of both hands. As shown in FIG. 3H, two rods may be connected to one another as opposed to the end caps, thereby allowing the fastener of FIGS. 3D and 3E to have rods extending from both sides. Note that the rods of FIG. 3H may be turned at the joint region prior to installation, thereby permitting the rods to extend from the connector of FIGS. 3D and 3E at various angles prior to tightening.

[0148] FIG. 3I illustrates an alternative connector system according to the present invention. A pedicle screw 302 having a hemispherical head 303 and a slot 306 (or alternatively a hex head or other suitable tool-engaging feature) is driven into the vertebrae at points useful for alignment. A connector body 204 is placed over the exposed end of the screw 302 so that the head 303 engages with a corresponding opening 304 in the bottom of the connector. A setscrew 307 or other fastener is used to lock the body 204 in place relative to screw 302 and vertebrae to which it is attached. At this point, the body 204 is able to swivel in three dimensions until the devices are locked into place.

[0149] Link bars 206, preferably with enlarged ends are placed into recesses 308 into the body 204, and these are locked into place with setscrews 312 or other suitable fasteners. Again, until the setscrews 312 are tightened down, the links 206 may have at least some play until locked into place. Although short bars 206 of equal length are illustrated, it will become apparent that the system is quite flexible, and may take advantage of bars of different or adjustable lengths and profiles. An aperture such as 314 may be provided to enable a tool to move the connectors into a desired position, or remove the body 204 from the screw 302, as appropriate.

[0150] FIG. 3J illustrates an alternative embodiment of the invention, wherein the swivel joint between the pedicle screw and connector body is replaced with a screw 402 having a threaded end 406. The threaded end 406 now protrudes through a larger hole 414 in the connector body 404, enabling a nut 407 or other suitable fastener to lock the body 404 onto the screw 402. Similar to the embodiment of FIG. 3A, however, link bars 206 fit into recesses 408 in the body 404, and set screws 412, which mate with threads 410, are similarly used to lock the link bars into place once a desired orientation is achieved.

[0151] FIG. 3K is a side view of a preferred transverse connector according to the invention. FIG. 3L is a top view of the transverse connector of FIG. 3K, showing how bodies 92 clamp onto rods 90. FIG. 3M is a top view of the transverse connector of FIG. 3K, illustrating multiple degrees of freedom made possible by the arrangement. FIG. 3N depicts multiple views of the preferred transverse connector of FIG. 3K, showing various degrees of angulation. FIG. 3O illustrates the use of a ball joint that permits the preferred transverse connector to accommodate non-parallel rods. FIG. 3P is an end view of the preferred transverse connector used to illustrate the desirability of reduced dimensions. In particular, dimensions X and Y are both reduced according to the invention, and fastener 96 is not engaged until the two halves of the unit are brought into close proximity.

[0152] FIGS. 4A and 4B are drawings of improved sub-laminar hooks constructed according to the invention. Broadly, these devices include bodies such as 442 having a recess such as 443 configured for engagement with sub-lamina, but in contrast to existing devices, either a hemi-

spherical connector **444** or threaded connector **446** are provided on the body to engage with the inventive link connectors discussed, for example, with reference to FIGS. **3A** and **3B**. FIG. **4C** illustrates a sublaminar hook embodiment of the invention featuring two opposing spherical joints. FIG. **4D** illustrates a sublaminar hook embodiment of the invention featuring a single spherical joint.

[**0153**] FIGS. **5A** and **5B** illustrate, respectively, two ways in which connectors according to the invention may be cross-linked, with the understanding that additional variations are certainly possible. In FIG. **5A**, longer link members **502** are used to link the sides of the connector in crisscross fashion, whereas, in FIG. **5B**, shorter link members **504** are used in a manner transverse to those oriented from foot-to-head along the spine. Note also that the plate and rod connectors may be used separately or together; that is while it may be advantageous to use plates at **502** and **504** for transverse interconnection, spherical joints may be preferred longitudinally along the spine, as in locations **510**.

[**0154**] FIGS. **6A-6C** illustrate the way in which instrumentation may be used to obtain a desired degree of vertebral correction, at which time the link members may be added to maintain the structure in correct alignment. In FIG. **6A**, vertebrae **610** and **620** are mal-aligned, and instruments **602** and **604** are used to adjust them into a proper orientation. Generally speaking, instrument **602** is used to urge apart the connectors **612**, **622** shown in the left part of the drawing, where the vertebrae are too close to one another, whereas instrument **604** is used to pull the vertebrae together.

[**0155**] FIG. **6B** is a drawing which shows a desired orientation of the connectors **612** and **622**, without the vertebrae being shown, and FIG. **6C** illustrates how, having achieved a desired final position, link members **630** and **632** are tightened onto the connectors **612** and **622**, at which time the instruments may be removed. This process is more or less repeated, on adjacent vertebral levels, until an overall desired level of alignment is achieved. Given the ease with which the link members and the connectors themselves may be readjusted, the surgeon may readily go back over areas in need of further refinement, as appropriate.

[**0156**] This process is shown in FIGS. **7A** through **7D** with respect to the restoration of a frontal alignment. In FIG. **7A** the spine is curved as shown, with seven connectors being positioned by the surgeon on the various vertebrae to begin the correction process. In FIG. **7B**, the connectors shown upwardly in the drawing are first brought into alignment, and in FIG. **7C**, cross-links and additional link members have been added further down the spine. In FIG. **7D**, all of the connectors are linked up, with fine adjustments being made in three dimensions, as necessary, for a desired degree of correction. Again, although two rod-receiving positions are shown with respect to each body, use of the bodies and link members of FIGS. **3D** through **3H** would proceed in like fashion.

[**0157**] In restoring the frontal alignment just described, the manual instruments of the type shown in FIGS. **6A-6C** would be appropriate, though they are not shown in FIGS. **7A-7C**. To restore sagittal alignment, a different form of instrument is preferred, to raise and lower connectors as opposed to pushing and spreading. Instruments according to the invention for this purpose are shown in FIGS. **8A-8C**. In FIG. **8A**, a tool **802** is inserted into connectors **804** and **806**, and in FIG. **8B**, the connectors are brought into sagittal alignment. In FIG. **8C**, a link member **810** is fastened to the connectors, and the tool **802** removed.

[**0158**] In all of the rod-receiving bodies described herein, small apertures or slots may be provided to receive a tool for corrective positioning and, with the aid of a specialized instrument such as **900** depicted in FIG. **9**. Using such a tool, the body may be removed from the ball-tipped hooks or pedicle screws previously described, as appropriate. Such a tool would preferably include side portions **902** and a central pin **906** which may be forced down through the opening **314** by handle **910**, thereby applying force between the body and hook or screw to remove the connector for repositioning or removal.

[**0159**] FIG. **10** is a side-view drawing of an alternative connector system according to the invention, wherein angled, preferably reinforced components **1002** are fastened to pedicle screws **1004**. The members **1002** provide one or more holes, better seen in FIGS. **11** and **12**, to which link members such as **1110** may be fastened. Note that the pieces **1102** would preferably be provided in various heights and sizes better accommodate a given patient physiology.

[**0160**] FIG. **11A** shows one way in which the connectors introduced with respect to FIG. **10** would be used in practice. Six connectors such as **1102** are shown, each having four holes to receive link bars. With this many fastening points, multiple reinforcements may be used. In particular, both lateral and diagonal cross members are readily accommodated. Moreover, as shown in FIG. **11B**, the holes may be used for devices other than the link members. For example, cables **1110** may be used where appropriate, and in some cases may be wrapped around the lamina (sublaminally) as depicted with numerical reference **1112**.

[**0161**] Rigid link members and cables may also be used with the alternative connector **1202** of FIG. **12A**, which includes holes **1204** on one side for link bars and additional holes **1206** on the other side for cables. FIG. **12B** shows the alternative connector of FIG. **12A** in use, with a combination of cables **1216** and rigid link members **1214** (shown as lines) being used to establish a stable, cross-coupled structure.

[**0162**] FIG. **13** illustrates an alternative arrangement according to the invention, wherein cables **1302** are applied to an existing rod/plate system to impart further structural integrity. Four diagonally oriented cable paths are used, though more or fewer may be employed, depending upon the needs of the patient. In contrast to interconnection of the cables to the rods themselves, as shown in FIG. **13**, cables **1402** may be applied to the screws **1406** binding the rods to the vertebrae, as shown in FIG. **14**.

[**0163**] FIGS. **15A** and **15B** illustrate yet a further, different embodiment of the invention, wherein a rigid link bar **1502** is attached to pedicle screws **1504** using nuts **1506** or other appropriate fasteners. With a sufficiently long exposed threaded end, multiple link members may be used in conjunction with each pedicle screw in a stacking arrangement, thereby allowing for a criss-crossed structural assembly, as shown in FIG. **15B**.

[**0164**] As opposed to rigid link members of a fixed length, the invention also anticipates the use of telescoping members, including the type shown generally at **1700** in FIG. **17**. Each end of such a device would include a flat plate, ball, or fastener such as **1702** and **1703** appropriate to one of the connector systems disclosed herein, but with the length being variable in telescoping or sliding fashion. Preferably, one or more setscrews **1704** would be used to lock the member in accordance with a desired length at any time, including in the midst of an adjustment procedure. Any

cross-sectional geometry may be used, so long as a telescoping action is provided. In particular, whereas a cylindrical geometry may allow for twisting as well as extension prior to locking in place, non-circular cross-sections may be used to permit extension/contraction without twisting, as desired.

[0165] FIGS. 18A-18C illustrate a sublaminar connector 1800 according to the invention, having discs 1802, preferably that swivel, to which the telescoping rods of the type shown in FIG. 17 may be adjustably attached. FIG. 18A presents one view of such a device, showing a lower hook 1820 adapted for sublaminar engagement. FIG. 18B shows a top-view of the device, and FIG. 18C is a cross-sectional view, with arrows used to indicate the preferred swivel action.

[0166] FIG. 19 is a drawing of a further alternative device 1900 having connectors 1902, which also preferably swivel, but include a pedicle screw 1904 for fixation as opposed to a sublaminar engaging portion, as shown in FIGS. 18A-18C. Note that although the body of the device 1900 is depicted integrally with the pedicle screw 1904, the body may be connected to lower screw portion through a connector shown with broken lines at 1910.

[0167] Installation and operation of the devices of FIGS. 18 and 19 are shown in FIGS. 20 and 21, incorporating the sublaminar device of FIG. 18, pedicle screw unit of FIG. 19, and threaded rod of FIG. 23. FIG. 20 is a lateral view of an assembly utilizing these devices, whereas FIG. 21 is a posterior-anterior view.

[0168] A preferred way in which the telescoping rods and fixation devices discussed above will now be described to align a problem with curvature. In FIG. 22A, a telescoping rod 2202 is sized relative to a pair of connectors 2204 and 2204' to be aligned, with fasteners 2206 with nuts 2208 being provided for tightening purposes. FIG. 22B shows the telescoping rod 2202 attached to the connectors 2204, with the arrows being indicative of the way in which the segments of the rod are moved to displace the connectors prior to tightening. FIG. 22C shows how the segments of the rod are locked onto the connectors in an extended position, enabling the vertebrae to be distracted and aligned. It will be clear to one of skill that, as opposed to extension, the segments of the rod 2202 may be brought together, as the case may be, to provide a desired amount of compression.

[0169] FIG. 23 is a side-view drawing of a preferred cross-connector 2300 according to the invention, which may be used in conjunction with, or in place of, the extensible rods just described. The assembly includes a threaded rod 2300, onto which the preferably swiveling attachment mechanisms 2304, 2304' of the connectors are journaled. On either side of the connectors, washers such as 2306, 2306' and nuts such as 2308, 2308' are also preferably used for a precise, yet stable alignment when tightening.

[0170] Although the telescoping and threaded rods have thus far been depicted as straight, they may be curved or bent for different situations. In the case of the telescoping rod, both ends may additionally be adjustable, as shown in FIG. 24. The connector bodies may be attached to the rods such as 2500 in various ways, including the use of a set screw 2502 or other fastener, as shown in the cross-section of FIG. 25.

[0171] FIGS. 26A-26C illustrate an alternative interconnection mechanism that may be used in conjunction with, or in place of, the circular swivel-type connectors described

above. In this case, the connectors bodies 2602, 2602', which may feature pedicle screws or sublaminar hooks 2608, as shown, would include one or more posts such as 2620 extending therefrom, onto which elongated elements 2630 having closed-fork ends such as 2632, 2632' would be journaled, adjusted, then tightened for a desired level of alignment. Although a telescoping rod is shown, threaded arrangements should also be apparent to those of skill, as described above with reference to the swivel-type arrangements.

[0172] FIG. 26A shows a telescoping version of this embodiment prior to placement onto bodies 2602, 2602'. FIG. 26B shows the fork-shaped ends 2632, 2632' being placed onto the posts, and FIG. 26C shows the way in which the ends are tightened onto the posts, preferably through the use of a set screw 2608 which applies pressure to the cylindrical portion of the hook to lock it into position. The setscrews are locked onto the connectors to avoid the frustration of inserting the setscrew into a small space on the hook itself. Using the arrangement of the invention, the setscrews may be tightened or loosened, but will not be removed from the connector and inadvertently lost. Preferably, the cylindrical projections from the hook or pedicle screw bodies have an enlargement at their ends to help prevent the connector from sliding off the hook once it is tightened in place.

[0173] FIG. 27 is a top-view drawing of an alternative connector adapted for use with any of the swivel-type embodiments described herein, the configuration permitting variable angulation in two additional planes. FIG. 28 is a further adaptation of the device of FIG. 28, also providing lockable angulation with multiple degrees of freedom.

[0174] FIGS. 29A and 29B depict an alternative connector system according to the present invention. Broadly, the system uses a ball-shaped connector 2902 on a rod 2904 or other member, wherein the spherical end 2902 fits into a socket 2906 on member 2908. Journaled over the element 2904 is a threaded nut 2910 which engages with threads 2912 on element 2908, thereby locking the device into a desired orientation, as shown in FIG. 29B.

[0175] FIG. 30A shows an embodiment of the invention wherein a connector body and elongated element are integral, providing a low-profile solution particularly for shorter interconnections. Longitudinal member such as 3002 is incorporated into the connector to facilitate insertion into adjacent vertebrae. As such, the combined unit is inherently shorter. Also, note that the connector on the middle screw 3004 is attached to the pedicle screw through a threaded post. Once again, this shortens the unit, particularly in areas of the spine where the attachments to the vertebrae are farther apart and where more spinal deformity may be present. Multiple connectors may also be used to increase the allowed angulation between vertebrae, as shown in FIGS. 30B and 30C.

[0176] FIG. 31A shows swiveling socket-type connectors on a body attached to a pedicle screw. FIG. 31B shows the arrangement of FIG. 31A in an assembled condition. FIG. 31C is a top view illustrating the swiveling feature of the embodiments of FIGS. 31A and 31B. Such swivel connectors may also be incorporated into a sublaminar hook configuration. Hooks and sublaminar attachments do not require the connector-connector feature, however, since devices of this type are slid into position. FIG. 32, for example, shows a sublaminar hook having outward projections to receive the swivel connectors.

[0177] FIG. 33A is a drawing of a top view of a screw connector having two posts. FIG. 33B is a top view of a screw connector according to the invention having a single post. FIG. 33C is a top view of a hook connector. FIG. 33D is an oblique drawing which shows a preferred use of frictional surfaces to lock in the swivel action upon achieving a desired orientation. The friction surface may also be incorporated between the connectors and the screws or hooks. FIG. 33E shows how a setscrew (or setscrews) may be added to help control rotation of a connector according to the invention.

[0178] The combined longitudinal member-connector unit may feature a variety of lengths for the longitudinal members, as well as angles between the longitudinal member and connector. FIG. 34A, for example, shows how a combined longitudinal member and connector may have a particular length and angle to address a particular situation. FIG. 34B illustrates an assembled version of the angled unit of FIG. 34A.

[0179] FIG. 35 is a series of drawings that show a variety of longitudinal members in straight and curved configurations. The longitudinal members shown in FIG. 35 are preferably pre-fabricated in various sizes and shapes with the nuts attached. They are used when the space between the attachment sites on the vertebrae are close together. Depending upon material choice, they may be further bent by the surgeon at the time of surgery as necessary. When the space between the vertebrae attachment sites is larger than the telescoping longitudinal member, a turnbuckle-like longitudinal member would preferably be used. It will be appreciated that these and other ball-ended configuration may incorporate the cap configurations of FIG. 3G.

[0180] The telescoping/turnbuckle members with nuts could also be assembled by the surgeon. For example, FIG. 36A shows how a telescoping member may be assembled through a pair of nuts then joined. FIG. 36B shows a joined assembled version of the assembly of FIG. 36A.

[0181] The cross-links may also be attached to the top of the central posts in many different configurations. FIG. 37 illustrates a plate-like embodiment of the cross-link. This embodiment shows only one cross-link end per connector. For more rigidity, the cross-links could be stacked. For example, FIG. 38 shows an embodiment with two cross-link ends per connector. The longitudinal members and connectors are not drawn in order to better illustrate the cross-links, which are preferably thinner than the rigid longitudinal members in FIGS. 14 and 15. FIG. 39 is a side view of a connector including a cross-link.

[0182] This section of the description provides details of various connector configurations according to the invention, including designs particularly suited to different vertebral levels. In the accompanying drawings, the central connector bodies are threaded at the ends where engage with the longitudinal members. As discussed elsewhere herein, the central connectors may be threaded on either end, though the connectors at the end of a construct are preferably threaded on one end only. The central portion of the connector may include a flat surface, or may be square or rectangular to accommodate a wrench to stabilize the connector while tightening the nut and facilitate attachment to pedicle screw. The central portion of the connector may further include a pedicle hole to attach the connector to a pedicle screw. A friction surface may be provided between the connector (interior surface) and the pedicle screw superior surface.

[0183] FIGS. 40A-40F provide different views of a central lumbar connector according to the invention. In the lumbar

region in particular, the connectors should be as short as possible. The pedicle screws may be 3 cm apart or closer. In this and in other embodiments, a friction surface may be provided between the rod ends and the connector seat. The connectors should be as small as possible in every dimension, since prominent hardware could cause the patient to experience pain.

[0184] FIGS. 41A-41G depict different views of a connector adapted to the cephalad end. As shown in FIGS. 41B and 41G, in particular, such connectors may have a special shape to avoid impingement on the first mobile facet joint of the spine. This is perhaps better visualized in FIGS. 58A and 58B. Note that if the inferior surface has a friction surface left and right units may be provided. Without a friction surface, however, the connector may be turned over for the other side. A special wrench (not shown) may also be provided to hold the connector while tightening the nut. The wrench could be the female version of the non-threaded portion of the connector attached to a handle.

[0185] The caudal end may use same connector as used in cephalad end. A reduced profile is not necessary, and the connector is similar in every other way to the cephalad connector. These connectors may also be used in other positions in patients with spinal deformities. Two connectors will preferably be used per pedicle screw or hook. The portion of the connector that attaches the hook or screw should be as small as possible to allow the connector to rotate. The connector should be as strong as possible to prevent fatigue fracture. If the connector is strong enough, it could also be used in the lumbar spine rather than the end connectors described above. This arrangement could reduce manufacturing costs by using a single type of end connector.

[0186] FIGS. 42A-42E show different views of a thoracic connector according to the invention. FIGS. 43A and 43B show exploded and assembled views, respectively, of sublaminar hooks with thoracic connectors attached thereto. FIGS. 44A-44C are top views showing swiveling before and after locking into a straightened configuration. The connectors rotate until tightening to allow for spinal deformity. They can be loosened and retightened to provide a desired level of correction.

[0187] FIG. 45 illustrates a pedicle screw used to discuss different sizes and diameters according to the invention. In the preferred embodiments, the pedicle screws feature a tapered minor diameter. Most screws break at the connection to the rod, since the bone near the tip of the screw is cancellous, whereas bone near the connector end is cortical. The deeper thread near the tip and constant major diameter for most of the screw serves to enhance pullout strength. However, relatively blunt tips are preferred to avoid vascular injury if the screw tip extends through the vertebra. Generally a tap is used to provide a pathway for the screw. The bone is soft and some surgeons avoid the tapping step. Often a surgeon uses a tap for a 5.5 mm screw but insets a 6.5 mm screw.

[0188] FIG. 46 is a perspective view of the pedicle screw of FIG. 45 including a ball connector and link bar. FIG. 47 is a drawing of the configuration of FIG. 46 in an assembled state. FIG. 48 is an assembled connector having two opposing ball-receiving sockets. Note that pedicle screws for independent double connectors may require a different (i.e. longer) design. FIG. 49 is a drawing of an exploded and assembled view of a pedicle screw having independent double connectors. FIG. 50 shows how a non-round interconnection may be used to prevent rotation of the pedicle screw relative to a connector body.

[0189] This invention also provides 'open' pedicle screws which may be deployed when there is not enough room at 5100 between screws to allow connectors, as shown in FIG. 51. FIG. 52A shows such a hinged connector in an open condition, whereas FIG. 52B shows the hinged connector locked onto a rod. Indeed, it will be appreciated that most, if not all, of the various embodiments described herein may, at least in some way, be adapted for use with spinal rods of the type now in common use.

[0190] FIGS. 53A-53M illustrate the alternative use of straps according to the invention for rod movement and stabilization. FIG. 53A depicts a pedicle screw 5300 having lower threads 5304 and body 5302 with rod-receiving area 5306 and threads 5308 for a compression fastener (not shown). An indentation 5310 is provided on the side for grasping. Typically, surgeons force spinal rods into such pedicle screws and vertebral hooks with bulky clamps and threaded "rod pushers" as depicted schematically in FIG. 53B. This presents significant disadvantages. For one, the clamps and rod pushers are bulky. The large clamps and pushers also frequently impinge on one another. To avoid impingement, surgeons often place excessive force on a single screw or hook to allow placement of a setscrew to hold to hold the rod in place, enabling the surgeon to remove the clamp. The excessive force on a hook or screw can crack the vertebra, and the bulky clamps may interfere with setscrew placement.

[0191] The embodiment depicted in FIGS. 53D-53M uses wires, cables, or straps to guide spinal rods into pedicle screws and hooks. The preferred embodiment uses plastic straps or cable ties 5344 as tightening tools. FIG. 53D shows the use of a strap piece 5340 for such a purpose. As shown in FIGS. 53E and 53F, the strap piece 5340 is preferably rotatable beneath the body of the rod fastener. As depicted in FIG. 53L, the straps may be removed once the rod is held in place with setscrews or nuts.

[0192] FIG. 53G shows a cable tie 5344 engaged with the strap piece 5340 prior to tightening. FIG. 53H shows the cable tie tightened and the rod in place within the pedicle screw. FIG. 53I shows the alternative use of a removable strap piece 5350. FIG. 53J shows a cable tie 5344 engaged with the strap piece 5350 prior to tightening. FIG. 53K shows the cable tie tightened and the rod in place within the pedicle screw. FIG. 53M shows how this and other aspects of the invention are not limited to pedicle screws, but may also be configured for sublaminar hooks and other devices.

[0193] The use of cable ties and straps has several advantages. The straps are less bulky than the clamps and pushers currently in use. Straps, with locking mechanisms, hold tension after the tightening tool is removed. As such, the tightening tool can be removed from the wound, giving the surgeon more room to work. Straps can be tightened repeatedly as the rod advances into several hooks or screws. Thus, the loads are shared by multiple spinal attachment sites rather than a single attachment site. Vertebral fracture is therefore less likely. The straps, cables, and wires are lateral to the hook and screw rod connection. Accordingly, the lateral position does not interfere with setscrew placement.

[0194] The elongated members or rods according to the invention may also be provided in a variety of configurations, including solid-, non-telescoping, telescoping, turn-buckle, and different lengths and shapes. The solid rods with spherical ends may be manufactured with the nuts in position, or half washers may be used as shown in FIGS. 56 and 57 to reduce costs. Rods with single spherical end rods may

use nuts added by the surgeon in lengths that may be cut at the time of surgery to customize.

[0195] FIG. 54 is a side view of a turnbuckle rod according to the invention. Preferably, such a device exhibits a contracted length on the order of 3 cm while being expandable to 10 cm or beyond. Many different sizes may be provided as necessary to accommodate a greater range. FIG. 55 shows the combined use of ball-and-socket connectors in conjunction with optional crisscross link bars. Such bars are preferably narrow, on the order of 2 mm thick, in 2 cm-10 cm lengths with 3 mm increments.

[0196] As discussed above, the nuts may be added to solid rods after the rods are manufactured using half- or slotted washers. FIG. 56 shows how a half-washer 5610 may be used in conjunction with a nut opening 5608 that is large enough to slide over the sphere at the end of a rod. FIG. 57 shows an alternative use of a slotted washer 5610 permitting a nut to slide over the spherical end 5604 of a solid rod 5602.

[0197] Prior-art spinal rods, screws, and plates risk impingement on the first mobile facet cephalad to the fusion. For example, the inferior facet of L₄ may impinge on the plate, rod, nut, or connector extending from L₅ to S₁ in a L₅-S₁ fusion. Impingement can lead to pain, facet arthritis, facet fracture, and additional surgery. What is needed is a reduced profile connector to prevent impingement. FIG. 58A shows a modified connector adapted to reduce impingement. FIG. 58B is a drawing of an anti-impingement connector utilizing a ball-and-socket arrangement.

[0198] FIGS. 59A and 59B are different views of a transverse connector according to the present invention. The transverse connector (cross brace) fits on the rods between the hooks. FIG. 60 shows the combined use of transverse connectors and hinged hooks that lock onto a solid rod. The convex solid rod may be placed after the modular system to restore the spine to its proper alignment. The convex rod may include an octagonal or other cross-section to prevent rotation of cross brace on the rod, as shown in FIG. 61. For example, the convex rod may have longitudinal grooves. Such features may travel the length of the rod or be interrupted. FIG. 62A illustrates the use of a continuous shaped rod, in this case having a grooved cross-section. FIG. 62B illustrates how the modification along the rod may be interrupted along its length.

[0199] FIG. 63 shows a bevel connector embodiment according to the invention. Such a connector allows 15-20 (or more) degrees of angulation before tightening. Although this type of connector is used in current spine implants, prior art configurations use only one rod on each side of spine. This embodiment of the invention allows use of multiple rods/side as shown in FIG. 64. Indeed, it is believed that the modular hooks and screws according to the invention represent the only system that allows two rods to be attached to a single rod hook or screw.

[0200] FIG. 65A shows a stabilization clamp for use with various embodiments disclosed herein. FIG. 65B is an end of the configuration of FIG. 65A. FIG. 66A is a different alternative embodiment of a stabilizing assembly, and FIG. 66B is a cross-section of the assembly of FIG. 66A.

[0201] FIGS. 67A-67C illustrate the use of lockable swivel-type connectors 6704, 6704', which may be fastened to one or, preferably a pair, of parallel (or non-parallel) rods 6702, 6702' to provide a desired degree of alignment and correction. This particular embodiment uses a modified hook structure and setscrew arrangement, which may be

moved along the rod, as shown in FIG. 67B, until a desired degree of separation/orientation is achieved, at which point all of the various components may be tightened into place with fasteners 6710, 6710'.

[0202] To ensure stable interconnections that do not loosen through movement or degrade with time, the invention may take advantage of materials and/or geometries to enhance structural integrity. For example, shape-memory technology may be used to assist in locking the screws, rods, caps, joints and other components to one another. Such interfaces may be mobile until body temperature changes the dimensions to promote a tighter fit, where applicable. In addition, particularly with respect to threaded fasteners, the thread sizes may be slightly mismatched to promote a slight galling for an even tighter fit.

[0203] While the present invention has been shown and described in terms of preferred embodiments thereof, it should be understood that this invention is not limited to any particular embodiment, and that changes and modifications may be made without departing from the true spirit and scope of the invention as defined in the appended claims.

What is claimed is:

1. A system for fixing relative to each other the position of a first spinal vertebra and a second spinal vertebra, comprising:

a rigid elongated element having a shaped end and a rod segment, said elongated element dimensioned to span between a first vertebra and a second vertebra and said rod segment including a first rod portion adjacent to said shaped end and a second rod portion located a distance from said shaped end;

a first connector anchorable to said first vertebra and having a receiver portion, said receiver portion including a peripheral body formed about a space for receiving said shaped end of said elongated element and a surface within said space, said surface being complementary to said shaped end, and said peripheral body having at least one trough for passage of said first rod portion when said shaped end is received within said space and inner threading for complementary engagement with external threading on a first fastener for locking said shaped end within said space;

a second connector anchorable to said second vertebra and having a receiver portion configured to receive said second rod portion and engage a second fastener for locking said second rod portion to said second connector.

2. The system of claim 1, wherein said shaped end is at least partially spherical.

3. The system of claim 1, wherein said surface of said receiver portion is at least partially spherical.

4. The system of claim 1, wherein said surface of said receiver portion and said shaped end form a ball-and-socket.

5. The system of claim 1, wherein said at least one trough has a curved surface.

6. The spinal alignment system of claim 1, wherein said first and second vertebrae are at adjacent vertebral levels within the spine.

7. The spinal alignment system of claim 1, wherein said first and second vertebrae are not at adjacent vertebral levels within the spine.

8. The spinal alignment system of claim 7, further including a third connector anchorable to a third vertebra located between said first vertebra and said second vertebra, said connector having a receiver portion configured to receive a third rod portion located between said first rod portion and said second rod portion and to engage a third fastener for locking said third rod portion to said third connector.

9. The system of claim 1, further comprising:

a second elongated element dimensioned to span between said first vertebra and said second vertebra on the opposite side of said first and second vertebra from said first elongated element; and

a second pair of a connectors anchorable into said first and second vertebrae, and receiver portions configured to receive said second elongated element

10. The spinal alignment system of claim 9, wherein said first elongated element and said second elongated element are connected by a transverse connector.

11. The spinal alignment system of claim 10, wherein said second elongated element is one of generally parallel and not generally parallel to said first elongated element.

* * * * *