

(19) World Intellectual Property Organization
International Bureau



(43) International Publication Date
31 May 2007 (31.05.2007)

PCT

(10) International Publication Number
WO 2007/061455 A1

- (51) International Patent Classification:
A61F 2/44 (2006.01)
- (21) International Application Number:
PCT/US2006/027608
- (22) International Filing Date: 14 July 2006 (14.07.2006)
- (25) Filing Language: English
- (26) Publication Language: English
- (30) Priority Data:
11/273,299 14 November 2005 (14.11.2005) US
- (71) Applicant (for all designated States except US):
OUROBOROS, INC. [US/US]; 15920 Bernardo Center Drive, San Diego, CA 92127 (US).

- (81) Designated States (unless otherwise indicated, for every kind of national protection available): AE, AG, AL, AM, AT, AU, AZ, BA, BB, BG, BR, BW, BY, BZ, CA, CH, CN, CO, CR, CU, CZ, DE, DK, DM, DZ, EC, EE, EG, ES, FI, GB, GD, GE, GH, GM, HN, HR, HU, ID, IL, IN, IS, JP, KE, KG, KM, KN, KP, KR, KZ, LA, LC, LK, LR, LS, LT, LU, LV, LY, MA, MD, MG, MK, MN, MW, MX, MZ, NA, NG, NI, NO, NZ, OM, PG, PH, PL, PT, RO, RS, RU, SC, SD, SE, SG, SK, SL, SM, SY, TJ, TM, TN, TR, TT, TZ, UA, UG, US, UZ, VC, VN, ZA, ZM, ZW.
- (84) Designated States (unless otherwise indicated, for every kind of regional protection available): ARIPO (BW, GH, GM, KE, LS, MW, MZ, NA, SD, SL, SZ, TZ, UG, ZM, ZW), Eurasian (AM, AZ, BY, KG, KZ, MD, RU, TJ, TM), European (AT, BE, BG, CH, CY, CZ, DE, DK, EE, ES, FI, FR, GB, GR, HU, IE, IS, IT, LT, LU, LV, MC, NL, PL, PT, RO, SE, SI, SK, TR), OAPI (BF, BJ, CF, CG, CI, CM, GA, GN, GQ, GW, ML, MR, NE, SN, TD, TG).

- (72) Inventors; and
- (75) Inventors/Applicants (for US only): **SEGAL, Jerome** [US/US]; 5909 Barbados Place #203, Rockville, MD 20852 (US). **YUREK, Matthew** [US/US]; 12957 La Tortola, San Diego, CA 92129 (US).
- (74) Agent: **KLICPERA, Michael**; P.O. Box 573, La Jolla, CA 92038 (US).

Published:

- with international search report
- before the expiration of the time limit for amending the claims and to be republished in the event of receipt of amendments

For two-letter codes and other abbreviations, refer to the "Guidance Notes on Codes and Abbreviations" appearing at the beginning of each regular issue of the PCT Gazette.

(54) Title: MECHANICAL APPARATUS AND METHOD FOR ARTIFICIAL DISC REPLACEMENT

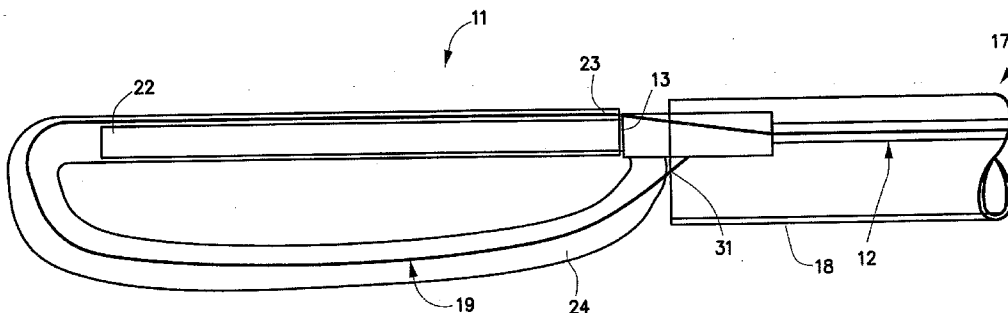

(57) Abstract: The present invention relates to a device and method which may be used to reinforce the native annulus during spinal surgery. The device is a catheter based device which is placed into the inter-vertebral space following discectomy performed by either traditional surgical or endoscopic approaches. The distal end of the catheter is comprised of an expansile loop which may be increased in diameter by advancement of a portion of the catheter via its proximal end, such proximal end remaining external to the body. The expansile loop may be formed of a woven or braided material and may be made of select biocompatible polymer.



WO 2007/061455 A1

MECHANICAL APPARATUS AND METHOD FOR ARTIFICIAL DISC
REPLACEMENT

FIELD OF THE INVENTION

The present invention generally relates to devices and methods for the repair of inter-vertebral discs. More, specifically, the present invention relates to devices and methods for the treatment of spinal disorders associated with the nucleus, annulus and inter-vertebral disc.

BACKGROUND OF THE INVENTION

Inter-vertebral disc disease is a major worldwide health problem. In the United States alone almost 700,000 spine procedures are performed each year and the total cost of treatment of back pain exceeds \$30 billion. Age related changes in the disc include diminished water content in the nucleus and increased collagen content by the 4th decade of life. Loss of water binding by the nucleus results in more compressive loading of the annulus. This renders the annulus more susceptible to delamination and damage. Damage to the annulus, in turn, accelerates disc degeneration and degeneration of surrounding tissues such as the facet joints.

The two most common spinal surgical procedures performed are discectomy and spinal fusion. These procedures only address the symptom of lower back pain. Both procedures actually worsen the overall condition of the affected disc and the adjacent discs. A better solution would be implantation of an artificial disc for treatment

of the lower back pain and to restore the normal anatomy and function of the diseased disc.

The concept of a disc prosthesis dates back to a French patent by van Steenbrugge in 1956. 17 years later, Urbaniak reported the first disc prosthesis implanted in animals. Since this time, numerous prior art devices for disc replacement have been proposed and tested. These are generally divided into devices for artificial total disc replacement or artificial nucleus replacement. The devices proposed for artificial total disc replacement, such as those developed by Kostuik, that generally involve some flexible central component attached to metallic endplates which may be affixed to the adjacent vertebrae. The flexible component may be in the form of a spring or alternatively a polyethylene core (Marnay). The most widely implanted total artificial disc to date is the Link SB Charite disc which is composed of a biconvex ultra high molecular weight polyethylene spacer interfaced with two endplates made of cobalt-chromium-molybdenum alloy. Over 2000 of these have been implanted with good results. However device failure has been reported along with dislocation and migration. The Charite disc also requires an extensive surgical dissection via an anterior approach.

The approach of artificial nucleus replacement has several obvious advantages over artificial total disc replacement. By replacing only the nucleus, it preserves the remaining disc structures such as the annulus and endplates and preserves their function. Because the annulus and endplates are left intact, the surgical procedure is

much simpler and operative time is less. Several nuclear prostheses can be placed via a minimally invasive endoscopic approach. The nucleus implant in widest use today is the one developed by Raymedica (Bloomington, MN) which consists of a hydrogel core constrained in a woven polyethylene jacket. The pellet shaped hydrogel core is compressed and dehydrated to minimize size prior to placement. Upon implantation the hydrogel begins to absorb fluid and expand. The flexible but inelastic jacket permits the hydrogel to deform and reform in response to compressive forces yet constrain the horizontal and vertical expansion (see U.S. Patent No. 4,904,260 and 4,772,287 to Ray). Other types of nuclear replacement have been described which include either an expansive hydrogel or polymer to provide for disc separation and relieve compressive load on the other disc components (see U.S. patent no. 5192326 to Boa). Major limitations of nuclear prostheses are that they can only be used in patients in whom disc degeneration is at an early stage because they require the presence of a competent natural annulus. In discs at later stages of degeneration the annulus is often torn, flattened and/or delaminated and may not be strong enough to provide the needed constraint. Additionally, placement of the artificial nucleus often requires access through the annulus. This leaves behind a defect in the annulus through which the artificial nucleus may eventually extrude compressing adjacent structures. What is clearly needed is a replacement or reinforcement for the natural annulus which may be used in conjunction with these various nuclear replacement devices.

Several annular repair or reinforcement devices have been previously described. These include the annulus reinforcing band described by U.S. Patent No. 6,712,853 to Kuslich, which describes an expansile band pressurized with bone graft material or like, expanding the band. U.S. Patent No. 6883520B2 to Lambrecht et al, describes a device and method for constraining a disc herniation utilizing an anchor and membrane to close the annular defect. U.S. Patent App. No. 10/676868 to Slivka et al. describes a spinal disc defect repair method. U.S. Patent 6,806,595 B2 to Keith et al. describes disc reinforcement by implantation of reinforcement members around the annulus of the disc. U.S. Patent 6,592,625 B2 to Cauthen describes a collapsible patch put through an aperture in the sub-annular space. U.S. Patent App. No. 10/873,899 to Milbocker et al. describes injection of in situ polymerizing fluid for repair of a weakened annulus fibrosis or replacement or augmentation of the disc nucleus.

Each of these prior art references describes devices or methods utilized for repair of at least a portion of the diseased annulus. What is clearly needed is an improved spinal disc device and method capable of reinforcing the entire annulus circumferentially. In addition what is clearly needed is a spinal disc device and method which may be easily placed into the inter-vertebral space and made to conform to this space. What is clearly needed is an improved spinal disc device and method capable of reinforcing the entire annulus that may be utilized either in conjunction with an artificial nucleus pulposis or may be used as a reinforcement for the annulus fibrosis and as an artificial nucleus pulposis.

SUMMARY OF THE INVENTION

The present invention addresses this need by providing improved spinal disc device and methods for the treatment of inter-vertebral disc disease. The improved device and methods of the present invention specifically address disc related pain but may have other significant applications not specifically mentioned herein. For purposes of illustration only, and without limitation, the present invention is discussed in detail with reference to the treatment of damaged discs of the adult human spinal column.

As will become apparent from the following detailed description, the improved spinal disc device and methods of the present invention may reduce if not eliminate back pain while maintaining near normal anatomical motion. The present invention relates to devices and methods which may be used to reinforce or replace the native annulus, replace the native nucleus, replace both the annulus and nucleus or facilitate fusion of adjacent vertebrae. The devices of the present invention are particularly well suited for minimally invasive methods of implantation.

The spinal disc device is a catheter based device which is placed into the inter-vertebral space following discectomy performed by either traditional surgical or endoscopic approaches. The distal end of the catheter is comprised of an expansile loop which may be increased in diameter by either advancement or retraction of a control element comprising a flexible portion of the catheter which may be manipulated by its proximal end, such proximal end

remaining external to the body. The expansile loop may be formed of a woven, knitted or braided material and may be made of Nylon, Dacron, synthetic polyamide, expanded polytetrafluoroethylene (e-PTFE), polyethylene and ultra-high molecular weight fibers of polyethylene (UHMWPE) commercially available as Spectra™ or Dyneema™, as well as other high tensile strength materials such as Vectran™, Kevlar™, natural or artificially produced silk and commercially available suture materials used in a variety of surgical procedures. Alternatively the expansile loop portion of the catheter may be made of a biodegradable or bioabsorbable material such as resorbable collagen, LPLA (poly(l-lactide)), DLPLA (poly(dl-lactide)), LPLA-DLPLA, PGA (polyglycolide), PGA-LPLA or PGA-DLPLA, polylactic acid and polyglycolic acid which is broken down and bioabsorbed by the patient over a period of time. Alternatively the expansile portion of the catheter may be formed from metallic materials, for example, stainless steel, elgiloy, Nitinol, or other biocompatible metals. Further, it is anticipated that the expansile loop portion of the device could be made from a flattened tubular knit, weave, mesh or foam structure.

The expansile loop may be formed such that when the loop is diametrically contracted one end of the loop feeds into its other end, similar to a snake eating its own tail. Alternatively, the expansile loop may be formed such that when it is diametrically contracted it is in the shape of a toroid invaginating into itself. Stabilization of the outer portion of the loop and pulling out the inner portion will thereby increase the overall diameter of the loop.

while maintaining it as a substantially closed loop or toroid.

In one embodiment, the present invention consists of a device and method, whereby the present invention is first delivered and expanded within the vertebral space to the limits of the inner portion of the native annulus to reinforce or artificially replace the native annulus.

In another embodiment, the present invention consists of a device and method, whereby the present invention is first delivered and expanded within the vertebral space to the limits of the inner portion of the native annulus and then an injection of polymeric or hydrogel or like material is conducted to reinforce or artificially replace the native annulus.

In another embodiment, the present invention consists of a device and method, whereby the present invention is first delivered and expanded within the vertebral space to the limits of the inner portion of the native annulus and then the inner portion of the present invention is centrally expanded to the limits of an artificial nucleus concurrently or previously placed within the inter-vertebral space.

In another embodiment, the present invention consists of a device and method, whereby the present invention is first delivered within the vertebral space and into the area of the nucleus, which may have been previously removed, and expanded to the limits of the outer portion of the area of the native nucleus and then injected with a

polymer or hydrogel or like material conducted to reinforce or artificially replace the native nucleus.

In another embodiment, the present invention consists of a device and method, whereby the present invention is first delivered within the vertebral space and expanded within the vertebral space to the limits of the outer portion of the native annulus and then an injection of polymeric or hydrogel material is conducted to reinforce or artificially replace the native annulus. Then the present invention is delivered into the nucleus area and expanded to the limits of the outer portion of the native nucleus or an artificial nucleus concurrently placed and then an injection of polymeric or hydrogel material is conducted to reinforce or artificially replace or reinforce the nucleus.

In another embodiment, the present invention consists of a device and method, whereby the present invention is first delivered and expanded within the vertebral space and expanded inward from the outer limits of the annulus to the point where essentially no central hole remains in the toroid and a polymeric or hydrogel or like material is injected into the expanded mesh.

In another embodiment, the present invention consists of a device and method, whereby the present invention is delivered and expanded within the vertebral space and then an injection of a bone graft material, polymeric bone graft compound, or material inducing or promoting the growth of bone such as, but not limited to growth factors, BMP or like is conducted in order to facilitate the fusion of an adjacent vertebrae.

The present invention and variations of its embodiments is summarized herein. Additional details of the present invention and embodiments of the present invention may be found in the Detailed Description of the Preferred Embodiments and Claims below. These and other features, aspects and advantages of the present invention will become better understood with reference to the following descriptions and claims.

BRIEF DESCRIPTION OF THE DRAWINGS

Figure 1 is a cross-section view of one embodiment of the present invention with the control element attached to the interior distal end of the expansile loop and in a contracted delivery configuration.

Figure 2 is a cross-sectional of one embodiment of the present invention with the control element attached to the interior distal end of the expansile loop and with the sheath retracted and the expansile loop exposed.

Figure 3 is a cross-section view of one embodiment of the present invention with the control element attached to the interior distal end of the expansile loop and with the expansile in an expanded configuration.

Figure 4 is a cross-section of the one embodiment of the present invention with the control element attached to the interior distal end of the expansile loop and with the expansile loop in an expanded and the inner circumference of the expansile loop in a contracted configuration.

Figure 5 is a magnified cross-section view from Figure 4 of the present invention with the control element attached to the interior distal end of the expansile loop and showing the controlling end of the expansile loop.

Figure 6 is a cross-section view of another embodiment of the present invention with the control element exiting the sidewall of the outer section of the expansile loop and releasably connecting to the proximal portion of the outer section of the expansile loop and with the expansile loop shown in a contracted delivery configuration.

Figure 7 is a cross-sectional view of another embodiment of the present invention with the sheath retracted and the expansile loop exposed.

Figure 8 is a cross-section view of the embodiment of Figure 1 with the expansile loop in an expanded configuration.

Figure 9 is a magnified cross-section view from Figure 8 of the present invention showing the controlling end of the expansile loop.

Figure 10 is a cross-section view of another embodiment of the present invention with two control elements and in a contracted delivery configuration.

Figure 11 is a cross-sectional of another embodiment of the present invention with two control elements and with the sheath retracted and the expansile loop exposed.

Figure 12 is a cross-section view of another embodiment of the present invention with two control elements and with the expansile loop in an expanded configuration.

Figure 13 is a cross-section of another embodiment of the present invention with two control elements and with the expansile loop in an expanded and the inner circumference of the expansile loop in a contracted configuration.

Figure 14 is top view cross-section view of a spinal body (vertebrae) showing the posterolateral access tube advanced into the inter-vertebral space.

Figure 15 is a top view cross-section view of a spinal body (vertebrae) with one of the embodiments of the present invention being positioned within the inter-vertebral space of the spinal body (vertebrae).

Figure 16 is a top view cross-section of a spinal body (vertebrae) with one of the embodiments of the present invention expanded and surrounding the nucleus section of the spinal body (vertebrae).

Figure 17 is top view cross-section of a spinal body (vertebrae) with one of the embodiments of the present invention's outside diameter expanded and the inside diameter contracted within the inter-vertebral space of the spinal body (vertebrae).

Figure 18 is a cross-section dimensional view of the expansile loop in a partially expanded configuration with a diameter D and a height H .

Figure 19 is a cross-sectional dimensional view of the expansile loop in an expanded configuration with the diameter increasing $+D$ and the height increasing $+H$.

Figure 20 is a cross-section view of another embodiment of the present invention with the expansile loop in an invaginated configuration (whereby a portion of the expansile loop is bent back and entering itself) with the expansile loop in a partially expanded configuration.

Figure 21 is a cross-sectional view of additional feature of the present invention with an inner catheter or control element having a plurality of holes for delivery and injection of biomaterials.

Figure 22 is a perspective view of an element of the present invention whereby locking elements on the distal end of the expansile interior loop are engaged to the expansile outer loop.

DESCRIPTION OF THE PREFERRED EMBODIEMENTS

One embodiment 10, 11 of the spinal disc device, as shown in Figures 1-5, consists of an elongated probe 15, with a proximal end 17 and a distal end 16. Referring to Figures 1 and 2, it can be seen that the elongated probe 15 is constructed from at least two elements, a flexible inner catheter control element 19, and a stiffer outer catheter element 12. The inner catheter control element 19 is slideably located within the outer catheter element 12. At the proximal end 17 of elongated probe 15, the inner catheter control element 19 exits from the outer catheter element 12, and can be advanced or retracted causing the distal end 20 of the inner catheter control element 19 to move in or out of the distal end 13 of the outer catheter element 12. Near the distal end 16 of the elongated probe 15, is situated an expansile, braided or woven tubular loop 24 in a contracted or delivery configuration (Figure 1). The inner catheter control element 19 enters the expansile loop 24 near the distal end 13 of the outer catheter element 12 and slideably resides within the expansile loop 24. The distal end 22 of the expansile loop 24 is fed into the proximal end 23, of the expansile loop 24 in a manner similar to a snake eating its own tail. This results in an expansile loop 24 with an inner section and outer section as shown in Figures 1 and 2. A covering retractable sheath 18 is placed over the elongated probe 15 to hold it in a constrained condition for delivery into the vertebral disc. After the sheath 18 is retracted, the expansile loop 24 may be increased in circumferential diameter by withdrawing the

distal end 22 of the expansile loop 24 from the proximal end 23 of the outer expansile loop 24 (Figure 3). In this configuration, a substantially continuous interior chamber 28 is now defined within the expanded expansile loop 25. The outer catheter element 12 terminates at its distal end 13 and is removeably attached to the proximal end 23 of the outer section of the expanded expansile loop 25. The inner catheter control element 19, in the form of a filament, guidewire or flexible tube, slideably extends from the proximal end 17 of the catheter or probe 15, through the outer catheter element 12, and exiting the outer catheter element at its distal end 13. The inner catheter element then enters the inside of the outer section of the expansile loop at its proximal end 23. The inner catheter control element 19 may be looped one, less than one, or more than one time within the expansile loop 24, 25 between the inner and outer portions of the loop prior to the inner catheter element 19 or control element terminating within the expansile loop 24, 25 at its distal end 22, 26. The inner catheter control element 19 is then attached to the expansile loop 24, 25 at the distal end 22, 26 of the inner section of the expansile loop 24, 25.

The inner catheter control element can be made of a flexible yet longitudinally incompressible material such as, but not limited to, a stainless steel or Nitinol wire of 0.010"-0.040" diameter. Slidably advancing the inner catheter element 19 through the outer catheter element 12 while holding the proximal portion of the outer section of the expansile loop 23, 27 in place will result in the inner section of the expansile loop 24, 25 pulling out of the outer section of the expansile loop 24, 25. This will

result in the overall diametric expansion of the expansile loop 24, 25. As shown in Figure 4, once expansion of the outer circumference of the expansile loop 25 is achieved and fixed, pulling out the inner catheter control element 19 while holding the outer section 27 of the expansile loop 25 fixed, contracts the inner circumference of the expansile loop 25 while expanding its height. Expansion of the expansile loop 25 into the vertebral space is achieved by the spring nature of the expansile loop's 24, 25 material construction or by advancing the inner catheter control element 19 while holding the proximal outer section of the expansile loop 23 fixed. Next, pulling on the inner catheter control element 19 while holding the proximal outer section 27 of the expansile loop 25 fixed, the interior circumference of the expansile loop 25 contracts toward the center of the expansile loop 25 while the height of the expansile loop 25 increases.

Figure 5 is a magnified cross-section view from Figure 4 of this present invention embodiment with the control element attached to the interior distal end 26 of the expansile loop 25. This Figure shows the controlling end of the expansile loop 25 and the physical relationship between the distal end 20 of the inner catheter 19, distal 26 and proximal end 27 of the expansile loop 25, and outer catheter element 12.

The outer catheter element 12 used for delivery of the expansile loop 24 should be sufficiently stiff to allow retraction of the inner catheter control element 19 without collapse or kinking. The inner catheter control element 19 must be sufficiently flexible to circle around the

expansile loop 24 and attain a relatively small radii without kinking yet have sufficient tensile strength to resist breakage when pulled from its proximal sections. The outer catheter element 12 can be fabricated from polymeric materials including, but not limited to, Nylon, Dacron, synthetic polyamide, expanded polytetrafluoroethylene (e-PTFE), polyethylene and ultra-high molecular weight fibers of polyethylene (UHMWPE), or metallic materials, including but not limited to, stainless steel, cobalt-chrome alloy, titanium, titanium alloy, or nickel-titanium shape memory alloys, among others that have sufficient kink resistance and tensile strength. The inner catheter control element 19 can be manufactured from Nylon, Dacron, synthetic polyamide, expanded polytetrafluoroethylene (e-PTFE), polyethylene and ultra-high molecular weight fibers of polyethylene (UHMWPE) or from metallic materials including, but not limited to, stainless steel, cobalt-chrome alloy, titanium, titanium alloy, or nickel-titanium shape memory alloys, among others. The elements manufactured from metallic materials have a diameter from 0.001" to 0.020" and preferably from 0.004" to 0.010". The elements manufactured from polymeric materials have a diameter from 0.005" to 0.040" and a preferred diameter from 0.010" to 0.020".

The expansile loop 24, 25 is fabricated as a knit, weave or braid and can be constructed from non-degradable materials. Suitable non-degradable materials for the expansile loop 24, 25, include, but are not limited to, Nylon, Dacron, synthetic polyamide, expanded polytetrafluoroethylene (e-PTFE), polyethylene and ultra-high molecular weight fibers of polyethylene (UHMWPE)

commercially available as Spectra™ or Dyneema™, as well as other high tensile strength materials such as Vectran™, Kevlar™, natural or artificially produced silk and commercially available suture materials used in a variety of surgical procedures. The expansile loop 24, 25 fabricated as a weave or braid and can be constructed from biodegradable or bioabsorbable materials. Suitable biodegradable and bioabsorbable materials for the expansile loop 24, 25 include, but are not limited to, resorbable collagen, LPLA (poly(l-lactide)), DLPLA (poly(dl-lactide)), LPLA-DLPLA, PGA (polyglycolide), PGA-LPLA or PGA-DLPLA, and biodegradable sutures made from polylactic acid and polyglycolic acid.

In addition, for some embodiments, suitable metallic materials for the expansile loop 24, 25 may be used that include, but are not limited to, stainless steel, cobalt-chrome alloy, titanium, titanium alloy, or nickel-titanium shape memory alloys, among others. It is further contemplated that the metallic mesh can be interwoven with non-resorbable polymers such as nylon fibers, carbon fibers and polyethylene fibers, among others, to form a metal-polymer composite weave. Further examples of suitable non-resorbable materials include DACRON and GORE-TEX. One feature of the expansile loop 24, 25 is that it needs to have pore sizes or openings that are small enough to hold the filling material or nucleus from extruding out and large enough to maintain flexibility and expansion characteristics.

In another embodiment the distal end 13 of the outer catheter element 12 resides around the inner catheter

control element 19. The outer catheter element 12 is held in a constant relationship or releaseably affixed to the proximal end 23 of the outer section of the expansile loop 24. In this embodiment the inner catheter control element 19 is in the form of a very flexible element which enters the proximal opening in the outside section of the expansile loop 23, loops one, less than one or more than one time around the inside of the outside section of the expansile loop 24 and terminates attaching at the distal end 22 of the inside section of the expansile loop 24. The direction of rotation of the flexible control element 19 (measured from distal end of the control element 20 to the proximal end 21 is in the opposite rotational direction as the direction of rotation of the inside section of the expansile loop 24, as it enters and loops around the outside section of the expansile loop 24. Upon retraction of the proximal end 21 of the inner catheter control element 19, back out of the outer catheter element 12, the distal end 13 of the outer catheter element 12 stabilizes and holds the outer section 23 of the expansile loop 24 in place while the inner section 22 of the expansile loop 24 is pulled out of the outer section, resulting in an increase in the diameter of the expansile loop 24. Once the expanded expansile loop 25 has reached its maximum diameter, determined either by the confines of the space into which it is expanding or by the exit point of the control filament through the proximal end 27 of the expanded expansile loop 25, continued retraction of the inner catheter control element 19 will result in the inner catheter control element 19 producing tension on the inner circumference of the expanded expansile loop 25. The inner circumference of the expanded expansile loop 25 will

contract towards the middle of the expanded expansile loop 25 and the expanded expansile loop's 25 height will increase. Due to the woven or braided nature of the tubular expansile loop 24, 25, the expanded expansile loop 25, will remain generally in the shape of a toroid both upon its circumferential expansion and its central contraction.

An additional embodiment 39, 40 of the expansile loop device used for repair or replacement of the annulus fibrosis of the spine can be understood by referring to Figures 6-9. As shown in Figures 6-8, the inner catheter control element 19 is looped around and exits through the wall of the outer section of the expansile braided loop 24 near the attachment of the outer catheter element 12 to the proximal end 23 of the outer section of the expansile loop 24. The inner catheter control element 19 is then affixed to the outer catheter element 12, at this point using either a knot or a releasable or removable junction or passes proximally through the outer catheter element 12. A covering retractable sheath 18 is placed over the elongated probe 15 to hold it in a constrained condition for delivery into the vertebral disc. After the sheath 18 is retracted, a "snare" or loop is formed by the proximal portion of the inner catheter control element 19 being slideably located within the outer catheter element 12 and the expansile loop 24. If the inner catheter control element 19 is of sufficient stiffness, for example but not limited to, a metallic guidewire of 0.010" - 0.040" diameter, the snare and the expansile loop 24 may be opened by advancing the proximal portion 21 of the inner catheter control element 19 while holding the outer catheter element 12 and the proximal end of the expansile loop 23 in place. This

opening of the circumference of the snare formed by the inner catheter control element 19 will result in an expansion of the circumference of the expansile loop 24 as the inner portion of the expansile loop 24 pulls out of its outer portion. Once the limits of expansion of the expanded expansile loop 25 have been reached, the inner catheter control element 19 may be detached at the junction or connection of the outer catheter 12 and the proximal end of the expanded expansile loop 27 and slideably retracted out of the expanded expansile loop 25 leaving behind a circumferentially expanded expansile loop 25.

In an alternative embodiment of the present invention for annular repair or replacement, the inner catheter control element 19 is run inside of the expansile loop 24, 25 which is looped and exits first the distal end of the inner section of the braided loop 22, 26 and then exits through the wall of the outer portion of the braided loop 23, 27 prior to its attachment to outer catheter element 12. The inner catheter control element or filament 19 may make one, less than one or more than one loop inside of the expansile loop 24, 25 prior to exiting and attaching to catheter element 12. In this manner the inner catheter control element 19 forms a "snare" or loop of one or multiple turns. If the inner catheter control element 19 is of sufficient stiffness, for example but not limited to, a metallic guidewire of 0.010"- 0.040" diameter, the snare may be opened by advancing the proximal portion of the inner catheter control element 21 while holding the outer catheter element 12 and proximal end of the expansile loop 23, 27 in place. This opening of the circumference of one or more loops of the snare formed by the inner catheter

control element 19 will result in an expansion of the circumference of the expansile loop 24, 25 as the inner portion of the expansile loop 24, 25 pulls out of its outer portion. Once the limits of expansion of the expansile loop 24, 25 have been reached, the inner catheter control element 19 may be pulled back into the catheter element 12 by pulling on its proximal portion 21. This causes one or more loops of the snare becoming smaller pulling on the inner circumference of the expanded expansile loop 25 resulting in a contraction of the central space in the middle of the expanded expansile loop 25. Due to the woven or braided nature of the expansile loop 24, 25, the expansile loop 24, 25, will remain generally in the shape of a toroid both upon its circumferential expansion and its central contraction.

As shown in Figures 10-13, another embodiment 43, 44 of the present invention comprises an elongated probe 15, with a proximal end 17 and a distal end 16. Referring to Figures 10 and 11, a first inner catheter control element 19 is slideably located within the outer catheter element 12. At the proximal end 17 of elongated probe 15, the inner catheter control element 19 exits from the outer catheter element 12, and can be advanced or retracted causing the distal end 20 of the inner catheter control element 19 to move in or out of the distal end 13 of the outer catheter element 12. The first inner catheter control element 19, in the form of a filament, guidewire or flexible tube, slideably extends from the proximal end 17 of the probe 15, through the lumen of the outer catheter element 12, and exiting the outer catheter element 12 at its distal end 13. The inner catheter control element 19 then enters the

inside of the outer section of the expansile loop 24 at its proximal end 23. The inner catheter control element 19 may be looped one, less than one, or more than one time within the expansile loop 24 between the inner and outer portions of the expansile loop 24 prior to the inner catheter element or control element 19 terminating within the expansile loop 24. The inner catheter control element 19 is then attached to the expansile loop 24 at its distal end 22. This embodiment also includes a second inner catheter control element 52 which extends from the proximal end 17 of the catheter or probe 15, through the outer catheter element 12, and exiting the outer catheter element 12 at its distal end 13. The second inner catheter control element 52 then enters the outside of the outer section of the expansile loop 24 and is attached to the distal end 22 of the expansile loop 24. A covering retractable sheath 18 is placed over the elongated probe 15 to hold it in a constrained condition for delivery into the vertebral disc. After the sheath 18 is retracted, the second interior catheter control element 52 is pulled back into the outer catheter control element 12 by pulling on its proximal end. This causes the distal end of the expansile loop 22 to be pulled from inside the outer portion of the expansile loop 24 expanding the outer circumference of the expansile loop 24 (See Figure 12). Now referring to Figure 13, the first inner catheter control element 19 may be pulled back into the outer catheter element 12 by pulling on its proximal end. This will result in a pulling in of the center of the expansile loop 25 towards the middle of the loop and contraction of central space in the middle of the expansile loop 25. Due to the woven or braided nature of the tubular expansile loop 24, 25, the expansile loop 24, 25, will

remain generally in the shape of a toroid both upon its circumferential expansion and its central contraction.

In another embodiment 59, 60 as represented in Figures 18-20, the contracted configuration of the expansile loop 58 comprises an expansile loop 58 which has a portion folding back into itself or invaginated 56 (see Figure 20). This forms a complete toroid with a portion invaginated to form a diametrically contracted toroid with an inner section and an outer section that are continuous with each other. Pulling on the inner catheter control element 19 in the manner previously described will function to increase the diameter (+D) and increase the height (+H) of the expanded expansile loop 25 as the central portion of the toroid is pulled towards the center.

The entire expansile loop assembly 10 including the circumferentially contracted braided expansile loop 24, and inner catheter control element 19, may now be compressed into the distal outer catheter element, a sheath 18 or alternatively into an access tube 38 of approximately 3-20mm diameter for ease of placement. The access tube 38 may be formed from any suitable material, as the present invention is not limited in this respect. Thus, the access tube 38 may be formed from a plastic material, such as a polycarbonate, or a metal material, such as stainless steel, or any suitable combination of materials. In addition, the posterolateral access tube 38 may be formed of a material that can be readily sterilized. Further, the elongated probe 15 may be formed as a single use device such that resterilization is not required after use. The

posterlateral access tube 38 gains access to the vertebrae generally using a posterior approach (Figure 14).

As shown in Figure 15, the posterlateral access tube 38 has gained access to the vertebrae 32, having a spinal cord 33, an annulus 36 and a nucleus area 34. Once in proper position in the vertebrae 32 of a patient, the expansile loop 24 may be ejected into the nucleus area 33 or the annulus area (not shown in this Figure) from the distal end of the outer catheter element 13, sheath 18 or access tube 38 by retracting the outer catheter element 12 or sheath 18 and simultaneously holding the inner catheter 19 and expansile loop 24 in a fixed position. Alternatively, an additional "pusher" element (not shown) can be advanced distally into the outer catheter element 12 or sheath 18 or access tube and eject the expansile loop 24, catheter element 12 and the distal inner catheter control element 20 from the end of the sheath 18. As previously described in the embodiments above, the expansile loop 24 may now be circumferentially expanded by either pulling on or pushing the inner catheter control element 19 in the manner described above. Furthermore, if it is desired that the central portion of the braided expansile loop 24 become circumferentially contracted, pulling on the inner catheter control element 19 as described above will accomplish this feature.

Now referring the Figures 16 and 17, the expanded expansile loop 25 achieves the desired outer circumferentially expanded (Figure 16) and partially inner circumferentially contracted size 48 with partially contracted central area 34. In Figure 17, the central

area if fully contracted resulting in a small diameter toroid 37. At this time, the inner catheter control element 19 is locked or tied in place with a knot. This can also be accomplished by a locking junction located at the outer catheter element 12. The distal portions 20 of the external inner catheter control element 19 can now be disconnected or cut from a connector or proximal to the knot. The connector or knot is also separated from the distal outer catheter element 12. This then leaves an outer circumferentially expanded and inner circumferentially contracted expansile loop 25 in place as a closed loop in the desired location (shown in Figure 16 expanded with the nucleus area 34) within the inter-vertebral space.

Now referring to Figure 18 which demonstrates a cross-section dimensional view of the expansile loop in a partially expanded configuration with a diameter D and a height H . In Figure 19 the cross-sectional dimensional view of the expansile loop is in an expanded configuration where a unique characteristic of the present invention expansile loop is demonstrated. When tension is applied to the control element 19, the outside diameter $+D$ expands while simultaneously the height $+H$ is increased (diametrically expansion and contraction). Not shown in these Figures, the present invention can also simultaneously reduce the diameter of the central area 34. The resulting structure includes an internal lumen 28 contained within the expansile loop and a central area 34 surrounded by the expansile loop. Furthermore, expanding the expansile loop with the control element can disproportionately contract said central area 34 whereby

the waist of the central area is constricted to a smaller diameter than the terminal ends.

Figure 20 is a cross-section view of another embodiment of the present invention with the expansile loop in an invaginated configuration (whereby a portion of the expansile loop is bent back and entering itself) with the expansile loop in a partially expanded configuration.

As represented in Figure 21 an additional feature of the present invention with an inner catheter control element 41 having a plurality of distal holes 42 for delivery and injection of biomaterials which can be utilized with the embodiments of the present invention. The inner catheter control element 41 with holes 42 comprises a tubular structure with a central lumen from the proximal end 17 of the outer catheter element 12 communicating with side holes in the distal end 13. The proximal end of the inner catheter or control element may be fitted with an injection device (e.g. syringe). The inner catheter control element 41 is contained within the continuous interior chamber of the expanded expansile loop 58. The holes 42 in the inner catheter control element 41 are designed to be only within the continuous inner chamber. Furthermore, it is anticipated that the holes can be of different size along the length of the inner catheter control element to equalize biocompatible material delivery (e.g. larger holes at the distal end, smaller holes at the proximal end). In addition, it is anticipated that the holes can be in various configurations, e.g. oval, or can be a plurality of slots or other similar opening.

Figure 22 is another feature of the present invention that can be used with several of the embodiments 11, 44, 60, 62 whereby non-permanent locking elements 30 on the distal end of the expansile interior loop are engaged to the distal end 26 of the expansile outer loop. The locking elements are extended portions of one end of the braid or loop which interlock with the braid or loop pattern. The locking elements function to maintain a desired diameter of the expansile loop after expansion.

In one method of clinical use, the nucleus of the damaged disc has been previously removed by discectomy techniques either through an anterior, posterior or posterolateral surgical approach. The expansile loop annular repair or replacement device 10 in its compressed configuration within the outer catheter element 12 or sheath 18 is advanced through an access tube or cannula previously placed into the inter-vertebral space. This cannula may access the inter-vertebral space from a posterior, posterolateral or anterior approach that is well known to physicians skilled in the art. The present invention 10 is then advanced into the inter-vertebral space through the access tube 38. Once the distal expansile loop 24 is advanced through the access tube 38 into the vertebral space it is diametrically expanded by either retraction or advancement of the inner catheter control element 19 in the manner previously described. The distal expansile loop 25 expands to the limits of the inner portion of the remains of the native annulus and remains diametrically expanded and transversely contracted as illustrated in Figure 6. Any of a number of previously

described artificial nuclei puposi may then be placed in the center of the diametrically expanded expansile loop 48 either via direct visualization from the traditional surgical approach or via endoscope from a posterolateral approach through the foramina or form a posterior approach. These artificial nuclei may then be allowed to expand either through the absorption of liquids, as is the case for hydrogel based devices, or through the injection of material into the nuclear prosthesis.

Once the nuclear replacement is in place, any remaining space between the nuclear replacement and the expansile loop annular replacement device may be reduced or eliminated by centrally contracting the inner circumference of the toroid formed by the expansile loop device. This is accomplished in the manner previously described by pulling back the inner catheter control element resulting in contraction of the inner circumference of the device until it abuts the nuclear replacement. The braided design of the expansile braided loop 48 will also allow it to flex and bend to conform to the inter-vertebral space. By properly selecting the material from which the expansile braided loop is constructed and by properly selecting the design of braid for its manufacture as previously described, the expansile braided loop will now function as a complete circumferential support for the artificial nucleus. The expansile braided loop will prevent extrusion of the artificial nucleus through any defects in the remaining native annulus and act to stabilize the artificial nucleus during both bending and motion of the spine and throughout the healing process. The braided design of the expansile loop will also permit it to flexibly bend as the central

nucleus replacement expands and swells to its final size. The braided design of the expansile loop will also permit tissue in growth to occur as healing occurs. This will result in stabilization of the artificial nucleus.

In an alternative method, once the expansile braided loop 48 has been expanded to fill the inter-vertebral space between the artificial nucleus and the native vertebrae and remaining native annulus fibrosis, the expansile loop 48 may be filled with a suitable biologically compatible material. Such suitable materials that can be directly injected through the inner catheter control element 19 if it includes a central lumen and openings connecting with the interior chamber of the expansile braided loop as illustrated in Figure 11. Alternatively, the biocompatible materials can be injected using a separate catheter element which can be advanced along the inner catheter control element into the interior chamber of the expansile braided loop. Alternatively, the biocompatible materials could be injected into the interior chamber of the expansile braided loop using a separate catheter or injection needle which pierces the side of the braided loop once it is expanded and in place in the inter-vertebral space. Biocompatible materials which may be injected include biocompatible viscoelastic materials such as hydrophilic polymers, hydrogels, homopolymer hydrogels, copolymer hydrogels, multi-polymer hydrogels, or interpenetrating hydrogels, acrylonitrile, acrylic acid, acrylimide, acrylimidine, including but not limited to PVA, PVP, PHEMA, PNVP, polyacrylamides, poly(ethylene oxide), polyvinyl alcohol, polyarylonitrile, and polyvinyl pyrrolidone, silicone, polyurethanes, polycarbonate-polyurethane (e.g., Corethane)

other biocompatible polymers, or combinations thereof. The viscosity of the injected fluids must allow them to be injected either via catheter or needle into the braided expansile loop. The injected biocompatible material must cure or polymerize in situ within the expansile braided loop and within the disc space. Such in situ curing of the biocompatible material may be the result of mixing of multiple components and polymerization, temperature change in going from room to body temperature or elevated to body temperature, or other forms of energy such as light or electricity applied to the injected material.

In addition, suitable materials that can be placed directed into the expansile loop 48 and allowed to expand through the absorption of liquids such as water include, but are not limited to, swelling hydrogel materials (e.g. polyacrliamide, polyacrylonitrile, polyvinyl alcohol or other biocompatible hydrogels). Examples of suitable materials for solid or semi-solid members include solid fibrous collagen or other suitable hard hydrophilic biocompatible material. The swelling of these materials may result in further expansion of the expansile braided loop and an increase in the inter-vertebral disc height.

In some cases, a multiphase system may be employed, for example, a combination of solids, fluids or gels may be used. Such materials may create primary and secondary levels of flexibility within the braided expansile loop and within the vertebral disc space.

Once the expansile loop 48 is filled with a suitable material and the material has cured or partially

polymerized, the inner catheter control element or filament 19 can be withdrawn by removing its distal connection to the junction point with the outer catheter element 12 or at its termination within the braided expansile loop and pulling the inner catheter control element out of the expansile loop. Alternatively, the inner catheter control element 19 may be cut off or disconnected at its entry point into the expansile loop. This leaves a complete toroid without defect, formed of the expansile loop in place to act as an annular reinforcement or replacement which may or may not surround an artificial nucleus device.

In another method of clinical use, after the braided expansile loop 48 has been expanded to its maximum diametric dimension, acting as a reinforcement or replacement for the damaged native annulus, the device may be centrally circumferentially contracted, as previously described, to fill any remaining space previously occupied by the native nucleus prior to nucleotomy. The braided expansile loop 48 expands to the limits of the remains of disc space and the remains of the native nucleus and annulus and remains diametrically expanded and centrally circumferentially contracted. Now the braided expansile loop area may be filled with a biomaterial or any suitable material (as described above), as the present invention is not limited in this respect. In addition to the materials disclosed for annulus replacement, additional suitable fluid materials for nucleus and annular replacement include, but are not limited to, various pharmaceuticals (steroids, antibiotics, tissue necrosis factor alpha or its antagonists, analgesics); growth factors, genes or gene vectors in solution; biologic materials (hyaluronic acid,

non-crosslinked collagen, fibrin, liquid fat or oils); synthetic polymers (polyethylene glycol, liquid silicones, synthetic oils); and saline.

Once the expansile loop is filled with a suitable material in the central and circumferentially contracted nuclear area and the annular area, the inner catheter control element 19 can be withdrawn by removing its distal connection to the junction point with the outer catheter element 12 and pulling the inner catheter control element out of the expansile loop. Alternatively the inner catheter control element or filament 19 may be disconnected from its attachment to the distal inner braided expansile loop prior to its removal. Alternatively, the inner catheter control element or filament 19 may be cut off at its entry point into the outer section of expansile loop using a surgical tool. This leaves a complete toroid, without defect, formed of the expansile loop in place to act as an annular and nucleus reinforcement or replacement.

In another method of clinical use, the present invention can be advanced into the vertebral space once a nucleotomy has been performed. Once the braided expansile loop 24 is advanced into the vertebral space, it is diametrically expanded in the manner previously described. The braided expansile loop 25 expands to the limits of the out portion of the remains of the native nucleus and remains diametrically expanded and transversely contracted. Now the braided expansile loop 48 may be filled with a biomaterial of any suitable material, such as those previously noted, as the present invention is not limited in this respect. This injected material is allowed to cure

or polymerize to some extent, and then the central portion of the expansile loop is circumferentially contracted in the manner previously described. At this point the central nuclear area of the vertebral space is filled with the expanded mesh. This central portion can then be filled with biomaterial or any suitable material, such as those previously noted, as the present invention is not limited in this respect. In addition to the materials disclosed for annulus repair or replacement, additional suitable fluid materials for nucleus replacement include, but are not limited to, various pharmaceuticals (steroids, antibiotics, tissue necrosis factor alpha or its antagonists, analgesics); growth factors, genes or gene vectors in solution; biologic materials (hyaluronic acid, non-crosslinked collagen, fibrin, liquid fat or oils); synthetic polymers (polyethylene glycol, liquid silicones, synthetic oils); and saline.

Once the braided expansile loop is filled with a suitable material in the nucleus area, the inner catheter control element 19 can be withdrawn by removing its distal connection to the junction point with the outer catheter element 12 or its distal connection with the distal inner expansile loop, and pulling the inner catheter control element 19 out of the expansile loop. Alternatively, the inner catheter control element or filament 19 may be cut off at its entry point into the expansile loop using a surgical tool. This leaves a complete toroid, without defect, formed of the expansile loop in place to act as an annular reinforcement or replacement and/or nucleus reinforcement or replacement. It also allows the annular area of the device on the periphery and the nucleus portion

of the device in the central region to have different physical properties dependent on the differential biocompatible materials injected into each region.

In an additional method of clinical use, once the nucleus of the disc has been removed, the present invention 10 is advanced into the inter-vertebral space. The braided expansile loop 24 is diametrically expanded in the manner previously described. The distal interior braided expansile loop 25 is pulled out of the outer expansile loop and the overall expansile loop diametrically expands to the limits of the inner portion of the native annulus. Next the inner catheter control element 19 is pulled back out of the expanded expansile loop and the inner portion of the inner catheter or filament loop 19 pulls in the inner circumference of the expansile loop, making the central hole smaller and the braided expansile loop 48 transversely wider to better fill the central defect in the vertebral space. This expanded braided expansile loop 48 may be used to contact a central prosthetic nucleus previously placed in the middle of the braided expansile loop. In the case where no additional nucleus prosthesis is desired, the central portion of the braided expansile loop can be expanded to the point where essentially no central hole 37 remains in the toroid. The fully expanded braided expansile loop can now be injected with a suitable biocompatible material (as described above) which will expand or cure in situ as previously described. In this case the present invention will function as both a prosthetic annulus and a prosthetic nucleus and its load bearing properties will be dependent on the properties of the polymer chosen to fill the expansile loop.

Additionally, a hydrogel, polymer or biocompatible material may be injected into the interior chamber of the expansile loop such that the biocompatible material has the capacity to swell or increase in size as the result of absorbing water or liquid. This would result in further expansion of the expansile braided loop and an increase in the inter-vertebral disc height.

In another method of clinical use, the intended treatment is to fuse two adjacent vertebrae using the present invention 10. Again using the illustration in Figures 10, the end of the inner catheter control element 19 is attached to the interior and distal end 22 of the braided expansile loop 24. To expand the diameter of the expansile loop one merely needs to stabilize the proximal portion or outer end 23 of the braided expansile loop and pull back the inner catheter control element or filament 19 or wire. This will result in the inner section of the braided expansile loop pulling out of the outer section of the braided expansile spiral as the wire is retracted. Once the desired outer diameter of the braided expansile loop 48 is achieved, the central portion of the braided expansile loop 48 may be contacted by pulling the same inner catheter control element 19 further back out of the proximal portion of the braided expansile loop. The inner loop portion of the inner catheter control element or filament 19 will contract in diameter and pull on the inner circumference of the braided expansile loop 48 resulting in the central "hole" of the toroid becoming smaller and smaller in diameter 37. This results in the transverse diameter of the toroid becoming bigger while the outer diameter stays the

same. Once the desired size is reached, the wire may be held in place and a polymeric or other biologically compatible material as describe above injected into the toroid either through the inner catheter control element , which may be in the form of a hollow catheter or hypotube, or alternatively via a catheter which is advanced into the toroid along the inner catheter control element or filament 19 or separately using a catheter or needle for injection. The fully expanded expansile loop 48 can now be injected or filled with a suitable material for fusing the two adjacent vertebrae together. Candidates for a suitable fusing material include, but are not limited to, bond graft materials such as any described "bone cements" or any polymeric bone graft compounds, bone graft materials, nylon fibers, carbon fibers, glass fibers, collagen fibers, ceramic fibers, polyethylene fibers, poly(ethylene terephthalate), polyglycolides, polylactides, and combinations thereof.

Once the bone fusing material has been injected the inner catheter control element 19 may be removed by retracting it from the braided expansile loop. Alternatively, the inner catheter control element 19 may be cut off at its entrance point into the toroid. In another embodiment (not illustrated) the expansile loop may be expanded in diameter using an inner filament of sufficient stiffness such as the metal wire described and the central hole may be made smaller by pulling on a separate flexible filament such as a thread attached to the inner radius of the expansile braided.

In this embodiment of fusing two adjacent vertebrae together, it may be desirable to stimulate growth of bone through the fill material. To facilitate bone integration and growth, the expansile loop should have openings that are more porous. The pores or openings of the expansile loop will have a diameter of about 0.25 mm to about 5.0 mm. The size is selected to allow tissue in-growth while containing the material packed into the expansile loop. It is also contemplated that the expansile loop can be seeded in vitro with bone forming cells, such as osteoblasts, and/or with growth factors. Multiple layers of osteoblast-seeded applications may be stacked on top of one another and further allowed to or encouraged to proliferate. In addition to in vitro seeding of osteoblasts, other treatments for the braided expansile loop are contemplated that also provide an implant that allows for bone in-growth and regeneration of bony tissue. For example, the expansile loop can be coated with a demineralized bone matrix or smeared or coated with an osteoinductive bone paste, such as OSTEOFIL™. In addition, the expansile loop can be coated with collagen, and subsequently soaked in a pharmacological agent such as recombinant human bone morphogenic protein, antibiotic agents, or other similar material.

It should be understood that the foregoing description of the present invention is intended merely to be illustrative thereof and that other embodiments, modifications, and equivalents of the invention are within the scope of the invention recited in the claims appended hereto. Further, although each embodiment described above includes certain features, the invention is not limited in

this respect. Thus, one or more of the above-described or other features of the invention, method of delivery, or injection of biomaterial may be employed singularly or in any suitable combination, as the present invention is not limited to a specific embodiment.

CLAIMS

1. An spinal disc device comprising:

a flexible and expandable expansile loop, said expansile loop having an interior section in slidable cooperation with an outer section, said expansile loop further having an interior chamber;

said outer section of said expansile loop having a inside surface and an outer opening;

said interior section of said expansile loop having an outside surface and a distal end; and

a flexible control element, said control element having a distal end, a distal section, and a proximal section, said distal end of said control element attached to said distal end of said interior section of said expansile loop, said control element looping around said inside surface of said outer section of said expansile loop whereby said distal section of said control element is located within said interior chamber and said proximal section of said control element exits said expansile loop at said outer opening.

2. The spinal disc device as recited in claim 1, further comprising an outer sheath, said outer sheath having an inner lumen.
3. The spinal disc device as recited in claim 2, whereby said spinal disc device is contained within said inner lumen of said outer sheath when said spinal disc device is in a contracted delivery configuration.
4. The spinal disc device as recited in claim 1, wherein said expansile loop is composed of braided material in a tubular form.
5. The spinal disc device as recited in claim 1, wherein said expansile loop is composed from a polymeric material.
6. The spinal disc device as recited in claim 1, wherein said expansile loop is composed from a metallic material.
7. The spinal disc device as recited in claim 1, wherein said control elements are composed from a polymeric material.
8. The spinal disc device as recited in claim 1, wherein said control elements are composed from a metallic material.
9. The spinal disc device as recited in claim 3, wherein said spinal disc device attains an expanded configuration when expelled from said outer sheath.

10. The spinal disc device as recited in claim 1, wherein said expansile loop forms a substantially circular shape when said interior section coaxially engages said outer section.
11. The spinal disc device as recited in claim 1, further comprising an inner chamber which is substantially continuous around said substantially circular shape.
12. The spinal disc device as recited in claim 1, further comprising the function to deliver within said inner chamber a biocompatible material to the inter-vertebral space.
13. The spinal disc device as recited in claim 11, wherein said inner chamber is filled with a polymeric material.
14. The spinal disc device as recited in claim 12, wherein one or more of said biocompatible materials is formed of a material selected from the group consisting of hydrophilic polymers, hydrogels, homopolymer hydrogels, copolymer hydrogels, multi-polymer hydrogels, or interpenetrating hydrogels, acrylonitrile, acrylic acid, acrylimide, acrylimidine, including but not limited to PVA, PVP, PHEMA, PNVP, polyacrylamides, poly(ethylene oxide), polyvinyl alcohol, polyarylonitrile, and polyvinyl pyrrolidone, silicone, polyurethanes, polycarbonate-polyurethane (e.g., Corethane) other biocompatible polymers, or combinations thereof.
15. The spinal disc device as recited in claim 12, wherein one or more of said biocompatible materials is formed of a

material that is allowed to expand through the adsorption of liquids such as water selected from the group consisting of polyacrilamide, polyacrylonitrile, polyvinyl alcohol or other biocompatible hydrogels, solid fibrous collagen or other suitable hydrophilic biocompatible material or combinations thereof.

16. The spinal disc device as recited in claim 12, wherein one or more biocompatible materials is formed of a material selected from the group consisting of steroids, antibiotics, tissue necrosis factor alpha or its antagonists, analgesics, growth factors, genes or gene vectors in solution; biologic materials (hyaluronic acid, non-crosslinked collagen, fibrin, liquid fat or oils); synthetic polymers (polyethylene glycol, liquid silicones, synthetic oils), saline or combinations thereof.

17. The spinal disc device as recited in claim 12, wherein one or more biocompatible materials is formed of a material selected from the group consisting of bone graft materials such as any described "bone cements" or any polymeric bone graft compounds, bone graft materials, nylon fibers, carbon fibers, glass fibers, collagen fibers, ceramic fibers, polyethylene fibers, poly(ethylene terephthalate), polyglycolides, polylactides, and combinations thereof.

18. The spinal disc device as recited in claim 1, wherein said spinal disc device is adapted to promote spinal fixation between two adjacent vertebral bodies.

19. The spinal disc device as recited in claim 1, wherein said spinal disc device is deformable to conform to an interior region of a vertebral disc.

20. The spinal disc device as recited in claim 12, wherein said spinal disc device is adapted to inject a volume of biocompatible material into said inner chamber of said expansile loop until a desired disc height is achieved.

21. The spinal disc device as recited in claim 12, wherein said spinal disc device is adapted to inject an volume of biocompatible material into said inner chamber of said expansile loop until a desired disc pressure is achieved.

22. An spinal disc device comprising:

a flexible and expandable expansile loop, said expansile loop having an interior section in slidable cooperation with an outer section, said expansile loop further having an interior chamber;

said outer section of said expansile loop having a inside surface and an outer opening;

said interior section of said expansile loop having an outside surface and a distal end; and

a flexible control element, said control element having a distal end, a distal section, and a proximal section, said distal end of said control element exits the distal end of said expansile loop and is attached to an outer catheter element.

23. The spinal disc device as recited in claim 22, further comprising an outer sheath, said outer sheath having an inner lumen.

24. The spinal disc device as recited in claim 22, whereby said spinal disc device is contained within said inner lumen of said outer sheath when said spinal disc device is in a contracted delivery configuration.

25. The spinal disc device as recited in claim 22, wherein said expansile loop is composed of braided material in a tubular form.

26. The spinal disc device as recited in claim 22, wherein said expansile loop is composed from a polymeric material.

27. The spinal disc device as recited in claim 22, wherein said expansile loop is composed from a metallic material.

28. The spinal disc device as recited in claim 22, wherein said control elements are composed from a polymeric material.

29. The spinal disc device as recited in claim 22, wherein said control elements are composed from a metallic material.

30. The spinal disc device as recited in claim 24, wherein said spinal disc device attains an expanded configuration when expelled from said outer sheath.

31. The spinal disc device as recited in claim 22 wherein said expansile loop forms a substantially circular shape when said interior section coaxially engages said outer section.
32. The spinal disc device as recited in claim 22, further comprising an inner chamber which is substantially continuous around said substantially circular shape.
33. The spinal disc device as recited in claim 22, further comprising the function to deliver within said inner chamber a biocompatible material to the inter-vertebral space.
34. The spinal disc device as recited in claim 32, wherein said inner chamber is filled with a polymeric material.
35. The spinal disc device as recited in claim 33, wherein one or more of said biocompatible materials is formed of a material selected from the group consisting of hydrophilic polymers, hydrogels, homopolymer hydrogels, copolymer hydrogels, multi-polymer hydrogels, or interpenetrating hydrogels, acrylonitrile, acrylic acid, acrylimide, acrylimidine, including but not limited to PVA, PVP, PHEMA, PNVP, polyacrylamides, poly(ethylene oxide), polyvinyl alcohol, polyarylonitrile, and polyvinyl pyrrolidone, silicone, polyurethanes, polycarbonate-polyurethane (e.g., Corethane) other biocompatible polymers, or combinations thereof.
36. The spinal disc device as recited in claim 33, wherein one or more of said biocompatible materials is formed of a

material that is allowed to expand through the adsorption of liquids such as water selected from the group consisting of polyacrylamide, polyacrylonitrile, polyvinyl alcohol or other biocompatible hydrogels, solid fibrous collagen or other suitable hydrophilic biocompatible material or combinations thereof.

37. The spinal disc device as recited in claim 33, wherein one or more biocompatible materials is formed of a material selected from the group consisting of steroids, antibiotics, tissue necrosis factor alpha or its antagonists, analgesics, growth factors, genes or gene vectors in solution; biologic materials (hyaluronic acid, non-crosslinked collagen, fibrin, liquid fat or oils); synthetic polymers (polyethylene glycol, liquid silicones, synthetic oils), saline or combinations thereof.

38. The spinal disc device as recited in claim 33, wherein one or more biocompatible materials is formed of a material selected from the group consisting of bone graft materials such as any described "bone cements" or any polymeric bone graft compounds, bone graft materials, nylon fibers, carbon fibers, glass fibers, collagen fibers, ceramic fibers, polyethylene fibers, poly(ethylene terephthalate), polyglycolides, polylactides, and combinations thereof.

39. The spinal disc device as recited in claim 22, wherein said spinal disc device is adapted to promote spinal fixation between two adjacent vertebral bodies.

40. The spinal disc device as recited in claim 22, wherein said spinal disc device is deformable to conform to an interior region of a vertebral disc.

41. The spinal disc device as recited in claim 34, wherein said spinal disc device is adapted to inject a volume of biocompatible material into said inner chamber of said expansile loop until a desired disc height is achieved.

42. The spinal disc device as recited in claim 34, wherein said spinal disc device is adapted to inject an volume of biocompatible material into said inner chamber of said expansile loop until a desired disc pressure is achieved.

43. An spinal disc device comprising:

a flexible and expandable expansile loop, said expansile loop having an interior section in slidable cooperation with an outer section, said expansile loop further having an interior chamber;

said outer section of said expansile loop having a inside surface and an outer opening;

said interior section of said expansile loop having an outside surface and a distal end;

a first flexible control element, said control element having a distal end, a distal section, and a proximal section, said distal end of said control element attached to said distal end of said interior section of said expansile loop, said control element

looping around said inside surface of said outer section of said expansile loop whereby said distal section of said control element is located within said interior chamber and said proximal section of said control element exits said expansile loop at said outer opening; and

a second flexible control element, said control element having a distal end, said distal end of said control element attached to said distal end of said interior section of said expansile loop.

44. The spinal disc device as recited in claim 43, further comprising an outer sheath, said outer sheath having an inner lumen.

45. The spinal disc device as recited in claim 44, whereby said spinal disc device is contained within said inner lumen of said outer sheath when said spinal disc device is in a contracted delivery configuration.

46. The spinal disc device as recited in claim 43, wherein said expansile loop is composed of braided material in a tubular form.

47. The spinal disc device as recited in claim 43, wherein said expansile loop is composed from a polymeric material.

48. The spinal disc device as recited in claim 43, wherein said expansile loop is composed from a metallic material.

49. The spinal disc device as recited in claim 43, wherein said control elements are composed from a polymeric material.

50. The spinal disc device as recited in claim 43, wherein said control elements are composed from a metallic material.

51. The spinal disc device as recited in claim 45, wherein said spinal disc device attains an expanded configuration when expelled from said outer sheath.

52. The spinal disc device as recited in claim 43, wherein said expansile loop forms a substantially circular shape when said interior section coaxially engages said outer section.

53. The spinal disc device as recited in claim 43, further comprising an inner chamber which is substantially continuous around said substantially circular shape.

54. The spinal disc device as recited in claim 43, further comprising the function to deliver within said inner chamber a biocompatible material to the inter-vertebral space.

55. The spinal disc device as recited in claim 52, wherein said inner chamber is filled with a polymeric material.

56. The spinal disc device as recited in claim 54, wherein one or more of said biocompatible materials is formed of a material selected from the group consisting of hydrophilic

polymers, hydrogels, homopolymer hydrogels, copolymer hydrogels, multi-polymer hydrogels, or interpenetrating hydrogels, acrylonitrile, acrylic acid, acrylimide, acrylimidine, including but not limited to PVA, PVP, PHEMA, PNVP, polyacrylamides, poly(ethylene oxide), polyvinyl alcohol, polyacrylonitrile, and polyvinyl pyrrolidone, silicone, polyurethanes, polycarbonate-polyurethane (e.g., Corethane) other biocompatible polymers, or combinations thereof.

57. The spinal disc device as recited in claim 54, wherein one or more of said biocompatible materials is formed of a material that is allowed to expand through the adsorption of liquids such as water selected from the group consisting of polyacrylamide, polyacrylonitrile, polyvinyl alcohol or other biocompatible hydrogels, solid fibrous collagen or other suitable hydrophilic biocompatible material or combinations thereof.

58. The spinal disc device as recited in claim 54, wherein one or more biocompatible materials is formed of a material selected from the group consisting of steroids, antibiotics, tissue necrosis factor alpha or its antagonists, analgesics, growth factors, genes or gene vectors in solution; biologic materials (hyaluronic acid, non-crosslinked collagen, fibrin, liquid fat or oils); synthetic polymers (polyethylene glycol, liquid silicones, synthetic oils), saline or combinations thereof.

59. The spinal disc device as recited in claim 54, wherein one or more biocompatible materials is formed of a material selected from the group consisting of bone graft materials

such as any described "bone cements" or any polymeric bone graft compounds, bone graft materials, nylon fibers, carbon fibers, glass fibers, collagen fibers, ceramic fibers, polyethylene fibers, poly(ethylene terephthalate), polyglycolides, polylactides, and combinations thereof.

60. The spinal disc device as recited in claim 43, wherein said spinal disc device is adapted to promote spinal fixation between two adjacent vertebral bodies.

61. The spinal disc device as recited in claim 43, wherein said spinal disc device is deformable to conform to an interior region of a vertebral disc.

62. The spinal disc device as recited in claim 54, wherein said spinal disc device is adapted to inject a volume of biocompatible material into said inner chamber of said expansile loop until a desired disc height is achieved.

63. The spinal disc device as recited in claim 54, wherein said spinal disc device is adapted to inject an volume of biocompatible material into said inner chamber of said expansile loop until a desired disc pressure is achieved.

64. An spinal disc device comprising:

a flexible and expandable expansile loop, said expansile loop having an interior section in slidable cooperation with an outer section, said expansile loop further having an interior chamber;

said outer section of said expansile loop having a inside surface and an outer opening;

said interior section of said expansile loop having an outside surface and a distal end;

said outer section having a portion invaginated within itself; and

a flexible control element, said control element having a distal end, said distal end of said control element attached to said distal end of said interior section of said expansile loop.

65. The spinal disc device as recited in claim 64, further comprising an outer sheath, said outer sheath having an inner lumen.

66. The spinal disc device as recited in claim 65, whereby said spinal disc device is contained within said inner lumen of said outer sheath when said spinal disc device is in a contracted delivery configuration.

67. The spinal disc device as recited in claim 64, wherein said expansile loop is composed of braided material in a tubular form.

68. The spinal disc device as recited in claim 64, wherein said expansile loop is composed from a polymeric material.

69. The spinal disc device as recited in claim 64, wherein said expansile loop is composed from a metallic material.

70. The spinal disc device as recited in claim 64, wherein said control elements are composed from a polymeric material.

71. The spinal disc device as recited in claim 64, wherein said control elements are composed from a metallic material.

72. The spinal disc device as recited in claim 66, wherein said spinal disc device attains an expanded configuration when expelled from said outer sheath.

73. The spinal disc device as recited in claim 64 wherein said expansile loop forms a substantially circular shape when said interior section coaxially engages said outer section.

74. The spinal disc device as recited in claim 64, further comprising an inner chamber which is substantially continuous around said substantially circular shape.

75. The spinal disc device as recited in claim 64, further comprising the function to deliver within said inner chamber a biocompatible material to the inter-vertebral space.

76. The spinal disc device as recited in claim 74, wherein said inner chamber is filled with a polymeric material.

77. The spinal disc device as recited in claim 75, wherein one or more of said biocompatible materials is formed of a

material selected from the group consisting of hydrophilic polymers, hydrogels, homopolymer hydrogels, copolymer hydrogels, multi-polymer hydrogels, or interpenetrating hydrogels, acrylonitrile, acrylic acid, acrylimide, acrylimidine, including but not limited to PVA, PVP, PHEMA, PNVP, polyacrylamides, poly(ethylene oxide), polyvinyl alcohol, polyarylonitrile, and polyvinyl pyrrolidone, silicone, polyurethanes, polycarbonate-polyurethane (e.g., Corethane) other biocompatible polymers, or combinations thereof.

78. The spinal disc device as recited in claim 75, wherein one or more of said biocompatible materials is formed of a material that is allowed to expand through the adsorption of liquids such as water selected from the group consisting of polyacrylamide, polyacrylonitrile, polyvinyl alcohol or other biocompatible hydrogels, solid fibrous collagen or other suitable hydrophilic biocompatible material or combinations thereof.

79. The spinal disc device as recited in claim 75, wherein one or more biocompatible materials is formed of a material selected from the group consisting of steroids, antibiotics, tissue necrosis factor alpha or its antagonists, analgesics, growth factors, genes or gene vectors in solution; biologic materials (hyaluronic acid, non-crosslinked collagen, fibrin, liquid fat or oils); synthetic polymers (polyethylene glycol, liquid silicones, synthetic oils), saline or combinations thereof.

80. The spinal disc device as recited in claim 75, wherein one or more biocompatible materials is formed of a material

selected from the group consisting of bone graft materials such as any described "bone cements" or any polymeric bone graft compounds, bone graft materials, nylon fibers, carbon fibers, glass fibers, collagen fibers, ceramic fibers, polyethylene fibers, poly(ethylene terephthalate), polyglycolides, polylactides, and combinations thereof.

81. The spinal disc device as recited in claim 64, wherein said spinal disc device is adapted to promote spinal fixation between two adjacent vertebral bodies.

82. The spinal disc device as recited in claim 64, wherein said spinal disc device is deformable to conform to an interior region of a vertebral disc.

83. The spinal disc device as recited in claim 75, wherein said spinal disc device is adapted to inject a volume of biocompatible material into said inner chamber of said expansile loop until a desired disc height is achieved.

84. The spinal disc device as recited in claim 75, wherein said spinal disc device is adapted to inject an volume of biocompatible material into said inner chamber of said expansile loop until a desired disc pressure is achieved.

85. A method for treating an inter-vertebral disc in a patient's spine, the disc having an annulus and a nucleus, the method comprising:

inserting an artificial disc replacement device into the inter-vertebral space to repair or reinforce a damaged annulus fiborosis;

positioning an mechanically expansile loop circumferentially around said annular tissues such that said expansile loop substantially encircles the inside of the annular space;

said mechanically expansile loop not requiring pressurization or injection of material to expand circumferentially or diametrically to fill the inter-vertebral space; and

expanding said mechanically expansile loop within said annular space to reinforce said annulus fibrosis.

86. The method of claim 85 including the step of subsequently delivering and injecting a suitable biomaterial to replace at least a portion of said damaged annular tissue.

87. A method for treating an inter-vertebral disc in a patient's spine, the disc having an annulus and a nucleus, the method comprising:

inserting an artificial disc replacement device to repair or replace damaged or extracted nucleus tissue;

positioning a mechanically expansile loop in the inter-vertebral space such that said mechanically expansile loop substantially encircles the nucleus space;

said mechanically expansile loop having an inner chamber;

mechanically expanding the expansile loop within said nucleus space to the limits of the remaining annulus, prior to injecting any biomaterial into said inner chamber; and

delivering and injecting a suitable biomaterial into said inner chamber in order to replace at least a portion of removed or damaged nucleus tissue.

88. A method for treating an inter-vertebral disc in a patient's spine, the disc having an annulus and a nucleus, the method comprising:

inserting an artificial disc replacement device into the inter-vertebral space in order to reinforce or repair damaged annular tissue;

positioning a mechanically expansile loop around the inside of said annular tissues such that the expansile loop circumferentially encircles an annular space;

expanding the mechanically expansile loop within said vertebral space to the limits of the remaining annulus fibrosis without first pressurizing the expansile loop or first injecting material into said inner chamber;

inserting an artificial nucleus replacement device to an area of the damaged or removed nucleus pulposis;

positioning said expansile loop around said nucleus replacement such that the expansile loop substantially encircles said nucleus device; and

further mechanically expanding the expansile loop around said nucleus space and device.

89. A method for treating an inter-vertebral disc in a patient's spine, the disc having an annulus and a nucleus, the method comprising:

inserting an artificial disc replacement device into the inter-vertebral space in order to reinforce or repair damaged annular tissue;

positioning a mechanically expansile loop around the inside of said annular tissues such that the expansile loop circumferentially encircles an annular space;

expanding the mechanically expansile loop within said vertebral space to the limits of the remaining annulus fibrosus without first pressurizing the expansile loop or first injecting material into said inner chamber;

inserting or injecting an artificial nucleus replacement device to a the area of the damaged or removed nucleus pulposis;

positioning said expansile loop around said nucleus replacement such that the expansile loop substantially encircles said nucleus device;

further mechanically expanding the expansile loop around said nucleus space and device; and

delivering and injecting a suitable biomaterial to replace at least a portion of said nucleus tissue.

90. A method for treating an inter-vertebral disc in a patient's spine, the disc having an annulus and a nucleus, the method comprising:

Surgically removing at least a portion of the native nucleus between the adjacent vertebrae;

Said artificial disc replacement device comprising a mechanically expansile loop capable of expanding without pressurization or injection of material;

inserting an artificial disc replacement device within the inter-vertebral space between two adjacent vertebrae;

positioning said mechanically expansile loop within said inter-vertebral space;

mechanically expanding the expansile loop such that an outside surface expands to the limits of the inner portion of a native annulus;

expanding the expansile loop such that an inside surface expands to the limits of the area previously occupied by the native nucleus; and

delivering and injecting a suitable biomaterial to facilitate the fusion of said two adjacent vertebrae.

91. A method for treating an inter-vertebral disc in a patient's spine, the disc having an annulus and a nucleus, the method comprising:

Surgically removing at least a portion of the native nucleus between the adjacent vertebrae;

inserting an artificial disc replacement device within the inter-vertebral space between two adjacent vertebrae, said artificial disc replacement device comprising a mechanically expansile loop capable of expanding without pressurization or injection of material, said artificial disc replacement device having a central area, said artificial disc replacement device enclosing an nucleus replacement material within said central area, said nucleus replacement material having a central waist and two terminal areas;

positioning said mechanically expansile loop within said inter-vertebral space;

diametrically expanding the expansile loop such that an outside surface expands to the limits of the inner portion of a native annulus;

expanding the expansile loop such that the control element disproportionately contracts said nuclear

replacement material whereby said control element constricts said central waist more than said terminal ends.

92. The method as recited in claim 91, wherein said nuclear replacement materials is formed of a material selected from the group consisting of hydrophilic polymers, hydrogels, homopolymer hydrogels, copolymer hydrogels, multi-polymer hydrogels, or interpenetrating hydrogels, acrylonitrile, acrylic acid, acrylimide, acrylimidine, including but not limited to PVA, PVP, PHEMA, PNVP, polyacrylamides, poly(ethylene oxide), polyvinyl alcohol, polyarylonitrile, and polyvinyl pyrrolidone, silicone, polyurethanes, polycarbonate-polyurethane (e.g., Corethane) other biocompatible polymers, or combinations thereof.

93. A method for treating an inter-vertebral disc in a patient's spine, the method comprising:

inserting an artificial disc replacement device within the inter-vertebral space said artificial disc replacement device having a central area, said artificial disc replacement device enclosing an nucleus replacement material within said central area, said nucleus replacement material having a centrally located waist and two terminal end areas;

positioning said mechanically expansile loop within said inter-vertebral space;

diametrically expanding the expansile loop with a control element such that an outside surface of the

expansile loop expands to the limits of the inner portion of a native annulus, whereby said expanding disproportionately contracts said nuclear replacement material such that said expansile loop constricts said centrally located waist more than said terminal ends.

94. The method as recited in claim 93, wherein said nuclear replacement materials is formed of a material selected from the group consisting of hydrophilic polymers, hydrogels, homopolymer hydrogels, copolymer hydrogels, multi-polymer hydrogels, or interpenetrating hydrogels, acrylonitrile, acrylic acid, acrylimide, acrylimidine, including but not limited to PVA, PVP, PHEMA, PNVP, polyacrylamides, poly(ethylene oxide), polyvinyl alcohol, polyarylonitrile, and polyvinyl pyrrolidone, silicone, polyurethanes, polycarbonate-polyurethane (e.g., Corethane) other biocompatible polymers, or combinations thereof.

95. A method for treating an inter-vertebral disc in a patient's spine, the method comprising:

inserting an artificial disc replacement device within the inter-vertebral space, said artificial disc replacement device having a central area;

positioning said mechanically expansile loop within said inter-vertebral space;

expanding the expansile loop with a control element to a first configuration such that an outside surface of

the expansile loop expands to the limits of the inner portion of a native annulus;

injecting said nucleus replacement within said central lumen, said nucleus replacement material having a centrally located waist and two terminal end areas;

expanding the expansile loop to a second configuration whereby said expanding disproportionately contracts said nuclear replacement material such that said expansile loop constricts said centrally located waist more than said terminal ends.

96. The method as recited in claim 95, wherein said nuclear replacement materials is formed of a material selected from the group consisting of hydrophilic polymers, hydrogels, homopolymer hydrogels, copolymer hydrogels, multi-polymer hydrogels, or interpenetrating hydrogels, acrylonitrile, acrylic acid, acrylimide, acrylimidine, including but not limited to PVA, PVP, PHEMA, PNVP, polyacrylamides, poly(ethylene oxide), polyvinyl alcohol, polyarylonitrile, and polyvinyl pyrrolidone, silicone, polyurethanes, polycarbonate-polyurethane (e.g., Corethane) other biocompatible polymers, or combinations thereof.

97. A spinal disc device comprising:

a flexible and expandable expansile loop, said expansile loop having an interior section in slidable cooperation with an outer section, said expansile loop further having an interior chamber;

said outer section of said expansile loop having a
inside surface and an outer opening;

said interior section of said expansile loop having an
outside surface, and inside surface, and a distal end;

a central area located within said inside surface of
said interior section, said central area having a
centrally located waist and two terminal areas; and

means for contracting said central area whereby said
means disproportionately contracts said central area
whereby said centrally located waist results is a
smaller diameter than the diameter of said terminal
areas.

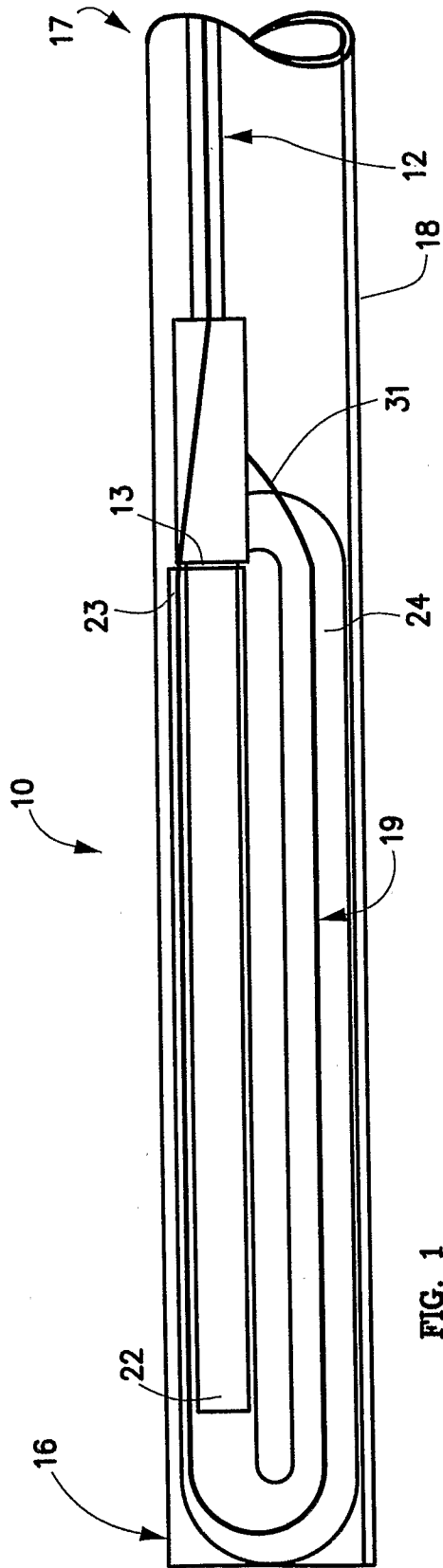

FIG. 1

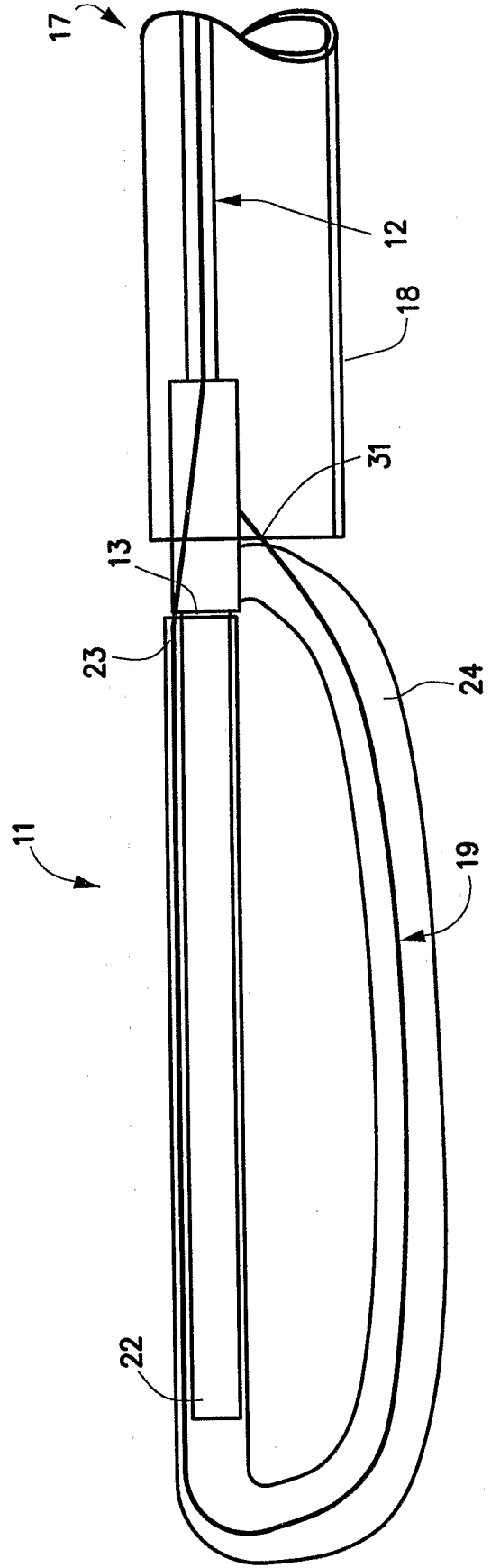

FIG. 2

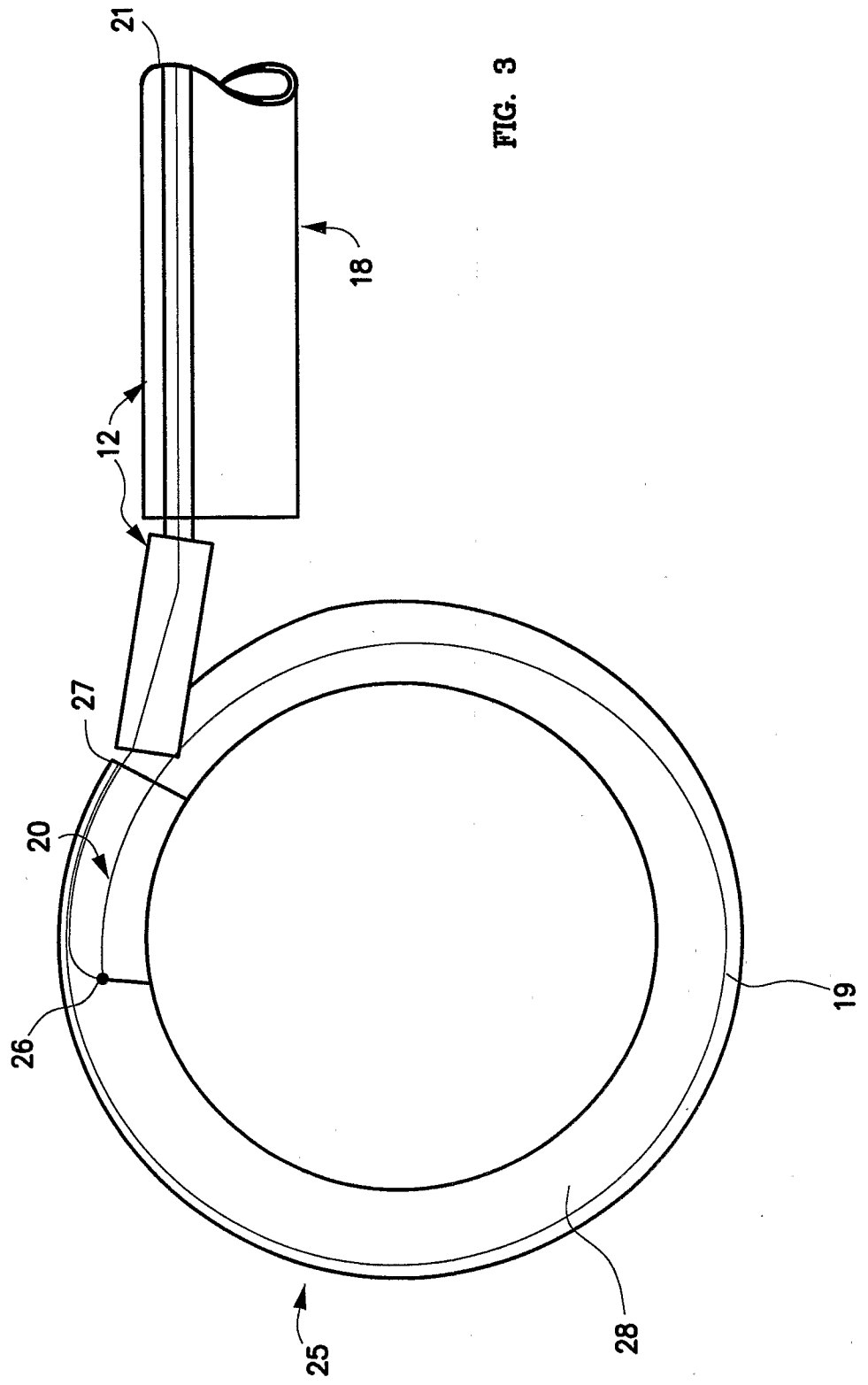

FIG. 3

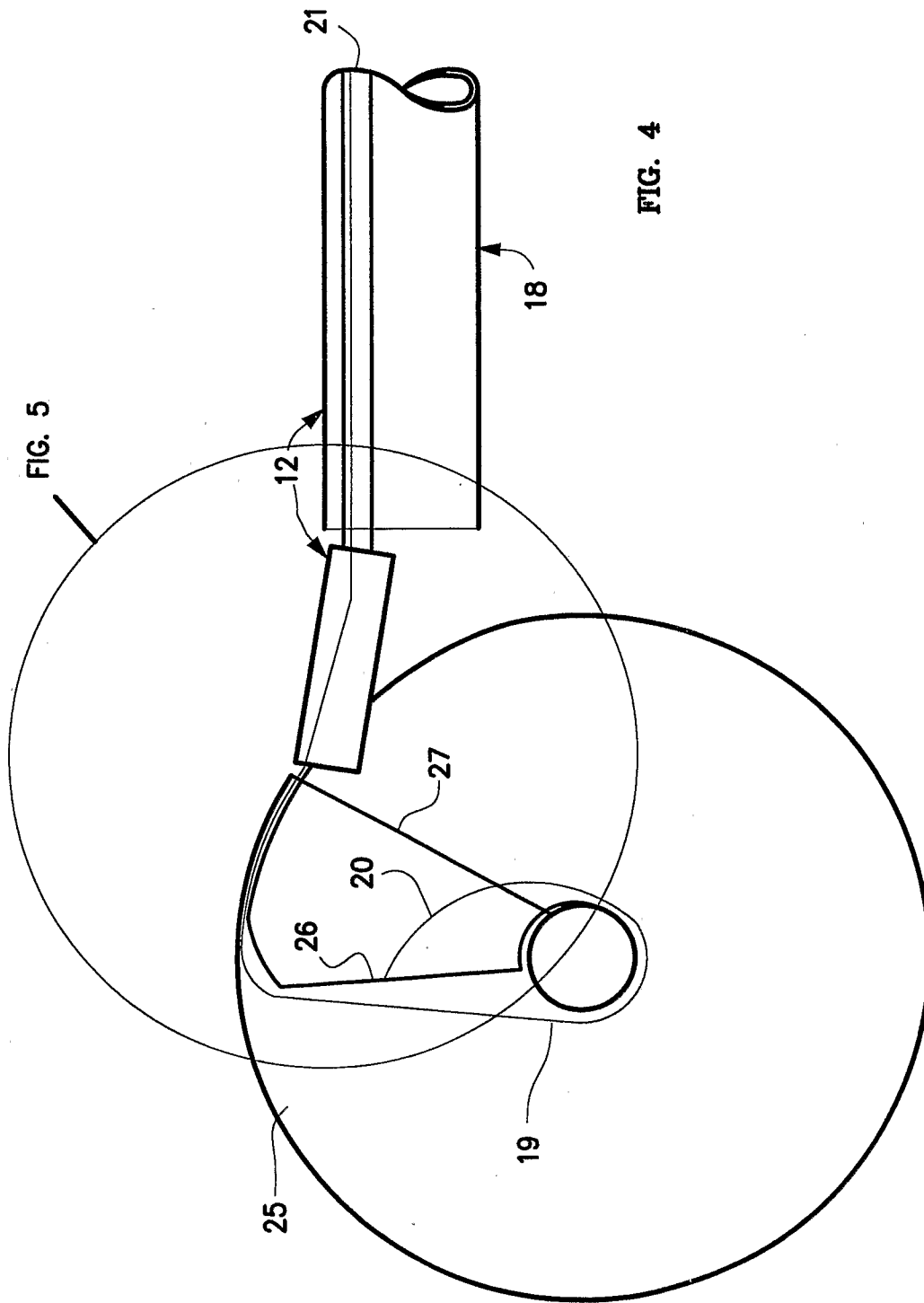

FIG. 4

FIG. 5

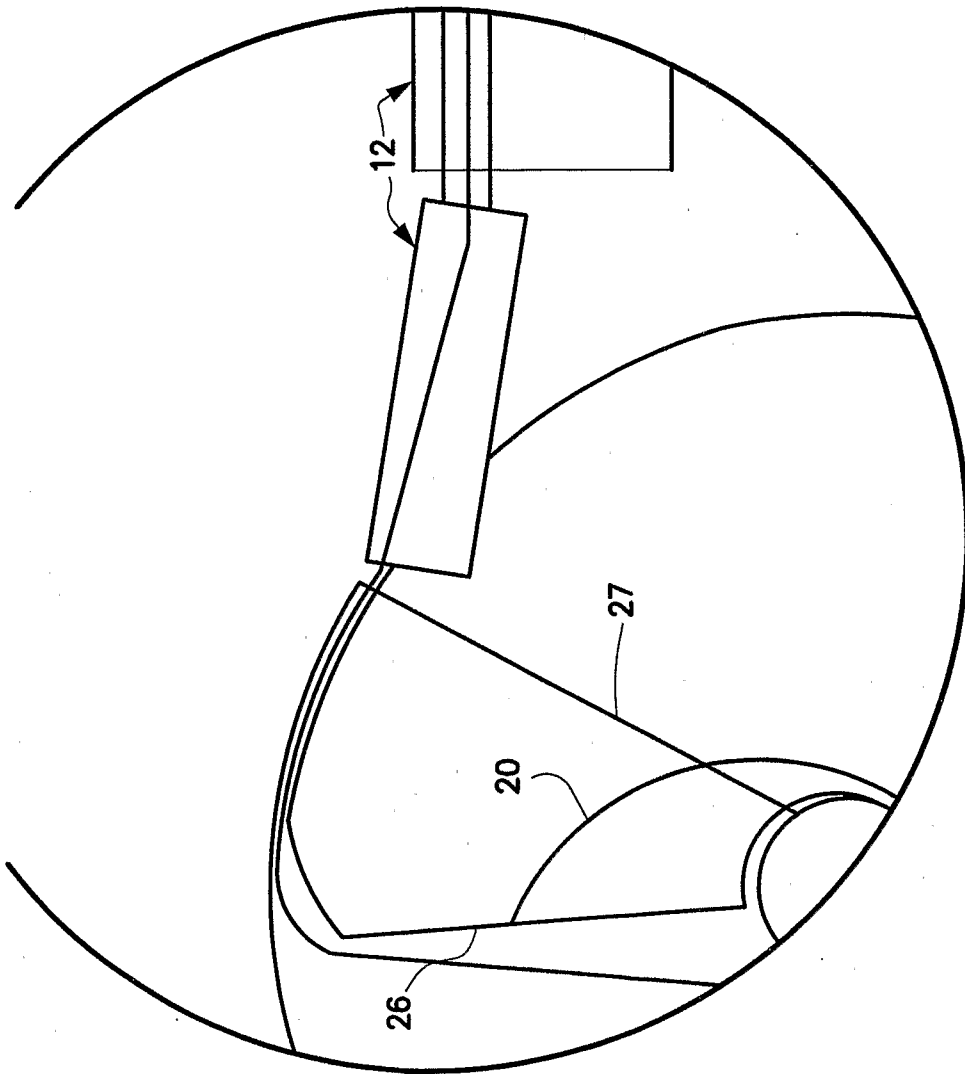

FIG. 5

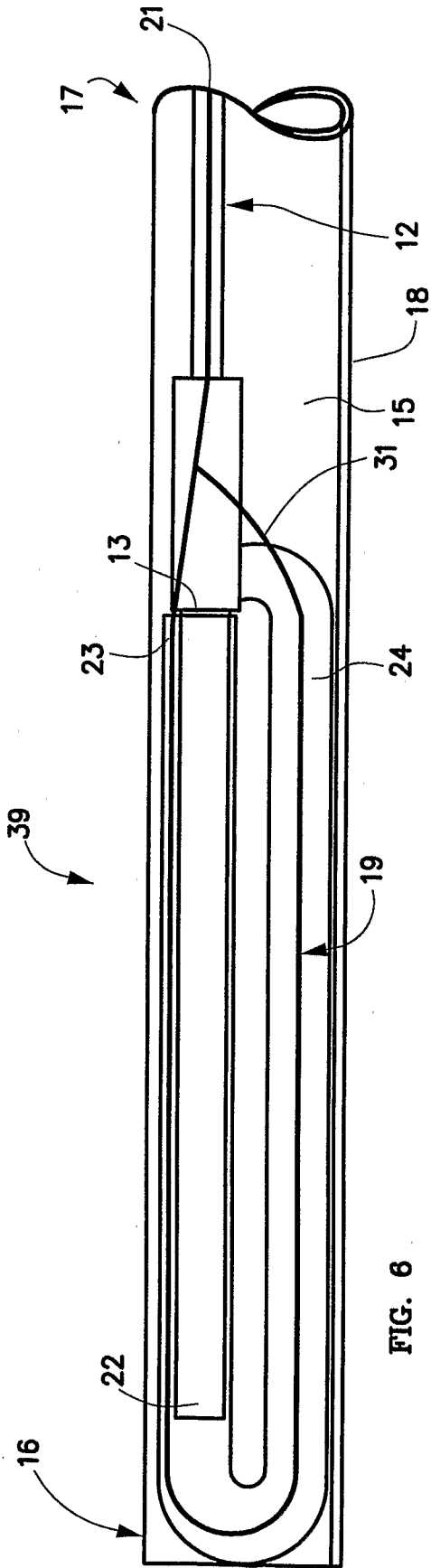

FIG. 6

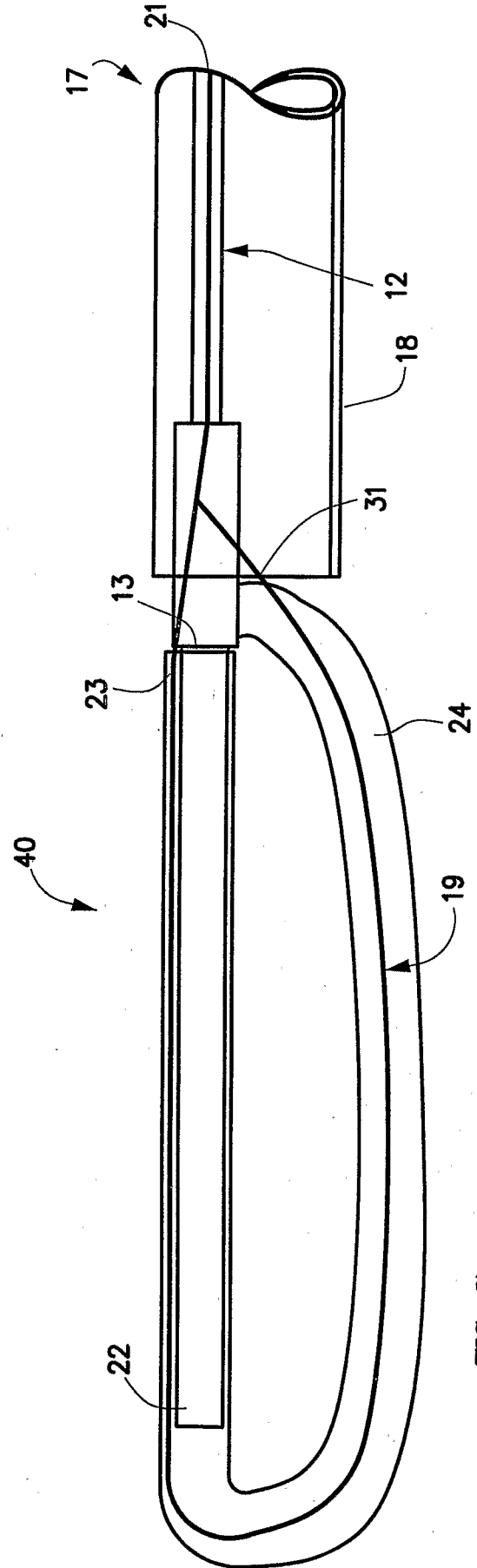

FIG. 7

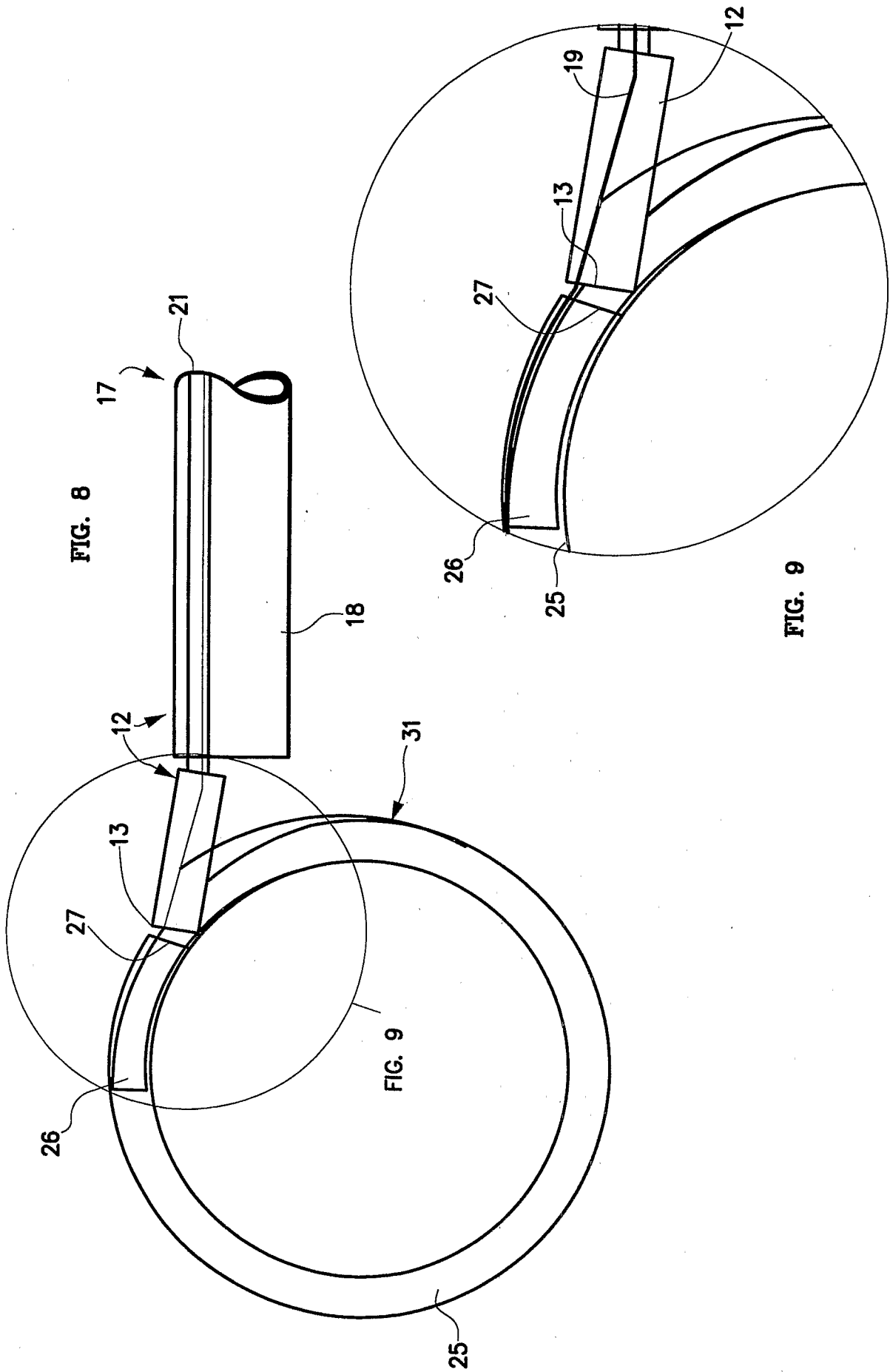
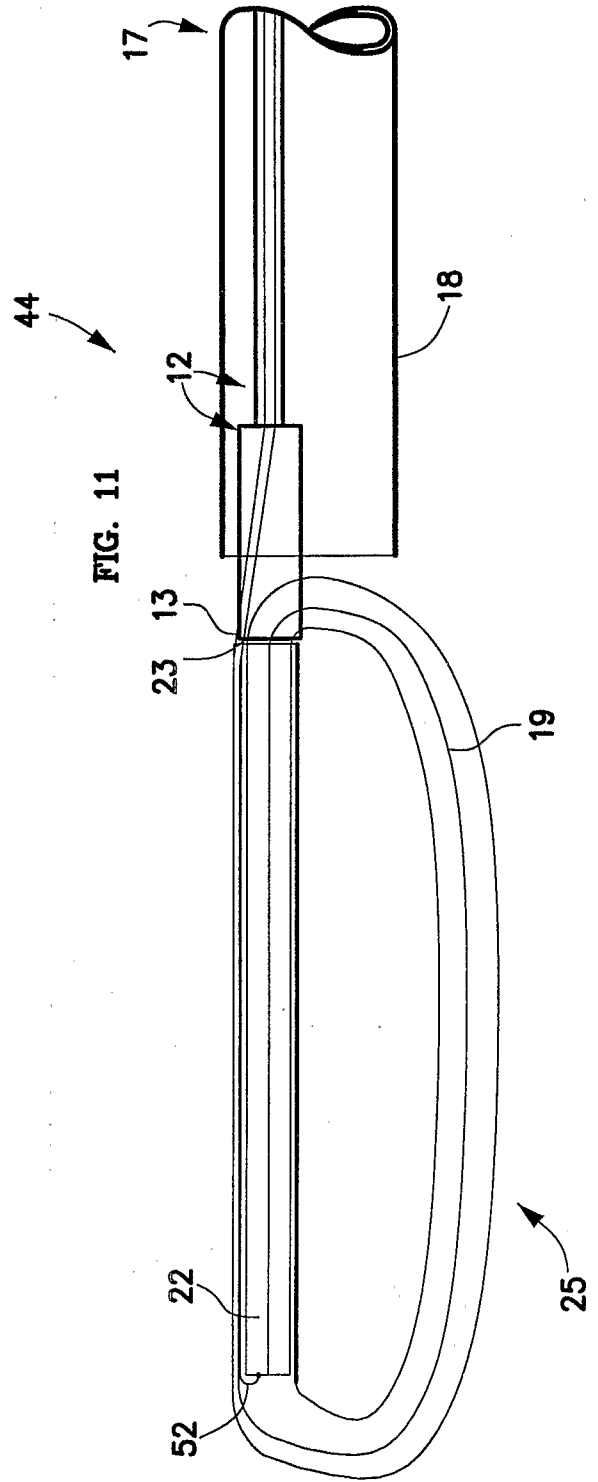
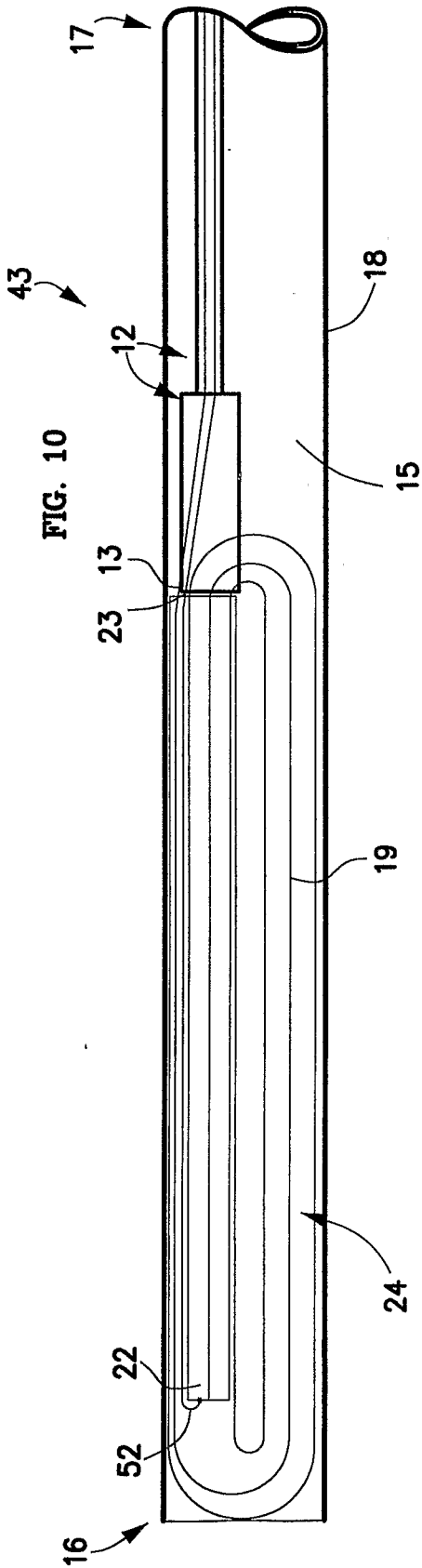

FIG. 8

FIG. 9



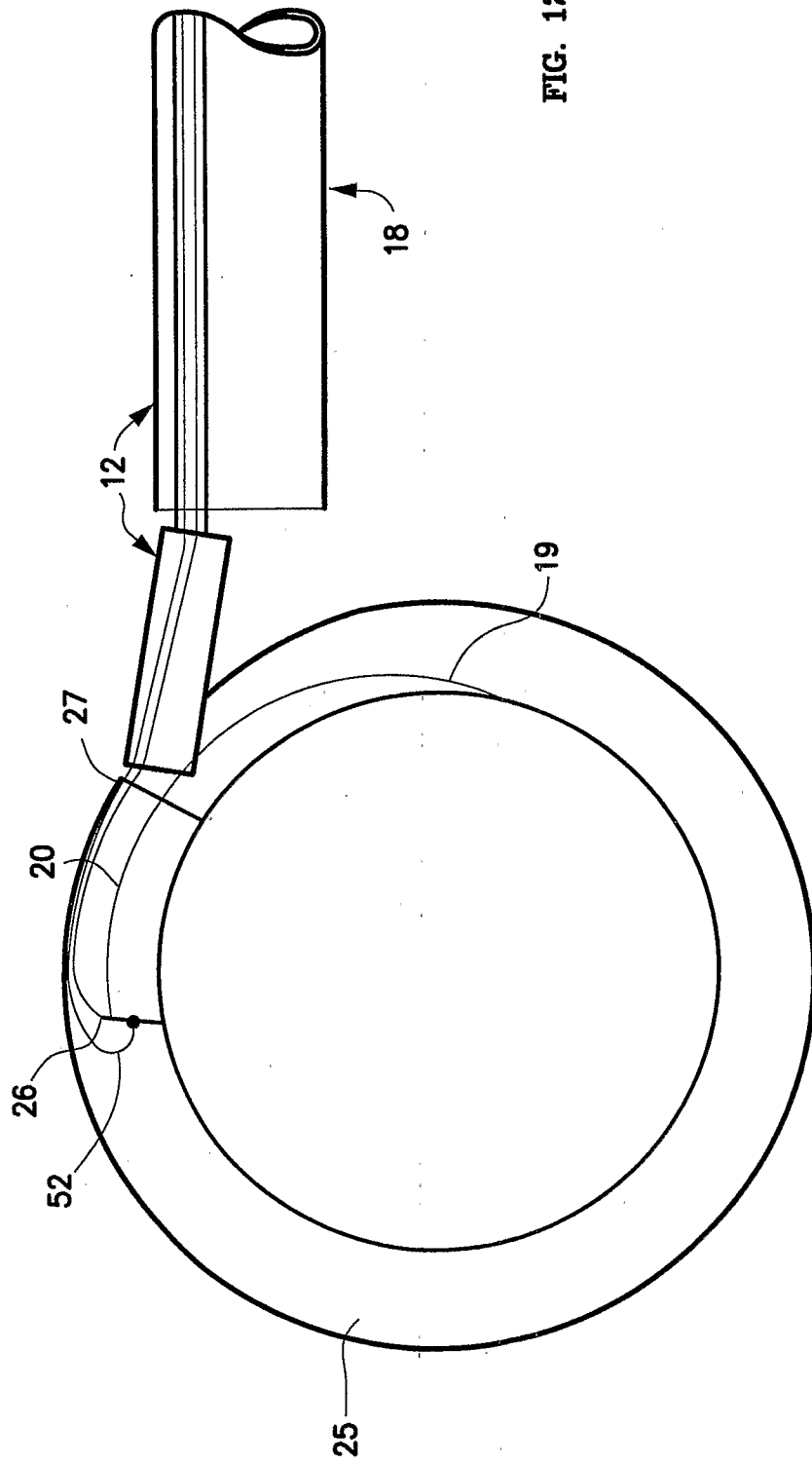
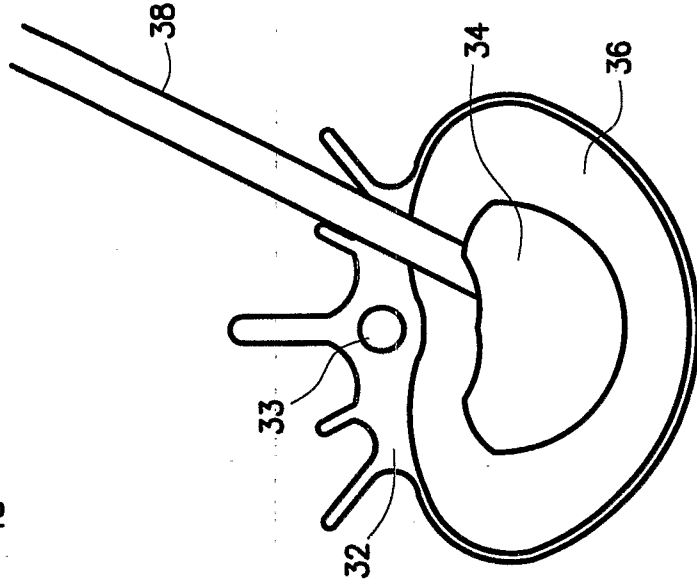
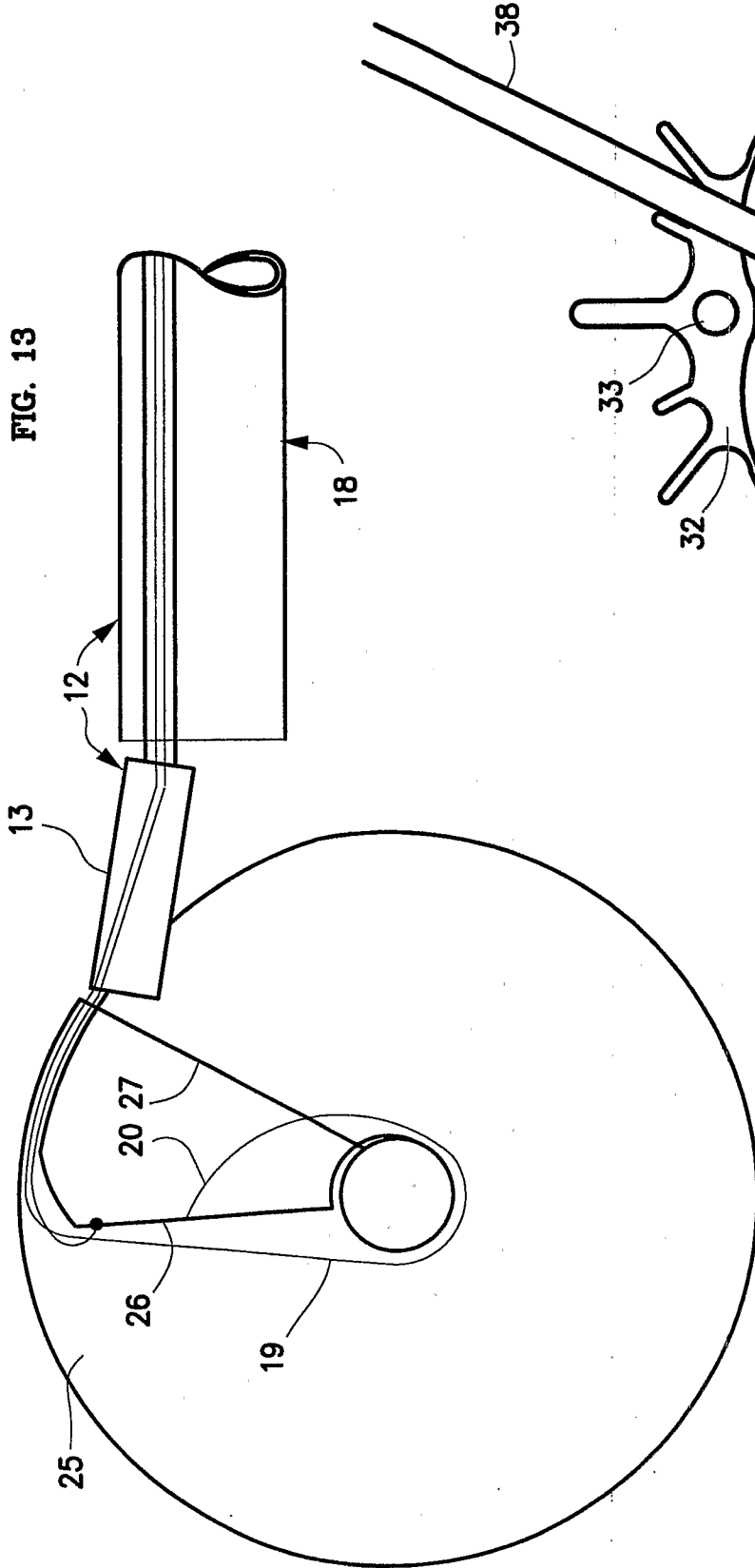

FIG. 12



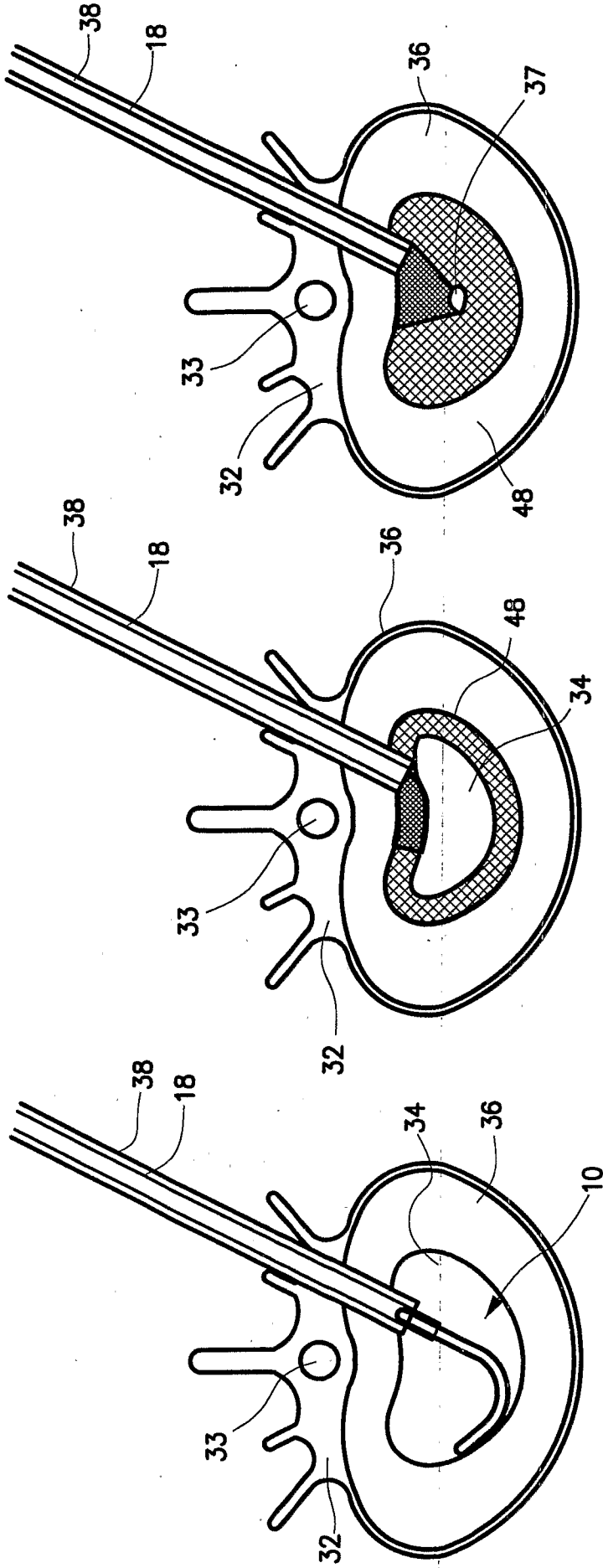
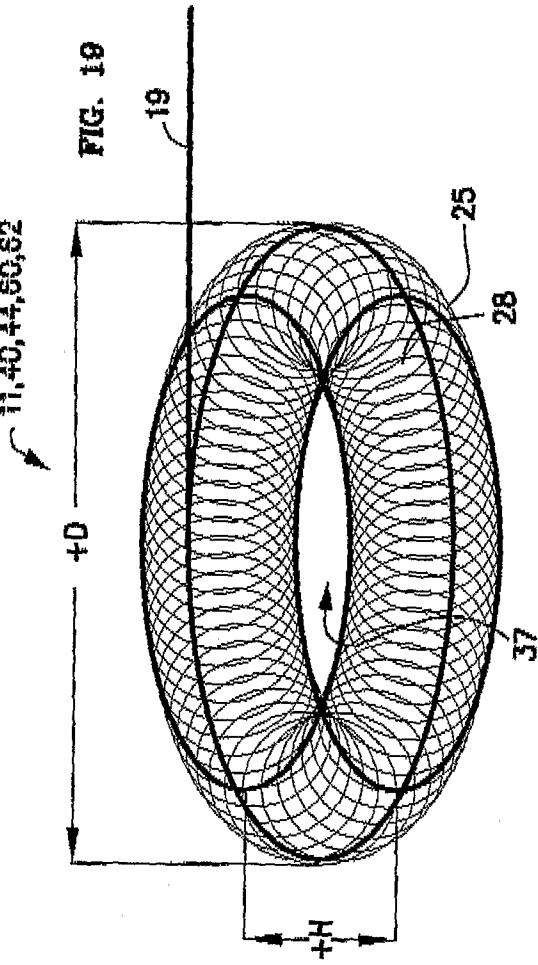

FIG. 17

FIG. 16

FIG. 15



11, 40, 44, 50, 52

FIG. 19

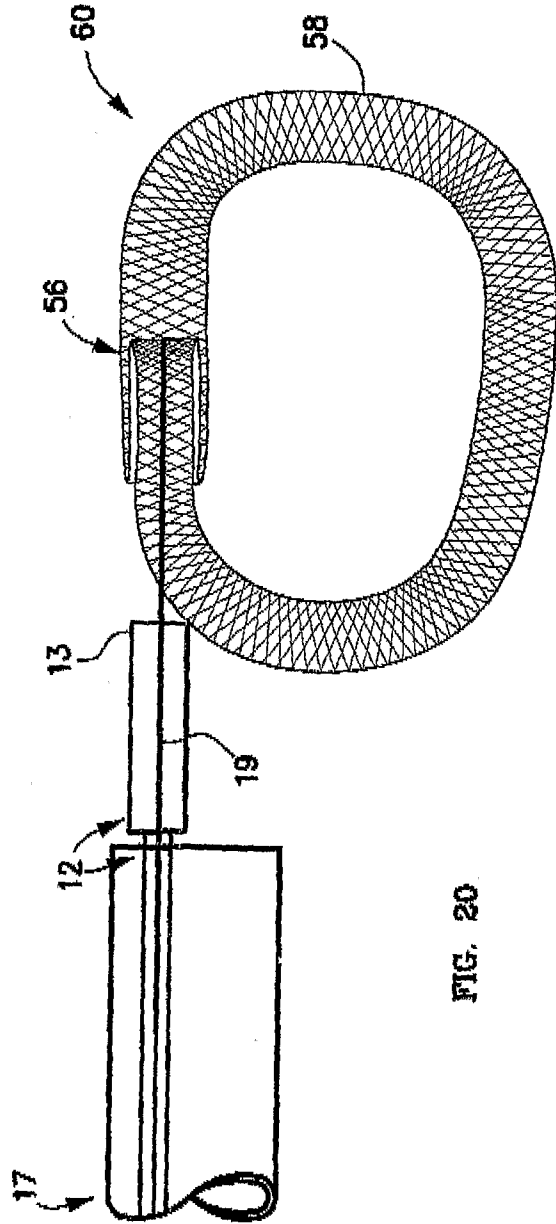
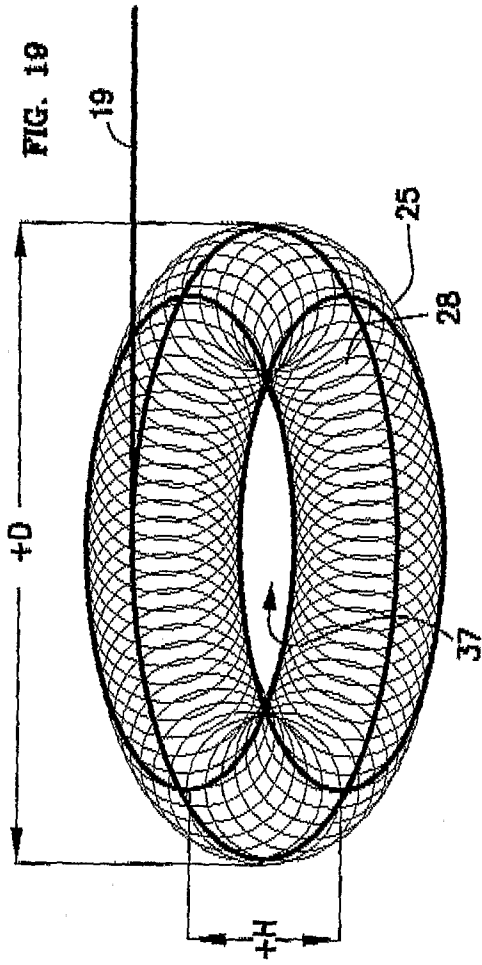

FIG. 20

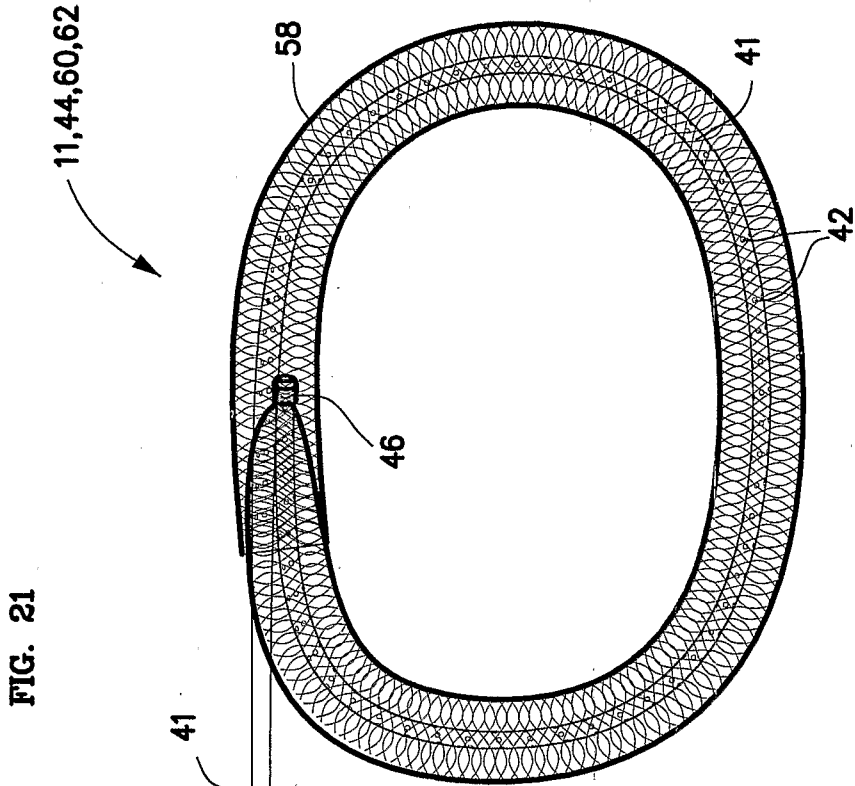

FIG. 21

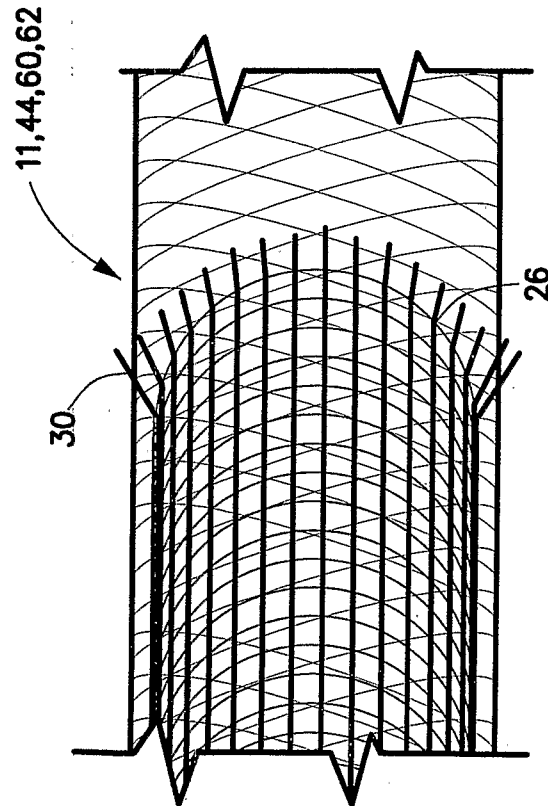
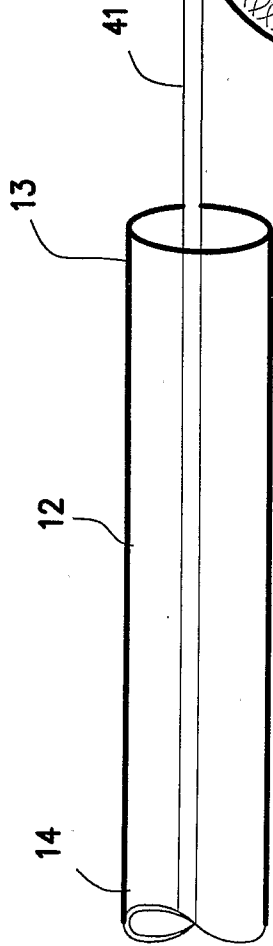
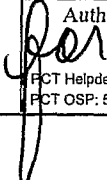

FIG. 22

INTERNATIONAL SEARCH REPORT

International application No.

PCT/US 06/27608

<p>A. CLASSIFICATION OF SUBJECT MATTER IPC(8): A61F 2/44 (2007.01) USPC: 623/17.16 According to International Patent Classification (IPC) or to both national classification and IPC</p>		
<p>B. FIELDS SEARCHED</p>		
<p>Minimum documentation searched (classification system followed by classification symbols) USPC: 623/17.11, 17.16</p>		
<p>Documentation searched other than minimum documentation to the extent that such documents are included in the fields searched GOOGLE SCHOLAR SEARCH SEARCH TERMS/PHRASES: artificial, disc, replacement, "flexible control", element, expansile, loop, inserting, intervertebral, sheath</p>		
<p>Electronic data base consulted during the international search (name of data base and, where practicable, search terms used) USPTO WEST [USPT]. SEARCH TERMS/PHRASES: spinal disc, flexible, expandable, expansile loop, control element, lumen, sheath, braided material, metallic material, polymeric material, chamber, saline, polyvinyl, bone graft, bone cements, spinal fixation, slidable, telescoping, encircles, remove, nucleus, pressurization</p>		
<p>C. DOCUMENTS CONSIDERED TO BE RELEVANT</p>		
Category*	Citation of document, with indication, where appropriate, of the relevant passages	Relevant to claim No.
A	US 6,712,853 B2 (Kuslich) 30 March 2004 (30.03.2004), Column 8, line 40; Column 9, lines 15-16; and Column 12, lines 12-14.	1,4,5,17,22,25,26,38,46,49,59,68,70 and 80
A	US 6,419,704 B1 (Ferree) 16 July 2002 (16.07.2002), Column 5, lines 42-43.	16,37,58, and 79
A	US 6,482,235 B1 (Lambrech, et al.) 19 November 2002 (19.11.2002), Figures 51A through 52B	1,4,5,17,22,25,26,38,46,49,59,68,70 and 80
<p><input type="checkbox"/> Further documents are listed in the continuation of Box C. <input type="checkbox"/></p>		
<p>* Special categories of cited documents:</p>		
"A"	document defining the general state of the art which is not considered to be of particular relevance	"T" later document published after the international filing date or priority date and not in conflict with the application but cited to understand the principle or theory underlying the invention
"E"	earlier application or patent but published on or after the international filing date	"X" document of particular relevance; the claimed invention cannot be considered novel or cannot be considered to involve an inventive step when the document is taken alone
"L"	document which may throw doubts on priority claim(s) or which is cited to establish the publication date of another citation or other special reason (as specified)	"Y" document of particular relevance; the claimed invention cannot be considered to involve an inventive step when the document is combined with one or more other such documents, such combination being obvious to a person skilled in the art
"O"	document referring to an oral disclosure, use, exhibition or other means	"&" document member of the same patent family
"P"	document published prior to the international filing date but later than the priority date claimed	
<p>Date of the actual completion of the international search 09 January 2007 (09.01.2007)</p>		<p>Date of mailing of the international search report 08 MAY 2007</p>
<p>Name and mailing address of the ISA/US Mail Stop PCT, Attn: ISA/US, Commissioner for Patents P.O. Box 1450, Alexandria, Virginia 22313-1450. Facsimile No. 571-273-3201</p>		<p>Authorized officer:  Lee W. Young PCT Helpdesk: 571-272-4300 PCT OSP: 571-272-7774</p>