

(19) **DANMARK**



Patent- og
Varemærkestyrelsen

(10) **DK/EP 1176280 T3**

(12) **Oversættelse af
europæisk patentskrift**

-
- (51) Int.Cl.: ***E 05 F 15/16 (2006.01)***
- (45) Oversættelsen bekendtgjort den: **2014-03-03**
- (80) Dato for Den Europæiske Patentmyndigheds bekendtgørelse om meddelelse af patentet: **2014-02-19**
- (86) Europæisk ansøgning nr.: **00116449.0**
- (86) Europæisk indleveringsdag: **2000-07-28**
- (87) Den europæiske ansøgnings publiceringsdag: **2002-01-30**
- (84) Designerede stater: **AT BE CH CY DE DK ES FI FR GB GR IE IT LI LU MC NL PT SE**
- (73) Patenthaver: **Novoferm GmbH, Isselburger Strasse 31, 46459 Rees, Tyskland**
Hörmann KG Brockhagen, Horststrasse 17, 33803 Steinhagen, Tyskland
- (74) Fuldmægtig i Danmark: **Zacco Denmark A/S, Hans Bekkevolds Allé 7, 2900 Hellerup, Danmark**
- (54) Benævnelse: **Port, især garageport**
- (56) Fremdragne publikationer:
EP-A- 0 222 300
EP-A- 0 230 999
EP-A- 0 523 630
DE-A- 19 808 696
US-A- 4 732 203

DESCRIPTION

The invention relates to an electric door drive for opening and closing a single- or multi-part door leaf, which is
5 guided in essentially horizontal runner rails during an opening and closing movement. The door leaf can for example be a multi-part door leaf of a sectional door or a single-part door leaf of a swivelling door.

10 Doors are known which comprise a multi-part door leaf or a sectional door leaf and in which the door drive is embodied in the form of a drive motor, which is fixedly connected to a panel of the sectional door leaf. During an opening and closing movement of the door leaf, this drive motor is
15 guided with a runner wheel in a rail (EP-A 0 222 204). These previously known garage doors are characterised by drawbacks. During an opening and closing movement, mechanical constraints often easily arise between the structural elements, which can hinder functionally reliable
20 opening or closing of the door leaf. Costly and complicated guides are required for a traversable drive motor.

There is known from EP 0 523 630 A1 an electric drive for sectional doors which is suitable for sliding doors
25 traversable around an arch and in a straight direction. The accompanying drive unit during an opening and closing movement of the door is mounted rotatably on a leaf of the door, so that it can follow track curvatures. The drive gear wheel of the motor engages in a toothed belt, which is
30 tensioned at a distance from a runner rail of the door and is supported in the arch by a bracket.

The problem underlying the invention is to provide an electric door drive for the opening or closing of a single-
35 or multi-part door leaf, wherein simple and low-cost guidance and support of a traversable drive motor is implemented and wherein a problem-free and functionally

reliable opening and closing movement of the door leaf is possible.

5 The subject-matter of the invention and the solution to this problem is an electric door drive with the features of claim 1 for the opening and closing of a single- or multi-part door leaf, which is guided in essentially horizontal runner rails during an opening and closing movement.

10 A flexible line element is provided on at least one runner rail. The door drive comprises a drive motor with a drive wheel, which is guided in the runner rail and around which the line element is partially wound. When a drive movement of the drive wheel takes place, the drive motor can be
15 traversed along the runner rail by means of a form-fit connection with the line element. The opening and closing movement of the door leaf is brought about by the traversing of the drive motor.

20 The line element is constituted such that the underside of the line element facing the runner rail interacts with the surface of the drive wheel by means of a form-fit connection. The line element is a toothed belt. The drive wheel is constituted as a sprocket or toothed wheel, so
25 that the drive motor can be be traversed along the runner rail when the sprocket rotates by means of the form-fit connection between the sprocket and the toothed belt. The tothing of the toothed belt is provided on the underside of the toothed belt facing the runner rail. The toothed
30 belt is pretensioned.

According to the invention, the drive motor comprises at least two guide rollers, wherein the drive wheel is disposed in the middle between the two guide rollers. A
35 very effective guidance and support of the drive motor on the runner rail is achieved with the aid of these guide

rollers. Moreover, the guide rollers support the form-fit connection between the drive wheel and the line element.

5 According to a preferred embodiment of the invention, at least one guide sliding element is provided on the drive motor for guidance of the drive motor on the runner rail, said guide sliding element comprising a side wall of the runner rail. According to a very preferred embodiment, two guide sliding elements disposed one behind the other in the longitudinal direction of the runner rail are provided. One guide sliding element is expediently provided beside a guide roller. Very effective support and guidance of the drive motor on the runner rail is also achieved with the aid of the guide sliding elements.

15 The drive motor is connected by a connection element to the upper quarter of the door leaf. The term "upper quarter" relates to the vertical height of the door leaf in the closed state of the door. The connection element is for example only one rigid connecting rod, which is connected respectively by a hinge joint to the drive motor and the door leaf. The drive motor acts on the door leaf via this connection element during the opening or closing movement.

25 The drive motor preferably comprises a self-locking gear unit for ensuring that the door leaf cannot be pushed out from the exterior.

30 The invention is based on the knowledge that a problem-free, easy and functionally reliable opening and closing movement of a door leaf is possible if the teaching according to claim 1 is implemented. This easy opening and closing movement is also achieved in a very straightforward and low-cost manner. On account of the special embodiment of the drive motor and the associated structural elements, it is possible for the drive motor to be guided and supported solely in a single runner rail. In contrast with

the measures known from the prior art, expensive guidance and support measures on the other structural components of the door are therefore not required. Moreover, the drive motor is traversed only horizontally during the opening and closing procedure. Vertical guidance sections for the drive motor are not present. This also assists a functionally reliable and fault-free opening and closing of the door. In the embodiment according to the invention, the drive motor can be connected to the upper region of the door leaf by preferably only a single connection element, e.g. a connecting rod. It is possible for the connection element or connecting rod to be constituted only relatively short. In turn, the effect of this is that the distance of the drive motor from the uppermost panel in the open state of the door is only very small. Compared to the known doors, the runner rail in which the drive motor is guided can advantageously be constituted shorter.

The invention is explained in greater detail below with the aid of a drawing merely representing an example of embodiment. In the figures, in diagrammatic representation:

Fig. 1 shows a longitudinal section through a sectional door with an electric door drive in the closed state,

Fig. 2 shows a detail from fig. 1 in a representation magnified compared to fig. 1, partially broken away,

Fig. 3 shows a cross-section A-A through the object according to fig. 2 and

Fig. 4 shows the object according to fig. 1 in the opened state.

The door represented in the figures is a garage door which is constituted as a sectional door with a multi-part door leaf 1. Door leaf 1 comprises panels 2, 3 connected in a hinged manner, which are guided with runner wheels 4, 5 in
5 runner rails 6, 7 disposed on both sides of door leaf 1. An electric door drive with a drive motor 8 is provided for the opening and closing of door leaf 1.

10 Runner wheel 4 of uppermost panel 2 is guided in an essentially horizontal upper runner rail 6, whilst runner wheels 5 of remaining panels 3 are guided in a lower runner rail 7, which is constituted as an arched rail. This arched rail comprises a vertical section 9 parallel to door frame
15 upper runner rail 6, the two sections 9, 10 being connected via an arch 11.

Especially in figures 2 and 3, it can be seen that there is provided on upper runner rail 6, or more precisely on
20 runner rail base 12, a flexible line element which runs along upper runner rail 6 and which can be raised from upper runner rail 6. In the example of embodiment, this line element is constituted as a toothed belt 13. According to the invention, drive motor 8 is guided solely in one
25 runner rail and, in the example of embodiment, in upper runner rail 6. For this purpose, drive motor 8 comprises a drive wheel which is constituted as a sprocket 14. Sprocket 14 is guided in upper runner rail 6 and is disposed beneath the line element, i.e. in the example of embodiment beneath
30 toothed belt 13. When a drive motion or rotation of the drive wheel or sprocket 14 takes place, drive motor 8 can be traversed along upper runner rail 6 in particular by means of the form-fit connection of sprocket 14 with the toothed underside of toothed belt 13, said underside facing
35 the runner rail. Toothed belt 13 is thus orientated with its toothed surface towards runner rail base 12. Especially in fig. 2, it can be seen that, when a movement of drive

motor 8 takes place along upper runner rail 6, toothed belt 13 is always raised from runner rail base 12 at the location of sprocket 14 and runs over sprocket 14. Moreover, two guide rollers 15 running on the line element
5 are also provided for the guidance of drive motor 8 in upper runner rail 6. These guide rollers 15 are disposed on both sides of sprocket 14 in the longitudinal direction of runner rail 6 and run over the untoothed smooth rear of toothed belt 13.

10

Preferably, and in the example of embodiment, two guide sliding elements 16 are provided on drive motor 8 for guidance of drive motor 8 on upper runner rail 6. According to fig. 2, these guide sliding elements 16 are located in
15 front of guide rollers 15, this having been indicated by a broken line in fig. 2. It can be seen in fig. 3 that a guide sliding element 16 preferably comprises on the inside and on the outside a side wall 17 of upper runner rail 6, said side wall proceeding from runner rail base 12.
20 Furthermore, fig. 3 shows that upper runner rail 6 is constituted as a hollow profile, which is open only on a longitudinal side. Sprocket 14 and guide rollers 15 engage in upper runner rail 6 at this longitudinal side.

25

It can be seen in figures 1, 2 and 4 that drive motor 8 is connected by only one connection element to door leaf 1. This connection element is a rigid connecting rod 18, which is linked by hinge joints 19, 20 on the one hand to door leaf 1 and on the other hand to drive motor 8. Connecting
30 rod 18 preferably does not comprise any further hinge joints. It can be seen in figures 1, 2 and 4 that connecting rod 18 can be constituted relatively short. This is possible on account of the functionally reliable drive according to the invention, without a problem-free opening and closing movement being adversely affected by the small
35 length of connecting rod 18. Fig. 4 shows that, on account of the small length of connecting rod 18, the distance of

drive motor 8 from uppermost panel 2 is also one relatively small, so that upper runner rail 6 can be constituted shorter compared to the corresponding runner rails known from the prior art. Expediently, and in the example of
5 embodiment, connecting rod 18 is connected in the upper (related to the height to door leaf 1 in the closed state) quarter of door leaf 1, i.e. is connected here to uppermost panel 2 of door leaf 1.

10 According to a very preferred embodiment, and in the example of embodiment, runner wheel 4 connected to uppermost panel 2 can be retracted into a vertical end section 21 of upper runner rail 6 during a closing movement of door leaf 1. During an opening movement of door leaf 1,
15 runner wheel 4 must therefore first surmount a short vertical section before it passes into the horizontal part of upper runner rail 6. With the aid of vertical end section 21, it is ensured, in combination with the self-locking gear unit of drive motor 8, that uppermost panel 2
20 is secured against unauthorised pushing-up from the exterior.

It can also be seen in fig. 2 that toothed belt 13 is fixed on the one hand at the front end and on the other hand at
25 the rear end of upper runner rail 6. One of the fixing points is expediently variable in respect of its position, so that toothed belt 13 can be put under desired pretensioning.

30 Especially in the case of wide doors, drive motors 8 are disposed in a traversable manner on runner rails 6 on both sides of the door leaf in the previously described manner and are connected in each case by a connection element 18 to one of upper panels 2, 3. The travel movements of the
35 drive motors can be synchronised electronically.

Patentkrav

1. Elektrisk portdrev til åbning og lukning af en portplade (1) i en eller flere dele, hvilken portplade ved en åbne- og lukkebevægelse er ført i løbeskinner (6), der i det væsentlige er horisontale, med
5 en drivmotor (8), som er forbundet med den øverste fjerdedel af portpladen (1) ved hjælp af et forbindelseselement (18), og en tandrem (13), som er tilvejebragt på løbeskinnebunden af en af de horisontale løbeskinner (6) og er sat under forspænding,
10 hvor drivmotoren (8) har et drivhjul (14), der er ført i løbeskinnen (6) og er delvist omslynget af tandremmen (13), samt føringsruller (15), der er anbragt på begge sider af drivhjulet, hvor føringsrullerne (15) løber hen over den ikke fortandede ryg af tandremmen (13), og hvor drivmotoren (8) ved en drivbevægelse af drivhjulet (14) kan køres langs med løbeskinnen (6) ved hjælp af en formluttende forbindelse med tandremmen (13).

2. Portdrev ifølge krav 1, **kendetegnet ved**, at tandremmen (13) ligger oven på løbeskinnens (6) løbeskinnebund (12).

20 3. Portplade ifølge krav 1 eller 2, **kendetegnet ved**, at der til føring af drivmotoren (14) er tilvejebragt mindst et føringsglideelement (16), som omfatter en sidevæg af løbeskinnen (6).

25 4. Portdrev ifølge et af kravene 1 til 3, **kendetegnet ved**, at der til føring af drivmotoren er tilvejebragt to føringsglideelementer (16), som hver især er anbragt efter hinanden i løbeskinnens (6) længderetning ved siden af en føringsrulle (15).

30 5. Portdrev ifølge et af kravene 1 til 4, **kendetegnet ved**, at forbindelseselementet (18) er udformet som en fast forbindelsesstang, som er forbundet med henholdsvis drivmotoren (8) og portpladen (1) via en ledforbindelse.

6. Portdrev ifølge et af kravene 1 til 5, **kendetegnet ved**, at drivmotoren (8) har et selvlåsende gear.

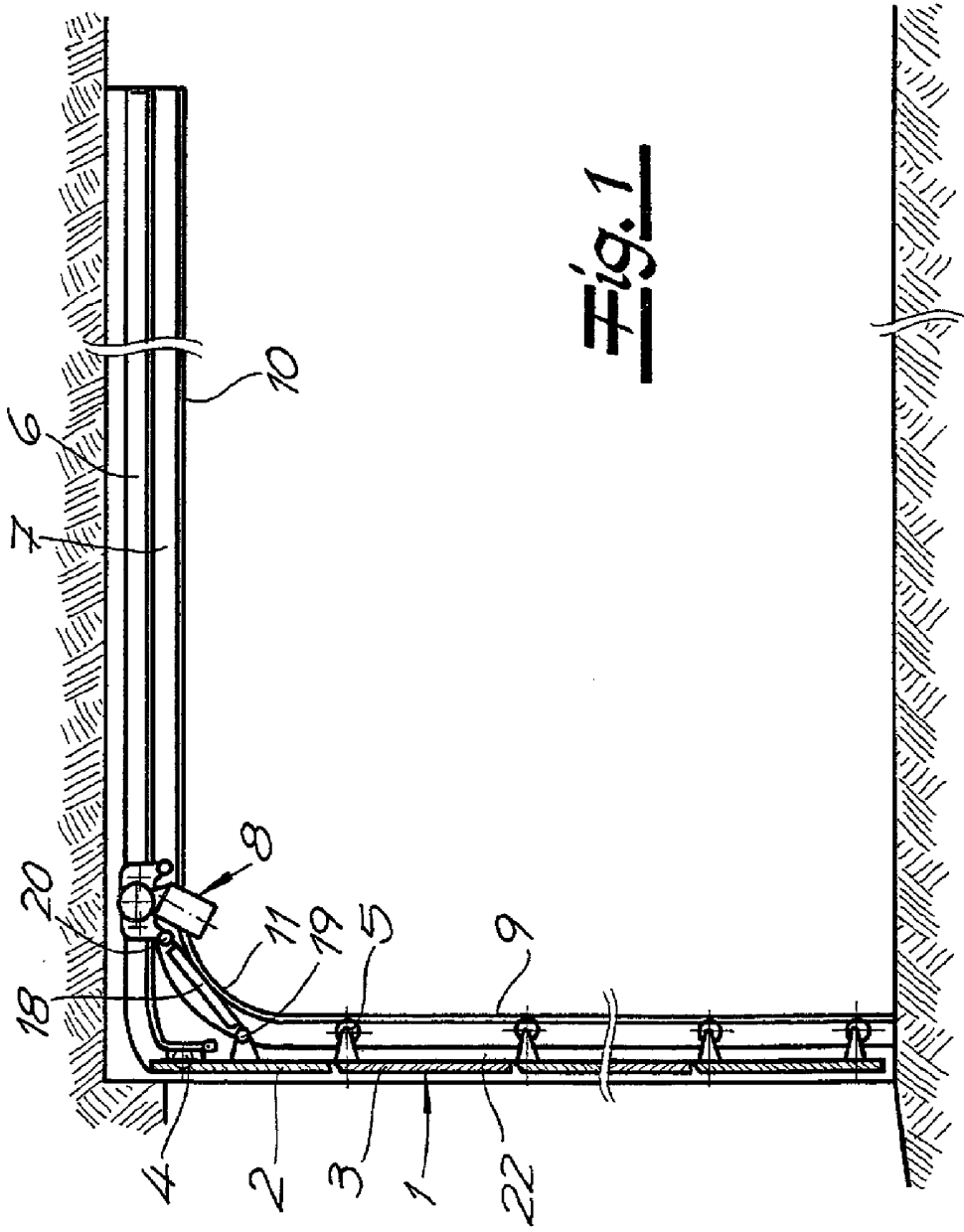

Fig. 1

Fig. 3

