

T. WALKER.

Quartz Mill.

No. 105,527.

Patented July 19, 1870.

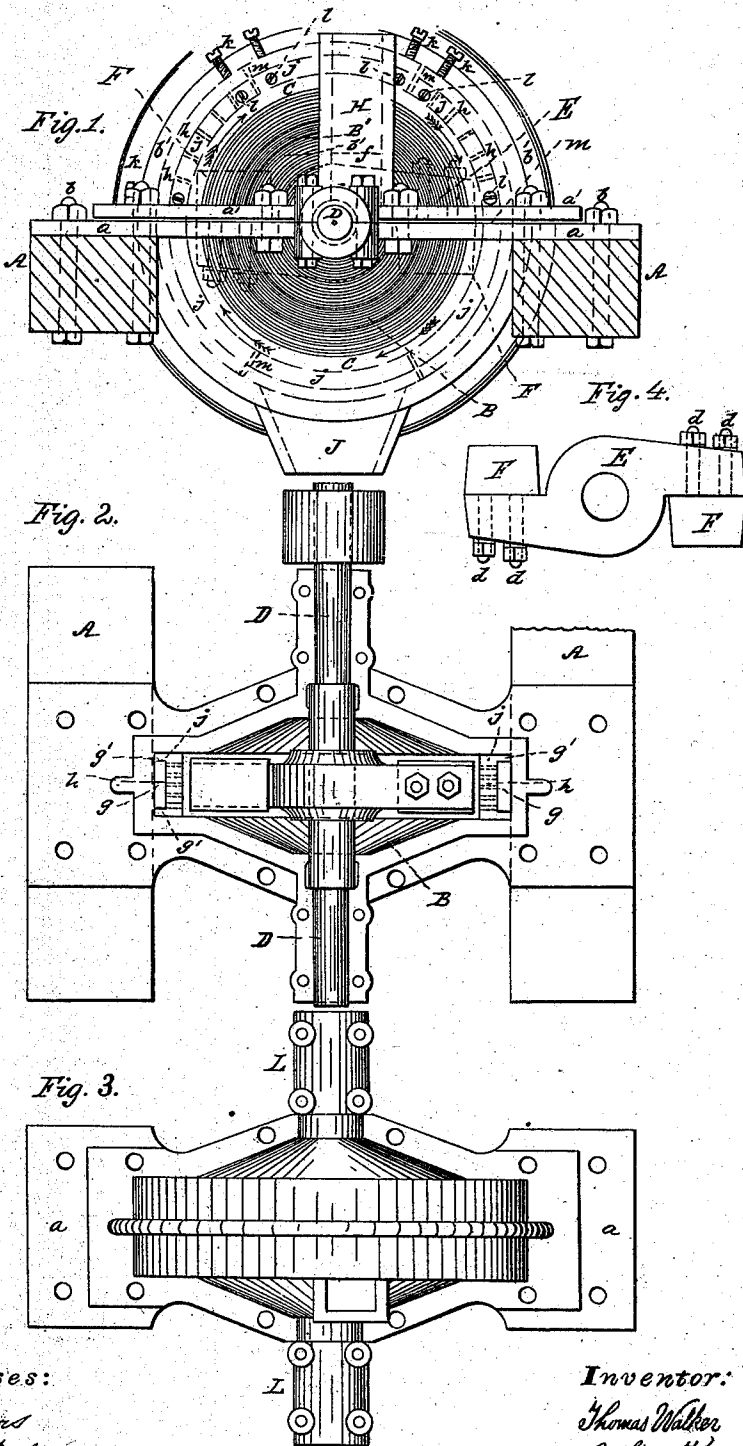

Witnesses:
J. S. Coles
Thomas J. Dewley

Inventor:
Thomas Walker
By his atty
Stephen Wash

UNITED STATES PATENT OFFICE

THOMAS WALKER, OF PHILADELPHIA, PENNSYLVANIA.

IMPROVEMENT IN QUARTZ-MILLS.

Specification forming part of Letters Patent No. **105,527**, dated July 19, 1870.

I, THOMAS WALKER, of the city of Philadelphia and State of Pennsylvania, have invented certain Improvements in Quartz-Mills, of which the following is a specification:

The nature of my invention consists of internal and external cylinders, which have an annular space between them, into which the pulverized quartz passes through suitable openings, and from which it escapes through a spout or chute, and hammers on a horizontal revolving shaft, by which the quartz or other material is disintegrated and reduced to a fine state, the hammers revolving at a high velocity, so as to separate and powder the quartz by percussion.

For the convenience in putting the mill together and taking it apart for repairs, and the adjustment and balancing of the hammers, the cylinders are bisected horizontally, the lower half of the outer cylinder being bolted to cross-timbers of a strong frame and the upper half confined to the lower half by means of bolts. The inner cylinder is composed of segments, to provide for convenience of chilling their inner surface and replacing of any worn-out or defective one, so as to prevent the loss of the whole cylinder. The upper segments are confined in the upper half of the outer cylinder by means of screws through one side of the cylinder, so that the whole upper half of the combined cylinders may be lifted from the lower half when necessary, and replaced without taking it apart. Instead of separating the whole upper half of the cylinder, but a portion of it may be made separate to carry out the design above stated.

Quartz-mills as usually constructed have to be made of immense strength, owing to the severe shocks caused by the striking of the stones against the cylinder when struck by the hammers, whereby the force is imparted throughout the whole cylinder. I overcome this difficulty in a great degree by inserting india-rubber or other elastic packing in the end joints of the segments of the internal cylinder, thereby breaking the force of the blows, and also breaking the communication of the force to the other parts of the cylinder.

To enable those skilled in the art to which my improvement appertains to make and use my invention, I will now give a detailed description thereof.

In the accompanying drawing, which makes

a part of this specification, Figure 1 is a side elevation of the mill. Fig. 2 is a plan of the same with the upper half of the cylinders B C removed. Fig. 3 is a top view of the upper half of the outer cylinder, B, the ends of the flange *a* of the lower half of the cylinder, and the journal-caps L L. Fig. 4 is a side view of the double arm E and hammers F F in connection therewith.

Like letters in all the figures indicate the same parts.

A A (seen in Figs. 1 and 2) are cross-timbers of a strong frame, upon which the flanges *a* of the lower half of the outer cylinder, B, rests, and is confined by means of bolts *b*. There are bolts *b'* which pass through the said flange and the flange *a'* of the upper half of the cylinder, which confine the two halves together.

The cylinder C, which forms the interior of the mill for the separation of the quartz, is placed within the cylinder B. D is a horizontal shaft, which is provided with a cross-arm, E, upon the ends of which the hammers F F are secured by means of bolts *d*. The said double arm and hammers F in connection with the same are represented in detail in Fig. 4. The said shaft D has a pulley, G, on one end, over which a belt passes that has communication with the motive power.

The upper half of the outer cylinder, B, is provided with a vertical hopper, H, for the reception of the quartz, which, in its descent, passes into the internal cylinder, C, the inner side of the hopper being open below the line *f* for that purpose. The outer periphery of cylinder C has an annular recess, *g*, into which the pulverized quartz is forced through suitable openings *h* by the force of the hammers F F, and upon which it passes into the chute J in its discharge from the mill. The recess *g* is formed by means of the flanges *g'*, which bear against the inside surfaces of the outer cylinder, B, whereby the cylinder C is readily held in position. These openings are at suitable distances apart around the cylinder, (more or less,) as may be found advisable. They are represented in Figs. 1 and 2.

The inner cylinder, C, is cast in segments *j*, as represented in Fig. 1, for convenience in chilling its internal surface and to provide for repairs or the replacing of worn-out or defective segments without the loss of the whole

cylinder, and so that gum or other elastic substance may be inserted to neutralize the concussion of the repeated blows of the quartz upon the cylinder, as hereinafter described.

The upper segments are tightened and held firmly in place by means of the screws *k*, which, pressing against the lower segments, hold them securely against the lower half of the outer cylinder. There are screws *l* which pass through one side of the upper half of the outer cylinder, B, and hold the segments tight against the other side of the same, to confine them securely in place, to provide for removing the upper half of the combined cylinders, when necessary, without taking them apart.

The journal-caps L L are made separate from the upper half of the outer cylinder, B, so that they may remain in place when said half of the cylinder is removed, thereby admitting of the lower part of the machine remaining undisturbed, and the revolving shaft D, carrying the hammers F F, accurately in position, to admit of the ready adjustment of the latter. I place pieces of india-rubber or other elastic material *m* between the ends of the segments *j* to break the shock caused by the striking of the quartz against the inner periphery of the cylinder C when struck by the hammers F F.

The operation is as follows: The quartz-rock or other material to be crushed or pulverized is placed in the hopper H, through which it falls into the inner cylinder, C, and is

struck by the hammers F as the shaft D revolves at a high velocity in the direction of the arrows, as seen in Fig. 1. The quartz, by the continual action of the hammers, is reduced to a fine or powdered state, and forced through the opening *h* of the cylinder into the annular space *g*, and falls into the chute J, and is discharged from the mill.

What I claim as my invention, and desire to secure by Letters Patent, is—

1. The combination of the bisected cylinder B, with perforated segments *j*, having spaces *g* and set-screws *l*, with cross-arms E, detachable hammers F F, and shaft D, when constructed and arranged as hereinbefore shown and described, for the purpose set forth.

2. In the cylinder B, the perforated segments *j*, in combination with the peripheral channel or space *g*, as and for the purpose set forth.

3. The elastic packing *m*, when arranged between the ends of the segments *j*, for breaking the shock caused by the striking of the quartz against the inner periphery of the cylinder C, substantially as described.

In testimony that the above is my invention I have hereunto set my hand and affixed my seal this 12th day of May, 1870.

THOS. WALKER. [L. S.]

Witnesses:

STEPHEN USTICK,

THOMAS J. BEWLEY.