

May 21, 1946.

W. B. KIRKPATRICK
APPARATUS FOR MAKING ICE

2,400,517

Filed Oct. 18, 1944

3 Sheets-Sheet 1

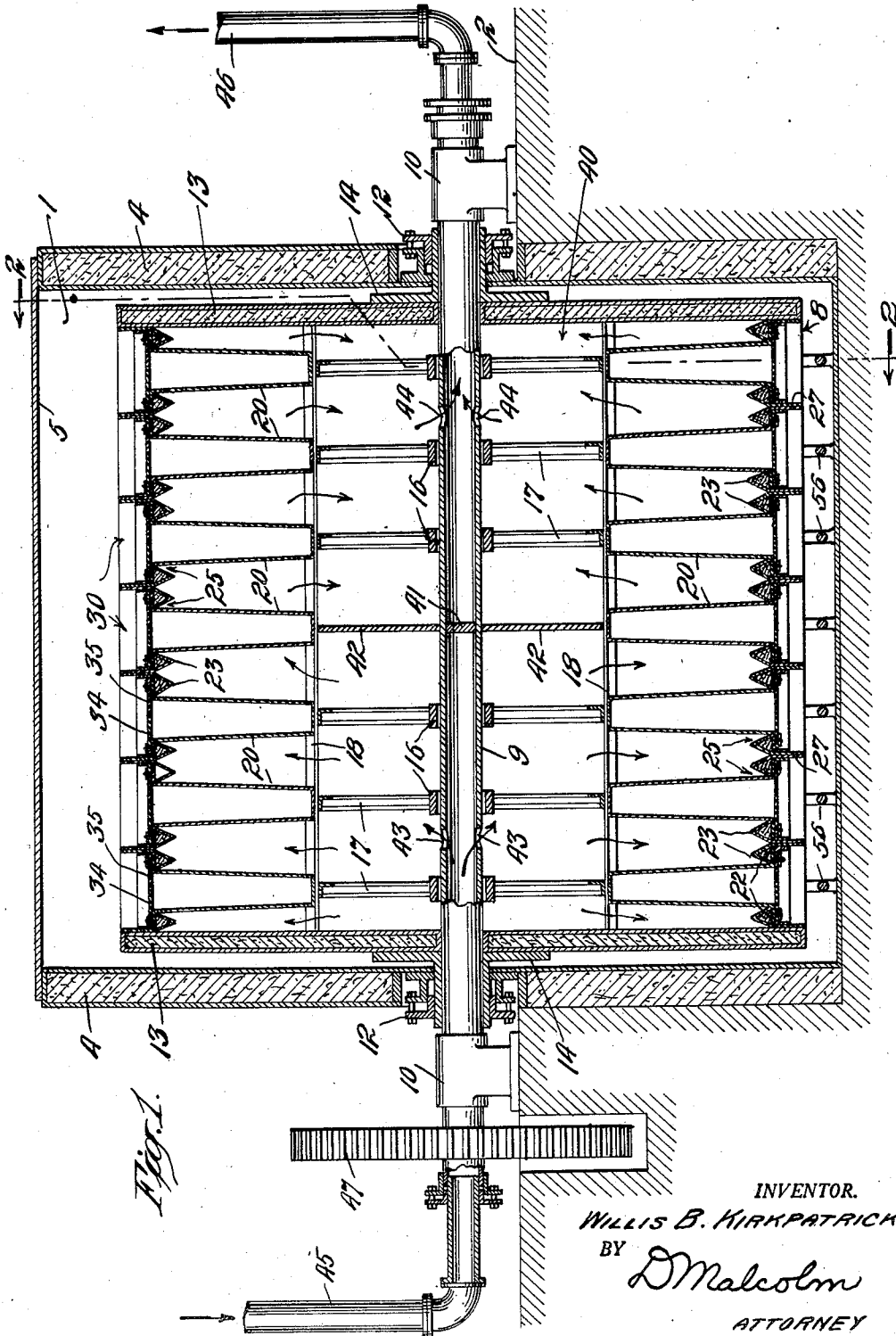

INVENTOR.
WILLIS B. KIRKPATRICK
BY *D. Malcolm*
ATTORNEY

May 21, 1946.

W. B. KIRKPATRICK

2,400,517

APPARATUS FOR MAKING ICE

Filed Oct. 18, 1944

3 Sheets-Sheet 2

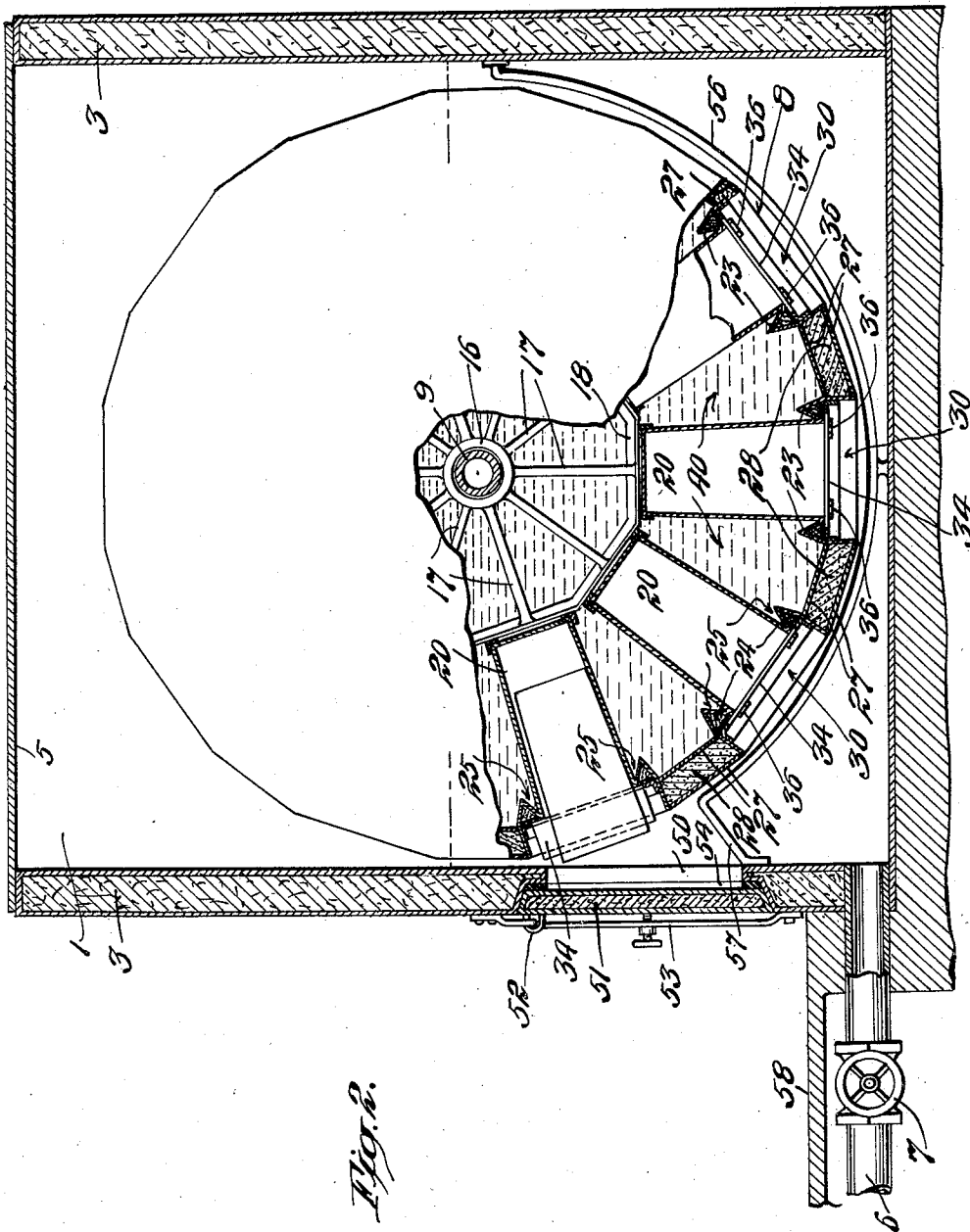

Fig. 2.

INVENTOR.
WILLIS B. KIRKPATRICK
BY *D. Malcolm*
ATTORNEY

May 21, 1946.

W. B. KIRKPATRICK

2,400,517

APPARATUS FOR MAKING ICE

Filed Oct. 18, 1944

3 Sheets-Sheet 3

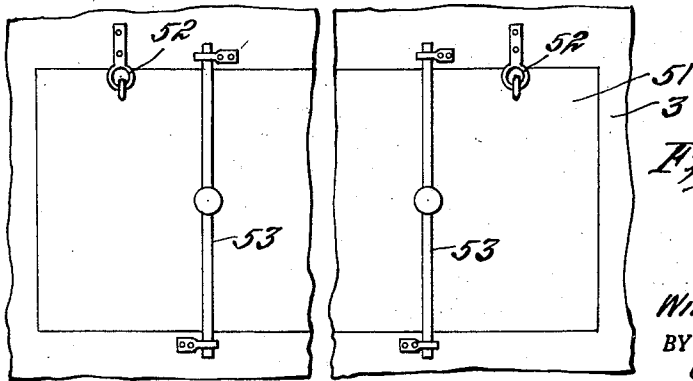
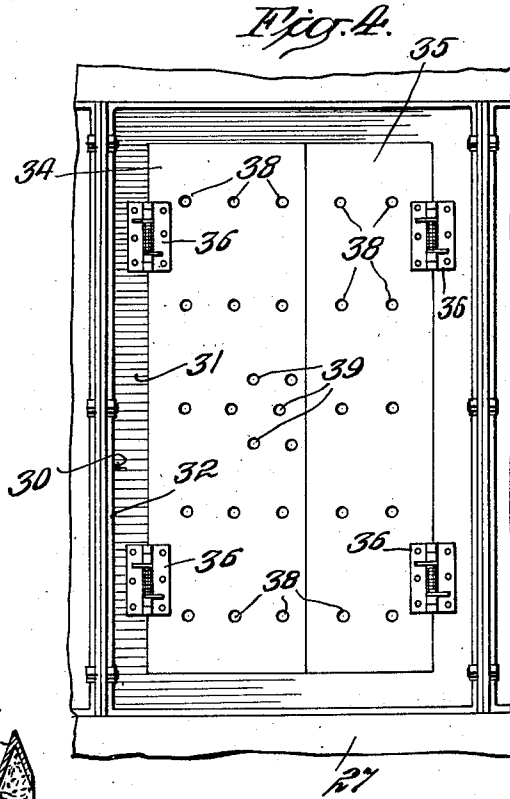
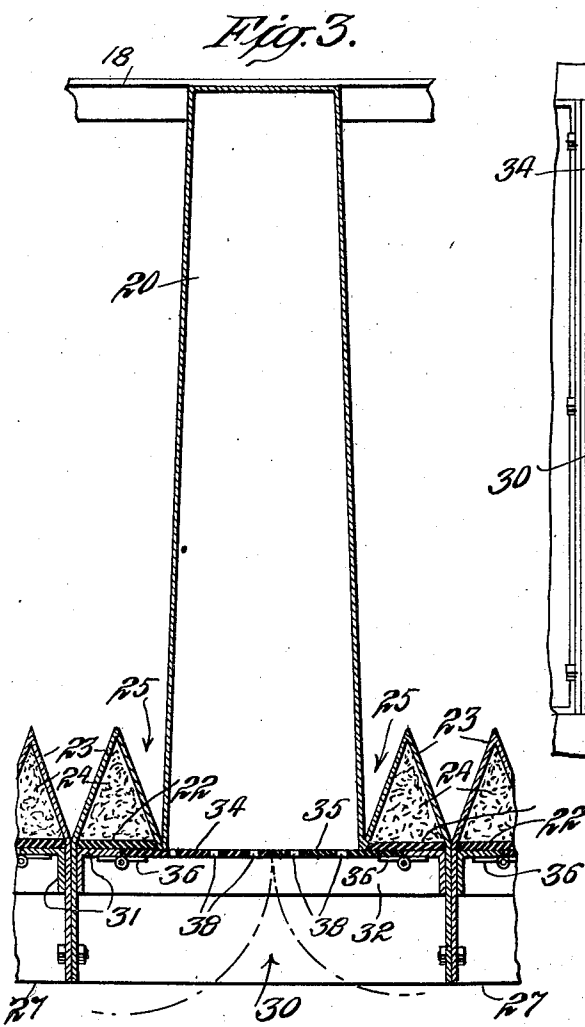

INVENTOR.
WILLIS B. KIRKPATRICK
BY *D. Malcolm*
ATTORNEY

UNITED STATES PATENT OFFICE

2,400,517

APPARATUS FOR MAKING ICE

Willis B. Kirkpatrick, Scarsdale, N. Y.

Application October 18, 1944, Serial No. 559,302

12 Claims. (Cl. 62—106)

This invention relates to the manufacture of ice, and this application is a continuation in part of my application Serial No. 499,914, filed August 25, 1943.

The principal object of the present invention is to provide a new and improved apparatus for making can ice economically and in large volume with a minimum of maintenance and supervision.

Another object of the invention is to provide an ice making machine of the above type which produces cakes of uniform size with flat square tops, without the use of special apparatus for measuring and supplying refrigerated water to the ice cans as in the past.

A further object is to manufacture clear can ice from raw water without the use of aeration or mechanical agitators such as are usually required to influence the crystallization of ice in a form clear enough to be merchantable.

Still another object is to provide an ice making machine of the above type which thaws the frozen cakes of ice from the cans and automatically discharges them onto a delivery chute or conveyor, thus eliminating the use of cranes and other expensive equipment which have heretofore been used for this purpose.

My improved apparatus comprises a tank containing the raw water or other liquid to be frozen, and a revoluble carrier partially immersed in the liquid in the tank and carrying a plurality of ice cans arranged radially like the spokes of a wheel with the tops of the cans at the outer periphery of the wheel. The interior of the revoluble carrier, comprising the space between the walls of the cans, is closed off from the tank and contains the refrigerating medium or brine. In the embodiment illustrated herein, the brine is conveyed to and from the interior of the carrier through a hollow revoluble shaft which supports the carrier.

According to a feature of the invention the tops or outer ends of the individual ice cans are closed by hinged plates or shutters containing a plurality of holes which permit water to flow into and out of the cans during the freezing operation. These shutters insure the formation of flat square tops on the ice cakes, as hereinafter described, and upon the completion of the freezing operation and subsequent thawing of the ice cakes the shutters open outwardly to discharge the cakes from the machine.

In operation, the tank is filled to the desired level with the raw water or other liquid to be frozen, and it will be evident to those skilled in

the art that it is much easier to fill a single tank of this sort than to separately fill a large number of stationary cans standing in a conventional brine tank. After the tank is charged, the refrigerant is circulated and the carrier is rotated. As the carrier continues to rotate, the liquid in the various cans freezes progressively inwardly from the walls thereof, leaving a gradually decreasing pool of liquid in each partially formed cake of ice, and the level of the liquid in the tank is low enough to cause these pools of liquid to flow out through the holes in the can shutters and slop over into the tank as each can reaches an inclined position above such liquid level. Since the liquid, in freezing, throws off occluded salts and other impurities, these impurities are continuously discharged from the cans as the gradually diminishing pools of water slop over into the tank during the continued rotation of the carrier.

The rotation of the carrier causes the continuous agitation of the liquid in the tank and in the cans, thus insuring the formation of clear ice without the use of special aeration or stirring devices which have heretofore been necessary to prevent the formation of objectionable white or cloudy cakes. Upon the completion of the freezing operation the temperature of the refrigerant circulating about the cans may be raised sufficiently to thaw the seal between the cans and the ice cakes, permitting the cakes to force open the shutters on the tops of the cans and to be discharged through a door in the side wall of the tank.

Although the novel features which are characteristic of this invention are set forth more in detail in the claims appended hereto, the nature and scope of the invention may be better understood by referring to the following description, taken in connection with the accompanying drawings forming a part thereof, in which a specific embodiment has been set forth for purposes of illustration.

In the drawings:

Fig. 1 is a vertical sectional view through an ice-making machine embodying the invention;

Fig. 2 is a transverse sectional view taken on line 2—2 of Fig. 1, with portions of the apparatus broken away to simplify the showing;

Fig. 3 is an enlarged vertical sectional view showing one of the ice cans with its hinged shutters;

Fig. 4 is a top plan view of one of the ice cans, showing the hinged shutters in the normal closed position; and

Fig. 5 is a fragmentary side view of the machine, showing the discharge door in closed position.

In the following description certain specific terms are used for convenience in referring to the various details of the invention. These terms, however, are to be interpreted as broadly as the state of the art will permit.

The apparatus illustrated herein by way of example comprises a tank 1 of rectangular cross-section set in the floor or foundation 2 of an ice plant, and having insulated side and end walls 3 and 4, respectively, and a suitable cover 5 for closing the top.

The raw water or other liquid to be frozen may be admitted through a suitable hose or pipe at the top of the tank; and the residue remaining after the freezing operation may be discharged through an outlet pipe 6 disposed at the bottom of the tank and provided with a control valve 7 as shown in Fig. 2.

The revoluble carrier 8 supporting the ice cans is mounted on a hollow shaft 9 which extends through the end walls 4 of tank 1 and is journaled in bearings 10 anchored in the floor 2 of the plant as shown in Fig. 1. Suitable glands or stuffing boxes 12 are provided to insure a tight seal between the tank and the revoluble shaft 9.

The carrier 8 comprises a pair of insulated end walls 13 secured to shaft 9 by flanged sleeves 14; and a plurality of skeleton wheels having hubs 16 surrounding shaft 9, spokes 17, and a polygonal rim 18 which is here shown to be in the form of a regular decagon with each of its ten sides supporting the base of an ice can 20.

In the embodiment illustrated, the ice cans 20 are one hundred in number, there being ten aligned cans in each file extending lengthwise of the machine as viewed in Fig. 1, and ten cans in each circumferential bank as viewed in the transverse section of Fig. 2, although it will be understood that the number and arrangement of cans may vary widely as desired. The side and end walls of the various ice cans are all tapered or flared slightly so as to be widest at the top or outer ends, in order to facilitate the discharge of the formed cakes of ice as hereinafter described.

The bases of the ice cans 20 are rigidly secured to the rims 18 of their respective supporting wheels, as by welding. The spaces between the outer rims of the adjacent cans, and between the end cans of each file and the adjacent end wall 13 of carrier 8, are sealed by water-tight rubber gaskets 22. Formed integral with the side walls of the cans 20 are metal extensions or plates 23 of triangular cross-section containing suitable insulating material 24, as best shown in Fig. 3. It will be noted that the angular plates 23 join the outer rims of the cans 20 at sharp angles, thus forming unobstructed areas 25 for the circulation of refrigerant about the outer perimeters of the various ice cans.

Metal blocks 27 containing suitable insulating material 28 are welded to the flat ends of the metal plates 23 so as to occupy the spaces between the outer rims of the adjacent cans 20 in a circumferential direction about the carrier, as shown in Fig. 2. These blocks 27 extend outwardly to the peripheral rim of the revoluble carrier 8, and it will be noted that, together with the flat ends of plates 23, they form rectangular open-ended compartments 30 entirely surrounding the outer end of each ice can 20. Secured within each such compartment 30 is a rectangular

frame 31, resembling a picture frame, having a marginal flange 32, the frame 31 resting on the gasket 22 which surrounds the outer rim of the can 20 while the flange 32 is secured to the walls of the adjacent insulating blocks 27.

A pair of flat, apertured closures or shutters 34 and 35 are hinged, as by spring-actuated hinges 36, to opposite parallel sides of each frame 31, the shutters 34 and 35 of each pair lying flush with and closing the outer rim of the adjacent ice can 20. The spring-actuated hinges 36 normally hold the shutters 34 and 35 in the closed position illustrated in the drawings (see Figs. 3 and 4), the shutters being adapted to open outwardly, as illustrated by the dotted lines in Fig. 3, to discharge the cakes of ice at the conclusion of the thawing operation, as hereinafter described. In practice I have made the frames 31 and shutters 34 and 35 of hard rubber, although it will be understood that they may be made of any other suitable material.

One of the shutters 34 of each pair is preferably somewhat wider than the other shutter 35 of the pair, thus bringing their line of contact away from the center of the can, which has proven advantageous in freezing the water in the cup or core of the ice cake. The shutters 34 and 35 contain a plurality of holes or perforations 38 which permit the water to flow into and out of the cans 20 through the closed shutters during the freezing operation. These holes 38 may be of any desired configuration and they may be spaced in any suitable manner, but I have found it advantageous to provide a plurality of closely spaced holes (such as the holes 39 in Fig. 4) grouped about that region of the wider shutter 34 which overlies the center of the can where the gradually diminishing cup of water is formed during the freezing operation.

It will be seen from the foregoing that the interior of the revoluble carrier 8, comprising the space 40 between the bottom, side and end walls of the ice cans 20, is completely closed off from the tank 1 by the said walls of the cans and by the plates 23 and blocks 27 which seal the spaces between the outer rims of the various cans, this space 40 being the enclosure which contains the refrigerating medium or brine as indicated by the light "dash-lines" in Fig. 2. To insure proper circulation of refrigerant through the enclosure 40 the hollow shaft 9 is partitioned at the center by a suitable plug 41, while the enclosure 40 itself is partly closed off by a central partition or baffle plate 42, and the hollow shaft 9 is provided with suitable openings 43 and 44, respectively, on opposite sides of the partition 42, as shown in Fig. 1. The refrigerant is circulated continuously, entering shaft 9 through pipe 45, flooding the portion of enclosure 40 to the left of partition 42 as viewed in Fig. 1, and passing over the periphery of partition 42 into the right-hand portion of enclosure 40, whence the refrigerant passes through openings 44 in shaft 9 to the return pipe 46 of the circulatory system. During the freezing operation the enclosure 40 is at all times filled with refrigerant which completely fills the spaces between the ice cans as shown in Fig. 2.

In operation, the tank 1 is filled to the desired level with the raw water to be frozen, and in Fig. 2 the tank is shown about half filled, or what corresponds to the "3-o'clock" position on a clock dial. After the tank is charged, the refrigerant is circulated in the manner described above, and the carrier 8 is rotated as by means of a driving gear 47 which is keyed to shaft 9 as shown in

Fig. 1. Rotation may be in either a clockwise or counter-clockwise direction as viewed in Fig. 2. As the carrier continues to rotate, the liquid in the various cans 20 freezes progressively inwardly from the walls thereof, leaving a gradually decreasing pool of liquid in each partially formed cake of ice. The level of the liquid in the tank 1 is low enough to cause these pools of liquid to flow out through the perforated shutters 34-35 on the cans and slop over into the tank as each can reaches an inclined position above such liquid level. The liquid, in freezing, throws over occluded salts and other impurities, so that these impurities are continuously discharged from the cans as the gradually diminishing pools of water slop over into the tank during the continued rotation of the carrier. Even in the final stages of freezing the pools of water in the upper central portions of the ice cakes are readily discharged through the grouped holes 39 in shutters 34.

The rotation of the carrier 8 causes the continuous agitation of the water in tank 1 and in the cans 20, which results in the formation of clear ice without the use of aerating or stirring devices. Furthermore, the rotation of the carrier also insures adequate agitation of the refrigerant between the walls of the ice cans as the refrigerant continues to circulate in the manner described above. The operation continues in the manner described until the completion of the freezing operation, at which time the cakes of ice are all uniformly frozen and are separate from each other due to the fact that the insulated areas 24 and 28 between the upper perimeters of adjacent ice cans prevent the formation of connecting sheets of ice and also prevent the formation of ice about the hinges 36 of shutters 34-35. At the same time, the unobstructed areas 25 surrounding said insulated areas 24 insure the proper freezing of the contents of the cans up to the top. The shutters 34-35, being closed during the freezing operation, insure the formation of flat square tops on the ice cakes, greatly improving their appearance and facilitating subsequent stacking and handling. Upon the completion of the freezing operation the temperature of the refrigerant circulating throughout the enclosure 40 may be raised slightly to thaw the seal between the cans and the ice cakes, permitting the cakes to be dislodged from the cans and discharged from the machine in a manner which will now be described.

For discharging the formed cakes of ice from the cans, I provide an elongated rectangular opening 50 in one of the side walls 3 of tank 1. This opening is slightly longer than the file of ten ice cans, and it is adapted to be closed by a door 51 which is secured to the side wall 3 by suitable hasps 52 and opens upwardly as will be evident from Figs. 2 and 5. The door 51 is adapted to be locked in closed position by swivel latches 53 and is made water-tight by a rubber or other suitable packing 54.

When the temperature of the refrigerant is raised to thaw the seal between the cans and the ice cakes it will be evident that all of the cakes will be thawed simultaneously. In order to prevent the cakes from being dislodged prematurely before they reach the open door 51, a guard comprising a plurality of arcuate metal rods 56 is secured within the tank about the lower peripheral portion of the rotary carrier 8, the said rods 56 terminating in inclines 57 for guiding the freed cakes of ice through the open door 51. Assuming that the carrier 8 rotates in

a clockwise direction as viewed in Fig. 2, the thawed cakes of ice will emerge from the cans 20 and force the hinged shutters 34-35 outwardly when said cakes reach an inclined position slightly below the "3-o'clock" position mentioned above. The descent of the partly protruding cakes, however, will be arrested by the arcuate rods 56, and, as the carrier 8 continues to rotate, said cakes will be carried around in contact with the rods 56 until they reach the inclines 57 which guide the cakes out through the opening 50 of door 51 onto the platform 58.

When it is desired to discharge the formed cakes of ice from the cans 20, all ten cans of one file or row are discharged at one time. At the completion of the freezing operation, the water remaining in tank 1 is drawn off through outlet pipe 6, after which the door 51 is opened. As previously explained, the temperature of the refrigerant circulating through the system is raised sufficiently to thaw the seal between the cans and the ice cakes, and the cakes, being tapered slightly to facilitate dislodgment, are now ready to be discharged. As the various files of cans 20 arrive at the discharging position adjacent the open door 51, the cakes of ice slide down the inclines 57 onto the platform 58 as described above.

One important advantage of the foregoing apparatus is that it effects a considerable saving in floor space; the usual system of stationary freezing tanks requires approximately 37 square feet of floor space per ton of ice-making capacity, whereas my improved machine requires no more than 20 square feet of floor space per ton of ice-making capacity.

My apparatus also makes it possible to reduce the freezing time by nearly 40%. With ordinary freezing tanks such as are commonly employed in the industry, from 40 to 45 hours are usually required to freeze a cake of ice, whereas my apparatus can freeze a cake of ice in about 24 hours. Furthermore, a substantial saving of time is effected in thawing the ice off since in my machine containing, for example, one hundred cans, the ice can be thawed off in the time previously required to thaw off a single row of say 20 cans, from a stationary brine tank. My machine also reduces the thawing off or harvesting period from a more or less continuous daily operation to a few minutes time, resulting in a saving of labor and a very greatly increased efficiency in the freezing surface employed. Time is also saved, of course, over the present freezing system in the time it takes to transport the cans to the dip tank, dump them, refill the cans with water and return them to the freezing tank.

As explained above, my ice-making apparatus requires no brine agitation, since this is provided for by the rotation of the revoluble carrier which thus eliminates the use of mechanical agitators such as are required in other freezing systems. My apparatus, furthermore, does not require agitation of the water in the cans to produce clear cakes of ice, as this agitation is also provided by the rotation of the carrier. This not only does away with air compressors, but also with the dehydration of the air. A considerable amount of equipment is required in connection with the furnishing of dehydrated air to each can in stationary tank freezing systems.

The apparatus described above also eliminates the necessity for raising the cans out of freezing tanks, and it likewise eliminates the necessity of transporting the ice cans by means of hoists

and traveling cranes to dip-tanks. Furthermore, it is not necessary in my apparatus to thaw the ice out of the cans by means of heated water as is the usual practice in ordinary freezing tanks, since thawing is accomplished in my apparatus by raising the temperature of the refrigerant in the rotating carrier by reducing the temperature of the incoming water, as by means of heat exchangers, to only 38° to 40° F. The internal temperature of the cakes of ice, which is usually about 17° F. with 15° F. brine, is raised to the melting point or nearly so if exposed for a prolonged period to, say, 65° F. water in a dip tank; whereas with my machine the ice is thawed from the side and bottom surfaces of the cans in approximately one minute, which results in maintaining the internal temperature of the ice at or about 17° F. which temperature refrigerates the entire cake and keeps it from melting for a long period of time.

My invention also eliminates the necessity for employing special dumping devices to dump the ice out of the cans, since the ice cakes will readily leave the cans when they reach the dumping position. Of course, all the ice cakes will be thawed off at the same time, but the arcuate guard previously described controls the discharge of the ice cakes and enables each row of cakes to be discharged when the correct dumping position is reached.

In ordinary stationary freezing tanks it is necessary to suck the core-water out while the cakes are about half frozen, and then refill the cores with fresh water. This is unnecessary in my machine since the cores will be "scoured" at two points of the circle during the rotation of the carrier as described above. An additional advantage of my apparatus is that it eliminates the necessity for handling covers for the individual ice cans as is required in previous ice-making apparatus.

It will be evident to those skilled in the art that various changes may be made in the details of construction and method of operation described herein without departing from the scope and spirit of the invention as defined in the appended claims.

The invention claimed is:

1. Apparatus for making ice comprising a tank adapted to contain a liquid to be frozen, a revoluble carrier including an ice can mounted in said tank with its outer end positioned to admit a body of said liquid from said tank and having bottom and side walls extending into and forming a permanent part of a compartment for a refrigerant, and means on the outer end of said can controlling the passage of liquid, alternately, into and out of said can and for shaping the top of the ice formed therein during the freezing operation.

2. Apparatus for making ice comprising a tank adapted to contain a liquid to be frozen, a revoluble carrier including an ice can mounted in said tank with its outer end positioned to admit a body of said liquid from said tank and having bottom and side walls extending into and forming a permanent part of a compartment for a refrigerant, and an apertured closure for the outer end of said can permitting the passage of liquid therethrough and limiting the level of the ice formed in said can.

3. Apparatus for making ice comprising a tank adapted to contain a liquid to be frozen, a revoluble carrier including an ice can mounted in said tank with its outer end positioned to admit a body

of said liquid from said tank and having bottom and side walls extending into and forming a permanent part of a compartment for a refrigerant, and a flat, apertured closure for the outer end of said can permitting the passage of liquid therethrough and limiting the level of the ice formed in said can.

4. Apparatus for making ice comprising a tank adapted to contain a liquid to be frozen, a revoluble carrier including a plurality of ice cans partly immersed in the liquid in said tank with the outer ends of said cans positioned to admit a body of said liquid from said tank and the bottom and side walls of said cans extending into and forming a permanent part of a chamber for the circulation of a refrigerant about said cans, shutters mounted on said carrier in position to close the outer ends of the respective cans and adapted to open to release the ice from said cans, said shutters containing apertures for the passage of liquid between said cans and said tank, means for rotating said carrier, and means for circulating a refrigerant through said refrigerant chamber.

5. Apparatus for making ice comprising a tank adapted to contain a liquid to be frozen, a revoluble carrier including a plurality of ice cans partly immersed in the liquid in said tank with the outer ends of said cans positioned to admit a body of said liquid from said tank and the bottom and side walls of said cans extending into and forming a permanent part of a chamber for the circulation of a refrigerant about said cans, pairs of cooperating shutters mounted on said carrier and adapted to close the outer ends of the respective cans and to open outwardly to release the ice from said cans, said shutters containing apertures for the passage of liquid between said cans and said tank, means for rotating said carrier, and means for circulating a refrigerant through said refrigerant chamber.

6. Apparatus for making ice comprising a tank adapted to contain a liquid to be frozen, a revoluble carrier including a plurality of radially-disposed ice cans partly immersed in the liquid in said tank with the outer ends of said cans positioned to admit a body of said liquid from said tank and the bottom and side walls of said cans extending into and forming a permanent part of a chamber for the circulation of a refrigerant about said cans, means on the outer surface of said carrier between adjacent cans forming individual open-ended compartments surrounding the outer ends of said cans, pairs of cooperating shutters mounted on opposite sides of said compartments and adapted to lie flat against the outer ends of the respective cans and to open outwardly to release the ice from said cans, said shutters containing a plurality of apertures for the passage of liquid between said cans and said tank, means for rotating said carrier, and means for circulating a refrigerant through said refrigerant chamber.

7. Apparatus for making ice comprising a tank adapted to contain a liquid to be frozen, a revoluble carrier including a plurality of radially-disposed ice cans partly immersed in the liquid in said tank with the outer ends of said cans positioned to admit a body of said liquid from said tank and the bottom and side walls of said cans extending into and forming a permanent part of a chamber for the circulation of a refrigerant about said cans, means on the outer surface of said carrier between adjacent cans forming individual open-ended compartments surrounding

the outer ends of said cans, pairs of cooperating spring-actuated shutters hinged on opposite sides of said compartments and adapted to lie flat against the outer ends of the respective cans and to open outwardly to release the ice from said cans, one shutter of each pair being wider than the other shutter of the pair to offset their line of contact from the center line of the can, said shutters containing a plurality of apertures for the passage of liquid between said cans and said tank and the wider shutter of each pair containing a group of such apertures in the region overlying the center of the can, means for rotating said carrier, and means for circulating a refrigerant through said refrigerant chamber.

8. Apparatus for making ice comprising a tank adapted to contain a liquid to be frozen, a revoluble carrier including a plurality of radially-disposed ice cans partly immersed in the liquid in said tank with the outer ends of said cans positioned to admit a body of said liquid from said tank and the bottom and side walls of said cans extending into and forming a permanent part of a common chamber for the circulation of a refrigerant about said cans, walls containing insulating material on the outer surface of said carrier between adjacent cans forming individual open-ended rectangular compartments surrounding the outer ends of said cans, pairs of cooperating spring-actuated shutters hinged on opposite sides of said compartments and adapted to lie flat against the outer ends of the respective cans and to open outwardly to release the ice from said cans, one shutter of each pair being wider than the other shutter of the pair to offset their line of contact from the center line of the can, said shutters containing a plurality of apertures for the passage of liquid between said cans and said tank and the wider shutter of each pair containing a group of such apertures in the region overlying the center of the can, means for rotating said carrier, and means for circulating a refrigerant through said refrigerant chamber.

9. Apparatus for making ice comprising a tank adapted to contain a liquid to be frozen, a revoluble carrier including a plurality of rows of radially-disposed ice cans partly immersed in the liquid in said tank with the outer ends of said cans positioned to admit a body of said liquid from said tank and the bottom and side walls of said cans extending into and forming a permanent part of a common chamber for the circulation of a refrigerant about said cans, insulation in said chamber in the space between the outer peripheries of said cans spaced from the walls of the cans to prevent the formation of connecting sheets of ice between adjacent cans while permitting access of the refrigerant to all parts of the can walls, walls containing insulating material on the outer surface of said carrier between adjacent cans forming individual open-ended rectangular compartments surrounding the outer ends of said cans, pairs of cooperating spring-actuated shutters hinged on opposite sides of said compartments and adapted to lie flat against the outer ends of the respective cans and to open outwardly to release the ice from said cans, one shutter of each pair being wider than the other shutter of the pair to offset their line of contact from the center line of the can, said shutters containing a

plurality of apertures for the passage of liquid between said cans and said tank and the wider shutter of each pair containing a group of such apertures in the region overlying the center of the can, means for rotating said carrier, and means for circulating a refrigerant through said refrigerant chamber.

10. Apparatus for making ice comprising a tank adapted to contain a liquid to be frozen, a revoluble carrier including a plurality of rows of radially-disposed ice cans partly immersed in the liquid in said tank with the outer ends of said cans positioned to admit a body of said liquid from said tank and the bottom and side walls of said cans extending into and forming a permanent part of a common chamber for the circulation of a refrigerant about said cans, insulation in said chamber in the spaces between the outer peripheries of said cans spaced from the walls of the cans to prevent the formation of connecting sheets of ice between adjacent cans while permitting access of the refrigerant to all parts of the can walls, walls containing insulating material on the outer surface of said carrier between adjacent cans forming individual open-ended rectangular compartments surrounding the outer ends of said cans, pairs of cooperating spring-actuated shutters hinged on opposite sides of said compartments and adapted to lie flat against the outer ends of the respective cans and to open outwardly to release the ice from said cans, one shutter of each pair being wider than the other shutter of the pair to offset their line of contact from the center line of the can, said shutters containing a plurality of apertures for the passage of liquid between said cans and said tank and the wider shutter of each pair containing a group of such apertures in the region overlying the center of the can, a rotatable shaft supporting said carrier and containing a passage communicating with said refrigerant chamber for the circulation of the refrigerant therein, means for rotating said shaft, and means for circulating a refrigerant through said passage and said chamber.

11. Apparatus for making ice comprising a can having bottom and side walls and having its outer end open to admit the liquid to be frozen, an enlarged open-ended compartment surrounding the outer end of said can, and a pair of cooperating shutters mounted on opposite sides of said compartment and adapted to lie flat against the outer end of said can and to open outwardly to release the ice from said can, said shutters containing apertures for the passage of liquid.

12. Apparatus for making ice comprising a can having bottom and side walls and having its outer end open to admit the liquid to be frozen, an enlarged open-ended compartment surrounding the outer end of said can, and a pair of cooperating spring-actuated shutters hinged on opposite sides of said compartment and adapted to lie flat against the outer end of said can and to open outwardly to release the ice from said can, one shutter of said pair being wider than the other to offset their line of contact from the center line of the can, said shutters containing a plurality of apertures for the passage of liquid, and the wider shutter of the pair containing a group of such apertures overlying the center of the can.

WILLIS B. KIRKPATRICK.