

May 16, 1961

P. DORNIER

2,984,699

DEVICE FOR INSPECTING MOVING LENGTHS OF FABRIC

Filed Feb. 14, 1957

*Fig. 1.*

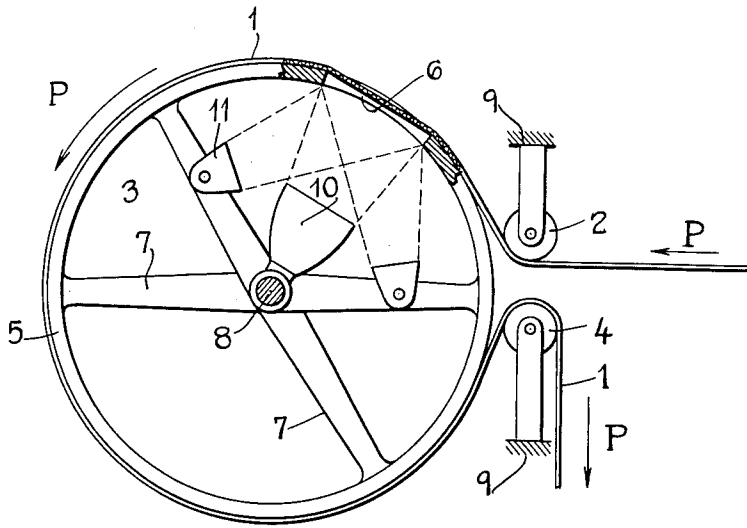

*Fig. 2.*

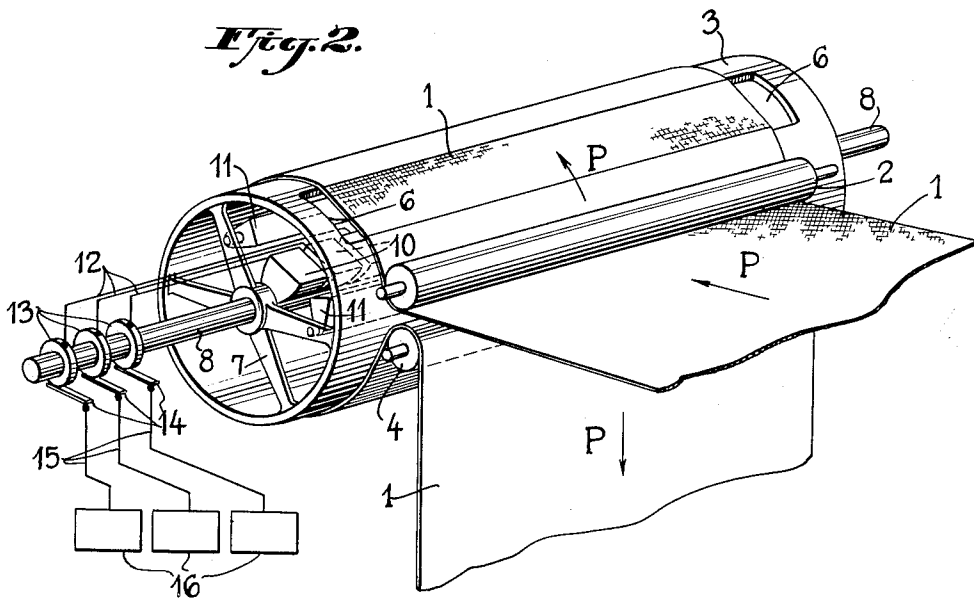

INVENTOR.  
*PETER DORNIER.*  
BY *H. A. Mayr.*  
ATTORNEY.

1

2,984,699

**DEVICE FOR INSPECTING MOVING LENGTHS OF FABRIC**

Peter Dornier, Lindau, Germany, assignor to Lindauer Dornier G.m.b.H., Lindau am Bodensee, Germany, a firm of Germany

Filed Feb. 14, 1957, Ser. No. 640,164

Claims priority, application Germany Feb. 27, 1956

5 Claims. (Cl. 178—7.1)

The present invention relates to a device for inspecting moving lengths of fabric.

In the device according to the invention an image of the fabric is received by a television apparatus which moves at the same speed as the fabric and transmits the image to a stationary screen.

An object of the invention is to provide an apparatus by means of which dislocation of weft threads in fabrics which move at speeds greater than 40 meters per minute can be conveniently observed. Up to that speed the human eye can discover distortions in the fabric. In modern textile plants the fabric moves at speeds between 60 meters per minute and 150 meters per minute so that observation of distortion or irregularities in the fabric is difficult or impossible. If the speed of movement of the fabric is reduced, the utilization coefficient of the textile machinery is too much reduced.

Stroboscopically acting devices have been proposed. These devices operate satisfactorily only at much greater speeds of the moving object than are customary in textile plants. At lower speeds stroboscopically acting devices do not produce quiet pictures.

It has also been proposed to transport television sending apparatus along the moving fabric and to transmit the received image to one or a plurality of stationary screens. In this case at least two or three rows of television senders must be alternately connected with the viewing screens. These arrangements are expensive and complicated.

The arrangement of the television apparatus according to the invention is considerably simpler than the conventional devices referred to in the paragraph next above. In the system according to the invention wide lengths of fabric are conducted around a hollow cylindrical or almost cylindrical rotating element which is entirely or partly transparent. The circumferential speed of the body is the same as that of the fabric. The cylindrical element which may be called a drum or a reel has either a shell which is transparent all around or which has an opening or a window portion made of transparent material whereby the location and width of the window corresponds to the range covered by the television apparatus. One or a plurality of television sending apparatuses are located within and are connected with the drum, to rotate therewith, the vision of the television apparatus being directed substantially radially of the drum towards the window. Illuminating means are provided inside the drum and connected thereto for rotation therewith. The illuminating means cast a light beam onto the transparent portion of the drum.

In order to facilitate discovery of dislocations of weft threads in the fabric lines are preferably provided on the transparent portion of the cylinder which lines are parallel to the rotation axis of the cylinder.

The cylinder or drum is either rotated by the fabric or by drive means, as an electric motor or the like.

The pulses produced by the television viewing and sending apparatus are transmitted through brushes to

2

one or more receiving apparatuses. The number of sending apparatuses preferably corresponds to the number of receiving apparatus which are arranged so close to each other that a substantially coherent image of the fabric is produced.

The number of television sending and receiving apparatus to be used in the device according to the invention depends on the range which can be covered by the individual apparatus and on the width of the fabric to be inspected. It is not always necessary to transmit an image of the whole fabric in order to discover dislocations of the weft threads.

If the diameter of the drum is about one meter and the speed of advance of the fabric is 90 meters per minute the period during which the fabric can be viewed amounts to two seconds per revolution of the drum which time is ample to discover faults in the fabric. A distortion of the fabric usually extends over a greater area than the surface of the drum so that it will be seen not only during one revolution but also at the subsequent revolution of the drum.

The novel features which are considered characteristic of the invention are set forth with particularity in the appended claims. The invention itself, however, and additional objects and advantages thereof will best be understood from the following description of an embodiment thereof when read in connection with the accompanying drawing in which:

Fig. 1 is a schematic end view of an arrangement according to the invention;

Fig. 2 is a perspective schematic view of the arrangement according to Fig. 1.

Like parts are designated by like numerals in the two figures of the drawing.

Numeral 1 designates a fabric moving in the direction of the arrows P first around a guide roller 2, thereupon around a cylindrical element 3, and then around a guide roller 4. The element 3 includes a shell 5 made of opaque material and having a transparent portion 6 which, in the illustrated embodiment, is a rectangular opening. The shell 5 is connected with a shaft 8 by a plurality of spokes 7. The shaft 8 rotates in bearings, not shown, provided on a frame 9 which also supports the rollers 2 and 4.

A plurality of television viewing and sending apparatuses 10 are mounted on the shaft 8 to rotate therewith. Illuminating devices 11 are mounted on the spokes 7 and rotate with the element 3. The television sending apparatuses 10 are so located that their direction of vision is substantially radial and towards the transparent portion 6. The illuminating devices 11 direct light beams onto the transparent portion 6.

The television apparatuses 10 are connected by means of conduits 12 with slip rings 13 mounted on the shaft 8. Brushes 14 engage the slip rings 13 and transmit electric pulses through conduits 15 to television receiving apparatuses including stationary screens 16.

I claim:

1. A device for instantaneously inspecting moving lengths of fabric including a hollow substantially cylindrical axially unmovable rotatable member having a circumferential wall around which the fabric is laid and which rotates at a circumferential speed equal to the speed of movement of the fabric, at least a portion of said wall being transparent, a conventional television sending apparatus located within and rigidly connected to said member to rotate therewith and having a direction of vision directed towards said transparent portion, and a conventional stationary television receiving and viewing apparatus electrically connected to said sending apparatus for instantaneously viewing the fabric as it travels with the range of vision of said sending appa-

3

ratus whereby transverse portions of the fabric can be viewed as a stationary image during a maximal period of time corresponding substantially to a full revolution of said cylindrical member.

2. A device as defined in claim 1 including illuminating means located within and rigidly connected to said member to rotate therewith and directing light onto said transparent portion.

3. A device as defined in claim 1 in which said member has a shell made of transparent material.

4. A device as defined in claim 1 in which said transparent portion is formed by an opening in said member.

4

5. A device according to claim 4 including a transparent closure for said opening.

References Cited in the file of this patent

UNITED STATES PATENTS

2,435,250	Tandler	Feb. 3, 1948
2,561,197	Goldsmith	July 17, 1951
2,573,350	Miller	Oct. 30, 1951
2,822,720	Douglas	Feb. 11, 1958

FOREIGN PATENTS

614,317	Great Britain	Dec. 14, 1948
---------	---------------	---------------

5

10